

Combat®

UHA-Series Tubular Unit Heaters (Standard Range) Installation, Operation & Service Manual

Models UHA[T][M][X][S]
150, 175, 200, 225
250, 300, 350, 400



FOR YOUR SAFETY

If you smell gas:

1. Open windows.
2. **DO NOT** try to light any appliance.
3. **DO NOT** use electrical switches.
4. **DO NOT** use any telephone in your building.
5. Extinguish any open flame.
6. Leave the building.
7. Immediately call your local gas supplier after leaving the building. Follow the gas supplier's instructions.
8. If you cannot reach your gas supplier, call the Fire Department.

⚠ WARNING



Fire Hazard

Keep all flammable objects, liquids and vapors the minimum required clearances to combustibles away from heater.

Some objects will catch fire or explode when placed close to heater.

Failure to follow these instructions can result in death, injury or property damage.

⚠ WARNING

Improper installation, adjustment, alteration, service or maintenance can result in death, injury or property damage. Read the Installation, Operation and Service Manual thoroughly before installing or servicing this equipment.

Installation must be done by a contractor qualified in the installation and service of gas-fired heating equipment or your gas supplier.

Installer

Please take the time to read and understand these instructions prior to any installation. Installer must give a copy of this manual to the owner.

Owner

Keep this manual in a safe place in order to provide your service technician with necessary information.



C US
Energy Verified

Roberts-Gordon LLC
1250 William Street
P.O. Box 44
Buffalo, New York 14240-0044
Telephone: +1.716.852.4400
Fax: +1.716.852.0854
Toll Free: 800.828.7450

www.robertsgordon.com
www.rg-inc.com

Combat®

UHA-Series Aérothermes tubulaire (Gamme standard)

Manuel d'installation, d'opération, et de service

Modèles UHA[T][M][X][S]

150, 175, 200, 225

250, 300, 350, 400



POUR VOTRE SECURITE

Si vous sentez une odeur de gaz:

1. Ouvrir les fenêtres.
2. N'essayer pas d'allumer un appareil.
3. N'utiliser pas d'interrupteurs électriques.
4. N'utiliser pas de téléphone dans votre bâtiment.
5. Eteindre flamme nue.
6. Quitter le bâtiment.
7. Après avoir quitté le bâtiment, appelez immédiatement votre fournisseur local de gaz.
Suivre les instructions du fournisseur de gaz.
8. Si vous ne pouvez pas joindre votre fournisseur de gaz, appeler le service d'incendie.

⚠ AVERTISSEMENT



Risque d'incendie

Garder tous les objets, liquides ou vapeurs inflammables à la distance minimale de l'unité de chauffage requise avec les matériaux combustibles.

Certains objets prendront feu ou exploseront s'ils sont placés à proximité de l'unité de chauffage.

Le non respect de ces instructions peut entraîner la mort, des blessures corporelles ou des dommages matériels.

⚠ ATTENTION

L'installation, l'ajustement, l'altération, le démarrage ou l'entretien inadéquat peuvent causer la mort, des blessures ou des dégâts matériels. Lire entièrement le manuel d'installation, d'opération et d'entretien avant l'installation ou l'entretien de cet équipement.

L'installation doit être effectuée par un installateur éprouvé/contractant qualifié dans l'installation et la maintenance du système de chauffage par infrarouge activé au gaz.

Installateur

Prenez le temps de lire et comprendre ces instructions avant toute installation.

L'installateur doit remettre au propriétaire un exemplaire de ce manuel.

Propriétaire

Gardez ce manuel dans un endroit sûr pour fournir des informations au réparateur en cas de besoin.



C US
Energy Verified

Roberts-Gordon LLC

1250 William Street

P.O. Box 44

Buffalo, New York 14240-0044

Téléphone: +1.716.852.4400

Fax: +1.716.852.0854

Numéro sans frais: 800.828.7450

www.robertsgordon.com

www.rg-inc.com

TABLE OF CONTENTS

SECTION 1: Heater Safety	1	SECTION 12: User Instructions	35
1.1 Manpower Requirements	1	12.1 Heater Operation	35
1.2 Safety Labels and Their Placement.....	1	12.2 Lighting Instructions	35
1.3 California Proposition 65	1	12.3 Simple Troubleshooting	35
SECTION 2: Installer Responsibility	4	SECTION 13: Servicing	37
2.1 Wall Tag	4	13.1 Servicing Instructions	37
2.2 Corrosive Chemicals	4	13.2 Burner Maintenance	37
2.3 National Standards and Applicable Codes.....	4	13.3 Fan/Motor Assembly Maintenance	37
SECTION 3: Critical Considerations	5	13.4 Heat Exchanger Maintenance	38
3.1 Basic Information	5	13.5 Gas Valve Maintenance.....	38
3.2 Manufactured Units.....	5	13.6 Flue Blower	38
3.3 Location and Suspension	5	13.7 Venting and Air Intake Pipe	38
3.4 Minimum Required Installation Clearances	5	SECTION 14: Troubleshooting	41
3.5 Ventilation	5	SECTION 15: Replacement Parts	46
3.6 Gas Supply	5	15.1 Gas Valve	46
3.7 Electrical Supply	5	15.9 Ignition Control	53
3.8 Vent.....	5	15.10 Axial Fan/Guard/Motor Assembly.....	53
SECTION 4: Clearances TO combustibles	6	15.11 Limit Switches.....	54
4.1 Required Clearances to Combustibles.....	6	SECTION 16: Specifications	55
4.2 Clearances to Combustibles	6	SECTION 17: The ROBERTS GORDON® UHA-Series	
SECTION 5: National Standards and Applicable Codes	8	Warranty	59
5.1 Gas Codes.....	8		
5.2 Aircraft Hangars	8		
5.3 Parking Structures and Repair Garages	8		
5.4 Electrical	8		
5.5 Venting.....	8		
5.6 High Altitude.....	8		
SECTION 6: Heater installation	9		
6.1 General	9		
6.2 Suspension	9		
SECTION 7: Venting	10		
7.1 Venting.....	10		
7.2 Vent Installation	10		
7.3 Horizontal Venting.....	11		
7.4 Vertical Venting	11		
7.5 Maximum Vent Lengths Table.....	11		
7.6 Vent Material	11		
7.7 Replacing an Existing Heater in a Venting System.....	11		
SECTION 8: Air Supply	17		
8.1 Separated Combustion Installation	17		
8.2 Building Ventilation.....	17		
8.3 Outside Combustion Air Supply	17		
SECTION 9: Gas Piping	18		
9.1 Connections.....	18		
SECTION 10: Wiring	20		
10.1 Positioning Thermostats.....	20		
SECTION 11: Operation and Maintenance	29		
11.1 Pre-Start-Up Checks.....	29		
11.2 Begin Start-Up	30		
11.3 Pressure Switch	34		
11.4 Turning Off the Heater.....	34		
11.5 External Controls	34		
11.6 Complete the Start-Up.....	34		
11.7 Instruction to the User.....	34		

© 2014 Roberts-Gordon LLC

All rights reserved. No part of this work covered by the copyrights herein may be reproduced or copied in any form or by any means - graphic, electronic, or mechanical, including photocopying, recording, taping or information storage and retrieval systems - without the written permission of Roberts-Gordon LLC.

Printed in U.S.A.

TABLE OF FIGURES

Figure 1: UHA[T][M][X][S]150 - 250 Label Placement	2
Figure 2: UHA[T][M][X][S]300 - 400 Label Placement	3
Figure 3: Installation Clearances and Clearances to Combustibles	7
Figure 4: Suspension Methods	9
Figure 5: Vent and Roof Detail	12
Figure 6: Standard Vented Heater - Vertical and Horizontal Vent Termination.....	13
Figure 7: Standard Vented Heater - Common Vertical Vent Termination	14
Figure 8: Separated Combustion Heater - Vertical and Horizontal Vent Termination	15
Figure 9: Concentric Vent Box.....	15
Figure 10: Concentric Vertical and Horizontal Vent Termination - Separated Combustion Heater	16
Figure 11: Gas Connection.....	19
Figure 12: Automatic Burner Control Sequence	30
Figure 13: Single Stage Gas Valve for Models UHA[X][S] 150 - 400	31
Figure 14: Two Stage Gas Valve for Models UHA[T][X][S] 150 - 400	31
Figure 15: Modulating Gas Valve for Models UHA[M][X][S] 150 - 400	32
Figure 16: LED Diagnostic Codes	36

There are references in this manual to various trademarks. All trademarks mentioned herein, whether registered or not, are the property of their respective owners. Roberts-Gordon LLC is not sponsored by or affiliated with any of the trademark or registered trademark owners, and makes no representations about them, their owners, their products or services.



SECTION 1: HEATER SAFETY

Your Safety is Important to Us!
This symbol is used throughout the manual to notify you of possible fire, electrical or burn hazards. Please pay special attention when reading and following the warnings in these sections.

Installation, service and, at a minimum, annual inspection of heater must be done by a contractor qualified in the installation and service of gas-fired heating equipment.

Read this manual carefully before installation, operation or service of this equipment.

Heaters are not approved for residential installation. These instructions, the layout drawing, local codes and ordinances and applicable standards that apply to gas piping, electrical wiring, venting, etc. must be thoroughly understood before proceeding with the installation.

Protective gear is to be worn during installation, operation and service in accordance to the Occupational Safety and Health Administration (OSHA). Gear must be in accordance to NFPA 70E, latest revision when working with electrical components. Thin sheet metal parts have sharp edges. To prevent injury, the use of work gloves is recommended.

Before installation, check that the local distribution conditions, nature of gas and pressure and adjustment of the equipment are compatible.

The heater must be applied and operated under the general concepts of reasonable use and installed using the best building practices.

This equipment is not intended for use by persons (including children) with reduced physical, sensory or mental capabilities, or lack of experience and knowledge, unless they have been given supervision or instruction concerning use of the equipment by a person responsible for their safety. Children should be supervised to ensure that they do not play with the equipment.

For additional copies of the Installation, Operation and Service Manual, please contact Roberts-Gordon LLC.

1.1 Manpower Requirements

To prevent personal injury and damage to the heater, two persons will be required for installation.

1.2 Safety Labels and Their Placement

Product safety signs or labels should be replaced by the product user when they are no longer legible.

Please contact Roberts-Gordon LLC or your ROBERTS GORDON® independent distributor to obtain replacement signs or labels. See *Page 2, Figure 1 through Page 3, Figure 2*.

1.3 California Proposition 65

In accordance with California Proposition 65 requirements, a warning label must be placed in a highly visible location on the outside of the equipment (i.e. near equipment's serial plate). See label placement drawing on *Page 2, Figure 1 through Page 3, Figure 2* for label location. Avoid placing label on areas with extreme heat, cold, corrosive chemicals or other elements. To order additional labels, please contact Roberts-Gordon LLC or your ROBERTS GORDON® independent distributor.

Figure 1: UHA[T][M][X][S]150 - 250 Label Placement

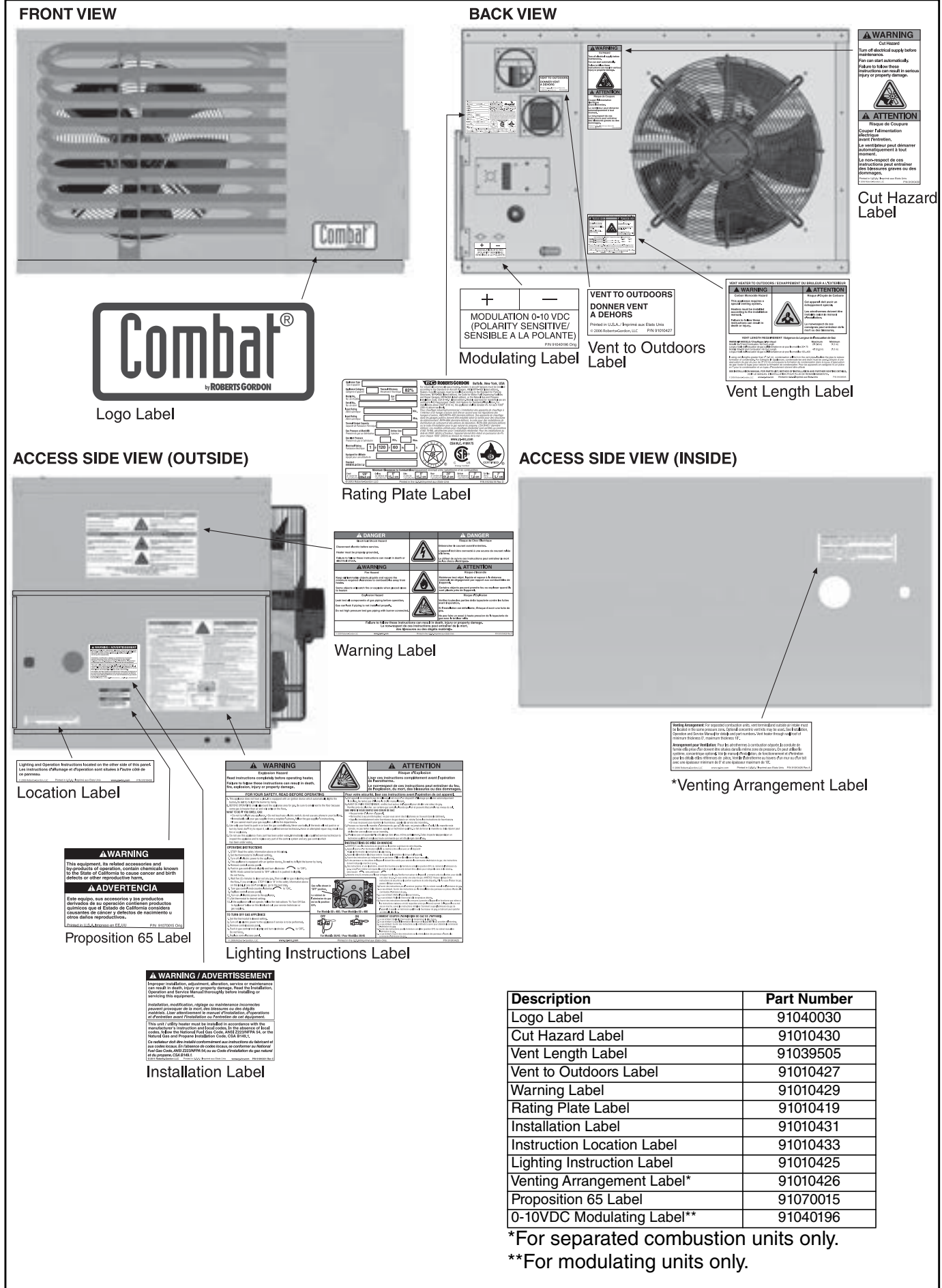

Description	Part Number
Logo Label	91040030
Cut Hazard Label	91010430
Vent Length Label	91039505
Vent to Outdoors Label	91010427
Warning Label	91010429
Rating Plate Label	91010419
Installation Label	91010431
Instruction Location Label	91010433
Lighting Instruction Label	91010425
Venting Arrangement Label*	91010426
Proposition 65 Label	91070015
0-10VDC Modulating Label**	91040196

*For separated combustion units.
 **For modulating units only.

Figure 2: UHA[T][M][X][S]300 - 400 Label Placement

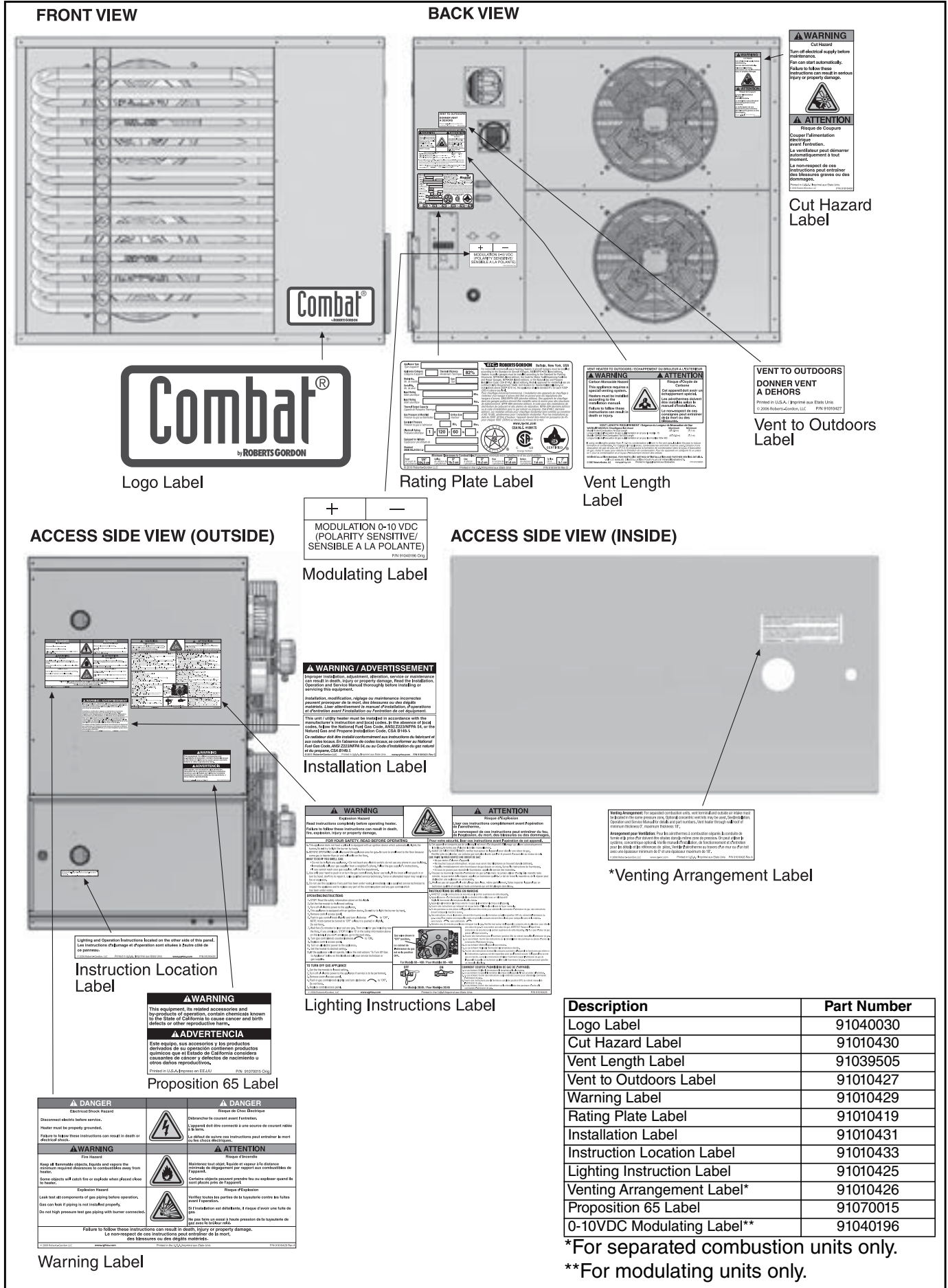

SECTION 2: INSTALLER RESPONSIBILITY

The installer is responsible for the following:

- To install the heater, as well as the gas and electrical supplies, in accordance with applicable specifications and codes. Roberts-Gordon LLC recommends the installer contact a Local Building Inspector or Fire Marshal for guidance.
- To use the information given in a layout drawing and in the manual together with the cited codes and regulations to perform the installation.
- To install the heater in accordance with the clearances to combustibles.
- To furnish all needed materials not supplied as standard equipment.
- To plan location of supports, vents and air intakes.
- To provide access for servicing.
- To provide the owner with a copy of this Installation, Operation and Service Manual.
- To never use heater as support for a ladder or other access equipment and never hang or suspend anything from heater.
- To ensure there is adequate air circulation around the heater and to supply air for combustion, ventilation and distribution in accordance with local codes.
- To ensure that the heater is placed in an approved application.

2.1 Wall Tag

A laminated wall tag is included with the heater as a permanent reminder of the safety instructions and the importance of the required clearances to combustibles. Affix the tag by peeling off the backing of the adhesive strips on the rear surface and position the tag on a wall near the heater.

A copy of the wall tag (P/N 91040031) is illustrated on the back cover.

Know your model number and installed configuration. Model number and installed configuration are found on the heater serial plate and throughout the Installation, Operation and Service Manual.

2.2 Corrosive Chemicals

 CAUTION

<p>Product Damage Hazard</p> <p>Do not use equipment in area containing corrosive chemicals.</p> <p>Refer to appropriate Material Safety Data Sheets (MSDS).</p> <p>Failure to follow these instructions can result in product damage.</p>

Roberts-Gordon LLC cannot be responsible for ensuring that all appropriate safety measures are undertaken prior to installation; this is entirely the responsibility of the installer. It is essential that the contractor, the sub-contractor, or the owner identifies the presence of combustible materials, corrosive chemicals or halogenated hydrocarbons* anywhere in the premises.

** **Halogenated Hydrocarbons** are a family of chemical compounds characterized by the presence of halogen elements (fluorine, chlorine, bromine, etc.). These compounds are frequently used in refrigerants, cleaning agents, solvents, etc. If these compounds enter the air supply of the burner, the life span of the heater components will be greatly reduced. An outside air supply must be provided to the burners whenever the presence of these compounds is suspected. Warranty will be invalid if the heater is exposed to halogenated hydrocarbons.*

2.3 National Standards and Applicable Codes

All equipment must be installed in accordance with the latest revision of the applicable standards and national codes. This refers also to the electric, gas and venting installation. Note: Additional standards for installations in public garages, aircraft hangars, etc. may be applicable. See Page 8, Section 5.

SECTION 3: CRITICAL CONSIDERATIONS

3.1 Basic Information

UHA[T][M][X][S] heaters have automatic ignition burners for ON/OFF, HIGH/LOW or modulate within the range of HIGH/LOW operation.

3.2 Manufactured Units

Gas-fired, power-vented unit heater with tubular heat exchanger. Units shall have a minimum of 82% thermal efficiency. The standard unit shall consist of a non-separated combustion design with an aluminized heat exchanger and single stage gas valve. Design and heat exchanger alternatives shall be offered as follows:

- Separated Combustion: [S] A separated combustion unit shall consist of a sealed enclosure with a hinged door. Combustion air inlet on rear of heater allows for intake venting from outside of heated space to be attached. Combustion flue gases shall be ducted from outside heated space by ductwork connected to unit's outlet flange.
- Stainless Steel Heat Exchanger: [X] A stainless steel heat exchanger unit shall consist of heat exchanger tubes, heat exchanger tube supports and heat exchanger tube plate produced of 409 stainless steel. Air inlet temperatures below 40 °F (4.5 °C) are not recommended for this application.
- Two Stage Gas Valve: [T] A two-stage gas valve shall allow heater to function in either high or low fire.
- Modulating Gas Valve: [M] A modulating gas valve shall allow heater to modulate between high and low fire.

3.3 Location and Suspension

All models:

- Must be installed indoors.
- Must be installed in a level position with horizontal discharge.
- May be mounted on a shelf of non-combustible material.
- May be suspended from above (See Page 9, Figure) or from wall brackets of sufficient strength to support the heater as listed in the Technical Data Table on Page 56, Section 16.2 and Page 58, Section 16.5.

- Drop rods must be a minimum of 3/8" diameter mild steel. Four suspension points (3/8" nuts) are located on top of the heater.
- Must be installed in a manner which allows access to all serviceable components.

3.4 Minimum Required Installation Clearances

Clearances around the heater and vent must be as indicated on Page 7, Figure 3 and Page 10, Section 7 to ensure access for servicing and correct operation.

3.5 Ventilation

It is important to ensure that there is adequate air space around the heater to supply air for combustion, ventilation and distribution in accordance with local and national codes on Page 10, Section 7.

3.6 Gas Supply

It is important that the gas supply pipe is sized correctly to provide the inlet pressure as stated on the heater serial plate. The gas supply pipe and electrical connections must not support any of the heater's weight. See Page 18, Section 9.

3.7 Electrical Supply

A permanent 120 V / 1 Ø / 60 Hz electrical supply is required for the main electrical power. The heater also requires suitable controls in accordance with Page 20, Section 10.

3.8 Vent

Choose heater orientation to allow for the proper location of the vent. Each heater must be fitted with a correctly sized sealed vent system.

If vented horizontally, no other equipment may be connected to the vent. See Page 10, Section 7.

SECTION 4: CLEARANCES TO COMBUSTIBLES**4.1 Required Clearances to Combustibles**

! WARNING

Fire Hazard
Keep all flammable objects, liquids and vapours the minimum required clearances to combustibles away from heater.
Some objects will catch fire or explode when placed close to heater.
Failure to follow these instructions can result in death, injury or property damage.

Clearances are the required distances that combustible objects must be away from the heater to prevent a fire hazard. Combustibles are materials that may catch on fire and include common items such as wood, paper, rubber, fabric, etc. Maintain clearances to combustibles at all times for safety.

Clearances for all heater models are located on the serial plate of the heater and throughout the manual. Check the clearances on the serial plate to make sure the product is suitable for your application and the clearances are maintained. Read and follow the safety guidelines below:

- Keep gasoline or other combustible material including flammable objects, liquids, dust or vapors away from this heater or any other equipment.
- Do not spray aerosols in the vicinity of this heater.
- The stated clearances to combustibles represents a surface temperature of 90° F (50° C) above room temperature. Building materials with a low heat tolerance (such as plastics, vinyl siding, canvas, tri-ply, etc) may be subject to degradation at lower temperatures. It is the installer's and owner's responsibility to assure that adjacent materials are protected from degradation.
- Maintain clearances from heat sensitive equipment and workstations.
- Consult local Fire Marshal, Fire Insurance Carrier or other authorities for approval of proposed installation when there is a possibility of

exposure to combustible airborne materials or vapors.

4.2 Clearances to Combustibles

Clearances must be as indicated on *Page 7, Figure 3*. If clearances to combustibles are not indicated, then installation clearances apply.

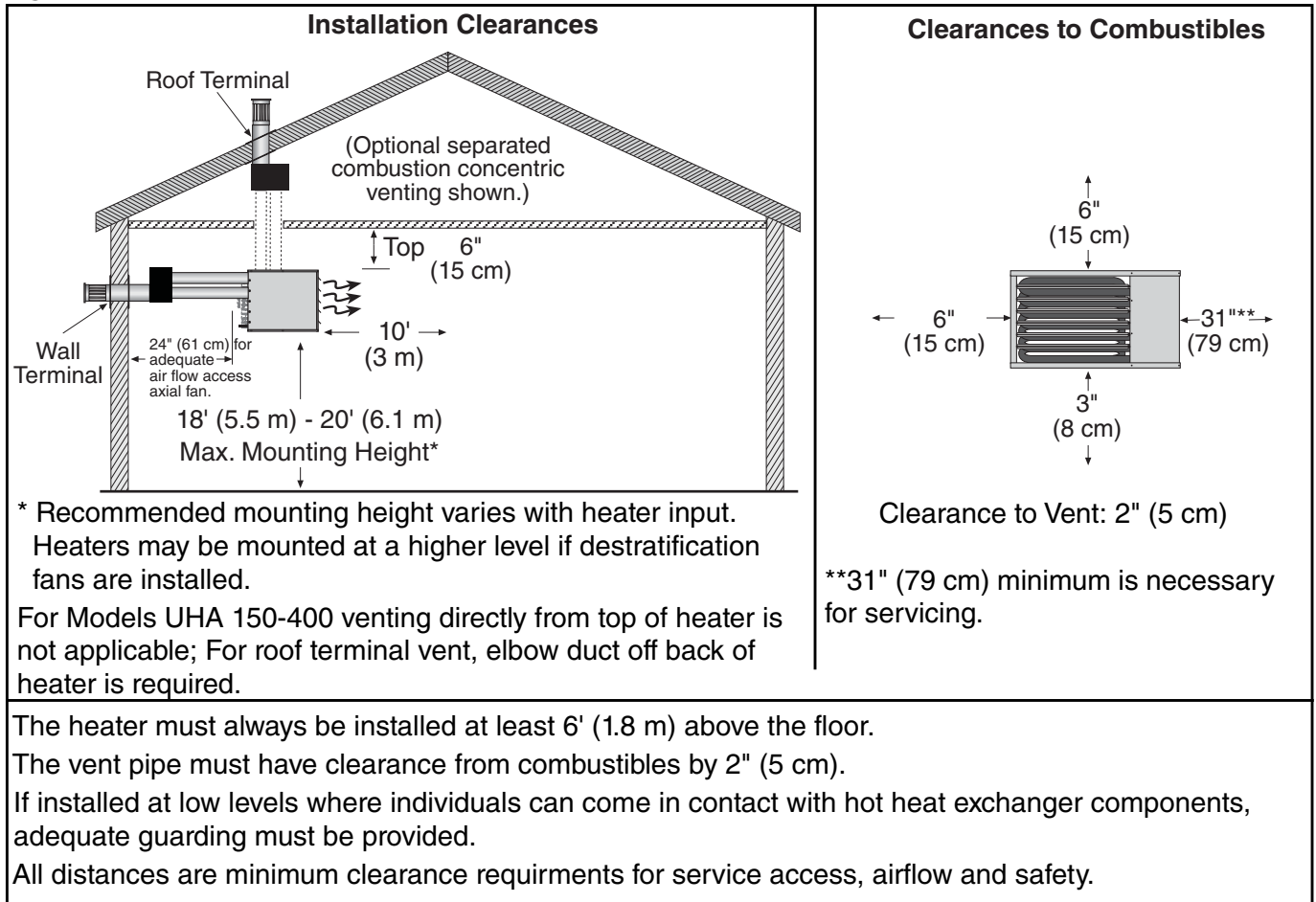
Figure 3: Installation Clearances and Clearances to Combustibles

SECTION 5: NATIONAL STANDARDS AND APPLICABLE CODES

5.1 Gas Codes

The type of gas appearing on the serial plate must be the type of gas used. Installation must comply with national and local codes and requirements of the local gas company.

United States: Refer to NFPA 54/ANSI Z223.1 - latest revision, National Fuel Gas Code.

Canada: Refer to CSA B149.1 Natural Gas and Propane Installation Code.

5.4 Electrical

The heater must be electrically grounded in accordance with the following codes:

United States: Refer to National Electrical Code®, NFPA 70 - latest revision. Wiring must conform to the most current National Electrical Code®, local ordinances and any special diagrams furnished.

Canada: Refer to Canadian Electrical Code, CSA C22.1 Part 1 - latest revision.

5.2 Aircraft Hangars

Installation in aircraft hangars must be in accordance with the following codes:

United States: Refer to Standard for Aircraft Hangars, NFPA 409 - latest revision.

Canada: Refer to Natural Gas and Propane Installation Code, Standard CSA B149.1 - latest revision.

5.5 Venting

The venting must be installed in accordance with the requirements within this manual and the following codes:

United States: Refer to NFPA 54/ANSI Z223.1 - latest revision, National Fuel Gas Code.

Canada: Refer to CSA B149.1 Natural Gas and Propane Installation Code.

5.3 Parking Structures and Repair Garages

Installation in garages must be in accordance with the following codes:

United States: Refer to Standard for Parking Structures, NFPA 88A - latest revision or the Code for Motor Fuel Dispensing Facilities and Repair Garages, NFPA 30A - latest revision.

Canada: Refer to Natural Gas and Propane Installation Code, Standard CSA B149.1 - latest revision.

5.6 High Altitude

These heaters are approved (without modifications) for installations up to 2000' (610 m) in US and Canada. Heaters installed above 2000' (610 m) must be de-rated. For installations above 2000' (610 m) in US, consult factory for information on burner de-rating. For installations from 2000' (610 m) to 4500' (1370m) in Canada, high altitude conversion kits are available. Heaters installed over 4500' (1370 m) in Canada are not approved and must be approved by the local or provincial authority.

SECTION 6: HEATER INSTALLATION**6.1 General**

Heaters are designed for installation above 6' (1.8 m). These heaters must be installed within the heated space. Duct delivery systems are not permitted with axial fan units. When handling or supporting the heater from below, ensure that the weight is taken at the support points.

The gas or electrical supply lines must not be used to support the heater.

Do not locate the gas or electrical supply lines directly over the path of the flue products from the heater.

The heater must be installed in a location that is readily accessible for servicing.

The heater must be installed in accordance with clearances to combustibles as indicated on the wall tag and in this manual.

6.2 Suspension

⚠ WARNING	
	Crush Hazard
	<p>Use 3/8" threaded rod minimum.</p> <p>Failure to follow these instructions can result in death, injury or property damage.</p>

For typical suspension, See Page 9, Figure 4.

Figure 4: Suspension Methods

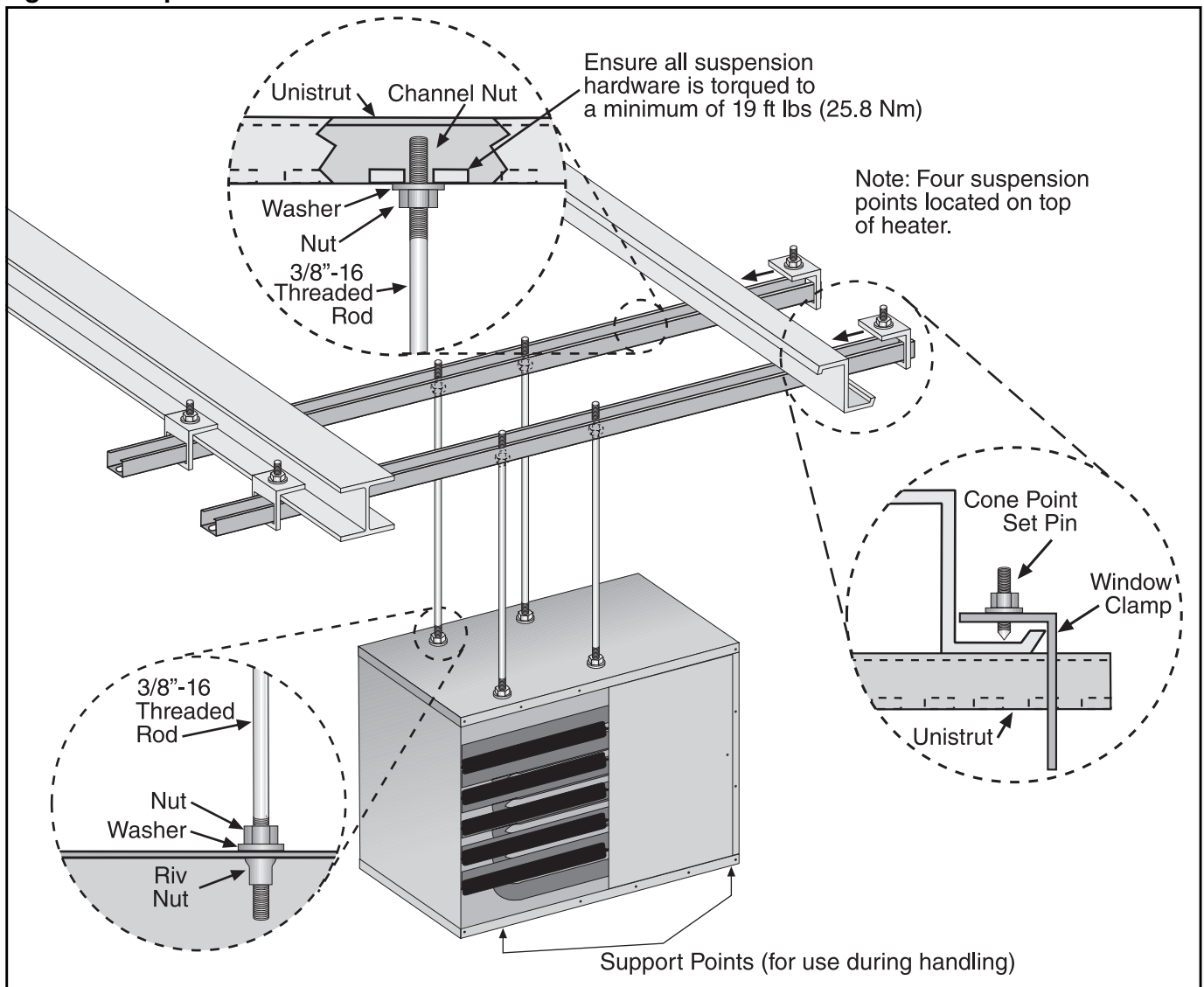

SECTION 7: VENTING

⚠ WARNING	
	Carbon Monoxide Hazard
	Heaters must be vented outdoors.
	Heaters must be installed according to the installation manual.
	Failure to follow these instructions can result in death or injury.

7.1 Venting

This heater must be vented in accordance with the rules contained in this manual and with the following national codes and any state, provincial or local codes which may apply: **United States:** Refer to NFPA 54/ANSI Z223.1 - latest revision, National Fuel Gas Code; **Canada:** Refer to CSA B149.1 Natural Gas and Propane Installation Code.

The bottom of the vent or air intake terminal shall not be located less than 1' (.3 m) above grade level.

The vent shall not terminate less than 7' (2.1 m) above grade where located adjacent to public walkways.

Vent terminal must be installed at a height sufficient to prevent blockage by snow and building materials protected from degradation by flue gasses.

Vent terminal must be beyond any combustible overhang.

Secure all joints with corrosion resistant #8 x 3/8" sheet metal screws.

For single wall venting, pressure sensitive aluminum tape or silicone sealant must be used to seal all joints.

Aluminum tape shall have a minimum temperature rating of 400° F (204° C) and meet SMACNA AFTS-100-73 standards. High temperature silicone sealant must have a minimum temperature rating of 480° F (250° C).

7.1.1 United States Requirements

Vent must terminate at least 3' (.9 m) above any forced air inlet located within 10' (3.1 m).

Vent must terminate at least 4' (1.2 m) below, 4' (1.2 m) horizontally from, or 1' (.3 m) above any door, operable window, or gravity air inlet into any building.

NFPA 54/ANSI Z223.1 - latest revision, National Fuel Gas Code specifies a 4' (1.2 m) horizontal vent terminal clearance from gas and electric meters,

regulators and relief equipment.

7.1.2 Canadian Requirements

The vent shall not terminate within 6' (1.8 m) of a mechanical air supply inlet to any building.

The vent shall not terminate within 3' (.9 m) of a window or door that can be opened in any building, any non-mechanical air supply inlet to any building, or of the combustion air inlet of any other piece of equipment.

7.2 Vent Installation

Maintain clearances to combustibles at all times for safety. Clearances are the required distances that combustible objects must be away from the heater to prevent serious fire hazard. See Page 7, Figure 3. For vented units, the vent must terminate outside of the building.

Vents must be fully sealed and correctly sized for the model. If the vent passes through a wall or ceiling of combustible material, it must be enclosed by a listed thimble and be separated from the thimble by at least a 2" (5 cm) air gap.

For separated combustion models, vents and air intakes must be a fully sealed system and correctly sized for the model. Vent should be assembled as detailed on Page 12, Figure 5 through Page 16, Figure 10. The joints between the vent terminal and the roof or wall must be properly sealed. If the vent passes through a wall or ceiling of combustible material, it must be enclosed by a listed thimble and be separated from the thimble by at least a 2" (5 cm) air gap.

Vents and air intakes must be adequately supported so that the heater does not bear the weight of the pipes.

For vent termination See Page 12, Figure 5 through Page 16, Figure 10.

7.2.1 Standard Vented Heaters (Models UHA[T][M][X] 150-400)

The vent must be fitted with a low resistance terminal. See Page 12, Figure 5 through Page 14, Figure 7. Standard vented heaters do not allow outdoor air intake for combustion air.

7.2.2 Separated Combustion Heaters (Models UHA[T][M][X]S 150-400)

The heaters are designed to be installed as separated combustion heaters. The vent and air intake are run as separate pipes to the wall or roof terminals. See Page 15, Figure 8. As an option, the vent and air intake are run as separate pipes to a

concentric vent box and a concentric vent/air intake pipe penetrates the wall or roof. See *Page 15, Figure 9 and Page 16, Figure 10*.

For separated combustion installation, the vent and air intake must be fitted with an individual and correctly sized sealed system and the vent and air intake must terminate at approved wall and roof terminals.

Separated combustion units may not be common vented.

7.3 Horizontal Venting

Horizontally vented heaters must be individually vented, no common venting.

Vent pipe must be sloped $\frac{1}{4}$ " (.6 cm) for every 1' (.3 m).

In noncombustible walls only, vent terminal (P/N 02537801-1P) may be used.

For 4" (10 cm) vents in either combustible or noncombustible walls, use vent terminal (P/N 90502100) or equivalent insulated vent terminal. Follow the manufacturer's instructions for proper installation.

Instead of an insulated vent terminal, a listed thimble with 2" (5 cm) air gap, may be used with a 4" (10 cm) vent cap (P/N 90502102).

7.4 Vertical Venting

Vertically vented standard vented heaters can be common vented (up to 4 heaters).

Vent pipe must be sloped $\frac{1}{4}$ " (.6 cm) for every 1' (.3 m).

For 4" (10 cm) common vent, an approved vent cap (P/N 90502102) must be used.

For 6" (15 cm) common vent, an approved vent cap (P/N 90502103) must be used.

For common vertical venting of more than two heaters, See *Page 14, Figure 7*.

A vent shall not extend less than 2' (.6m) above the highest point where it passes through a flat roof of a building.

7.5 Maximum Vent Lengths Table

Model UHA[T][M][X][S]150-400	# of Elbows
30 ft (9.1 m)	1
25 ft (7.6 m)	2
20 ft (6.1 m)	3
15 ft (4.5 m)	4
10 ft (3.0 m)	5

7.6 Vent Material

Vent material may be single wall 26 ga. (minimum) galvanized steel or equal thickness stainless steel.

Completely seal all joints, refer to *Page 10, Section 7.2*.

If penetrating a combustible wall or roof, a listed thimble with 2" (5 cm) clearance must be used. Where local codes permit, a single section of type B-1 vent material may be used at the roof or wall penetration instead of a thimble. Ensure vent manufacturer's clearance from vent material is maintained. Seal annular space of the type B-1 vent as well as all joints in the remaining vent.

7.7 Replacing an Existing Heater in a Venting System

When replacing an existing heater in a venting system, the venting system may not be properly sized to vent the new heater. The following steps must be followed with each piece of equipment connected to the venting system placed in operation, while any other equipment connected to the venting system are not in operation.

1. Seal any unused openings in the venting system.
2. Inspect the venting system for proper size and horizontal pitch, as required by the NFPA 54/ANSI Z223.1 - latest revision, National Fuel Gas Code (US) or Standard CSA B149.1 Natural Gas and Propane Installation Code (Canada) and these instructions. Determine that there is no blockage or restriction, leakage, corrosion and other deficiencies which could cause an unsafe condition.
3. Close all building doors and windows and all doors between the space in which the piece(s) of equipment connected to the venting system are located and other spaces of the building. Turn on clothes dryers and any exhaust fans, such as range hoods and bathroom exhausts so that they shall operate at maximum speed. Do not operate a summer exhaust fan. Close fireplace dampers.
4. Follow the lighting instructions. Place the equipment being inspected in operation. Adjust thermostat so that the equipment will operate continuously.
5. For any equipment having a draft hood, test for draft hood equipment spillage at the draft hood relief opening after five minutes of main burner operation. Use the flame of a match or candle.
6. After it has been determined that each piece(s) of equipment connected to the venting system properly vents when tested as outlined above, return doors, windows, exhaust fans, fireplace

dampers and any other gas-burning piece(s) of equipment to their previous conditions of use.

7. If improper venting is observed during any of the above tests, the venting system must be corrected by a contractor qualified in the installation and service of gas-fired equipment or your local gas supplier. If the venting must be resized, use appropriate tables in (US) Appendix G of NFPA 54/ANSI Z223.1 - latest revision, National Fuel Gas Code (US) or Standard CSA B149.1 Natural Gas and Propane Installation Code (Canada) to determine minimum size. All vent corrections must be in accordance with the appropriate local codes and the NFPA 54/ANSI Z223.1 - latest revision, National Fuel Gas Code (US) or Standard CSA B149.1 Natural Gas and Propane Installation Code (Canada).

Figure 5: Vent and Roof Detail

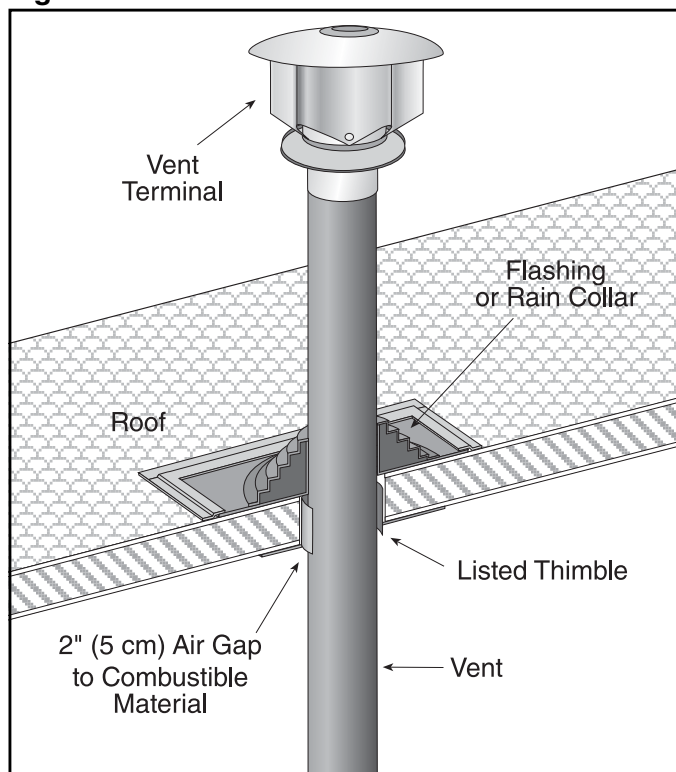
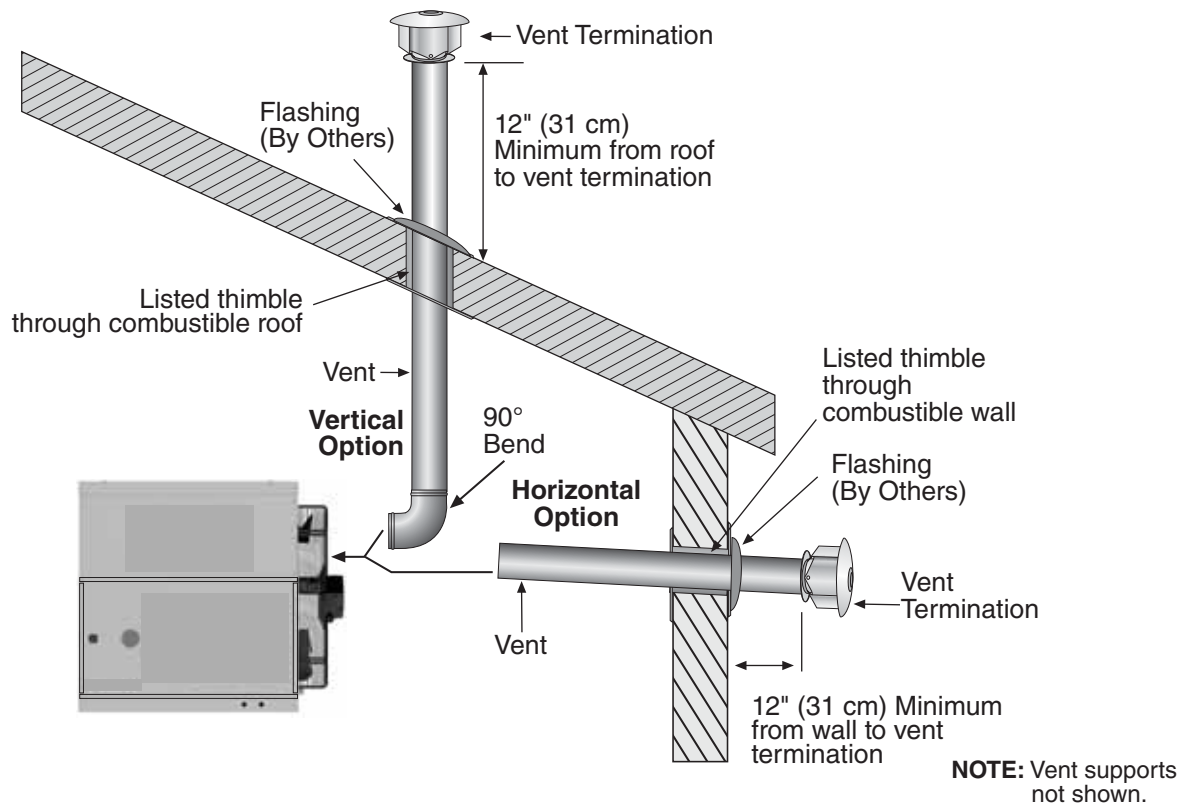
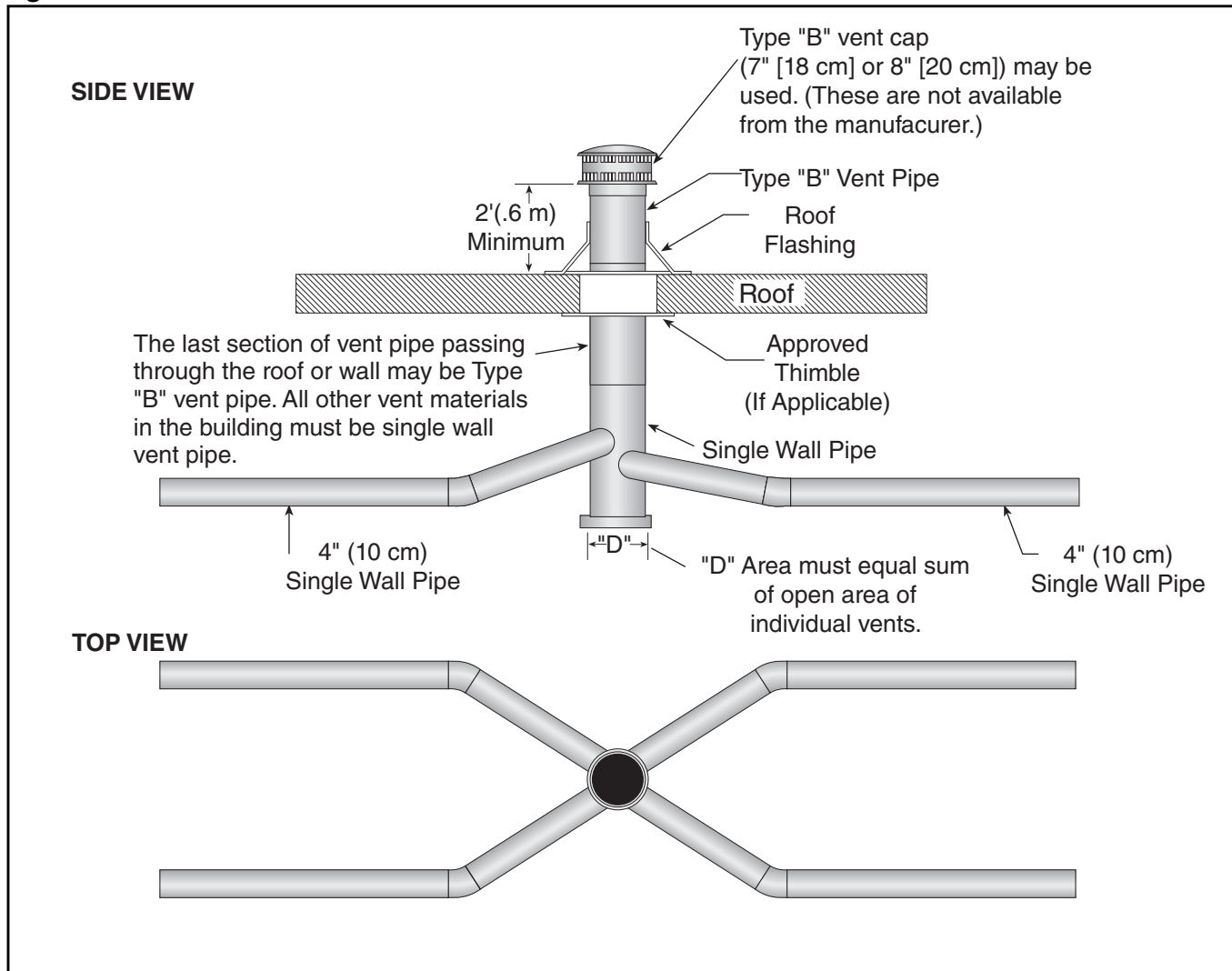

Figure 6: Standard Vented Heater - Vertical and Horizontal Vent Termination



Model	Vent Diameter	Part Number
UHA[T][M][X] 150-400	4" (10 cm)	90502102

Figure 7: Standard Vented Heater - Common Vertical Vent Termination



Requirements:

- Maximum of four heaters can be commonly vented through the roof.
- Heaters must be of the same BTU output.
- Heaters must be controlled by a common thermostat.
- Connections to a common stack must be positioned to avoid direct opposition between streams of combustion gases.

Figure 8: Separated Combustion Heater - Vertical and Horizontal Vent Termination

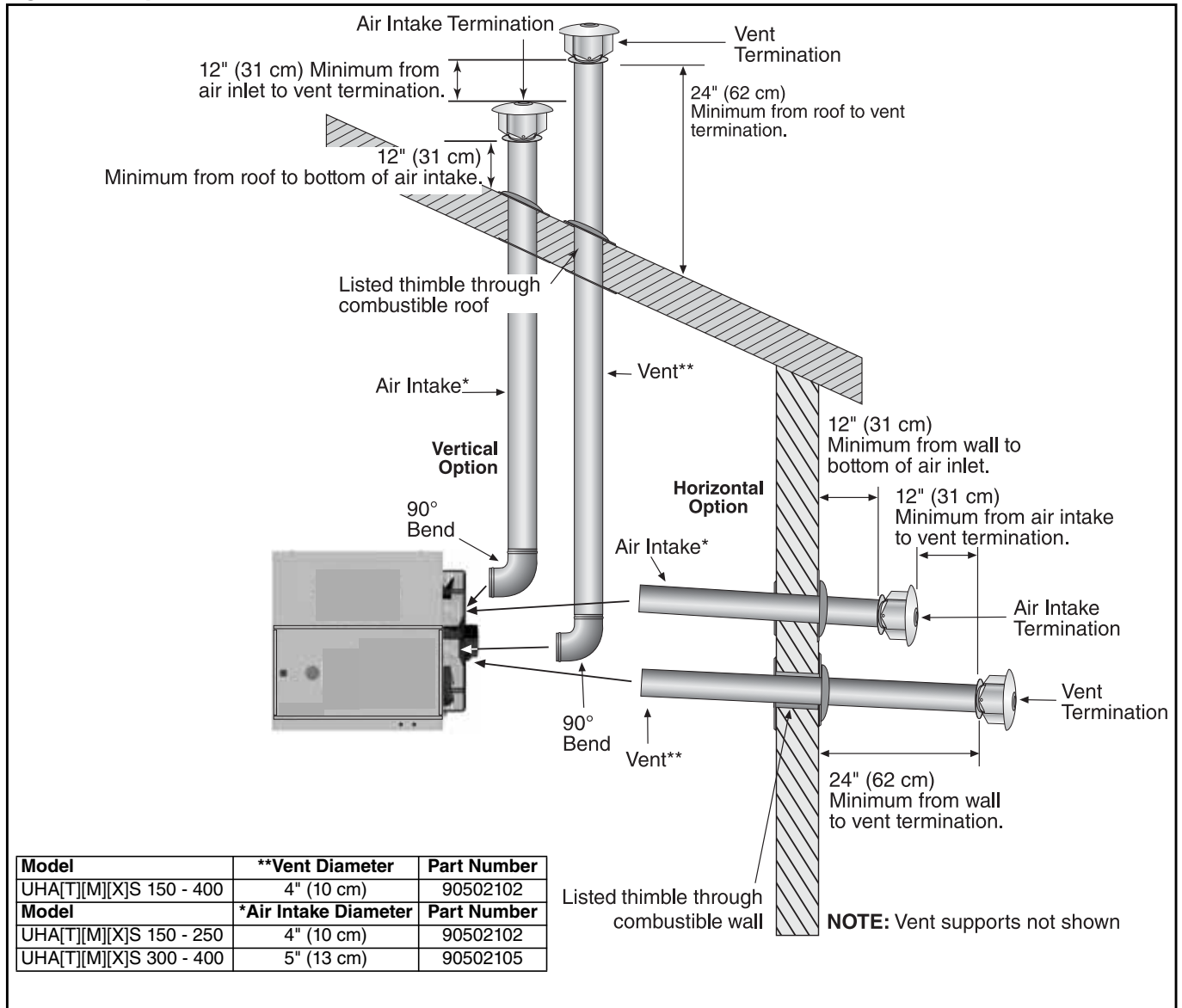

Figure 9: Concentric Vent Box

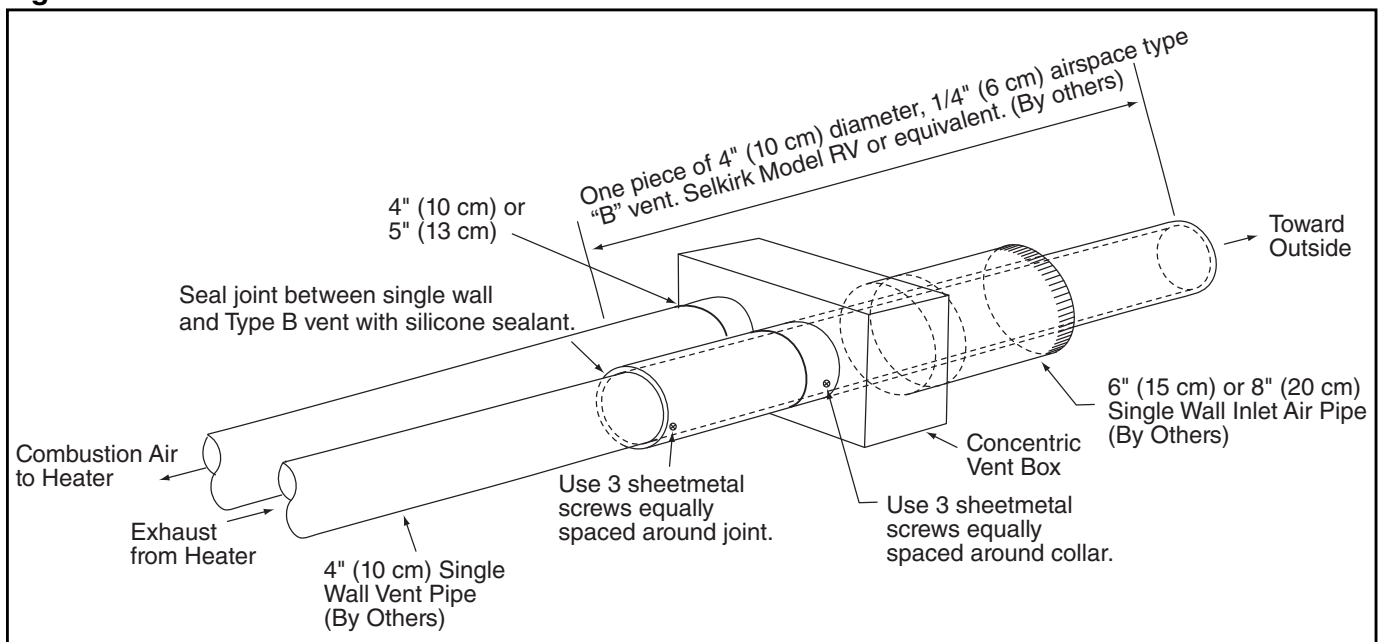
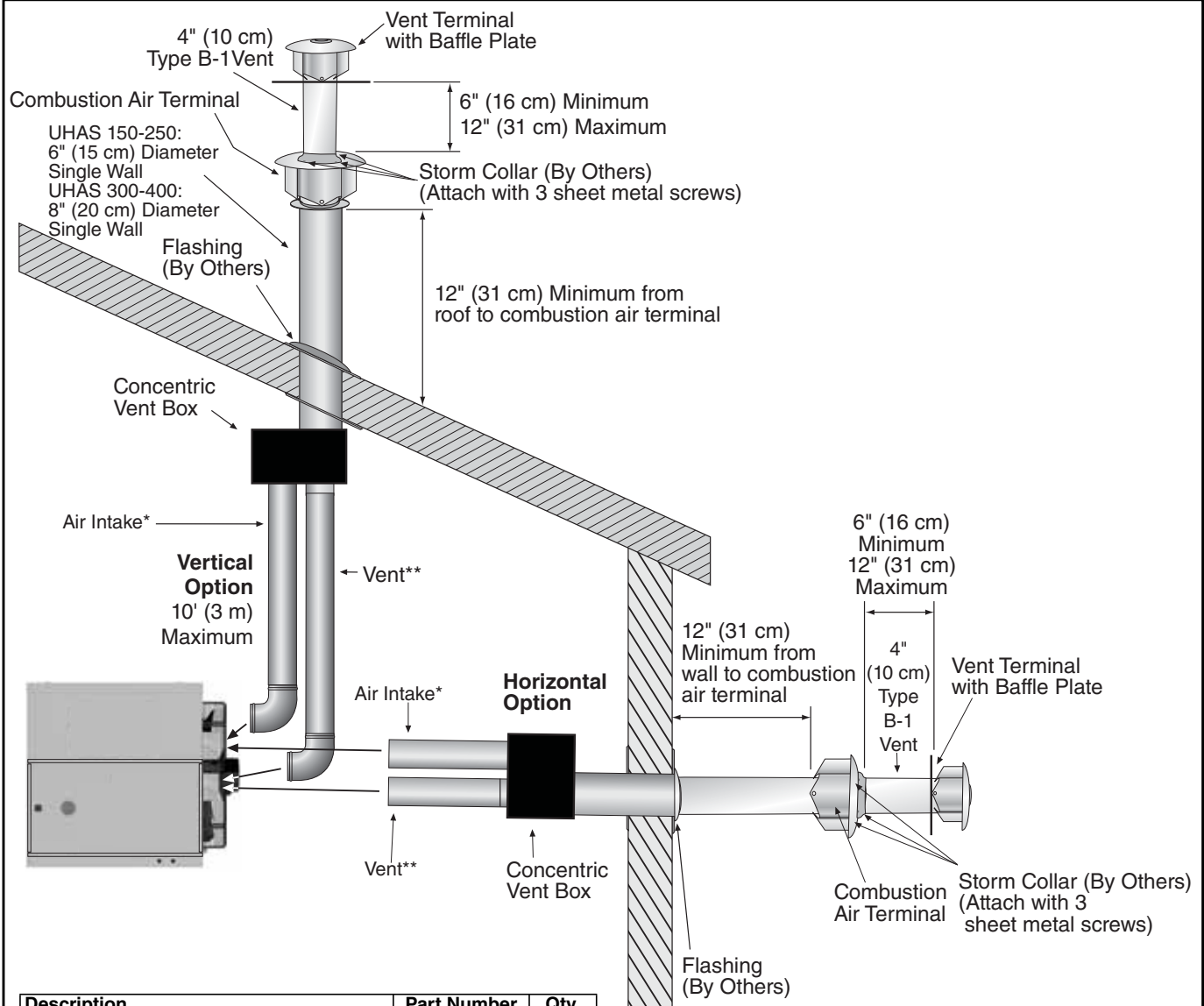

Figure 10: Concentric Vertical and Horizontal Vent Termination - Separated Combustion Heater



Description	Part Number	Qty.
Concentric Vent Kit (150 - 250)	UHVK1	
Concentric Vent Box Top & Side Assembly	90504113	1
Concentric Vent Box Bottom Assembly	90504112	1
Screw #6 x 3/8 Self Drilling	91119100	14
4" Vent Terminal with Baffle Plate	90502102R	1
6" Combustion Air Terminal	90502103	1

Description	Part Number	Qty.
Concentric Vent Kit (300 - 400)	UHVK2	
Concentric Vent Box Top & Side Assembly	90504013	1
Concentric Vent Box Bottom Assembly	90504012	1
Screw #6 x 3/8 Self Drilling	91119100	14
4" Vent Terminal with Baffle Plate	90502102R	1
8" Combustion Air Terminal	90502104	1

Model	**Vent Diameter
UHA[T][M][X]S 150 - 400	4" (10 cm)
Model	*Air Intake Diameter
UHA[T][M][X]S 150 - 250	4" (10 cm)
UHA[T][M][X]S 300 - 400	5" (13 cm)

SECTION 8: AIR SUPPLY

⚠ WARNING

Explosion Hazard Equipment must have access to uncontaminated air at all times. Failure to follow these instructions can result in death, injury or property damage.

8.1 Separated Combustion Installation

When installed as a separated combustion heater (UHA[T][M][X]S), the air for combustion is drawn in from outside the building. It is important to ensure that there is adequate space around heater to provide air for the axial air distribution fan.

8.2 Building Ventilation

Where ventilation is required, air must be taken from an outside point where it is not likely to be contaminated or obstructed.

8.3 Outside Combustion Air Supply

If outside combustion air supply is required, separated combustion model (UHA[T][M][X]S) heaters must be used.

Caution: If the building has a slight negative pressure or corrosive contaminants such as halogenated hydrocarbons are present in the air, an outside combustion air supply to the heater is required. Seal all combustion air pipe joints. The outside air terminal must not be more than 1' (31 cm) above the vent terminal.

8.3.1 Length Requirements

Follow the constraints listed on *Page 11, Section 75*.

SECTION 9: GAS PIPING

! WARNING



Fire Hazard

Connect gas supply according to Figure 11.

Do not use gas supply pipe and electrical connections to support the heater's weight.

Gas can leak if not installed properly.

Failure to follow these instructions can result in death, injury or property damage.

! WARNING



Explosion Hazard

Leak test all components of gas piping before operation.

Gas can leak if piping is not installed properly.

Do not high pressure test gas piping with heater connected.

Failure to follow these instructions can result in death, injury or property damage.

A gas meter is connected to the service pipe by the gas supply company. An existing meter should be checked, preferably by the company, to ensure that the meter is adequate for the rate of gas supply required.

Installation pipes must be fitted in accordance with local and national codes. Pipes of smaller size than the heater inlet gas connection should not be used.

Gas lines must meet applicable codes:

United States: Flexible stainless steel gas hose (US models) is certified per the standard for connectors for gas equipment, ANSI Z21.21/CSA 6.10 - latest revision.

Canada: Rubber type 1 gas hose (Canadian models) is certified as being in compliance with the standard for elastomeric composite hose and hose couplings for conducting propane and natural gas, CAN/CGA 8.1 - latest revision.

9.1 Connections

Connect the heater to the gas supply ensuring that the final connections are as follows:

- Gas supply pipe work is run in medium or heavy gauge tubing in compliance with local and national codes.
- Meter and service must be large enough to handle all the burners being installed plus any other connected load. The gas pipe which feeds the system must be large enough to supply the required gas with a maximum pressure drop of 1/2 in wc. When gas piping is not included in the layout drawing, contact the local gas supplier.
- An isolating valve and union connection should be used and fitted into the supply adjacent to the heater.
- A minimum 1/8" NPT plugged tapping accessible for test connection must be installed immediately upstream of the gas supply connection to the heater.
- For suspended heaters, an approved metal flexible connection between the isolating valve and the heater may be used. **To reduce pressure loss, use one pipe size larger than the heater gas connection.**

IMPORTANT - The complete installation must be purged and tested for gas soundness in accordance with local and national codes.

Caution: Do not high pressure (in excess of 1/2 psi [14 in wc]) test the gas piping with the burner connected. Close manual shut-off valve during any pressure testing equal to less than 1/2 psi (14 in wc).

Check the pipe and tubing ends for leaks before placing heating equipment into service. When checking for gas leaks, use a soap and water solution; never use an open flame.

Figure 11: Gas Connection

⚠ CAUTION**Product Damage Hazard**

Hold gas nipple securely with pipe wrench
when attaching flexible gas connector.

Failure to follow these instructions can result
in product damage.

- Do not twist flexible gas connector.
- Ensure all joints are gas tight.

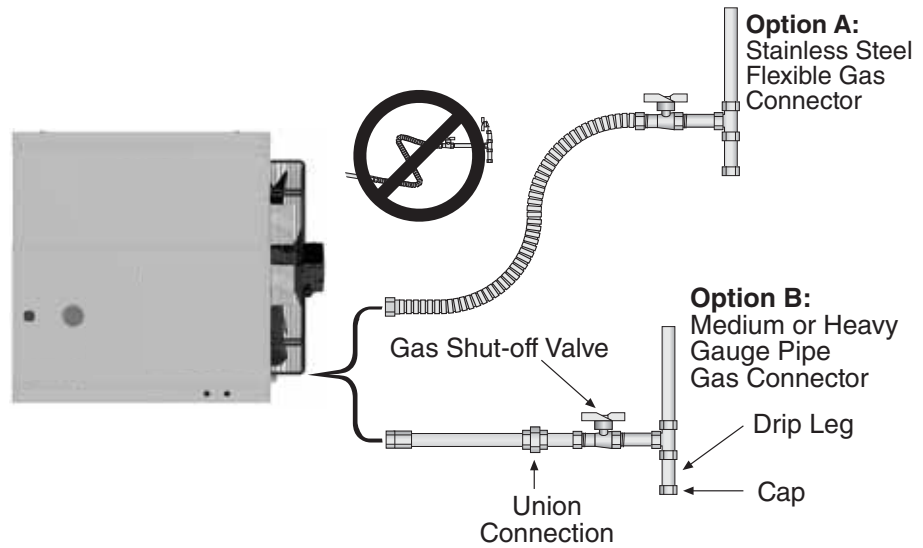

SECTION 10: WIRING

 <b style="font-size: 1.2em;">DANGER

<p style="text-align: center;">Electrical Shock Hazard</p> <p>Disconnect electric before service.</p> <p>More than one disconnect switch may be required to disconnect electric from equipment.</p> <p>Equipment must be properly grounded.</p> <p>Failure to follow these instructions can result in death or electrical shock.</p>

10.1.1 Fan Control

The heater’s axial fan can be used during the off-season for air circulation. A low voltage programmable thermostat with fan switch (P/N 90425400) must be used. For thermostat connection details See *Page 21, Section 10.2.*

All heater models require constant 120 V / 1Ø / 60 Hz power supply. Check heater serial plate for electrical rating for proper circuit sizing. For servicing, a disconnect switch of proper electrical rating should be installed in the vicinity of the heater.

All heaters are equipped with thermostat connections suitable to power a 24 V thermostat.

Heater must be wired and electrically grounded in accordance with local codes. In the absence of local codes in accordance with: United States: refer to National Electrical Code® NFPA 70 - latest revision
 Canada: refer to Canadian Electrical Code CSA C22.1 Part I - latest revision.

10.1 Positioning Thermostats

A room thermostat should be mounted on a vibration-free wall or column at a height of approximately 5' (1.5 m) from the floor to measure the ambient temperature. It should be clear of both cold drafts and the direct path of warm air from the heater.

Avoid mounting thermostat on outside walls or in areas directly exposed to radiant heat or sunlight. Install wall tag in a visible location near thermostat. See *Page 4, Section 2.1* for wall tag details.

10.2 Low Voltage Thermostat for Models UHA[T][M][X][S] 150-400

NOTE: Models 300-400 have two axial fans.

NOTE: Electrical supply is located below terminal strip.

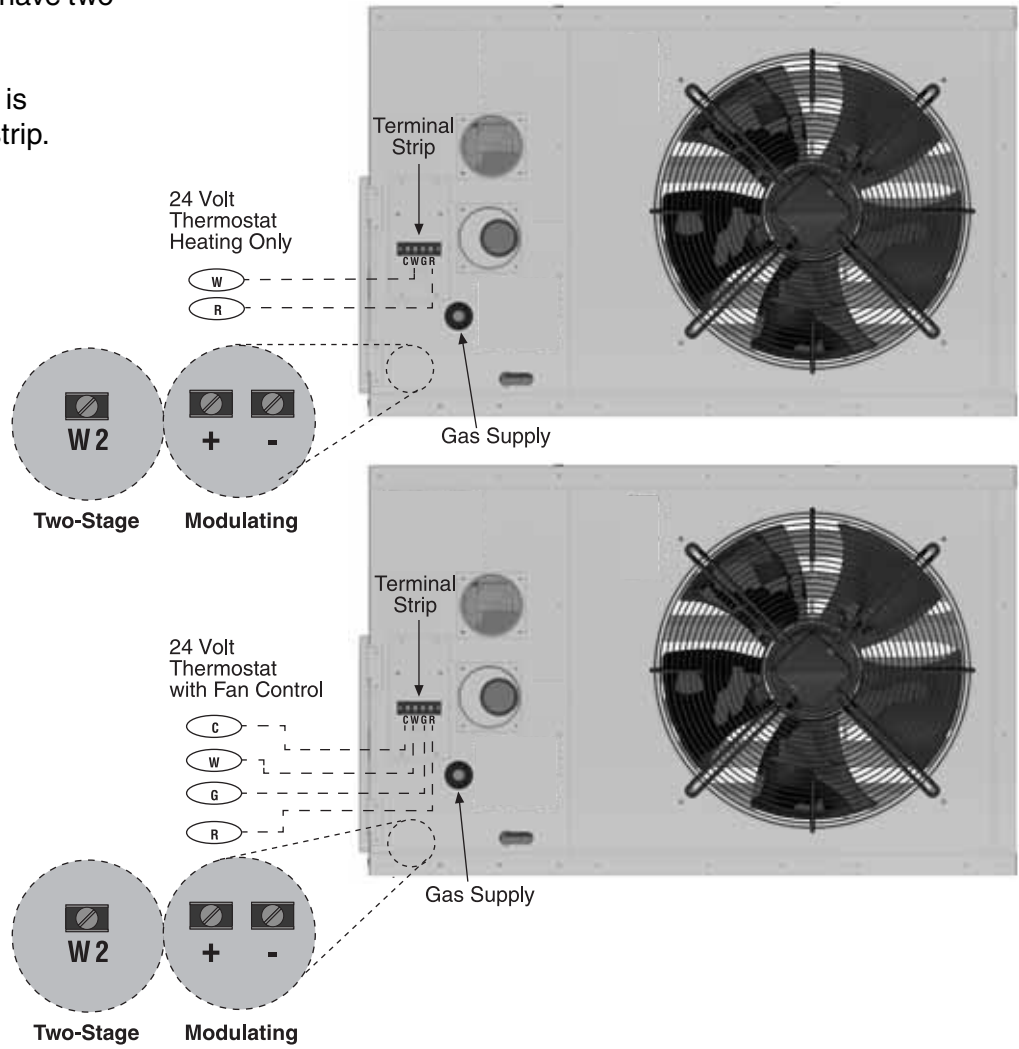

10.3 UHA[X][S] Series Internal Wiring Diagram for Single Stage Gas Valves

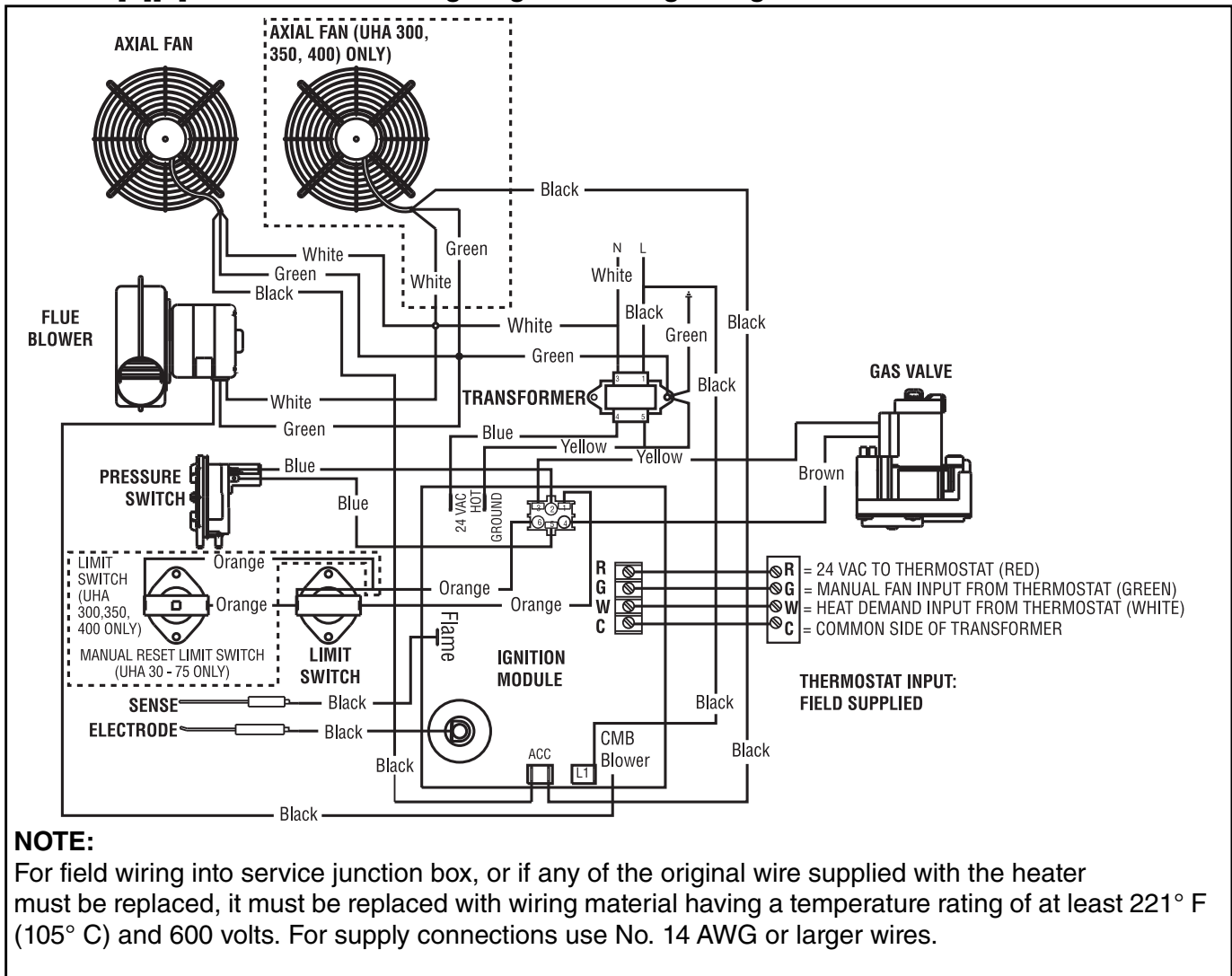

10.4 UHA[X][S] Series Ladder Wiring Diagram for Single Stage Gas Valves

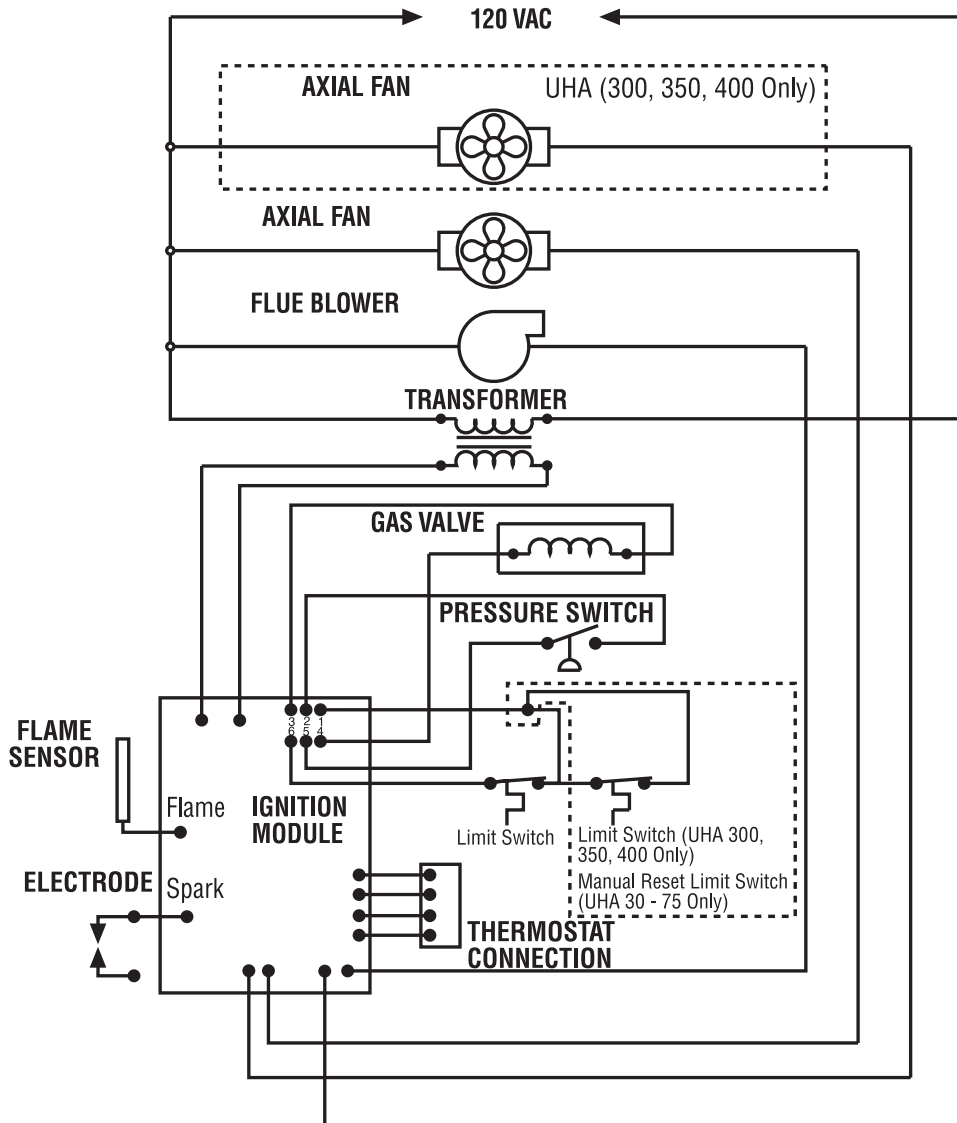
**NOTE:**

For field wiring into service junction box, or if any of the original wire supplied with the heater must be replaced, it must be replaced with wiring material having a temperature rating of at least 221° F (105° C) and 600 volts. For supply connections use No. 14 AWG or larger wires.

10.5 UHA[T][X][S] Series Internal Wiring Diagram for Two Stage Gas Valves

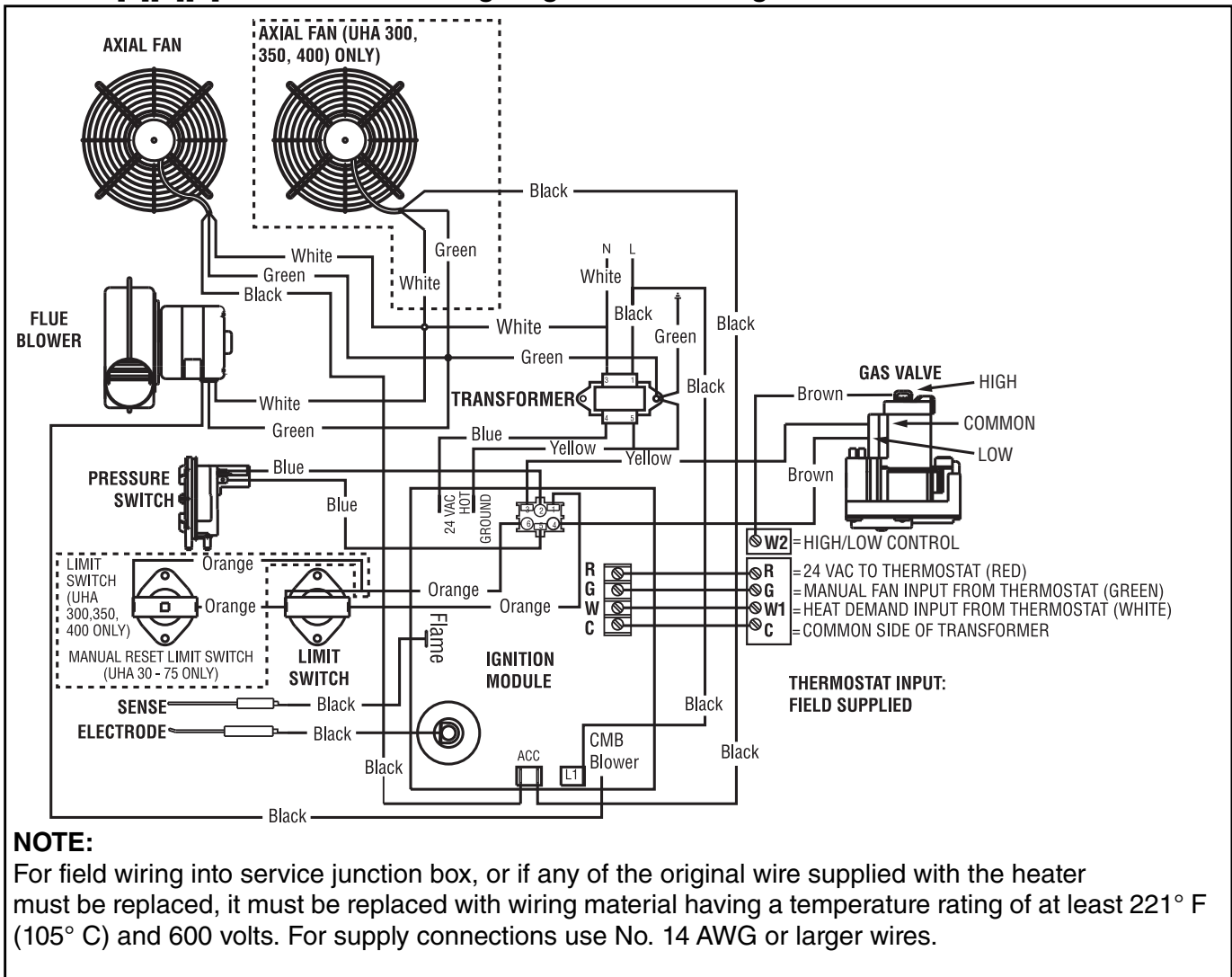

10.6 UHA[T][X][S] Series Ladder Wiring Diagram for Two Stage Gas Valves

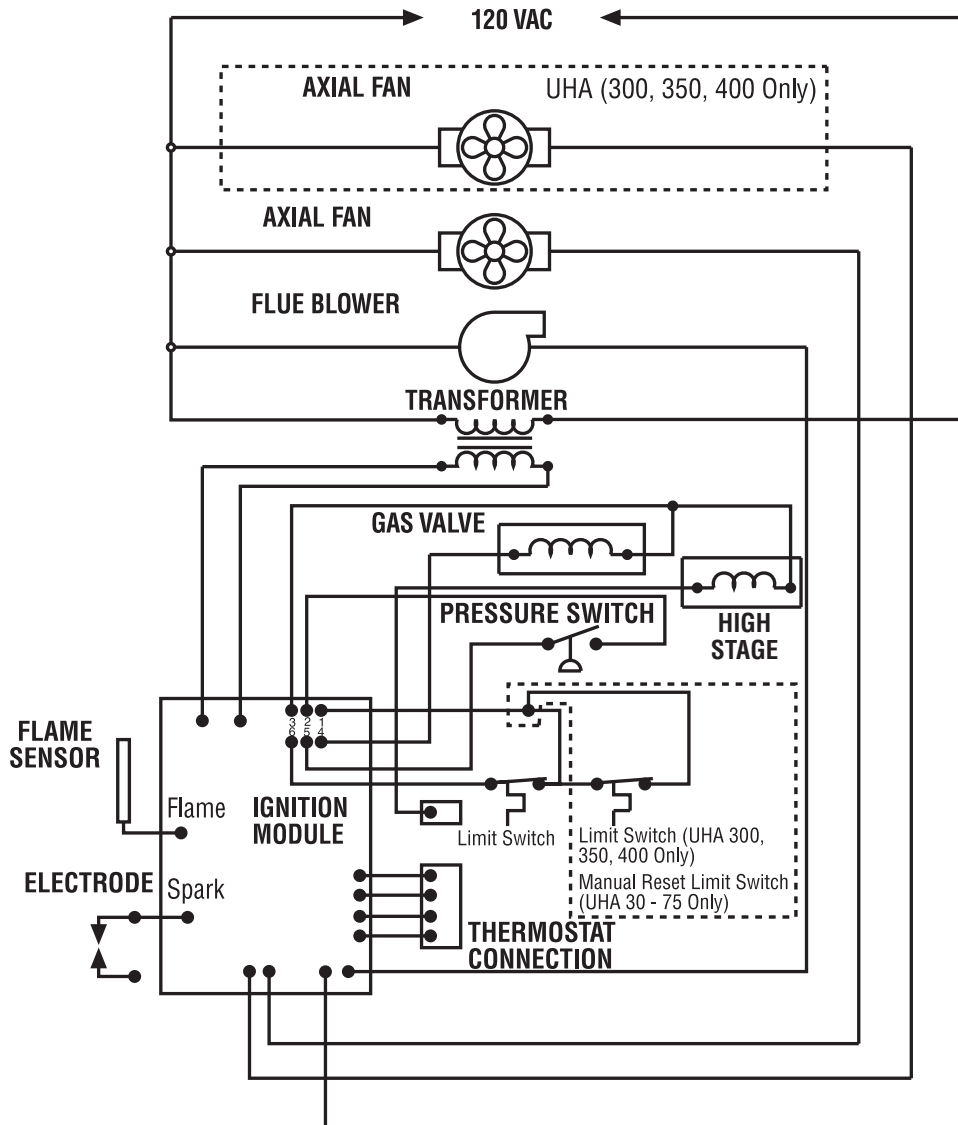
**NOTE:**

For field wiring into service junction box, or if any of the original wire supplied with the heater must be replaced, it must be replaced with wiring material having a temperature rating of at least 221° F (105° C) and 600 volts. For supply connections use No. 14 AWG or larger wires.

10.7 UHA[M][X][S] Series Internal Wiring Diagram for Modulating Gas Valves

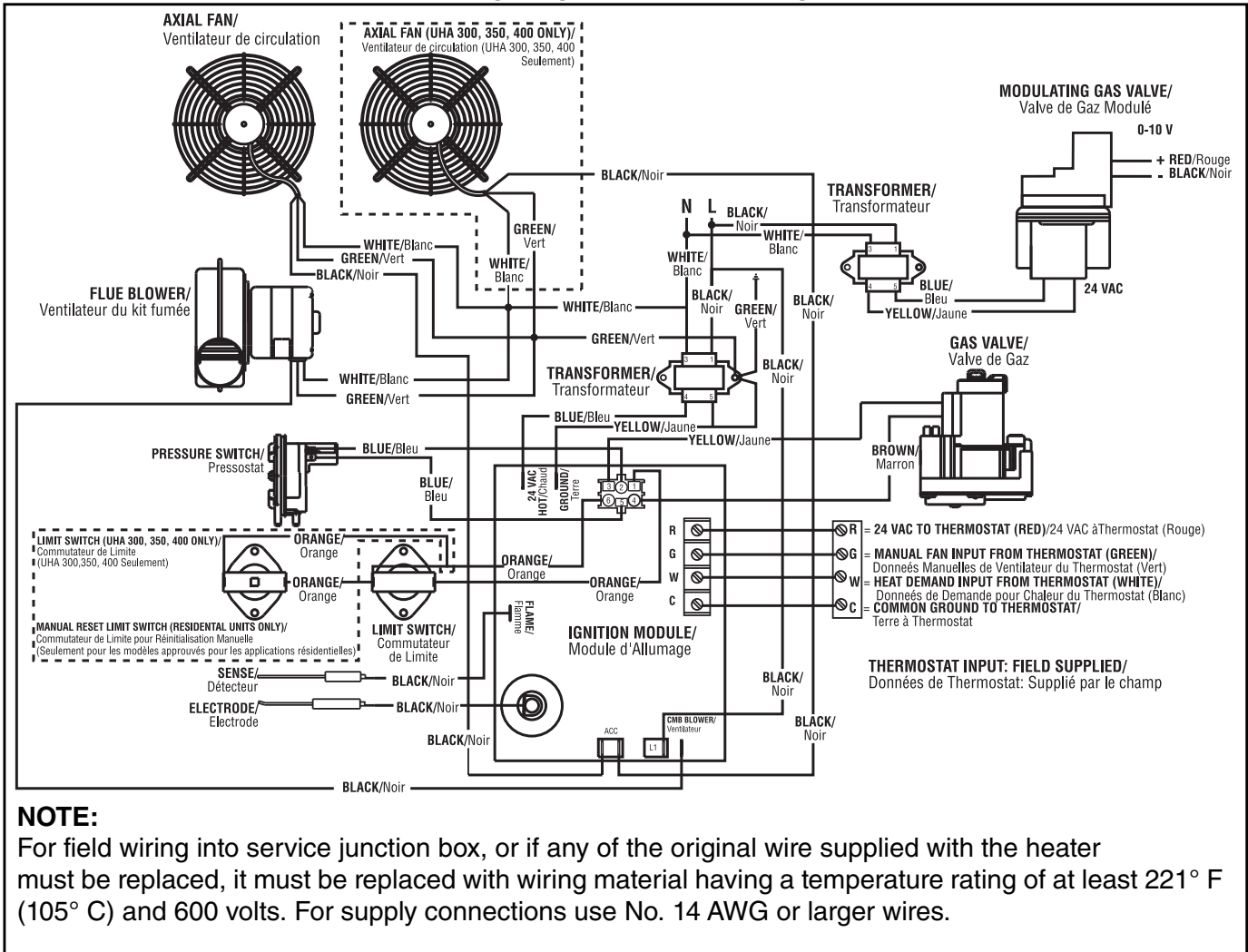

10.8 UHA[M][X][S] Series Ladder Diagram for Modulating Gas Valves

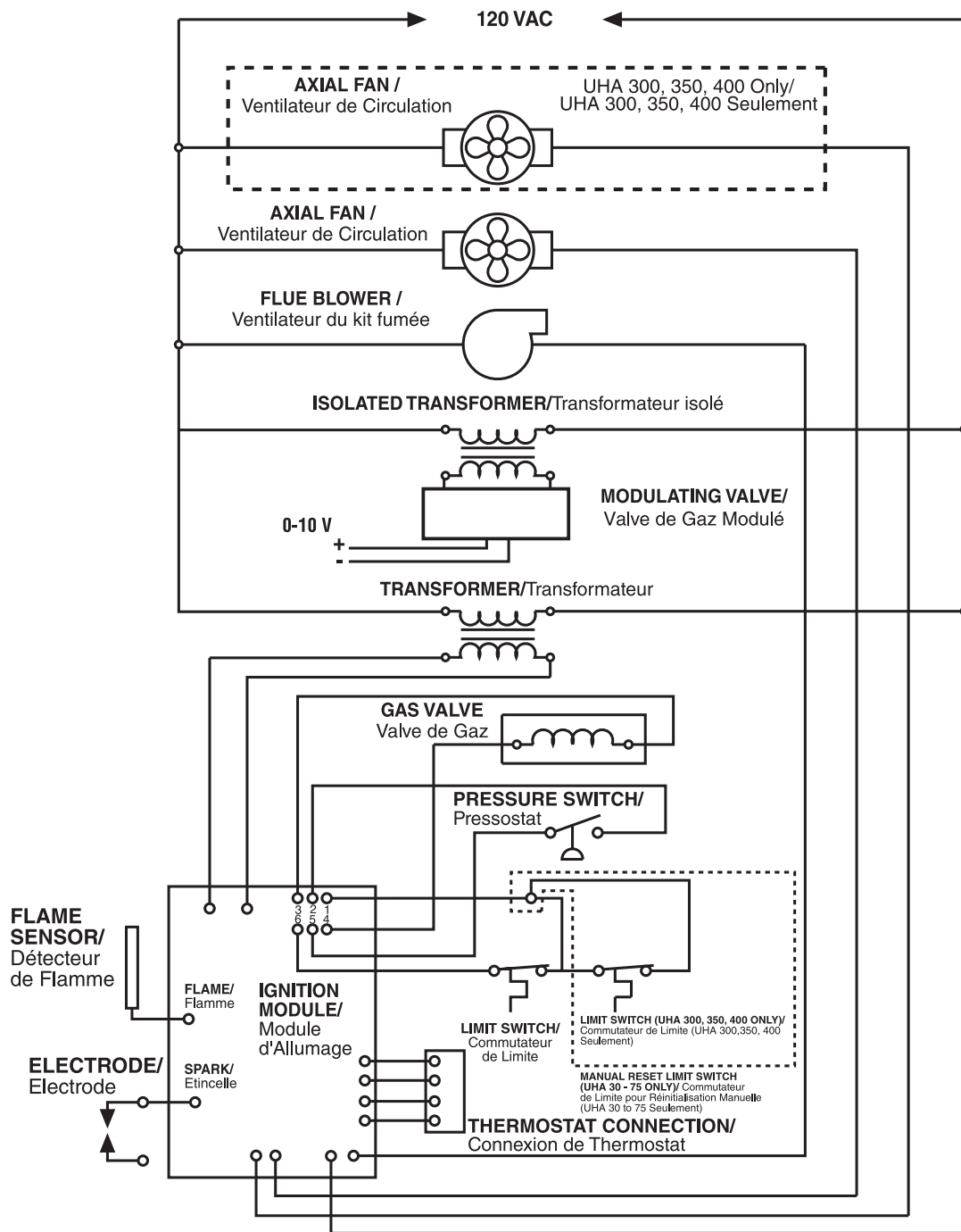
**NOTE:**



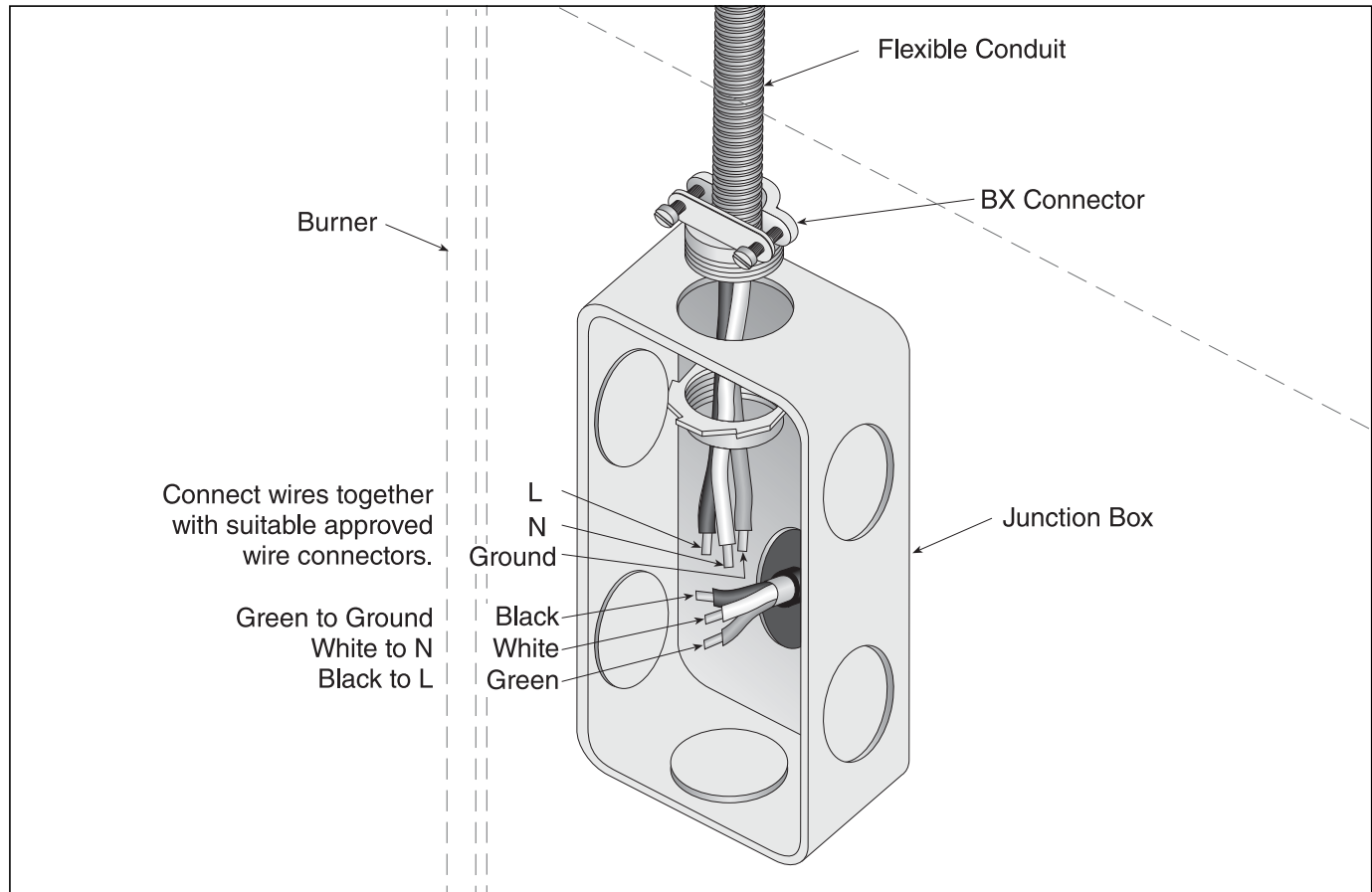

For field wiring into service junction box, or if any of the original wire supplied with the heater must be replaced, it must be replaced with wiring material having a temperature rating of at least 221° F (105° C) and 600 volts. For supply connections use No. 14 AWG or larger wires.

10.9 Electrical Connection to the Heater



Note: Junction box is not provided with heater.
Conduit can also be attached directly to heater with wire junction made within the heater cabinet.

SECTION 11: OPERATION AND MAINTENANCE

⚠ DANGER		⚠ WARNING	
			
Electrical Shock Hazard Disconnect electric before service. Heater must be connected to a properly grounded electrical source.	Explosion Hazard Turn off gas supply to heater before service.	Burn Hazard Allow heater to cool before service. Tubing may still be hot after operation.	Cut/Pinch Hazard Wear protective gear during installation, operation and service. Edges are sharp.
Failure to follow these instructions can result in death, electric shock, injury or property damage.			

Read this manual carefully before installation, operation, or service of this equipment. All components are accessed via the hinged door. Opening the door exposes live electrical connections and hot components. Prior to any maintenance or service of the heater, shut off, lockout and tagout the electrical disconnect and gas valve that supplies the unit in accordance with OSHA regulations.

11.1.2 Electrical Checks

1. Check that all site wiring is connected in accordance with the appropriate wiring diagram on Page 22, Section 10.3, Page 24, Section 10.5 or Page 26, Section 10.7.

11.1.3 Gas Supply

All aspects of the gas installation including the gas meter must be inspected, tested for gas tightness and purged in accordance with local and national codes.

Ensure that the air is fully purged from the heater inlet pipe up to the main gas valve inlet test nipple.

11.1.4 Mechanical Checks

1. Check that the fan(s) are free to run and delivery louvers are turned to give required air deflection.
2. Check that the flue (and air intake for separated combustion units) is installed in accordance with the instructions in this manual and local regulations. See Page 10, Section 7.

⚠ WARNING

Severe Injury Hazard Turn off gas and electrical supply before service. Fan can start automatically at any time. Failure to follow these instructions can result in severe injury or product damage.

11.1 Pre-Start-Up Checks

All pre-start-up checks must be carried out before lighting the heater.

Ensure that the heater and all controls are suitable for the gas, pressure and electrical supply to which they are to be connected.

11.1.1 Louvers

Where fitted, the air delivery louvers need to be set during start-up to give the required air distribution.

11.2 Begin Start-Up

11.2.1 Before Operating the Heater

To ensure that all the controls are in safe working order, operate the heater for the first time with the isolating gas valve turned off and power supply turned on.

1. Turn off the isolating gas valve.
2. Turn up the thermostat above room temperature. The automatic ignition sequence will now begin as described on Page 30, Figure 12.

There will be no ignition of the burner and lockout will occur, which proves the controls are operating correctly.

Figure 12: Automatic Burner Control Sequence

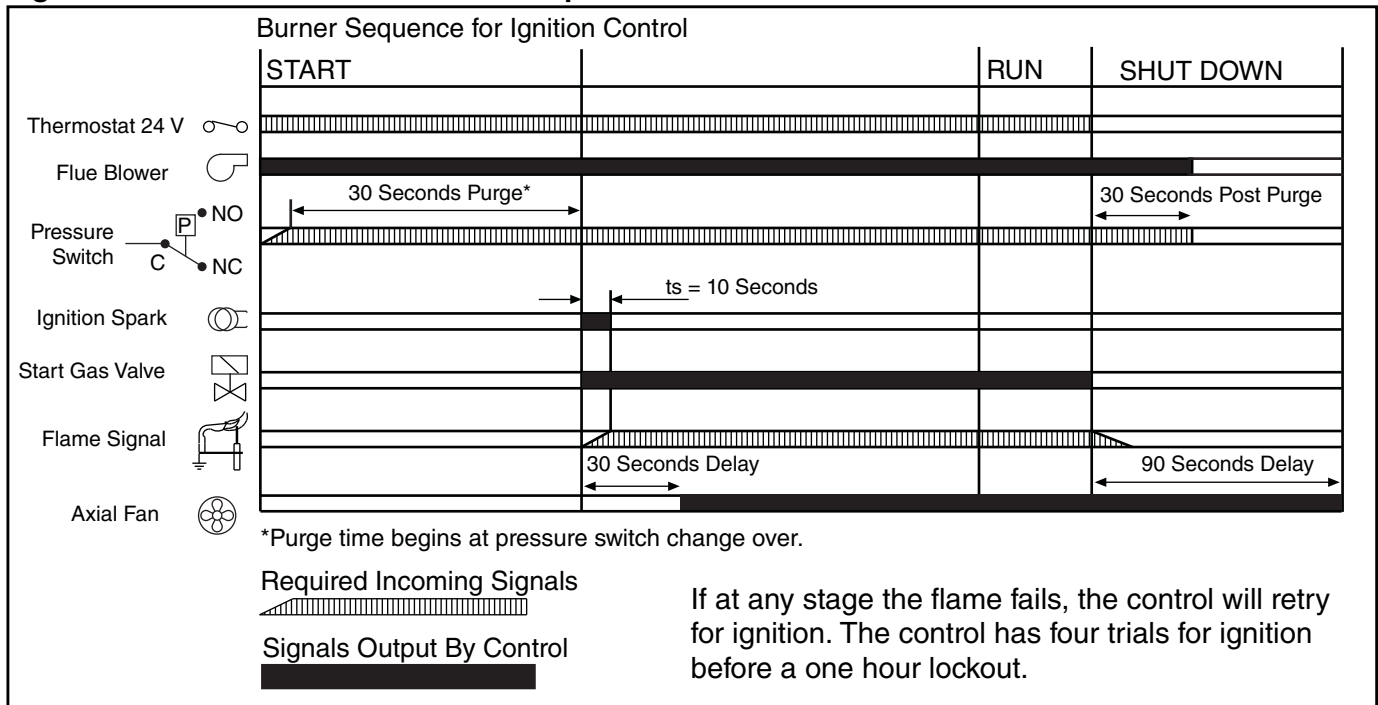

Figure 13: Single Stage Gas Valve for Models UHA[X][S] 150 - 400

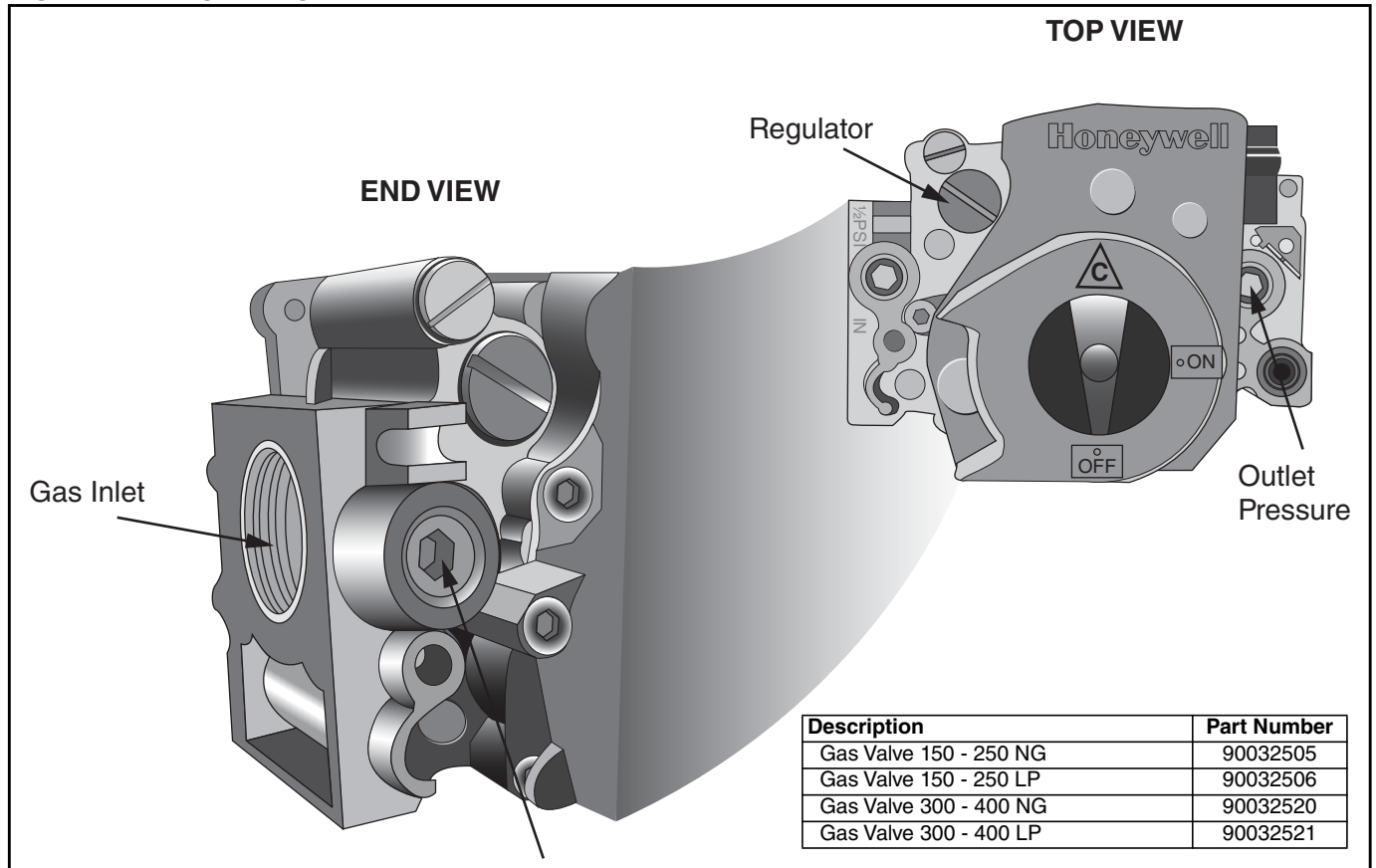

Figure 14: Two Stage Gas Valve for Models UHA[T][X][S] 150 - 400

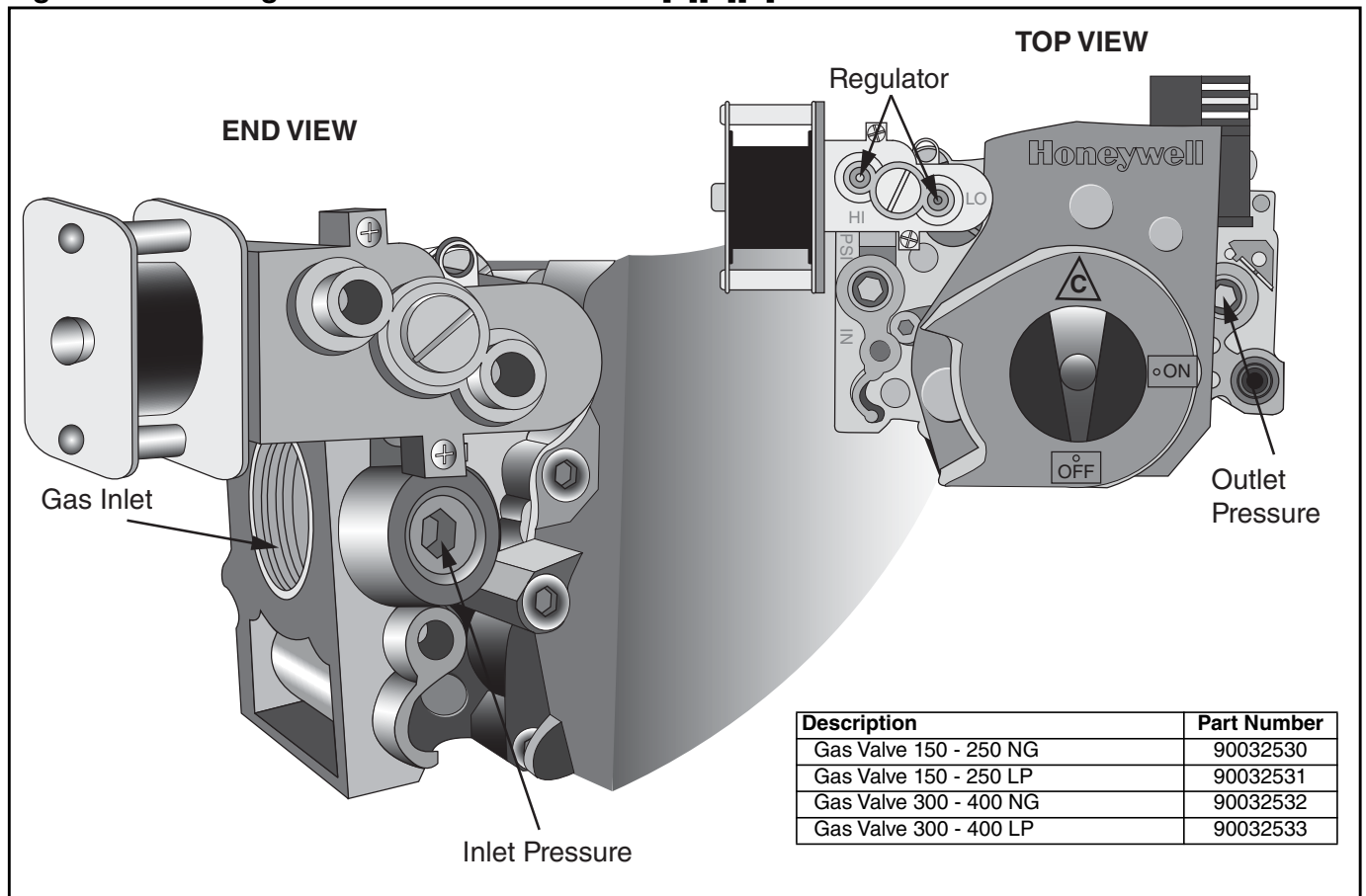
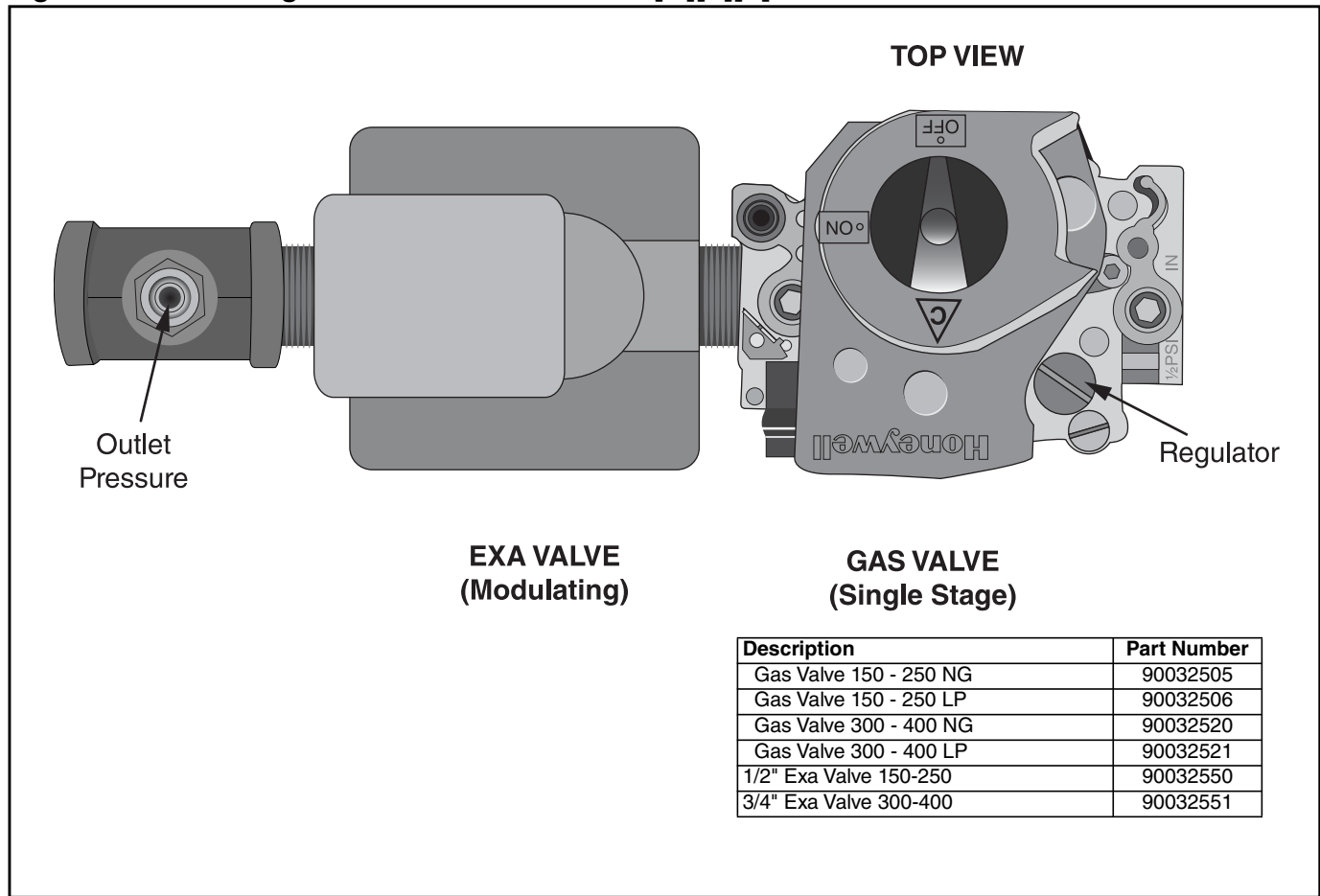

Figure 15: Modulating Gas Valve for Models UHA[M][X][S] 150 - 400



11.2.2 Start-Up the Gas Valve (All Gases)**11.2.2.1 Check Burner Gas Pressure (Single Stage)**

1. Remove the plug in the outlet (burner) pressure test point and connect a pressure tap and a manometer. *Page 31, Figure 13.*
2. With the burner firing, measure the pressure on the manometer. To adjust the burner pressure, remove the regulator cover from the valve and turn the regulator adjustment screw to set the required burner pressure as stated in the Technical Data Table for the correct gas and model *on Page 56, Section 16.3 and Page 58, Section 16.6.*

11.2.2.2 Check Burner Gas Pressure (Two Stage)

1. Remove the plug in the gas valve outlet pressure test point and connect a pressure tap and a manometer. *See Page 31, Figure 14.*
2. With the unit operating in high fire or low fire, measure the outlet pressure on the manometer. Measure burner pressure in both operating modes. To adjust the burner pressure, remove plastic cover from regulators and adjust High and/or Low regulators as needed. Required burner pressures are indicated in the Technical Data Table for the correct gas and model *on Page 56, Section 16.3 and Page 58, Section 16.6.*
3. To set the high fire rate, adjust the high fire adjustment on the gas valve. To set the low fire rate (with the unit running in low fire), adjust the low fire adjustment on the gas valve.

11.2.2.3 Check Burner Gas Pressure (Modulating)

1. Loosen screw in outlet pressure tap shown on *Page 32, Figure 15* and connect manometer. Gas pressure is NOT measured at Honeywell single stage gas valve.
2. With burner firing, measure pressure on manometer. To measure high fire burner pressure, disconnect modulating thermostat signal and apply 10 VDC to modulating input connections (polarity sensitive). To adjust high fire burner pressure, remove regulator cover from Honeywell single stage gas valve and turn regulator adjustment screw to set required burner pressure as stated in the Technical Data Table for the correct gas and model *on Page 56, Section 16.3 and Page 58, Section 16.6.*

3. To measure low fire burner pressure disconnect 10 VDC signal to modulating valve.

NOTE: Low fire burner pressure is set at factory and not field adjustable. (modulating)

NOTE: If the correct burner pressure cannot be reached, then check the inlet pressure to the valve with the burner firing. See Technical Data Table *on Page 56, Section 16.3 and Page 58, Section 16.6* for inlet pressure requirement.

Do not continue to adjust the regulator if the pressure is not changing.

If the inlet pressure is too low to allow correct burner pressure setting, then the gas inlet pressure must be corrected before completing the start-up.

11.2.2.4 Check Gas Rate (Single and Two Stage)

1. After burner pressure adjustment, allow the heater to operate for at least 15 minutes and then re-check settings. Adjust pressure setting if necessary.
2. Check gas flow rate at gas meter.
NOTE: For two stage valve (High/Low operation) check gas flow in both operating modes.
3. Turn off heater and electrical supply.
4. Remove the manometer and refit all covers to the valve and tighten the screw of the outlet pressure tap.

11.2.2.5 Check Gas Rate (Modulating)

1. After burner pressure adjustment, allow heater to operate for at least 15 minutes and then re-check settings. Adjust pressure setting if necessary.
2. Check high/low fire gas flow rate at gas meter. To place heater into high fire, disconnect modulating thermostats signal and apply 10 VDC to modulating input connections.
3. To place heater into low fire, disconnect 10 VDC from modulating input connections.
4. Turn off heater and electrical supply.
5. Remove manometer, tighten outlet pressure tap screw and replace modulating thermostat signal wires.

11.3 Pressure Switch

The pressure switch is factory pre-set for each model and is not adjustable.

11.4 Turning Off the Heater

Set the thermostat to the "OFF" position or lowest setting and the main burner will stop.

The fan(s) will continue to run until it is stopped automatically by the fan thermostat.

Do not use a disconnect switch for control of heater. Disconnect switch will turn off the fan. Heat exchanger could be damaged. Warranty will not cover damage to the heat exchanger if operated improperly. Only use the disconnect switch for turning off heater for service or during off-season.

11.5 External Controls

External controls may include time switch, interlock switch, room thermostat and frost thermostat.

Operate each control to ensure that they function correctly. Set the switches (if fitted) and thermostat(s) to the users' requirements.

11.6 Complete the Start-Up

Ensure that all covers are fitted correctly and all test points are properly sealed.





11.7 Instruction to the User

Explain the controls of the heater to the user including how to turn it on and off, using the controls equipped on site.

Give this manual to the user.

Ensure that the user is shown and understands the importance of maintaining clearances to combustibles *on Page 7, Figure 3*, installer responsibility *on Page 4, Section 2* and user instructions *on Page 35, Section 12* and all warnings defined in this manual.

SECTION 12: USER INSTRUCTIONS

⚠ DANGER		⚠ WARNING	
			
Electrical Shock Hazard Disconnect electric before service. Heater must be connected to a properly grounded electrical source.	Explosion Hazard Turn off gas supply to heater before service.	Burn Hazard Allow heater to cool before service. Tubing may still be hot after operation.	Cut/Pinch Hazard Wear protective gear during installation, operation and service. Edges are sharp.
Failure to follow these instructions can result in death, electric shock, injury or property damage.			

The UHA[T][M][X][S] Series heaters are fully automatic and operate from the external controls fitted on site.

12.1 Heater Operation

When the heater has been switched on by the thermostat installed on site, the main burner will automatically turn on.

The burner control box will control the safe ignition of the flame.

If equipped with two stage gas valve, the heater may start in low or high fire.

If equipped with a modulating gas valve, heater will start at firing rate called for by modulating thermostat. Heater will continue to run at firing rate called for by thermostat, with 10 VDC being maximum rate and 0 VDC being minimum rate. ON/OFF control is provided by thermostat R and W connections. See Page 21, Figure 10.2.

All heaters require a constant gas and electricity supply which must not be interrupted during the normal operation of this heater.

12.2 Lighting Instructions

12.2.1 To Turn On Heater

1. Ensure that the electrical and gas supplies to the heater are on. Check that the on site controls are "ON".

IMPORTANT: The thermostat setting must be above the ambient temperature for the heater to operate.

2. The automatic firing sequence will begin as described on Page 30, Figure 12. The heater will now operate automatically under the control of the on site controls.

12.2.2 To Turn Heater Off

Set the thermostat to the "OFF" position.

The burner will turn off immediately.

The fan will continue to run for 90 seconds.

To restart, turn the thermostat on or above room temperature.

12.3 Simple Troubleshooting

Some possible reasons for the heater not operating are:

1. Gas supply not "ON".
2. Electricity supply not "ON".
3. The time and/or temperature controls are not "ON".
4. A limit switch may have operated. This may be caused by an interruption of the electrical supply, failure of the distribution fan or vent or heat exchanger blockage.

If a temperature limit switch persistently trips, there is a fault which must be investigated by a contractor qualified in the installation and service of gas-fired heating equipment.

12.3.1 Simple Troubleshooting (Burner Fault)





If the burner fails to ignite for any reason, it will retry for ignition (four trials total). After four unsuccessful ignition trials, the control will put the heater into lockout for one hour.

Lockout should not occur during normal operation of the heater and indicates there is a fault condition which must be corrected. There is an LED light on the ignition control that flashes codes to assist in fault correction. See Page 36, Figure 16 for LED indication codes.

Figure 16: LED Diagnostic Codes

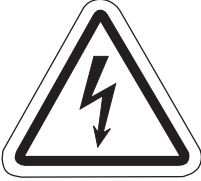
LED INDICATION	FAULT MODE
Slow Flash	Normal Operation - No call for heat.
Fast Flash	Normal Operation - Call for heat.
2 Flashes	Ignition Lockout - No flame detected.
3 Flashes	Airflow Fault - Pressure switch open or closed.
4 Flashes	Temperature Limit Switch Open
5 Flashes	Flame Sense Error - Gas valve not energized.
Steady On	Internal Control Failure

SECTION 13: SERVICING

⚠ DANGER		⚠ WARNING	
			
Electrical Shock Hazard Disconnect electric before service. Heater must be connected to a properly grounded electrical source.	Explosion Hazard Turn off gas supply to heater before service.	Burn Hazard Allow heater to cool before service. Tubing may still be hot after operation.	Cut/Pinch Hazard Wear protective gear during installation, operation and service. Edges are sharp.
Failure to follow these instructions can result in death, electric shock, injury or property damage.			

13.1 Servicing Instructions

After start-up, the heater will require maintenance to be carried out, at a minimum, annually. If the heater is used in a dirty or dusty area, more frequent maintenance may be required.

⚠ WARNING

Severe Injury Hazard Turn off gas and electrical supply before service. Fan can start automatically at any time. Failure to follow these instructions can result in severe injury or product damage.

IMPORTANT: Prior to any maintenance or service of the heater, shut off, lockout and tagout the electrical disconnect and gas valve that supplies the unit in accordance with OSHA regulations. After any maintenance or repair work, always test fire the heater in accordance with the start-up instructions on Page 29, Section 11 through Page 34, Section 11.7 to help ensure all safety systems are in working order before leaving the heater to operate. Minor faults may be traced by using the troubleshooting charts on Page 41, Section 14 through Page 45, Section 14.5.

IMPORTANT: Check all gas pipes and pipe joints to ensure there are no cracks or gas leaks. Any cracks in the pipes or pipe joints must be repaired.

IMPORTANT: Inspect all suspended components and hardware. Ensure that they are in good condition, properly tightened, and corrosion free.

13.2 Burner Maintenance**13.2.1 Burner Maintenance for Models 150-400**

1. Open the hinged door and remove from the hinges. Set door aside. See Page 47, Section 15.2.
2. Remove the filler panel (10 screws) to fully access the burner assembly. See Page 47, Section 15.2.1.
3. Remove burner assembly from cabinet via six screws. See Page 47, Section 15.2.1. Electrode and flame probe should remain attached.
4. Remove manifold from burner assembly via four screws, two on top and two on bottom. See Page 48, Section 15.2.2. Clean any deposits from the main burner which may have formed in the injectors or venturi of the burner.
5. Check condition of ignition electrode and flame probe. Clean off any deposits which may have formed, check condition of ceramic insulators. Replace as required. See Page 49, Section 15.3.

13.3 Fan/Motor Assembly Maintenance

The main fan bearings are permanently sealed and do not need lubrication. Before cleaning, turn off gas

and electrical supply. Remove the fan(s) and use a small brush or duster to clean the fan blades from each side. Replace fan when done. See *Page 53, Section 15.10*.

13.4 Heat Exchanger Maintenance

The heat exchanger will remain clean unless a problem has developed with combustion. Inspect the heat exchanger. Look for signs of overheating at the front tubes which may indicate burner over firing or persistently low air flows.

13.5 Gas Valve Maintenance

No regular maintenance is required on this device. To change gas control valves, See *Page 46, Section 15.1*.

Do not repair or disassemble gas valve.

Replace faulty gas valves with genuine replacement parts sold and supplied by Roberts-Gordon LLC.

13.6 Flue Blower

The flue blower should not require maintenance. However, if the air pressure switch is causing burner lockout, then remove the flue blower from the vent box by unscrewing the screws at the mounting plate. Screw quantity will vary by model size. Remove the screws attaching the mounting plate to the fan inlet See *Page 51, Section 15.6 through Page 52, Section 15.7*. Ensure that the fan is free to run and that the fan wheel is clean.

13.7 Venting and Air Intake Pipe

Inspect all venting and air intake pipe. Ensure that all seams are sealed and suspension points secure. Repair suspension points if any part of the venting or combustion air pipe is sagging. Check to make sure any insulation is not missing or in poor condition. Replace as necessary. Check all venting and air intake components to ensure they are in good condition, gas tight and corrosion-free.

13.8 Maintenance Checklist

Installation Code and Annual Inspections: All installations and service of ROBERTS GORDON® equipment must be performed by a contractor qualified in the installation and service equipment sold and supplied by Roberts-Gordon LLC and conform to all requirements set forth in the ROBERTS GORDON® manuals and all applicable governmental authorities pertaining to the installation, service, operation and labeling of the equipment.





To help facilitate optimum performance and safety, Roberts-Gordon LLC recommends that a qualified contractor conduct, at a minimum, annual inspections of your ROBERTS GORDON® equipment and perform service where necessary, using only replacement parts sold and supplied by Roberts-Gordon LLC.

Annual Fall Start-Up	Follow entire start-up procedure at this time and check control settings and operation.
The Vicinity of the Heater	Do not store or use flammable objects, liquids or vapors near the heater. Immediately remove these items if they are present. <i>See Page 5, Section 3.</i>
Vehicles and Other Objects	Maintain the clearances to combustibles. Do not hang anything from, or place anything on, the heater. Make sure nothing is lodged in between the heat exchanger or in the louvers. Immediately remove objects in violation of the clearances to combustibles. <i>See Page 6, Section 4.</i>

Vent Pipe/Terminals	<p>Venting must be intact. Using a flashlight, look for obstructions, cracks on the pipe, gaps in the sealed areas or corrosion.</p> <p>The area must be free of dirt and dust.</p> <p>Remove any carbon deposits or scale using a wire brush.</p> <p>If the vent terminal has a screen built in, remove any dirt, dust or deposits from the screen.</p> <p><i>See Page 10, Section 7 through Page 17, Section 8.</i></p>
Cabinet Exterior	<p>After installation, touch up scratches. Periodic paintings should be done thereafter as required. Warning labels and logo labels should be legible and accurate. Please contact Roberts-Gordon LLC or ROBERTS GORDON® independent distributor if you need replacement warning labels or logo labels.</p> <p><i>See Page 2, Figure 1 through Page 3, Figure 2.</i></p>
Combustion Air Intake Pipe	<p>Intake pipe and inlet must be intact. Look for obstructions, cracks on the pipe, gaps in the sealed areas or corrosion.</p> <p>The area must be free of dirt and dust.</p> <p>Clean and reinstall as required.</p> <p><i>See Page 17, Section 8.</i></p>
Heat Exchanger	<p>Make sure there are no cracks.</p> <p>Make sure there is no sagging, bending or distortion.</p> <p>Clean or replace as required.</p>
Gas Line and Shut-off Valves	<p>Check for gas leaks.</p> <p><i>See Page 18, Section 9.</i></p>
Burner Observation Window	<p>Make sure it is clean and free of cracks or holes.</p> <p>Clean and replace as required.</p>
Flue Blower Scroll, Wheel and Motor	<p>Compressed air or a vacuum cleaner may be used to clean dust and dirt.</p>
Inshot Burners and Orifices	<p>Clear of obstructions (even spider webs will cause problems).</p> <p>Carefully remove any dust and debris from the burner.</p>
Direct-Spark Igniter	<p>Replace if there are cracked ceramics, excessive carbon residue, or erosion of the electrode.</p> <p>The electrode gap should be 1/8" (3.2 mm).</p>
Thermostat	<p>There should be no exposed wire or damage to the device or wiring.</p> <p><i>See Page 20, Section 10.</i></p>
Suspension Points	<p>Make sure the heater is hanging securely.</p> <p>Look for signs of wear on the suspension materials or ceiling.</p> <p><i>See Page 9, Figure 4.</i></p>

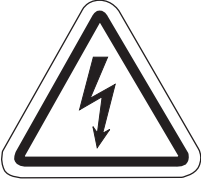
Silicone Tubing	Ensure tight, secure fit on all pressure fittings at pressure switch and vent box.
Gas Valve	Verify that cap covering pressure regulator adjustment screw is secure and has not been tampered with. Verify all wiring connections.
Condensate Drain (when installed)	Flush drain and clear any obstructions.
Wall Tag	If a wall tag is present, make sure it is legible and accurate. Please contact Roberts-Gordon LLC or your ROBERTS GORDON® independent distributor if you need a wall tag. See <i>Page 4, Section 2.1</i> .

SECTION 14: TROUBLESHOOTING

⚠ DANGER	⚠ WARNING		
			
Electrical Shock Hazard Disconnect electric before service. Heater must be connected to a properly grounded electrical source.	Explosion Hazard Turn off gas supply to heater before service.	Burn Hazard Allow heater to cool before service. Tubing may still be hot after operation.	Cut/Pinch Hazard Wear protective gear during installation, operation and service. Edges are sharp.
Failure to follow these instructions can result in death, electric shock, injury or property damage.			

14.1 General

START

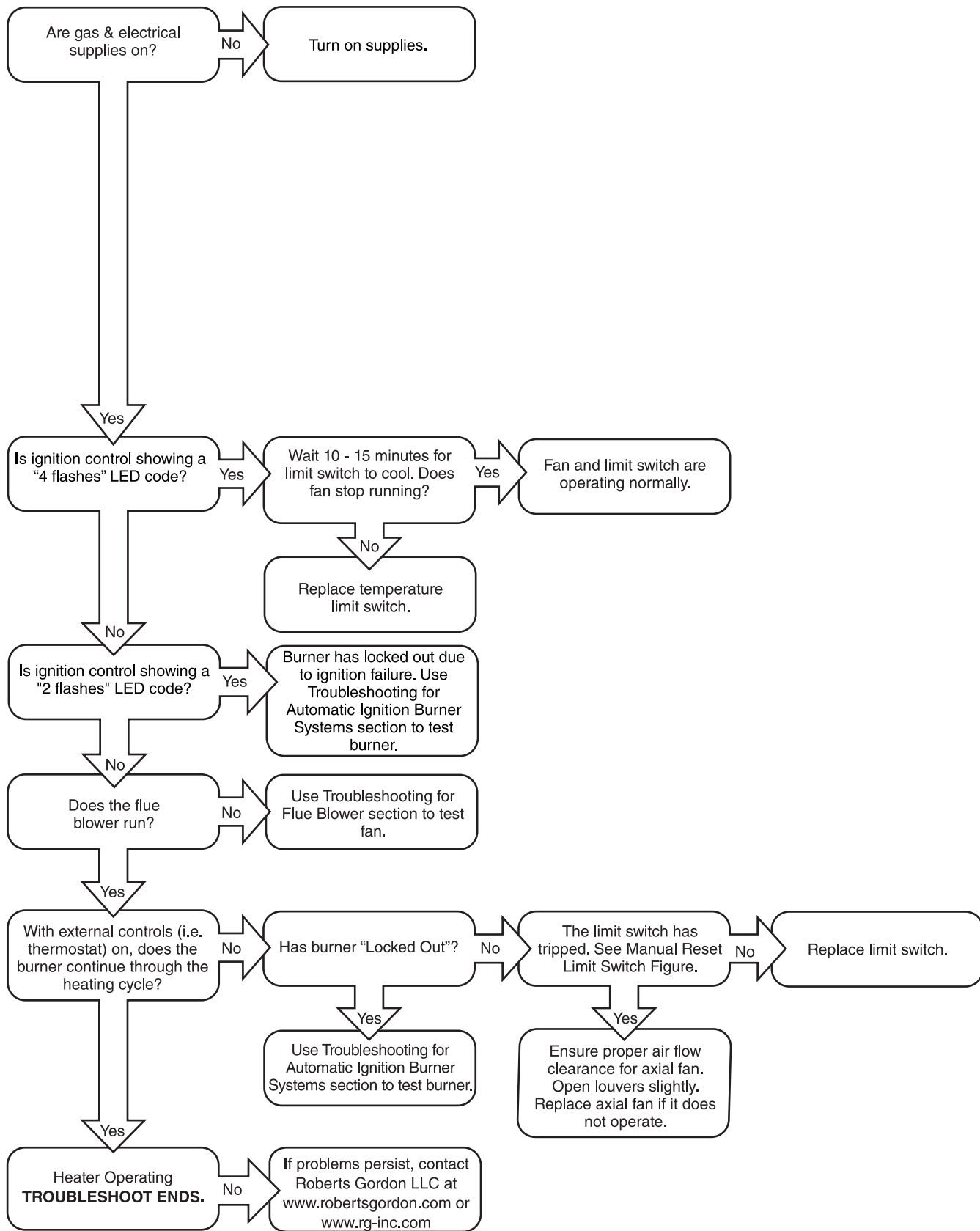

14.2 Troubleshooting For Automatic Ignition Burner Systems

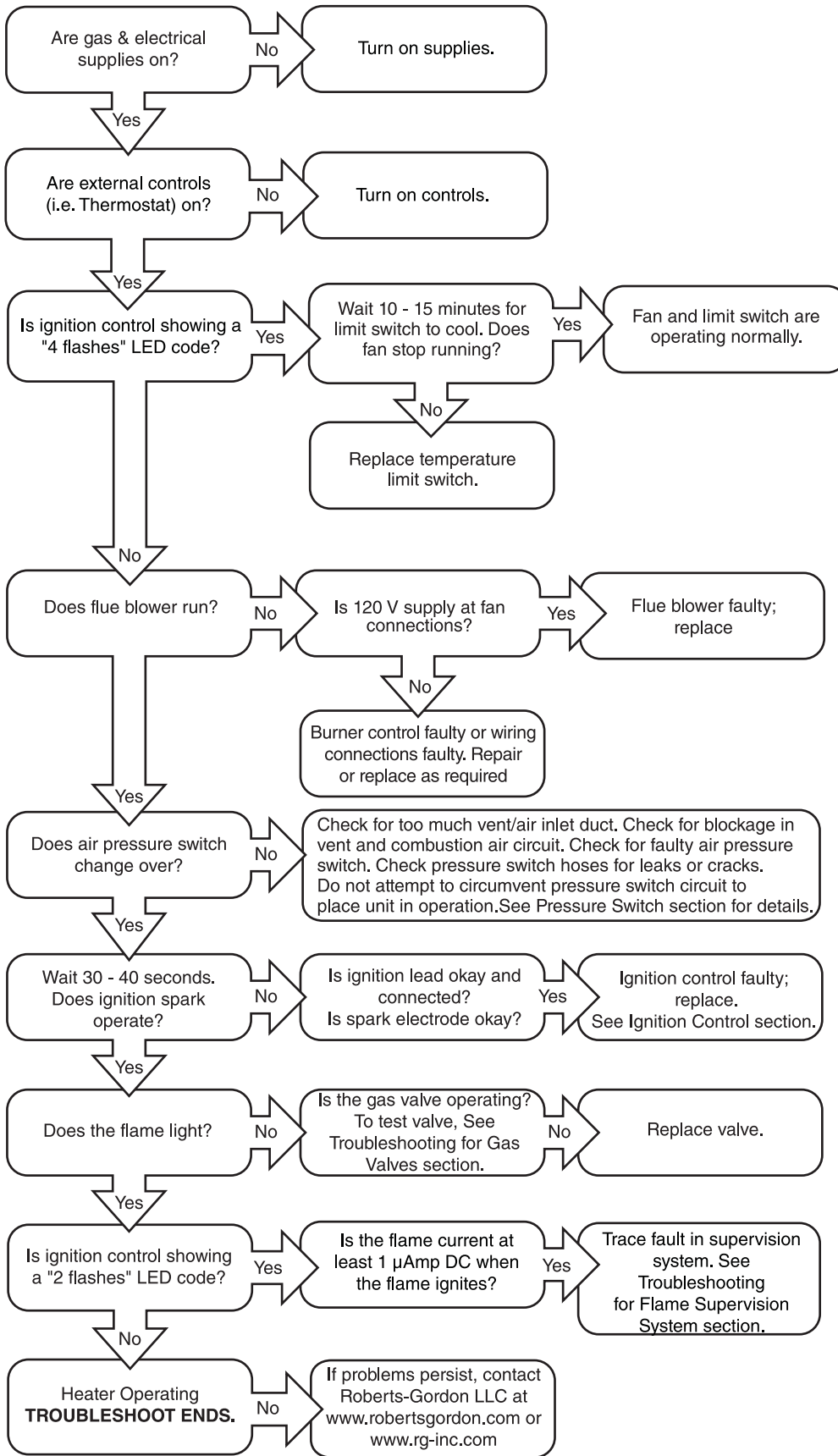

For your safety and optimum heater performance, use only replacement parts sold and supplied by Roberts-Gordon LLC.

Conduct start-up procedure as shown on Page 29, Section 11.

14.3 Troubleshooting for Flame Supervision System

To measure flame current, connect a 0 - 50 μ A DC meter in series with the flame probe. If the meter reads negative values, then reverse the test leads.

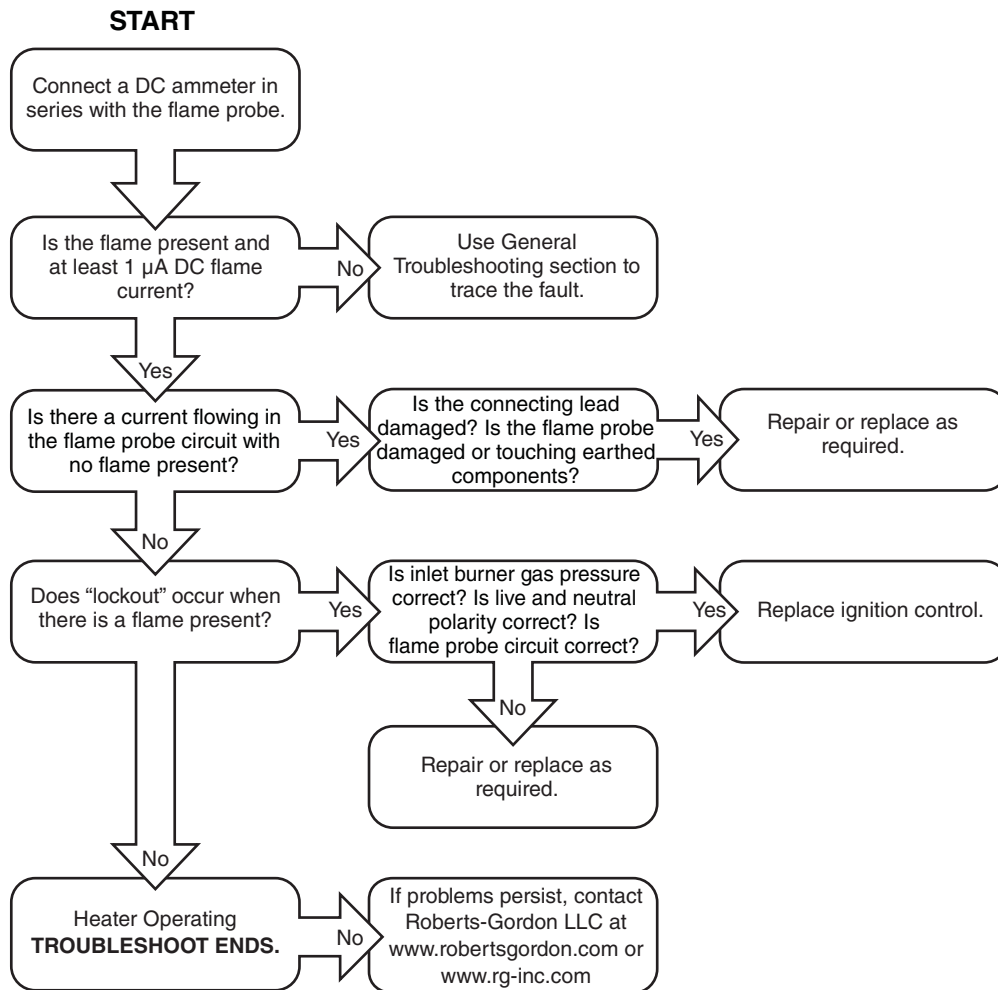

NOTE: Minimum flame probe current 1 μ A DC. Typical flame probe current 3-5 μ A DC.

14.4 Troubleshooting for Gas Valves

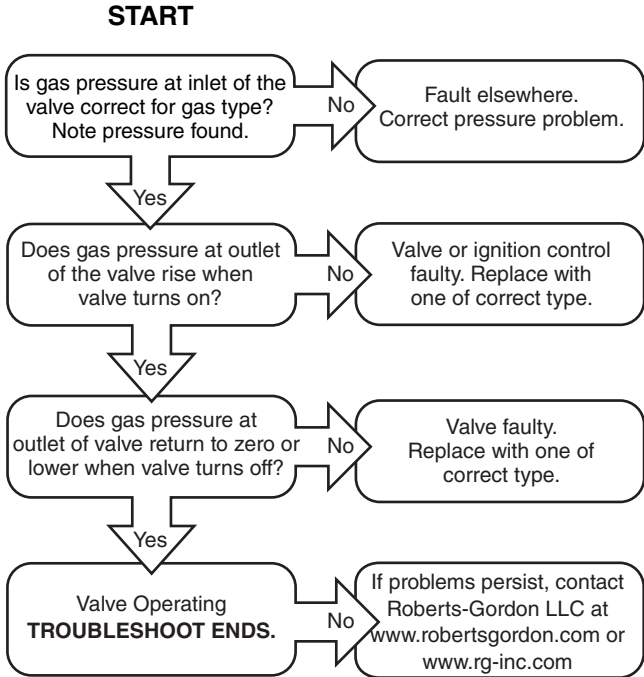



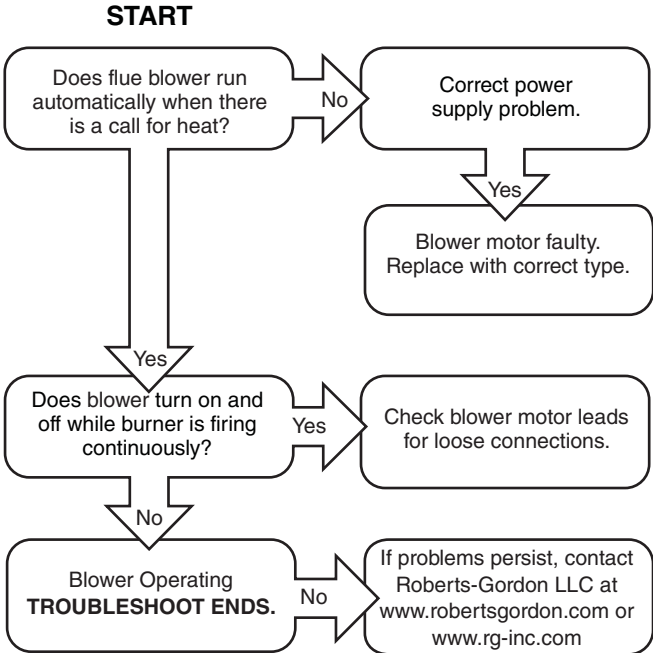

14.5 Troubleshooting for Flue Blower

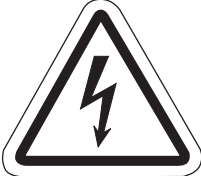

For your safety and optimum heater performance, use only genuine replacement parts sold and supplied by Roberts-Gordon LLC.

Conduct start-up procedure as shown on Page 29, Section 11.

SECTION 15: REPLACEMENT PARTS

⚠ DANGER	⚠ WARNING		
			
Electrical Shock Hazard	Explosion Hazard	Fire Hazard	Carbon Monoxide Hazard
Use only genuine ROBERTS GORDON® replacement parts per this installation, operation and service manual.			
Failure to follow these instructions can result in death, electric shock, injury or property damage.			

See warnings and important information on *Page 37, Section 13* before removing or replacing parts.

Burner Components

All serviceable burner parts are accessed by the hinged door on the side of the heater.

15.1 Gas Valve

Remove the gas supply pipe at the heater inlet. Follow instructions on *Page 47, Section 15.2* through *Page 49, Section 15.3* to remove gas valve/manifold.

Replace in reverse order. Verify that the gas flow direction of the valve is correct. Use a minimum amount of gas seal on the thread joint. Check that all the joints are leak free. Reset gas valve. See *Page 33, Section 11.2.2*.

IT IS IMPORTANT THAT ONLY THE CORRECT GAS VALVE IS USED WHEN REPLACING THESE CONTROLS.

Description	Part Number
Single Stage Gas Valve, NG (Models UHA[X][S] 150 - 250)	90032505
Single Stage Gas Valve, LP (Models UHA[X][S] 150 - 250)	90032506
Single Stage Gas Valve, NG (Models UHA[X][S] 300 - 400)	90032520
Single Stage Gas Valve, LP (Models UHA[X][S] 300 - 400)	90032521
Two Stage Gas Valve, NG (Models UHA[T][X][S] 150 - 250)	90032530
Two Stage Gas Valve, LP (Models UHA[T][X][S] 150 - 250)	90032531
Two Stage Gas Valve, NG (Models UHA[T][X][S] 300 - 400)	90032532
Two Stage Gas Valve, LP (Models UHA[T][X][S] 300 - 400)	90032533
Exa Valve ½" (Models UHA[M][X][S] 150-250) NG and LP	90032550
Exa Valve ¾" (Models UHA[M][X][S] 300-400) NG and LP	90032551

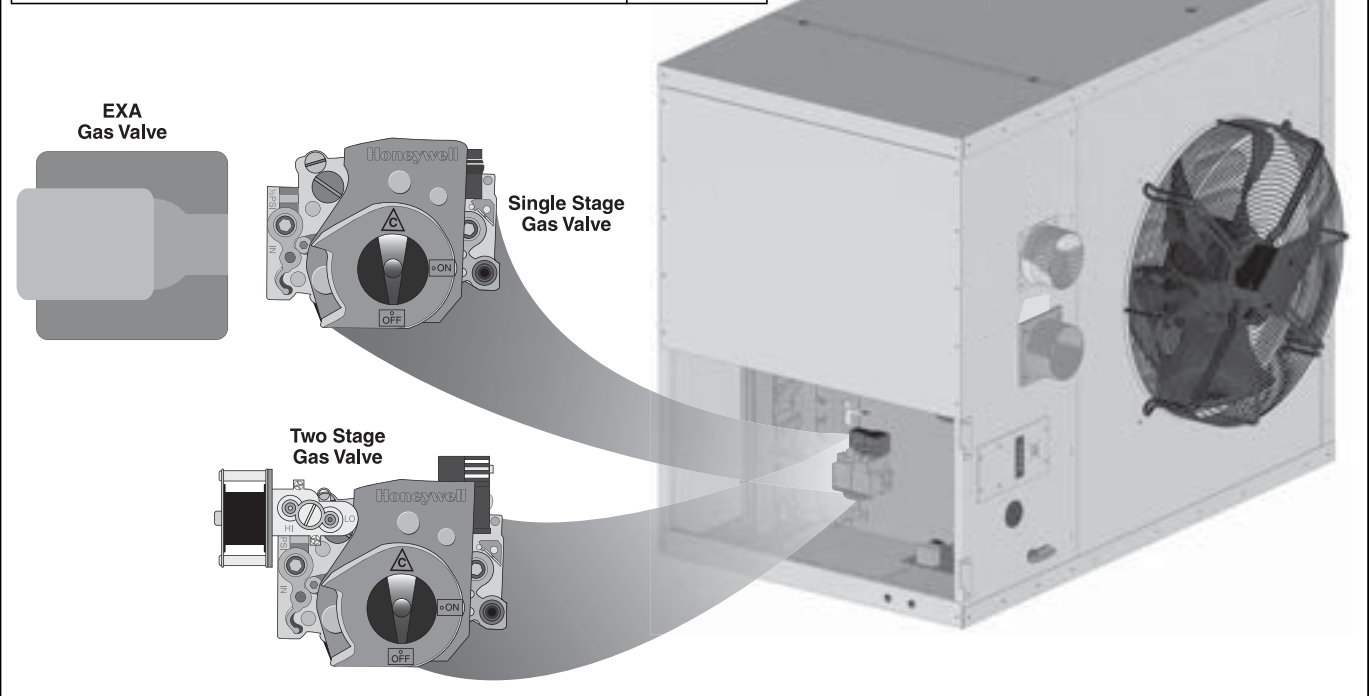

15.2 Burner Compartment for Models UHA[T][M][X][S] 150-400

Side View of Burner Compartment with Hinged Door Removed

Before burner removal, remove the 10 screws holding the filler panel on and remove the filler panel.

NOTE: Models UHA 300-400 have two axial fans.

Filler Panel

Burner Assembly

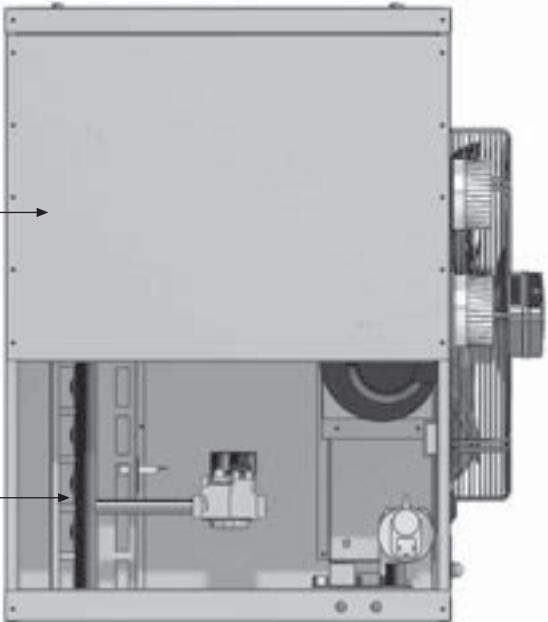

15.2.1 Burner Compartment without Filler Panel for Models UHA[T][M][X][S] 150-400

Side View of Burner Compartment with Filler Panel Removed

Burner assembly must be removed to service orifices, manifold or burners. Following any work, refit components in reverse order.

NOTE: Models UHA 300-400 have two axial fans.

Screws
Flame Probe
Ignition Electrode
Manifold
Screws
Screws
Orifice
Inshot Burners

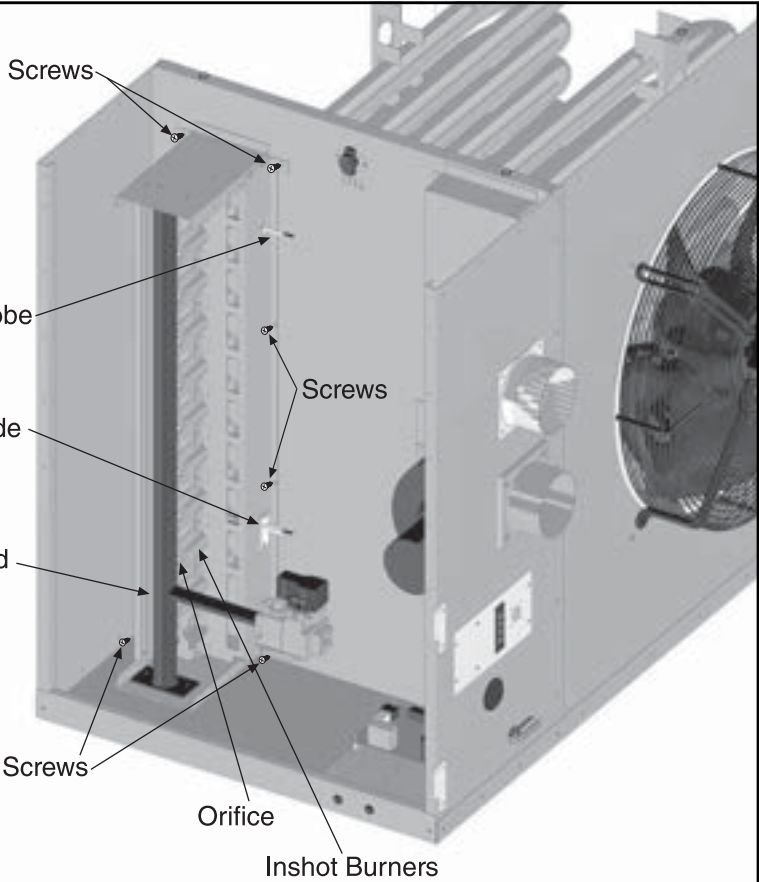

15.2.2 Burner Injectors for Models UHA[T][M][X][S] 150-400

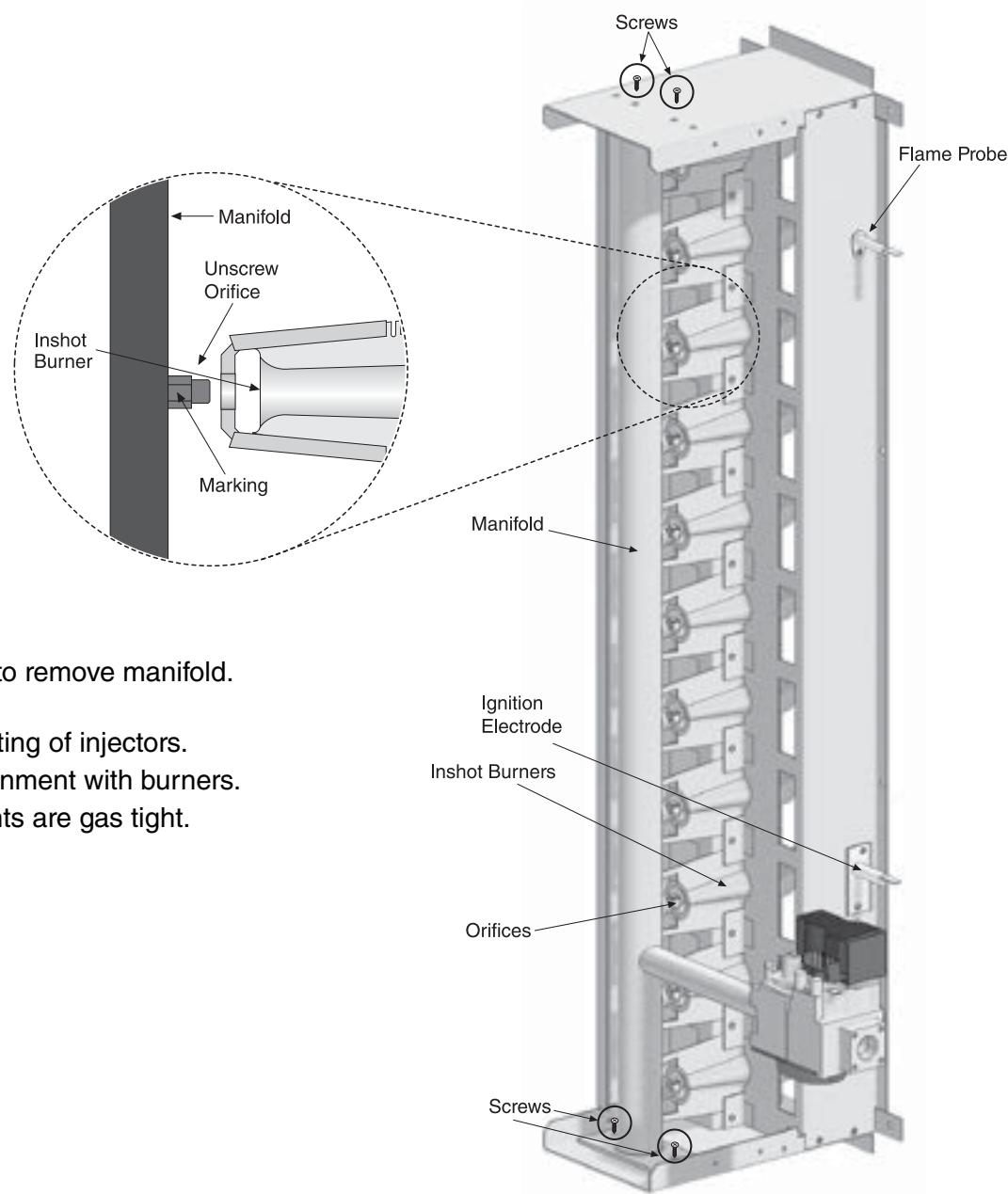

Remove 4 screws to remove manifold.

- Ensure gas tight fitting of injectors.
- Ensure correct alignment with burners.
- Ensure all pipe joints are gas tight.

MODEL	UHA [T][M][X][S] 150	UHA [T][M][X][S] 175	UHA [T][M][X][S] 200	UHA [T][M][X][S] 225	UHA [T][M][X][S] 250	UHA [T][M][X][S] 300	UHA [T][M][X][S] 350	UHA [T][M][X][S] 400
Orifice Quantity	7	8	9	10	11	12	14	14
Natural Gas								
Orifice Marking	43	43	2.25 mm	2.25 mm	2.25 mm	43	43	40
P/N	91930043	91930043	91930225	91930225	91930225	91930043	91930043	91930040
Propane								
Orifice Marking	1.35 mm	1.35 mm	54	54	54	1.45 mm	53	53
P/N	91930135	91930135	91930054	91930054	91930054	91930145	91930053	91930053

15.3 Ignition Electrode and Flame Probe for Models UHA[T][M][X][S] 150-400

To replace the ignition electrode or flame probe, remove the electrical lead and screw. Pull out from mounting. Refit in reverse ensuring that the gap to burner is as shown in the front view of the burner compartment.

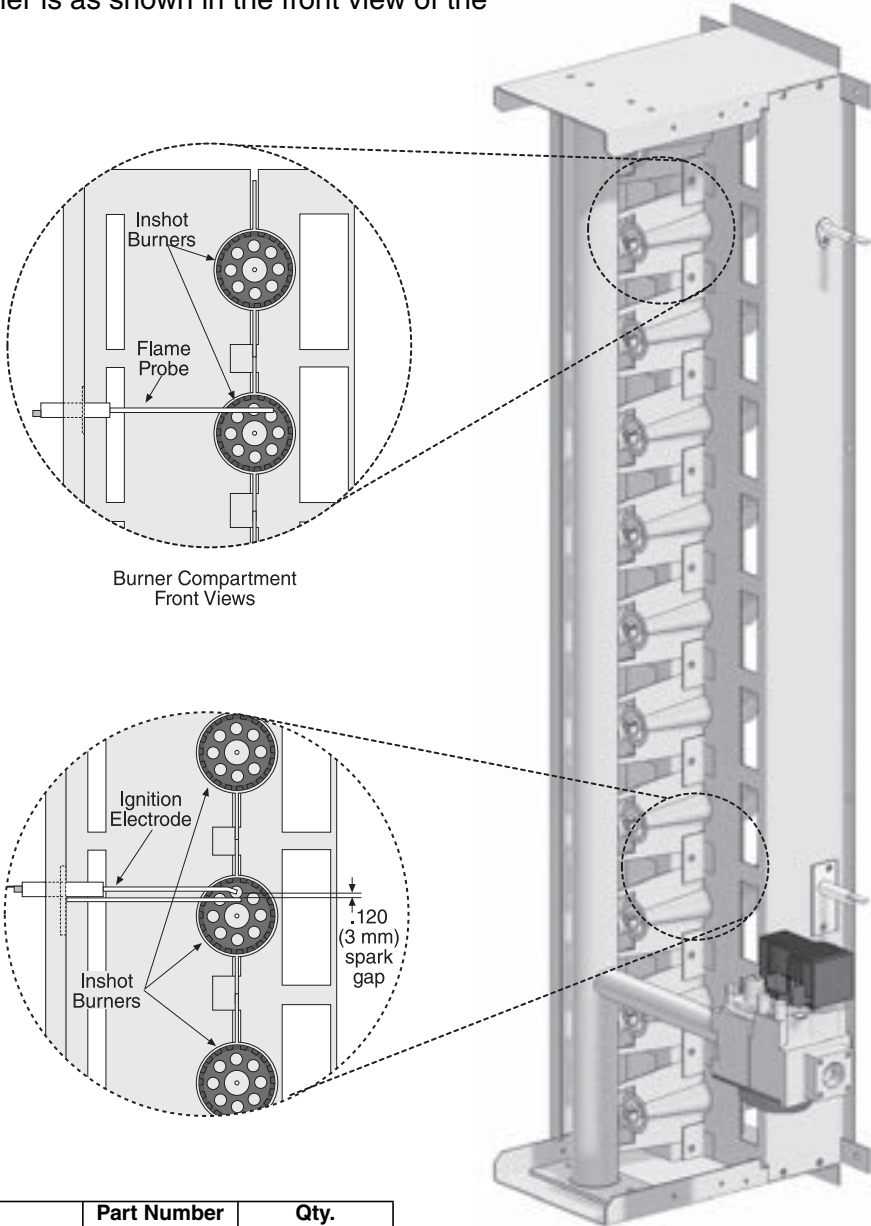

Description	Part Number	Qty.
Spark Electrode	90427411	1
Automatic Ignition Flame Probe	90439300	1
Transformer	90436900K	1
Ignition Module	90434008	1
Inshot Burners UHA[T][M][X][S] 150	92000001	7
Inshot Burners UHA[T][M][X][S] 175	92000001	8
Inshot Burners UHA[T][M][X][S] 200	92000000	9
Inshot Burners UHA[T][M][X][S] 225	92000000	10
Inshot Burners UHA[T][M][X][S] 250	92000000	11
Inshot Burners UHA[T][M][X][S] 300	92000000	12
Inshot Burners UHA[T][M][X][S] 350	92000000	14
Inshot Burners UHA[T][M][X][S] 400	92000000	14
Limit Switch (150 - 400) [300 - 400 LOWER]	90412103	1
Limit Switch (300 - 400) [UPPER]	90412105	1

15.4 Heat Exchanger

The heat exchanger consists of a four-pass design with 1.75" outer diameter [aluminized steel] [409 stainless steel] tube. The tube plates are made of [aluminized steel] [409 stainless steel]. The tube supports are made of [aluminized steel] [409 stainless steel].

15.5 Louvers and Louver Spring

Horizontal Louvers

Description	UHA[T][M][X][S] 150 - 175	UHA[T][M][X][S] 200 - 250	UHA[T][M][X][S] 300 - 400
Horizontal Louvers P/N	11011847	11011847	11011846
Spring P/N	91901200	91901200	91901200
Quantity	7	9	11

The louvers for standard range models UHA[T][M][X][S]150 - UHA[T][M][X][S]400 are only available in horizontal configurations.

15.6 Flue Blower for Models UHA[T][M][X][S] 150-300

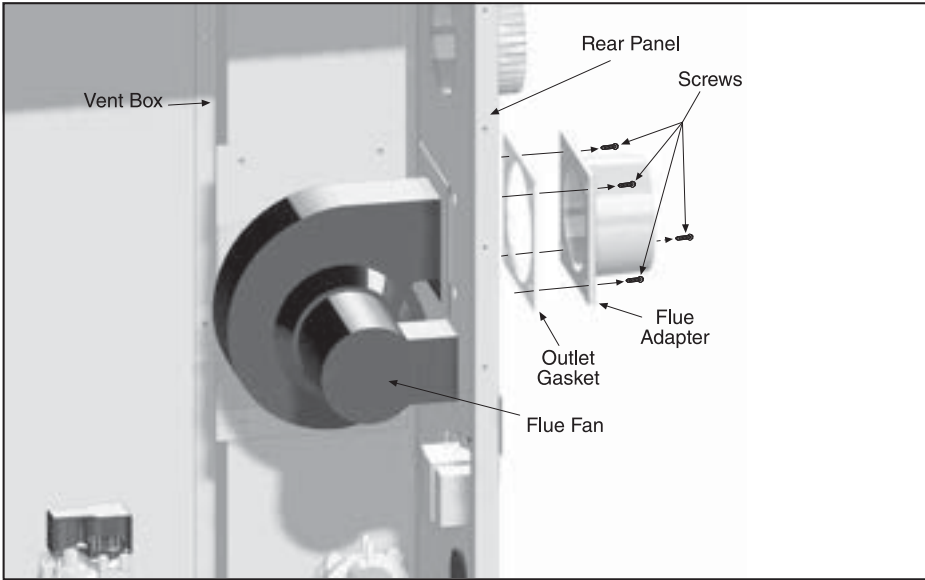

Remove screws securing outlet flange to the flue adapter.

Refit in reverse order.

Disconnect electrical connections at plug in tabs.

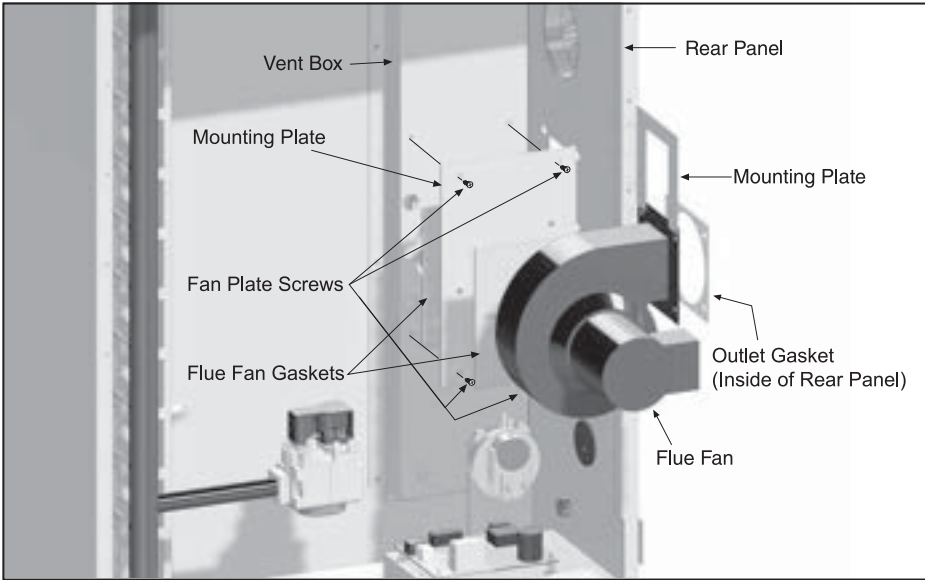

Remove screws securing flue fan mounting plate to vent box.

Remove screws securing mounting plate to fan. (Not shown)

Refit in reverse.

Use new gaskets.

Ensure sealed joints.

Ensure mounting plate orifice is clear and not obstructed.

MODEL	UHA[T][M][X][S] 150 - 300
Flue Blower P/N	90710403

IT IS IMPORTANT THAT ONLY THE CORRECT FLUE BLOWER SPECIFIED FOR EACH MODEL TYPE IS USED WHEN REPLACING THESE ITEMS.

Carry out a start-up after working on or changing an flue blower. See Page 29, Section 11.

15.7 Flue Blower for Models UHA[T][M][X][S] 350-400

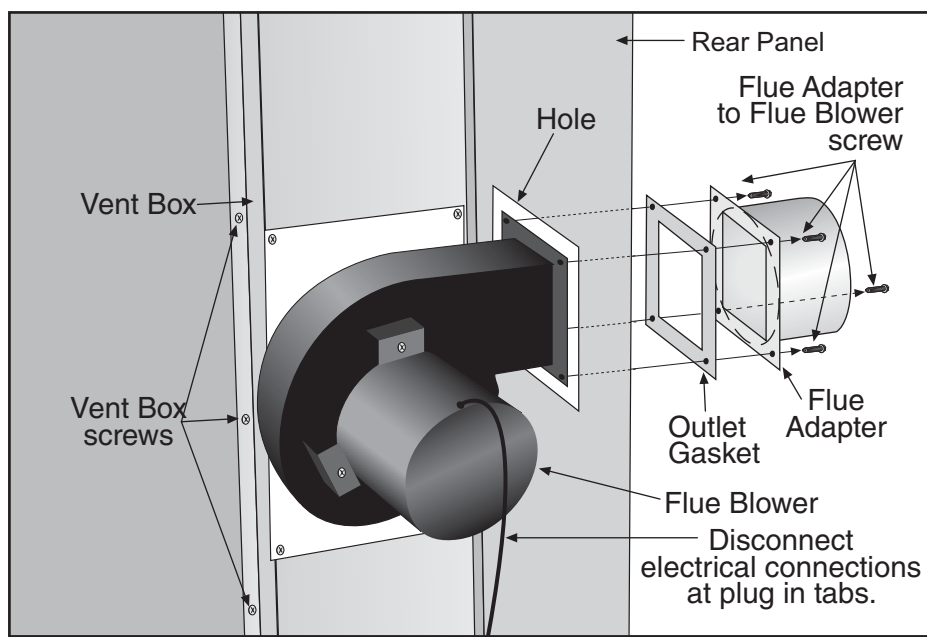

Remove screws securing outlet flange to the flue adapter.

Refit in reverse order.

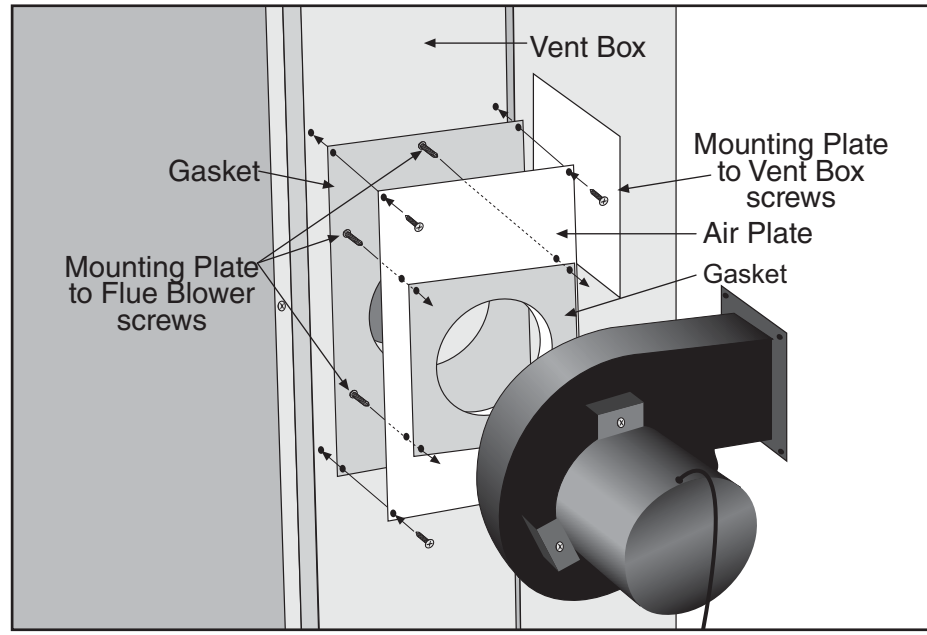

Remove screws securing flue blower mounting plate to vent box.

Remove screws securing mounting plate to blower.

Refit in reverse.

Use new gaskets.

Ensure sealed joints.

Ensure mounting plate orifice is clear and not obstructed.

MODEL	UHA[T][M][X][S] 350 - 400
Flue Blower P/N	90710402

IT IS IMPORTANT THAT ONLY THE CORRECT FLUE BLOWER SPECIFIED FOR EACH MODEL TYPE IS USED WHEN REPLACING THESE ITEMS.

Carry out a start-up after working on or changing an flue blower. See Page 29, Section 11.

15.8 Pressure Switch

⚠ WARNING



Carbon Monoxide Hazard

Use correct pressure switch specified for each model.

Use of incorrect pressure switch or disabling pressure switch circuit could cause unsafe condition.

Failure to follow these instructions can result in death or serious injury.

Pull off 3 way connector. Spring open plastic clips of mounting cradle. Replace with correct type of pressure switch for model. The pressure switches are color coded for each pressure setting. Carry out a start-up after working on or changing a pressure switch. See *Page 29, Section 11*.

MODEL	UHA [T][M][X][S] 150 - 175	UHA [T][M][X][S] 200 - 225	UHA [T][M][X][S] 250	UHA [T][M][X][S] 300	UHA [T][M][X][S] 350	UHA [T][M][X][S] 400
Pressure Switch Kit P/N	90439803	90439808	90439812	90439811	90439805	90439811
Color Code	grey	orange	orange	grey	blue	grey
Set Point in. w.c.	0.41	0.79	0.18	0.72	0.55	0.72
Pressure Switch Snap Ring P/N	90439850	90439850	90439850	90439850	90439850	90439850

15.9 Ignition Control

The control mounts to the electrical plate. Pull out ignition cable and wiring from board, noting their positions. Release the four mounting standoffs. Refit in reverse. Ensure correct location of ignition cable and all other wiring.

15.10 Axial Fan/Guard/Motor Assembly

The axial fan unit for the heater is supplied completely assembled and balanced

MODEL	UHA[T][M][X][S] 150 - 175	UHA[T][M][X][S] 200- 250	UHA[T][M][X][S] 300 - 400
Axial Fan Guard	91901104	91901104	91901105
Axial Fan Motor	90600107	90600107	90600106
Axial Fan Blade	90709006	90709006	90709005

15.10.1 Fan Removal and Replacement

⚠ **WARNING**



Severe Injury Hazard

Turn off gas and electrical supply before service.

Fan can start automatically at any time.

Failure to follow these instructions can result in severe injury or product damage.

15.11 Limit Switches

15.11.1 Removal and Replacement

1. Remove the electrical connections to the switch.
2. Unscrew the two screws securing the switch.
3. Fit a new switch with two screws.
4. Reconnect the electrical connections and test operation.

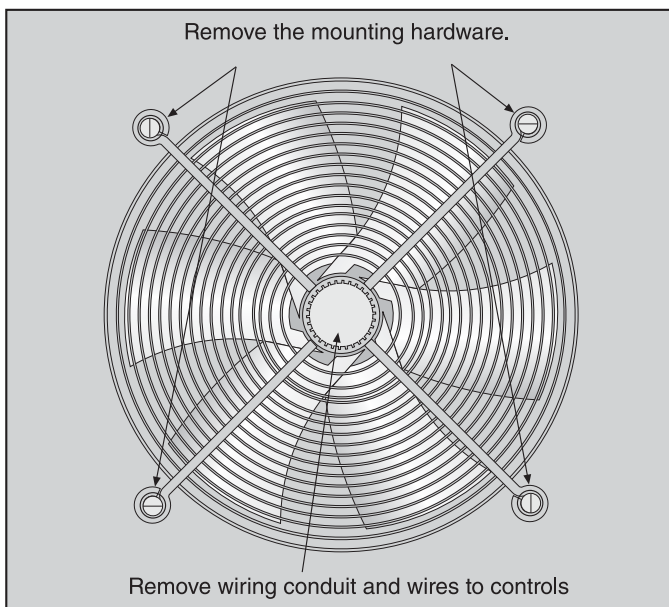

Description	Part Number	Qty.
Axial Fan UHA[T][M][X][S] 150 - 175	90710417	1
Axial Fan UHA[T][M][X][S] 200 - 250	90710417	1
Axial Fan UHA[T][M][X][S] 300 - 400	90710416	2

15.10.2 To Replace the Fan Assembly

To replace the fan assembly, reverse the procedure shown above.

- Check that the fan blades are free to rotate before turning on the power to the fan.
- Strictly comply with the color code of the fan wires to ensure correct operation. See Page 22, Section 10.3, Page 24, Section 10.5 or Page 26, Section 10.7 wiring diagram.
- Use only genuine replacement parts sold and supplied by Roberts-Gordon LLC.

SECTION 16: SPECIFICATIONS

16.1 Dimension Data for Models UHA[T][M][X][S] 150-250

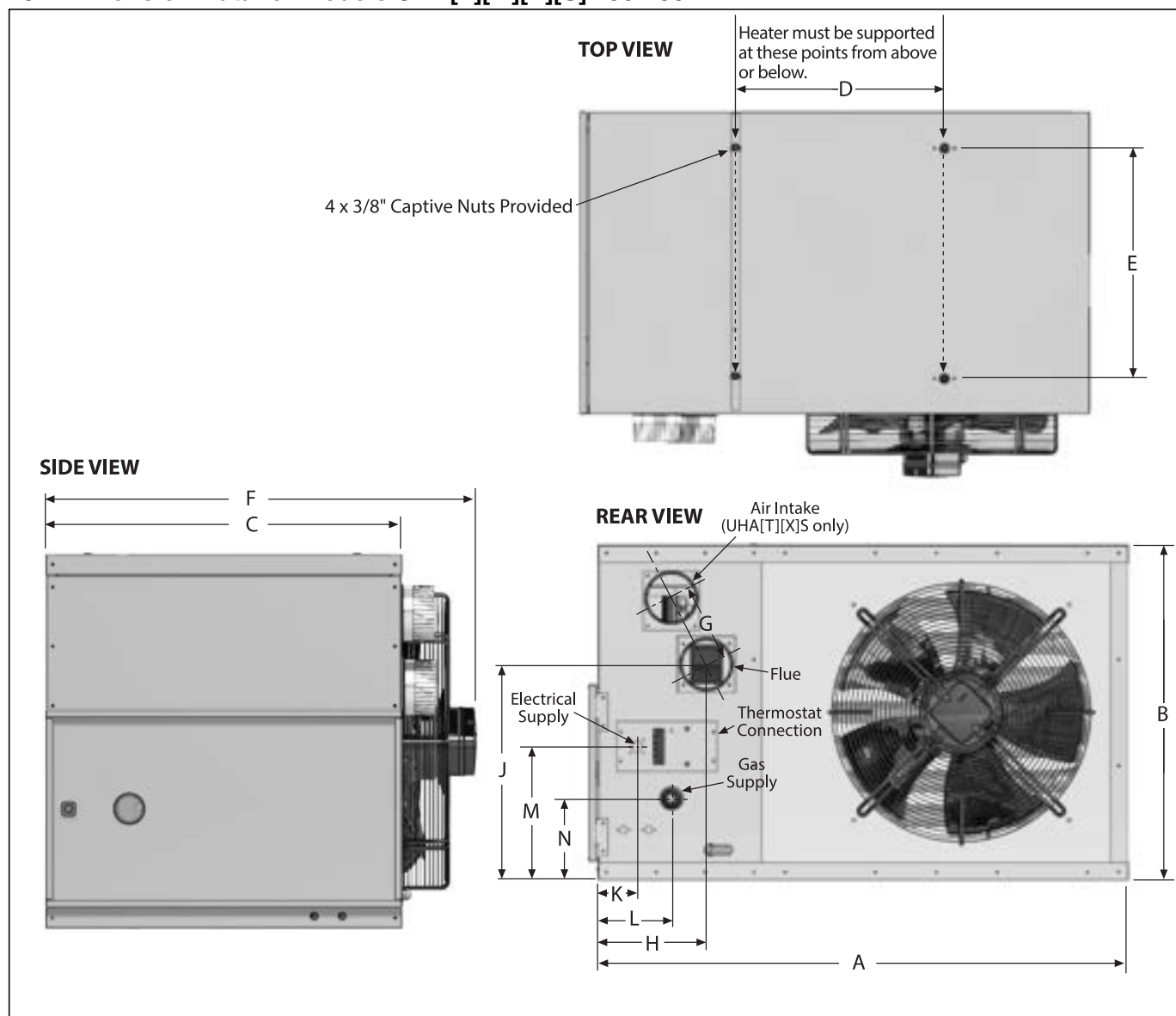

Model	UHA[T][M][X][S]150	UHA[T][M][X][S]175	UHA[T][M][X][S]200	UHA[T][M][X][S]225	UHA[T][M][X][S]250
A	in (cm)	42.4 (107.7)	42.4 (107.7)	42.4 (107.7)	42.4 (107.7)
B	in (cm)	26.7 (67.8)	26.7 (67.8)	35.0 (88.9)	35.0 (88.9)
C	in (cm)	25.5 (64.8)	25.5 (64.8)	25.5 (64.8)	25.5 (64.8)
D	in (cm)	17.6 (44.7)	17.6 (44.7)	17.6 (44.7)	17.6 (44.7)
E	in (cm)	19.4 (49.3)	19.4 (49.3)	19.4 (49.3)	19.4 (49.3)
F	in (cm)	30.0 (76.2)	30.0 (76.2)	32.0 (81.3)	32.0 (81.3)
G	in (cm)	6.0 (15.2)	6.0 (15.2)	6.6 (16.8)	6.6 (16.8)
H	in (cm)	8.7 (22.1)	8.7 (22.1)	8.6 (22)	8.6 (22)
J	in (cm)	17.2 (43.7)	17.2 (43.7)	17.7 (45)	17.7 (45)
K	in (cm)	3.1 (7.9)	3.1 (7.9)	8.1 (20.6)	8.1 (20.6)
L	in (cm)	5.9 (15)	5.9 (15)	5.7 (14.5)	5.7 (14.5)
M	in (cm)	10.7 (27.2)	10.7 (27.2)	10.5 (26.7)	10.5 (26.7)
N	in (cm)	6.5 (16.5)	6.5 (16.5)	6.5 (16.5)	6.5 (16.5)

16.2 General Technical Data Table

	Model	UHA[T][M][X][S] 150	UHA[T][M][X][S] 175	UHA[T][M][X][S] 200	UHA[T][M][X][S] 225	UHA[T][M][X][S] 250
Full Load Amps @ 120 V	A	10.6	10.6	10.6	10.6	10.6
Air Volume	CFM	3500	3500	3716	3716	3716
Flue and Air Intake						
Flue Intake Size	in (cm)	4 (10)	4 (10)	4 (10)	4 (10)	4 (10)
Air Intake Size	in (cm)	4 (10)	4 (10)	4 (10)	4 (10)	4 (10)
*Maximum Straight Flue/Air Intake	ft (m)	40 (1)	40 (1)	40 (1)	40 (1)	40 (1)
Weight (Net)	lbs (kg)	217 (98.4)	237 (107.5)	255 (115.7)	265 (120.2)	270 (122.5)

*Do not exceed the maximum length of flue stated or heater may not operate properly.

16.3 Technical Data Table

	Model	UHA[T][M][X][S] 150	UHA[T][M][X][S] 175	UHA[T][M][X][S] 200	UHA[T][M][X][S] 225	UHA[T][M][X][S] 250
Total Input High Fire	(Btu/h) x (1000)	150	175	200	225	250
Total Input Low Fire	(Btu/h) x (1000)	105	122.5	140	157.5	175
Total Output High Fire	(Btu/h) x (1000)	123	143.5	164	184.5	205
Total Output Low Fire	(Btu/h) x (1000)	86	100	115	129	143.5
Efficiency (Max Input)	%	82	82	82	82	82
Natural Gas Data - Inlet Pressure 5.0 in wc Min., 14 in wc Max.						
Burner Pressure High Fire	in wc	3.0	3.0	3.2	3.4	3.45
Burner Pressure Low Fire	in wc	1.3	1.3	1.6	1.7	1.7
LPG / Propane Data - Inlet Pressure 12.0 in wc Min., 14 in wc Max.						
Burner Pressure High Fire	in wc	11.1	11.2	9.5	11.1	11.6
Burner Pressure Low Fire	in wc	5.0	5.5	4.7	5.4	5.5

16.4 Dimension Data for Models UHA[T][M][X][S] 300-400

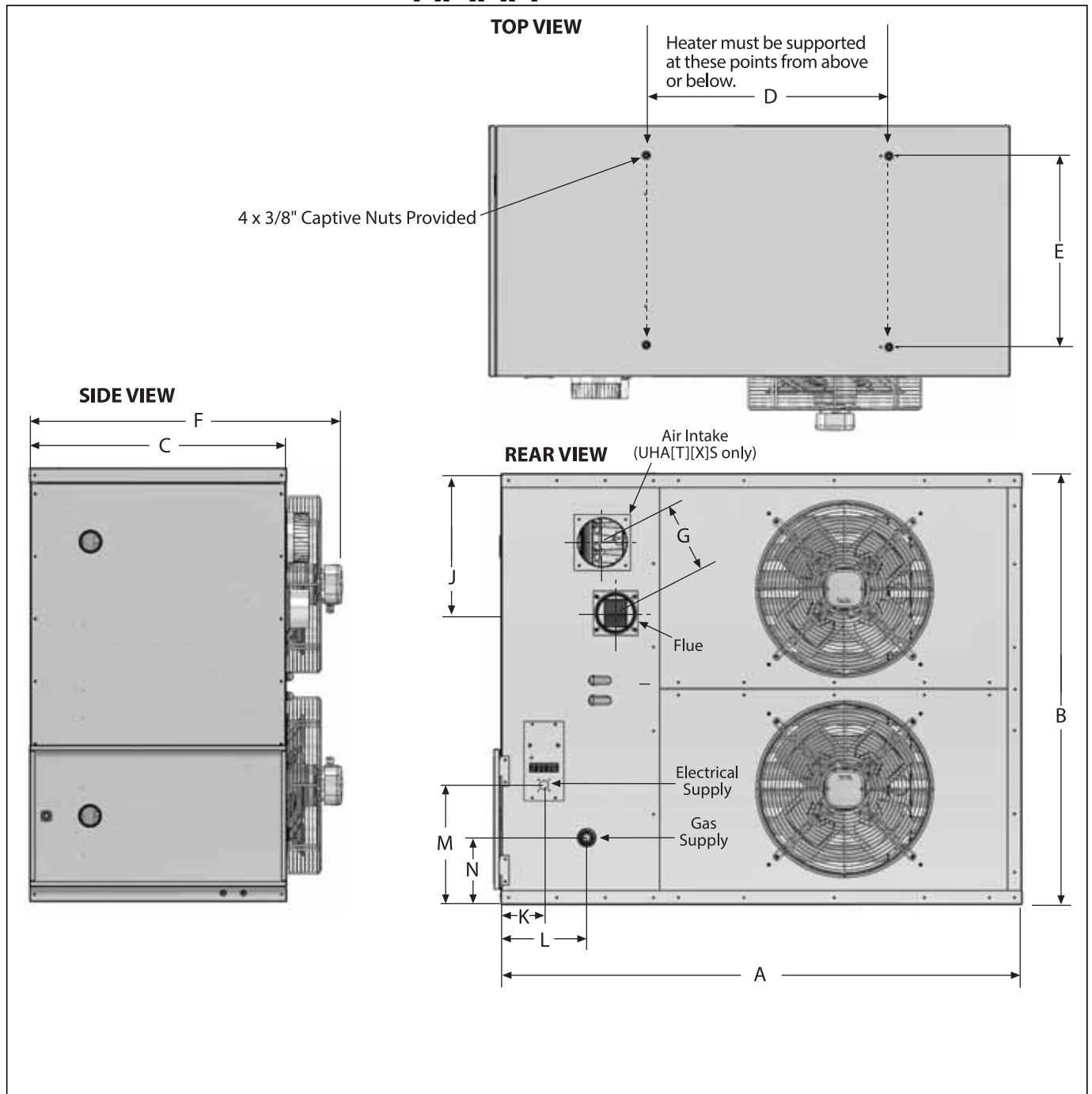

Model		UHA[T][M][X][S]300	UHA[T][M][X][S]350	UHA[T][M][X][S]400
A	in (cm)	52.3 (132.8)	52.3 (132.8)	52.3 (132.8)
B	in (cm)	43.2 (109.7)	43.2 (109.7)	43.2 (109.7)
C	in (cm)	25.5 (64.8)	25.5 (64.8)	25.5 (64.8)
D	in (cm)	24.7 (62.7)	24.7 (62.7)	24.7 (62.7)
E	in (cm)	19.4 (49.3)	19.4 (49.3)	19.4 (49.3)
F	in (cm)	30.0 (76.2)	30.0 (76.2)	30.0 (76.2)
G	in (cm)	7.0 (17.8)	7.0 (17.8)	7.0 (17.8)
H	in (cm)	11.2 (28.4)	11.2 (28.4)	11.2 (28.4)
J	in (cm)	13.8 (35.1)	13.8 (35.1)	13.8 (35.1)
K	in (cm)	4.3 (6.8)	4.3 (6.8)	4.3 (6.8)
L	in (cm)	8.7 (22.1)	8.7 (22.1)	8.7 (22.1)
M	in (cm)	12.1 (30.7)	12.1 (30.7)	12.1 (30.7)
N	in (cm)	6.5 (16.5)	6.5 (16.5)	6.5 (16.5)

16.5 General Technical Data Table

	Model	UHA[T][M][X][S]300	UHA[T][M][X][S]350	UHA[T][M][X][S]400
Full Load Amps @ 120 V	A	11.6	11.6	11.6
Air Volume	CFM	4663	4663	4663
Flue and Air Intake				
Flue Intake Size	in (cm)	4 (10)	4 (10)	4 (10)
Air Intake Size	in (cm)	5 (13)	5 (13)	5 (13)
*Maximum Straight Flue/Air Intake	ft (m)	40 (1)	40 (1)	40 (1)
Weight (Net)	lbs (kg)	355 (161.0)	375 (170.1)	375 (170.1)

*Do not exceed the maximum length of flue stated or heater may not operate properly.

16.6 Technical Data Table

	Model	UHA[T][M][X][S]300	UHA[T][M][X][S]350	UHA[T][M][X][S]400
Total Input High Fire	(Btu/h) x (1000)	300	350	385
Total Input Low Fire	(Btu/h) x (1000)	210	245	269.5
Total Output High Fire	(Btu/h) x (1000)	246	287	315.7
Total Output Low Fire	(Btu/h) x (1000)	172.2	200.9	221
Efficiency	%	82	82	82
Natural Gas Data - Inlet Pressure 5.0 in wc Min., 14 in wc Max.				
Burner Pressure High Fire	in wc	3.9	4.0	3.3
Burner Pressure Low Fire	in wc	1.8	1.8	1.4
LPG / Propane Data - Inlet Pressure 12.0 in wc Min., 14 in wc Max.				
Burner Pressure High Fire	in wc	10.0	8.7	10.7
Burner Pressure Low Fire	in wc	4.9	4.2	5.1

SECTION 17: THE ROBERTS GORDON® UHA-SERIES WARRANTY**ROBERTS-GORDON LLC WILL PAY FOR:**

Within 24 months from date of purchase by buyer or 27 months from date of shipment by Roberts-Gordon LLC (whichever comes first), replacement parts will be provided free of charge for any part of the product which fails due to a manufacturing or material defect.

Roberts-Gordon LLC will require the part in question to be returned to the factory. Roberts-Gordon LLC will, at its sole discretion, repair or replace after determining the nature of the defect and disposition of part in question.

ROBERTS GORDON® Replacement Parts are warranted for a period of 18 months from date of shipment from Roberts-Gordon LLC or the remaining ROBERTS GORDON® UHA-Series warranty.

ROBERTS-GORDON LLC WILL NOT PAY FOR:

Service trips, service calls and labor charges.

Shipment of replacement parts.

Claims where the total price of the goods have not been paid.

Damage due to:

- Improper installation, operation or maintenance.
- Misuse, abuse, neglect, or modification of the ROBERTS GORDON® UHA-Series in any way.
- Use of the ROBERTS GORDON® UHA-Series for other than its intended purpose.
- Incorrect gas or electrical supply, accident, fire, floods, acts of God, war, terrorism, or other casualty.
- Improper service, use of replacement parts or accessories not specified by Roberts-Gordon LLC.
- Failure to install or maintain the ROBERTS GORDON® UHA-Series as directed in the Installation, Operation and Service manual.
- Relocation of the ROBERTS GORDON® UHA-Series after initial installation
- The use of the ROBERTS GORDON® UHA-Series in a corrosive atmosphere containing contaminants.
- The use of the ROBERTS GORDON® UHA-Series in the vicinity of a combustible or explosive material.
- Any defect in the ROBERTS GORDON® UHA-Series arising from a drawing, design, or specification supplied by or on behalf of the consumer.
- Damage incurred during shipment. Claim must be filed with carrier.

WARRANTY IS VOID IF:

The ROBERTS GORDON® UHA-Series is not installed by an electrician qualified in the installation and service of control systems for heating equipment.

You cannot prove original purchase date and required annual maintenance history.

The data plate and/or serial number are removed, defaced, modified or altered in any way.

The ownership of the ROBERTS GORDON® UHA-Series is moved or transferred. This warranty is nontransferable. Roberts-Gordon LLC is not permitted to inspect the damaged controller and/or component parts.

READ YOUR INSTALLATION, OPERATION AND SERVICE MANUAL

If you have questions about your controller, contact your installing professional. Should you need Replacement Parts or have additional questions, call or write:

Roberts-Gordon LLC

1250 William Street

P.O. Box 44

Buffalo, New York 14240-0044

Telephone: +1.716.852.4400

Fax: +1.716.852.0854

Toll Free: 800.828.7450

www.robertsgordon.com

www.rg-inc.com

Roberts-Gordon LLC's liability, and your exclusive remedy, under this warranty or any implied warranty (including the implied warranties of merchantability and fitness for a particular purpose) is limited to providing replacement parts during the term of this warranty. Some jurisdictions do not allow limitations on how long an implied warranty lasts, so this limitation may not apply to you. There are no rights, warranties or conditions, expressed or implied, statutory or otherwise, other than those contained in this warranty.

Roberts-Gordon LLC shall in no event be responsible for incidental or consequential damages or incur liability for damages in excess of the amount paid by you for the ROBERTS GORDON® UHA-Series. Some jurisdictions do not allow the exclusion or limitation of incidental or consequential damages, so this limitation or exclusion may not apply to you. This warranty gives you specific legal rights, and you may also have other rights which vary from jurisdiction to jurisdiction.

Roberts-Gordon LLC shall not be responsible for failure to perform under the terms of this warranty if caused by circumstances out of its control, including but not limited to war, fire, flood, strike, government or court orders, acts of God, terrorism, unavailability of supplies, parts or power. No person is authorized to assume for Roberts-Gordon LLC any other warranty, obligation or liability.

LIMITATIONS ON AUTHORITY OF REPRESENTATIVES:

No representative of Roberts-Gordon LLC, other than an Executive Officer, has authority to change or extend these provisions. Changes or extensions shall be binding only if confirmed in writing by Roberts-Gordon LLC's duly authorized Executive Officer.



OWNER WARRANTY REGISTRATION CARD

Mail or Fax to:

Roberts Gordon LLC • 1250 William Street, P.O. Box 44 • Buffalo, NY 14240-0044 • Phone: +1.716.852.4400 • Fax: +1.716.852.0854
Toll Free: 800-828-7450 • www.robertsgordon.com • www.rg-inc.com

About the Owner:

Name: _____
Address: _____ City: _____ State: _____ Zip Code: _____
Phone: _____ Fax: _____ E-mail: _____

About the Installer:

Name: _____
Address: _____ City: _____ State: _____ Zip Code: _____
Phone: _____ Fax: _____ E-mail: _____

Purchased From (if different than installer):

Name: _____
Address: _____ City: _____ State: _____ Zip Code: _____
Phone: _____ Fax: _____ E-mail: _____

About your Heater:

Model #: _____ Serial #: _____ Fuel: _____ Installation Date: _____

Type of Installation (check one):

- Automotive Manufacturing Warehouse Recreational Aircraft
 - Public Building Office Retail Agricultural Other _____
-

Installation Code and Annual Inspections: All installation and service of ROBERTS GORDON® equipment must be performed by a contractor qualified in the installation and service of equipment sold and supplied by Roberts-Gordon LLC and conform to all requirements set forth in the ROBERTS GORDON® manuals and all applicable governmental authorities pertaining to the installation, service, operation and labeling of the equipment. To help facilitate optimum performance and safety, Roberts-Gordon LLC recommends that a qualified contractor conduct, at a minimum, annual inspections of your ROBERTS GORDON® equipment and perform service where necessary, using only replacement parts sold and supplied by Roberts-Gordon LLC.

Further Information: Applications, engineering and detailed guidance on systems design, installation and equipment performance is available through ROBERTS GORDON® representatives. Please contact us for any further information you may require, including the Installation, Operation and Service Manual.

These products (with the exception of the models UHA[X][S] 30 - 75) are not approved for residential use.

© 2014 Roberts-Gordon LLC - All rights reserved. No part of this work covered by the copyrights herein may be reproduced or copied in any form or by any means – graphic, electronic, or mechanical, including photocopying, recording, taping, or information storage and retrieval systems – without written permission of Roberts Gordon LLC.

Printed in the U.S.A.

Attach this information to the wall near the ROBERTS GORDON® heater



Read the Installation, Operation and Service Manual thoroughly before installation, operation or service.

OPERATING INSTRUCTIONS

1. STOP! Read all safety instructions on this information sheet.
2. Open the manual gas valve in the heater supply line.
3. Turn on electric power to the heater.
4. Set the thermostat to desired setting (above ambient temperature).
The automatic starting sequence begins.

TO TURN OFF THE HEATER

1. Turn the thermostat/time switch to 'OFF' or lowest setting. The burner will turn 'OFF' immediately, but fans will continue to cool heat exchanger until the fan thermostat switches off.

IF THE HEATER WILL NOT OPERATE, TO ENSURE YOUR SAFETY, FOLLOW THESE INSTRUCTIONS TO SHUT DOWN YOUR HEATER

1. Set the thermostat to off or the lowest setting.
2. Turn off electric power to the heater.
3. Turn off the manual gas valve in the heater supply line.
4. Call your installer/contractor qualified in the installation and service of gas-fired heating equipment.

WARNING



Fire Hazard

Keep all flammable objects, liquids and vapors the minimum required clearances to combustibles away from heater.

Some objects will catch fire or explode when placed close to heater.

Failure to follow these instructions can result in death, injury or property damage.

Installation Clearances

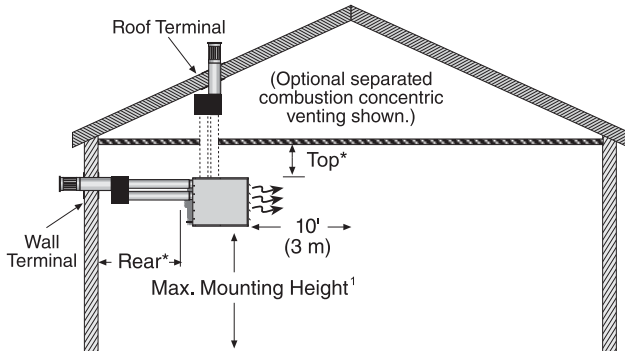

*Models	30 - 125	150 - 400
Top	1" (2.5 cm)	6" (15 cm)
Rear	18" (46 cm)	24" (61 cm)
Max. Mounting Height ¹	10' (3 m) - 16' (4.9 m)	18' (5.5 m) - 20' (6.1 m)

¹Heaters can be mounted higher if destratification fans are installed. See Installation, Operation and Service Manual for specific mounting height recommendations.
NOTE: Venting directly from top of heater not applicable on Models 150-400.

Clearances to Combustibles

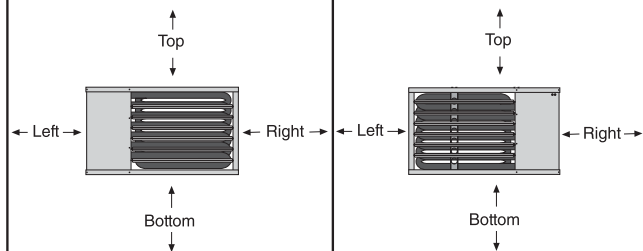

Models 30 - 125

Models 150 - 400

Models	30 - 125	150 - 400
Top	1" (2.5 cm)	6" (15 cm)
Bottom	0" (0 cm)	3" (8 cm)
Right	1" (2.5 cm)	31" (79 cm)*
Left	23" (58.4 cm)*	6" (15 cm)
Vent	2" (5 cm)	2" (5 cm)

* Clearance needed for servicing.

Installation Code and Annual Inspections: All installation and service of ROBERTS GORDON® equipment must be performed by a contractor qualified in the installation and service of equipment sold and supplied by Roberts-Gordon LLC and conform to all requirements set forth in the ROBERTS GORDON® manuals and all applicable governmental authorities pertaining to the installation, service, operation and labeling of the equipment. To help facilitate optimum performance and safety, Roberts-Gordon LLC recommends that a qualified contractor conduct, at a minimum, annual inspections of your ROBERTS GORDON® equipment and perform service where necessary, using only replacement parts sold and supplied by Roberts-Gordon LLC.

For installation at elevations above 2000' (610m), the appliance shall be derated 4% for each 1000' (305m) of elevation above sea level.

Further Information: Applications, engineering and detailed guidance on systems design, installation and equipment performance is available through ROBERTS GORDON® representatives. Please contact us for any further information you may require, including the Installation, Operation and Service Manual.

These products are not approved for residential use, except for models UHA[S]30-UHA[S]75.

© 2013 Roberts-Gordon LLC

All rights reserved. No part of this work covered by the copyrights herein may be reproduced or copied in any form or by any means – graphic, electronic, or mechanical, including photocopying, recording, taping, or information storage and retrieval systems – without written permission of Roberts-Gordon LLC.

Roberts-Gordon LLC
1250 William Street
P.O. Box 44
Buffalo, NY 14240-0044 USA
Telephone: +1.716.852.4400
Fax: +1.716.852.0854
Toll Free: 800.828.7450