

Model CRV-B

Custom-Engineered, Low-Intensity Infrared Heating Systems

Installation, Operation & Service Manual

CRV-B-2
CRV-B-4
CRV-B-6
CRV-B-8
CRV-B-9
CRV-B-10
CRV-B-12
CRV-B-12A

FOR YOUR SAFETY

If you smell gas:

1. Open windows.
2. **DO NOT** try to light any appliance.
3. **DO NOT** use electrical switches.
4. **DO NOT** use any telephone in your building.
5. Extinguish any open flame.
6. Leave the building.
7. Immediately call your local gas supplier after leaving the building. Follow the gas supplier's instructions.
8. If you cannot reach your gas supplier, call the Fire Department.

⚠ WARNING



Fire Hazard

Keep all flammable objects, liquids and vapors the minimum required clearances to combustibles away from heater.

Some objects will catch fire or explode when placed close to heater.

Failure to follow these instructions can result in death, injury or property damage.

⚠ WARNING

Improper installation, adjustment, alteration, service or maintenance can result in death, injury or property damage. Read the Installation, Operation and Service Manual thoroughly before installing or servicing this equipment.

Installation must be done by a contractor qualified in the installation and service of gas-fired heating equipment or your gas supplier.

Installer

Please take the time to read and understand these instructions prior to any installation. Installer must give a copy of this manual to the owner.

Owner

Keep this manual in a safe place in order to provide your service technician with necessary information.

Roberts-Gordon LLC

1250 William Street
P.O. Box 44
Buffalo, New York 14240-0044
Telephone: +1.716.852.4400
www.robertsgordon.com



This heater is not certified to meet the requirements of NFPA30A-2012 Section 7.6.6. (maximum tube temperature of 750° F (399° C). Do not install this heater in facilities where major repairs are conducted on compressed natural gas (CNG) or liquefied natural gas (LNG) fueled vehicles.

TABLE OF CONTENTS

SECTION 1: Heater Safety	1	10/12/12A Only)	55
1.1 Manpower Requirements	1	12.3 CORAYVAC® Modulating Thermostat.....	55
1.2 Safety Labels and Their Placement.....	1	12.4 DPDT Transformer Relay (P/N 90436300)	56
1.3 California Proposition 65	1	SECTION 13: Starting The System	66
SECTION 2: Installer Responsibility	4	13.1 Checking the Gas Line	66
2.1 Wall Tag	4	13.2 Checking the Electrical System	66
2.2 Corrosive Chemicals.....	4	13.3 Starting the System	66
2.3 National Standards and Applicable Codes.....	4	13.4 Setting the Vacuum.....	67
SECTION 3: Clearances to Combustibles	5	SECTION 14: Variable Frequency Drive Programming For Use	69
3.1 Required Clearances to Combustibles.....	5	With CORAYVAC® Modulating Heating Control	69
SECTION 4: National Standards and Applicable Codes	9	14.1 VFD Parameter Settings For Use With CORAYVAC®	69
4.1 Gas Codes.....	9	Modulating Heating Control	69
4.2 Aircraft Hangars	9	14.2 Altering VFD Parameters For Use With CORAYVAC®	70
4.3 Public Garages	9	Modulating Heating Control	70
4.4 Electrical	9	SECTION 15: Variable Frequency Drive Programming For Use	71
4.5 Venting.....	9	With CORAYVAC® System With Modulating Thermostat ...	71
4.6 High Altitude	9	15.1 VFD Parameter Settings For Use With Modulating	71
SECTION 5: Major Components	10	Thermostats.....	71
5.1 Standard Parts List	16	15.2 Altering VFD Parameters For Use With CORAYVAC®	72
SECTION 6: Design Requirements	18	System With Modulating Thermostat	72
SECTION 7: Heater Installation	20	SECTION 16: Commissioning The CORAYVAC® Modulating	73
7.1 Tube Installation	23	System	73
7.2 Coupling and Tube Assembly.....	23	16.1 Setting The CORAYVAC® End Burner Vacuum	73
7.3 Reflector Installation	25	16.2 Adjusting the Variable Frequency Drive	73
7.4 Burner Installation.....	28	SECTION 17: Operation and Maintenance	75
SECTION 8: Optional Heater Accessories	29	17.1 Sequence of Operation	75
8.1 U-Tube Configuration	29	17.2 To Shut Off Heater.....	75
8.2 Tee Installation	30	17.3 To Start Heater	75
8.3 Reflector Joint.....	31	17.4 Pre-Season Maintenance and Annual Inspection.....	75
8.4 Reflector Side Extension.....	33	17.5 Maintenance Checklist	76
8.5 Universal Shield.....	34	SECTION 18: Troubleshooting	78
8.6 Barrier Shield.....	34	18.1 Troubleshooting Flow Chart	79
8.7 Two-Foot Decorative Grille Installation.....	35	SECTION 19: Replacement Parts	81
8.8 Protective Grille Installation.....	37	19.1 Replacement Parts Instructions.....	83
SECTION 9: Pump Installation and Venting	38	SECTION 20: General Specifications	84
9.1 Pump Installation	38	20.1 Material Specifications.....	84
9.2 General Venting Requirements Model EP-100, EP-200	43	20.2 Heater Specifications.....	84
and EP-300 Series Pumps.....	43	20.3 Suspension Specifications	84
9.3 Tube Length vs Efficiency	45	20.4 Controls Specifications	84
SECTION 10: Outside Air Supply	49	SECTION 21: The ROBERTS GORDON® CORAYVAC® Limited	87
10.1 Pressurized	49	Warranty	87
10.2 Non-Pressurized	49		
10.3 Outside Air Blower Internal Wiring	50		
SECTION 11: Gas Piping	53		
SECTION 12: Control Methods	55		
12.1 CORAYVAC® Heating Control	55		
12.2 CORAYVAC® Modulating Heating Control (CRV-B 6/8/9/			

There are references in this manual to various trademarks. All trademarks mentioned herein, whether registered or not, are the property of their respective owners. Roberts-Gordon LLC is not sponsored by or affiliated with any of the trademark or registered trademark owners, and make no representations about them, their owners, their products or services. Roberts-Gordon LLC is not sponsored by or affiliated with BACnet®, LonWorks® or MODBUS®.

© 2021 Roberts-Gordon LLC

All rights reserved. No part of this work covered by the copyrights herein may be reproduced or copied in any form or by any means - graphic, electronic, or mechanical, including photocopying, recording, taping or information storage and retrieval systems - without the written permission of Roberts-Gordon LLC.

SECTION 1: HEATER SAFETY

Your Safety is Important to Us!
This symbol is used throughout the manual to notify you of possible fire, electrical or burn hazards. Please pay special attention when reading and following the warnings in these

sections.

Installation, service and annual inspection of heater must be done by a contractor qualified in the installation and service of gas-fired heating equipment.

Read this manual carefully before installation, operation or service of this equipment.

This heater is designed for heating nonresidential indoor spaces. Do not install in residential spaces. This heater is not certified to meet the requirements of NFPA30A-2012 Section 7.6.6. (maximum tube temperature of 750 °F (399 °C)). Do not install this heater in facilities where compressed natural gas (CNG) or liquid natural gas (LNG) are present. These instructions, the layout drawing, local codes and ordinances, and applicable standards that apply to gas piping, electrical wiring, venting, etc. must be thoroughly understood before proceeding with the installation.

Protective gear is to be worn during installation, operation and service in accordance to the Occupational Safety and Hazard Administration (OSHA). Gear must be in accordance to NFPA 70E, latest revision when working with electrical components. Thin sheet metal parts have sharp edges. To prevent injury, the use of work gloves is recommended. The use of gloves will also prevent the transfer of body oils from the hands to the surface of the reflector.

Before installation, check that local distribution conditions, nature of gas and pressure, and adjustment of the appliance are compatible.

This heater must be applied and operated under the general concepts of reasonable use and installed using best building practices.

This appliance is not intended for use by persons (including children) with reduced physical, sensory or mental capabilities, or lack of experience and knowledge, unless they have been given supervision or instruction concerning use of the appliance by a person responsible for their safety. Children should be supervised to ensure that they do no play with the appliance.

For additional copies of the Installation, Operation and Service Manual, please contact Roberts-Gordon LLC.

1.1 Manpower Requirements

To prevent personal injury and damage to the heater, two persons will be required for installation.

1.2 Safety Labels and Their Placement

Product safety signs or labels should be replaced by the product user when they are no longer legible. Please contact Roberts-Gordon LLC or your ROBERTS GORDON® independent distributor to obtain replacement signs or labels. See *Page 2, Figure 1 through Page 3, Figure 2*.

1.3 California Proposition 65

In accordance with California Proposition 65 requirements, a warning label must be placed in a highly visible location on the outside of the equipment (i.e., near equipment's serial plate). See label placement drawing on *Page 2, Figure 1* for label location. Avoid placing label on areas with extreme heat, cold, corrosive chemicals or other elements. To order additional labels, please contact Roberts-Gordon LLC or your ROBERTS GORDON® independent distributor.

FIGURE 1: Side Panel Label Placement

Control Side Panel

Rating Plate Label

Logo Label

Internal Ladder Diagram Label

Filter Side Panel (inside)

Wiring Label

Description	Part Number
Logo Label	91013224
Rating Plate Label	91010401
Clearances to Combustibles Label	91009101
Internal Ladder Diagram Label	91017301
Wiring Label	91017300

FIGURE 2: Top and Back Panel Label Placement

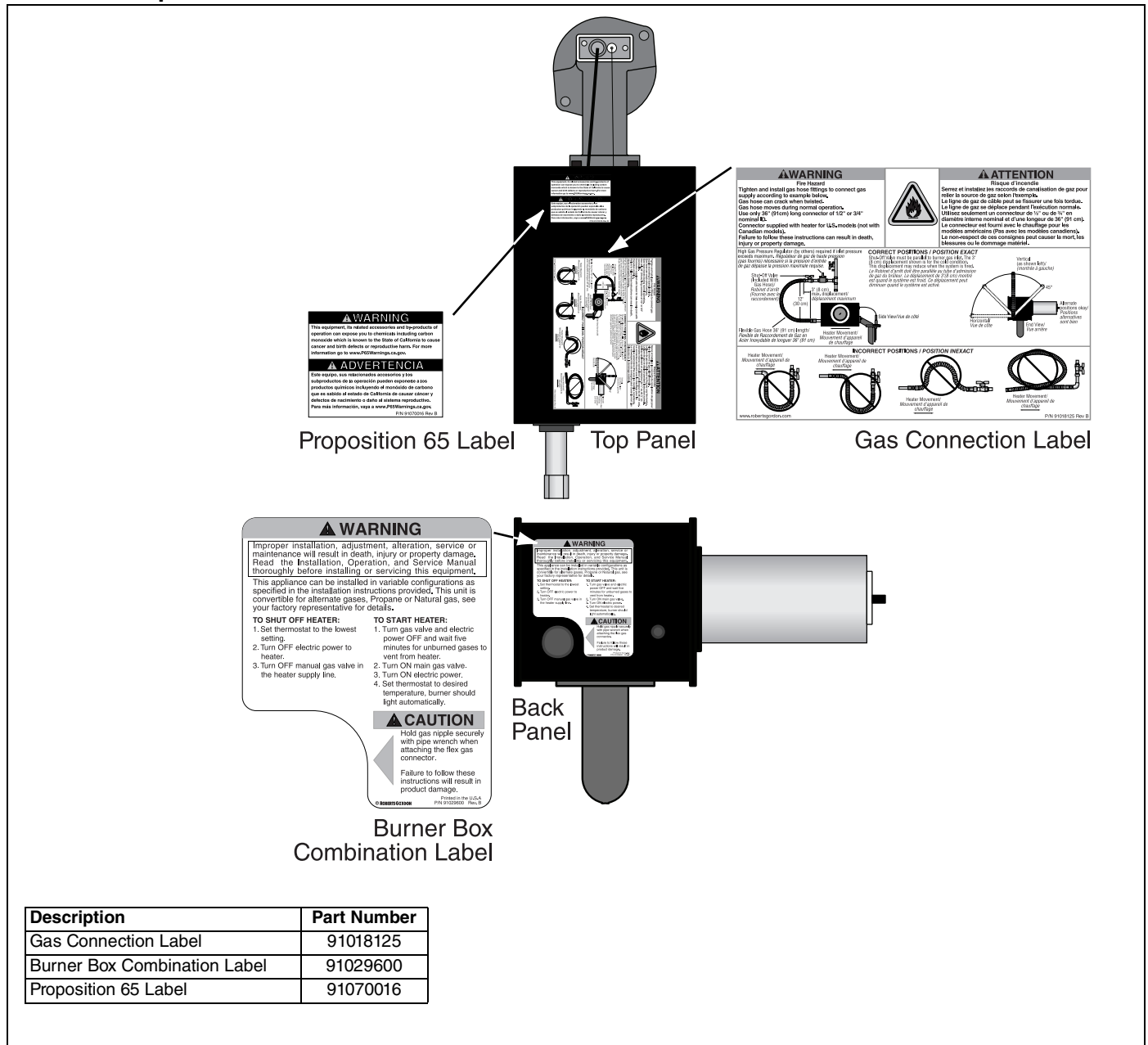

Description	Part Number
Gas Connection Label	91018125
Burner Box Combination Label	91029600
Proposition 65 Label	91070016

SECTION 2: INSTALLER RESPONSIBILITY

The installer is responsible for the following:

- To ensure the system is designed in accordance with the parameters of the CRV-Series Design Manual (P/N 127500NA).
- To install the heater, as well as the gas and electrical supplies, in accordance with applicable specifications and codes. Roberts-Gordon LLC recommends the installer contact a local Building Inspector or Fire Marshal for guidance.
- To use the information given in a layout drawing and in the manual together with the cited codes and regulations to perform the installation.
- To install the heater in accordance with the clearances to combustibles requirements.
- To furnish all needed materials not furnished as standard equipment.
- To plan location of supports.
- To provide access to burners on all sides for servicing or burner removal.
- To provide the owner with a copy of this Installation, Operation and Service Manual.
- To never use heater as a support for ladder or other access equipment and to never hang or suspend anything from heater.
- To ensure there is adequate air circulation around the heater and to supply air for combustion, ventilation and distribution in accordance with local codes.
- To safely and adequately install heater using materials with a minimal working load of 75 lb (33 kg).
- To ensure the heater is placed in an approved application.

2.1 Wall Tag

A laminated wall tag is available for the heater as a permanent reminder of the safety instructions and the importance of the required clearances to combustibles. Please contact Roberts-Gordon LLC or your ROBERTS GORDON® independent distributor to obtain the wall tag. Affix the tag by peeling off the backing of the adhesive strips on the rear surface and position the tag on a wall near the CRV-Series heater (e.g. thermostat or controller). A copy of the wall tag (P/N 91037912) is illustrated on the back cover. For an immediate solution, you may affix this copy on the wall near the heater. Know your model number and installed configuration. Model number and installed configuration are found on the burner and in the Installation, Operation and Service Manual. See Page 6, Figure 3 through Page 8, Figure 11. Write the proper clearance dimensions in permanent ink according to your model number and configuration in the open spaces on the tag.

2.2 Corrosive Chemicals

<p>Product Damage Hazard</p> <p>Do not use heater in area containing corrosive chemicals.</p> <p>Refer to appropriate Material Safety Data Sheets (MSDS).</p> <p>Failure to follow these instructions can result in product damage.</p>

Roberts-Gordon LLC cannot be responsible for ensuring that all appropriate safety measures are undertaken prior to installation; this is entirely the responsibility of the installer. It is essential that the contractor, the sub-contractor, or the owner identifies the presence of combustible materials, corrosive chemicals or halogenated hydrocarbons* anywhere in the premises.

* **Halogenated Hydrocarbons** are a family of chemical compounds characterized by the presence of halogen elements (fluorine, chlorine, bromine, etc.). These compounds are frequently used in refrigerants, cleaning agents, solvents, etc. If these compounds enter the air supply of the burner, the life span of the heater components will be greatly reduced. An outside air supply must be provided to the burners whenever the presence of these compounds is suspected. Warranty will be invalid if the heater is exposed to halogenated hydrocarbons.

2.3 National Standards and Applicable Codes

All appliances must be installed in accordance with the latest revision of the applicable standards and national codes. This refers also to the electric, gas and venting installation. Note: Additional standards for installations in public garages, aircraft hangars, etc. may be applicable.

SECTION 3: CLEARANCES TO COMBUSTIBLES

3.1 Required Clearances to Combustibles

Clearances are the required distances that combustible objects must be away from the heater to prevent serious fire hazards. Combustibles are materials that may catch fire and include common items such as wood, paper, rubber, fabric, etc.

Maintain clearances to combustibles at all times for safety.

Clearances for all heater models are located on the burner of the heater and on Page 6, Figure 3 through Page 8, Figure 11 in this manual. Check the clearances on each burner for the model heater being installed to make sure the product is suitable for your application and the clearances are maintained. Read and follow the safety guidelines below:

- Keep gasoline or other combustible materials including flammable objects, liquids, dust or vapors away from this heater or any other appliance.
- The stated clearances to combustibles represents a surface temperature of 90° F (32°C) above room temperature. Building materials with a low heat tolerance (such as plastics, vinyl siding, canvas, tri-ply, etc) may be subject to degradation at lower temperatures. It is the installer's responsibility to assure that adjacent materials are protected from degradation.
- Maintain clearances from heat sensitive equipment and workstations.
- Maintain clearances from vehicles parked below the heater.
- Maintain clearances from swinging and overhead doors, overhead cranes, vehicle lifts, partitions, storage racks, hoists, building construction, etc.
- In locations used for the storage of combustible materials, signs must be posted to specify the maximum permissible stacking height to maintain required clearances from the heater to the combustibles. Signs must be posted adjacent to the heater thermostat. In the absence of a thermostat, signs must be posted in a conspicuous location.
- Consult local Fire Marshal, Fire Insurance Carrier or other authorities for approval of proposed installation when there is a possibility of exposure to combustible airborne materials or vapors.
- Hang heater in accordance to the minimum suspension requirements on Page 21, Figure 20.
- If the radiant tubes must pass through the building structure, be sure that adequate sleeving and fire

stop is installed to prevent scorching and/or fire hazard.

⚠ WARNING

Fire Hazard
<p>Keep all flammable objects, liquids and vapors the minimum required clearances to combustibles away from heater.</p> <p>Some objects will catch fire or explode when placed close to heater.</p> <p>Failure to follow these instructions can result in death, injury or property damage.</p>

- NOTE:** 1. All dimensions are from the surfaces of all tubes, couplings, elbows, tees and crosses.
 2. Clearances B, C and D can be reduced by 50% after 25' (7.5 m) of tubing downstream from where the combustion chamber and the tube connect.

FIGURE 3: LEVEL REFLECTOR

	Model	(inches)				(centimeters)			
		A	B	C	D	A	B	C	D
	CRV-B-2	4	20	48	20	11	51	122	51
	CRV-B-4	4	20	48	20	11	51	122	51
	CRV-B-6	4	20	48	20	11	51	122	51
	CRV-B-8	4	20	48	20	11	51	122	51
	CRV-B-9	4	36	60	36	11	92	153	92
	CRV-B-10	4	36	60	36	11	92	153	92
	CRV-B-12	4	36	60	36	11	92	153	92
	CRV-B-12A	4	36	60	36	11	92	153	92

FIGURE 4: ONE SIDE REFLECTOR

	Model	(inches)				(centimeters)			
		A	B	C	D	A	B	C	D
	CRV-B-2	4	12	56	20	11	31	143	51
	CRV-B-4	4	12	56	20	11	31	143	51
	CRV-B-6	4	12	56	20	11	31	143	51
	CRV-B-8	4	12	56	20	11	31	143	51
	CRV-B-9	4	12	60	42	11	31	153	107
	CRV-B-10	4	12	60	42	11	31	153	107
	CRV-B-12	4	12	60	42	11	31	153	107
	CRV-B-12A	4	12	60	42	11	31	153	107

FIGURE 5: TWO SIDE REFLECTORS

	Model	(inches)				(centimeters)			
		A	B	C	D	A	B	C	D
	CRV-B-2	4	12	56	12	11	31	143	31
	CRV-B-4	4	12	56	12	11	31	143	31
	CRV-B-6	4	12	56	12	11	31	143	31
	CRV-B-8	4	12	56	12	11	31	143	31
	CRV-B-9	4	12	60	12	11	31	153	31
	CRV-B-10	4	12	60	12	11	31	153	31
	CRV-B-12	4	12	60	12	11	31	153	31
	CRV-B-12A	4	12	60	12	11	31	153	31

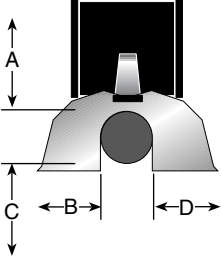
- NOTE:**
1. All dimensions are from the surfaces of all tubes, couplings, elbows, tees and crosses.
 2. Clearances B, C and D can be reduced by 50% after 25' (7.5 m) of tubing downstream from where the combustion chamber and the tube connect.

FIGURE 6: UNIVERSAL SHIELD (WITH AND WITHOUT HOLES), POSITION 1

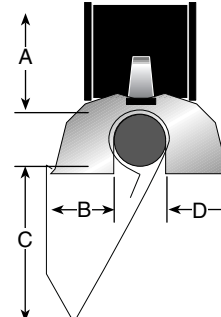
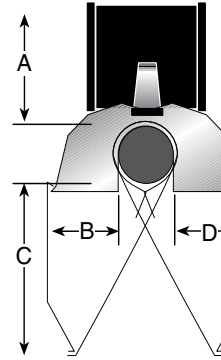
	Model	(inches)				(centimeters)			
		A	B	C	D	A	B	C	D
	CRV-B-2	4	12	12	12	11	31	31	31
	CRV-B-4	4	12	12	12	11	31	31	31
	CRV-B-6	4	12	12	12	11	31	31	31
	CRV-B-8	4	12	12	12	11	31	31	31
	CRV-B-9	8	18	24	18	21	46	61	46
	CRV-B-10	8	18	24	18	21	46	61	46
	CRV-B-12	8	18	24	18	21	46	61	46
	CRV-B-12A	8	18	24	18	21	46	61	46

FIGURE 7: UNIVERSAL SHIELD (WITH AND WITHOUT HOLES), POSITION 2

	Model	(inches)				(centimeters)			
		A	B	C	D	A	B	C	D
	CRV-B-2	4	24	48	24	11	61	122	61
	CRV-B-4	4	24	48	24	11	61	122	61
	CRV-B-6	4	24	48	24	11	61	122	61
	CRV-B-8	4	24	48	24	11	61	122	61
	CRV-B-9	4	36	48	36	11	92	122	92
	CRV-B-10	4	36	48	36	11	92	122	92
	CRV-B-12	4	36	48	36	11	92	122	92
	CRV-B-12A	4	36	48	36	11	92	122	92

FIGURE 8: UNIVERSAL SHIELD (WITH AND WITHOUT HOLES), POSITION 3

	Model	(inches)				(centimeters)			
		A	B	C	D	A	B	C	D
	CRV-B-2	4	12	56	30	11	31	143	77
	CRV-B-4	4	12	56	30	11	31	143	77
	CRV-B-6	4	12	56	30	11	31	143	77
	CRV-B-8	4	12	56	30	11	31	143	77
	CRV-B-9	8	12	60	42	21	31	153	107
	CRV-B-10	8	12	60	42	21	31	153	107
	CRV-B-12	8	12	60	42	21	31	153	107
	CRV-B-12A	8	12	60	42	21	31	153	107

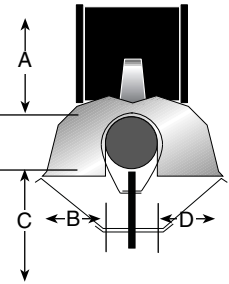
- NOTE:**
1. All dimensions are from the surfaces of all tubes, couplings, elbows, tees and crosses.
 2. Clearances B, C and D can be reduced by 50% after 25' (7.5 m) of tubing downstream from where the combustion chamber and the tube connect.

FIGURE 9: 2-FOOT DECO GRILLE

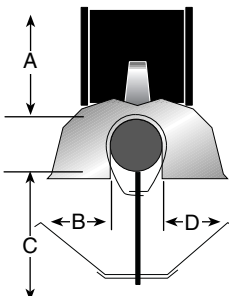
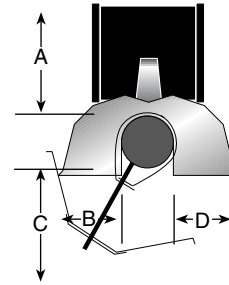
	Model	(inches)				(centimeters)			
		A	B	C	D	A	B	C	D
	CRV-B-2	4	12	48	12	11	31	122	31
	CRV-B-4	4	12	48	12	11	31	122	31
	CRV-B-6	4	12	48	12	11	31	122	31
	CRV-B-8	4	12	48	12	11	31	122	31
	CRV-B-9	4	18	56	18	11	46	143	46
	CRV-B-10	4	18	56	18	11	46	143	46
	CRV-B-12	4	18	56	18	11	46	143	46
	CRV-B-12A	4	18	56	18	11	46	143	46

FIGURE 10: BARRIER SHIELD

	Model	(inches)				(centimeters)			
		A	B	C	D	A	B	C	D
	CRV-B-2	4	12	12	12	11	31	31	31
	CRV-B-4	4	12	12	12	11	31	31	31
	CRV-B-6	4	12	12	12	11	31	31	31
	CRV-B-8	4	12	12	12	11	31	31	31
	CRV-B-9	- UNAPPROVED -				- UNAPPROVED -			
	CRV-B-10	- UNAPPROVED -				- UNAPPROVED -			
	CRV-B-12	- UNAPPROVED -				- UNAPPROVED -			
	CRV-B-12A	- UNAPPROVED -				- UNAPPROVED -			

FIGURE 11: PROTECTIVE GRILLE

	Model	(inches)				(centimeters)			
		A	B	C	D	A	B	C	D
	CRV-B-2	4	20	48	20	11	51	122	51
	CRV-B-4	4	20	48	20	11	51	122	51
	CRV-B-6	4	20	48	20	11	51	122	51
	CRV-B-8	4	20	48	20	11	51	122	51
	CRV-B-9	4	36	60	36	11	92	153	92
	CRV-B-10	4	36	60	36	11	92	153	92
	CRV-B-12	4	36	60	36	11	92	153	92
	CRV-B-12A	4	36	60	36	11	92	153	92

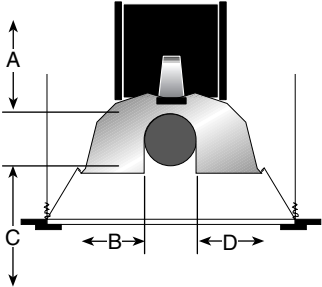
SECTION 4: NATIONAL STANDARDS AND APPLICABLE CODES

4.1 Gas Codes

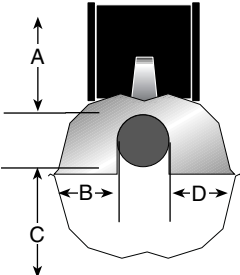
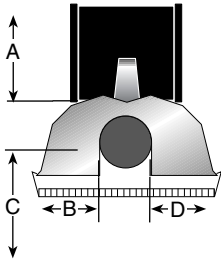
The type of gas appearing on the nameplate must be the type of gas used. Installation must comply with national and local codes and requirements of the local gas company.

United States: Refer to National Fuel Gas Code NFPA 54/ANSI Z223.1 - latest revision.

Canada: Refer to Natural Gas and Propane Installation Code CSA B149.1 - latest revision.

4.2 Aircraft Hangars

Installation in aircraft hangars must be in accordance with the following codes:

United States: Refer to Standard for Aircraft Hangars, NFPA 409 - latest revision.

Canada: Refer to Natural Gas and Propane Installation Code CSA B149.1 - latest revision.

In aircraft storage and servicing areas, heaters shall be installed at least 10' (3 m) above the upper surface of wings or of engine enclosures of the highest aircraft which may be housed in the hangar. The measurement shall be made from the wing or engine enclosure (whichever is higher from the floor) to the bottom of the heater.

- In shops, offices and other sections of aircraft hangars communicating with aircraft storage or servicing areas, heaters shall be installed not less than 8' (2.4 m) above the floor.
- Suspended or elevated heaters shall be so located in all spaces of aircraft hangars that they shall not be subject to injury by aircraft, cranes, movable scaffolding or other objects. Provisions shall be made to assure accessibility to suspended heaters for recurrent maintenance purposes.

4.3 Public Garages

Installation in garages must be in accordance with the following codes:

United States: Refer to Standard for Parking Structures NFPA 88A - latest revision or the Code for Motor Fuel Dispensing Facilities and Repair Garages, NFPA 30A - latest revision.
Canada: Refer to Natural Gas and Propane Installation Code CSA B149.1 - latest revision.

- Heaters must not be installed less than 8' (2.4 m) above the floor. Minimum clearances to combustibles must be maintained from vehicles parked below the heater.
- When installed over hoists, minimum clearances to combustibles must be maintained from the upper most point of objects on the hoist.

4.4 Electrical

The heater must be electrically grounded in accordance with the following codes:

United States: Refer to National Electrical Code®, NFPA 70 - latest revision. Wiring must conform to the most current National Electrical Code®, local ordinances and any special diagrams furnished.

Canada: Refer to Canadian Electrical Code, CSA C22.1 Part 1 - latest revision.

4.5 Venting

The venting must be installed in accordance with the requirements within this manual and the following codes:

United States: Refer to National Fuel Gas Code NFPA 54/ANSI Z223.1 - latest revision.

Canada: Refer to Natural Gas and Propane Installation Code CSA B149.1 - latest revision.

4.6 High Altitude

These heaters are approved for installations up to 2000' (610 m)(US), 4500' (1370 m)(Canada) without modification. Consult factory if US installation is above 2000' (610 m) or Canadian installation is above 4500' (1370 m).

The heater will need to be de-rated 4% per each 1000 ft (305m) of elevation above sea level.

SECTION 5: MAJOR COMPONENTS

The figures in this section provide a general overview of component placement in a CRV-Series system. The location of some components such as supports and couplings is crucial for proper installation. Assemble the heater components as shown on Page 19, Figure 19.

Optional reflector configurations are shown on Page 6, Figure 3 through Page 8, Figure 11. Install appropriate suspension hardware, beam clamps, chain or rod at predetermined locations. Adjustments of chain length will provide uniform pitch.

FIGURE 12: Major Component Descriptions - Standard Reflector

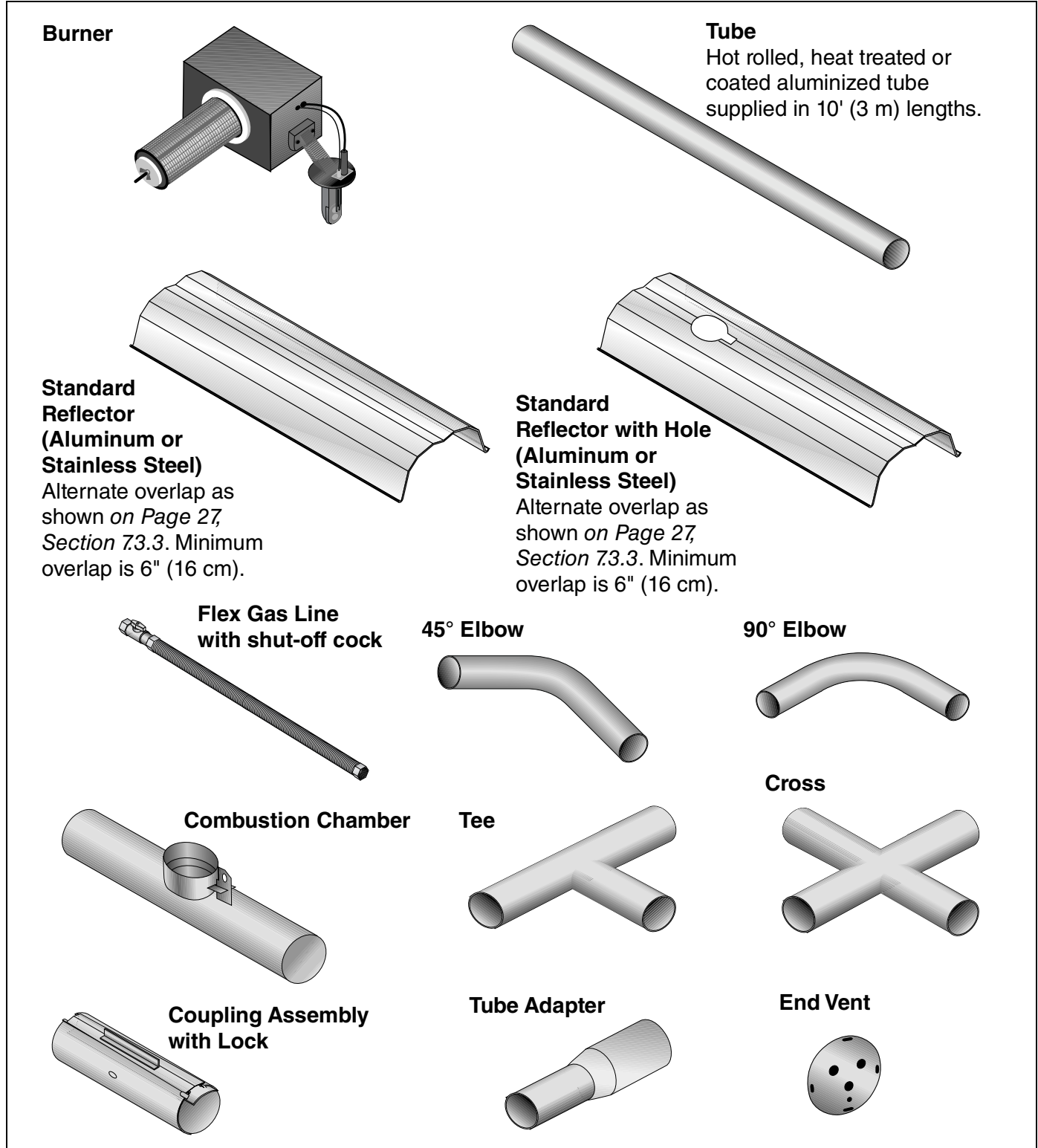

FIGURE 13: Major Component Descriptions - Standard Reflector (Continued)

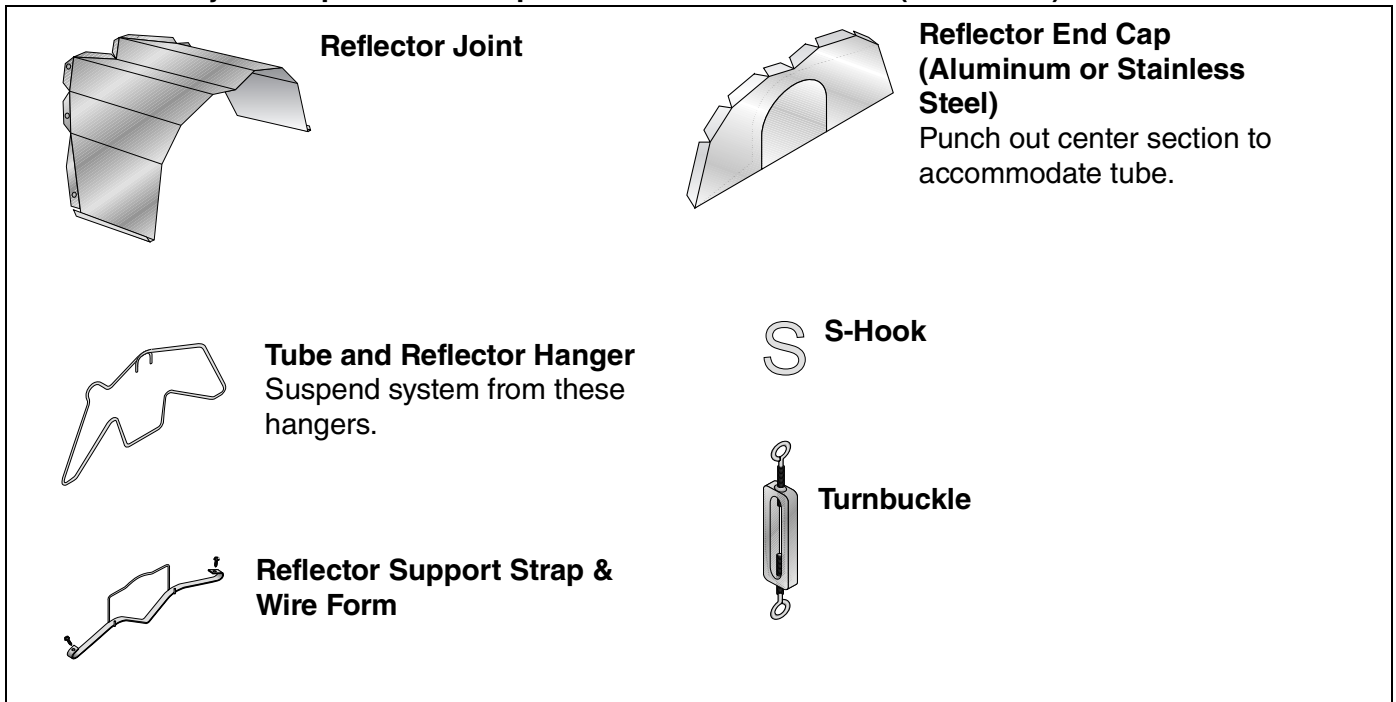

FIGURE 14: Classic System Component Descriptions - Standard or High Efficiency Reflector

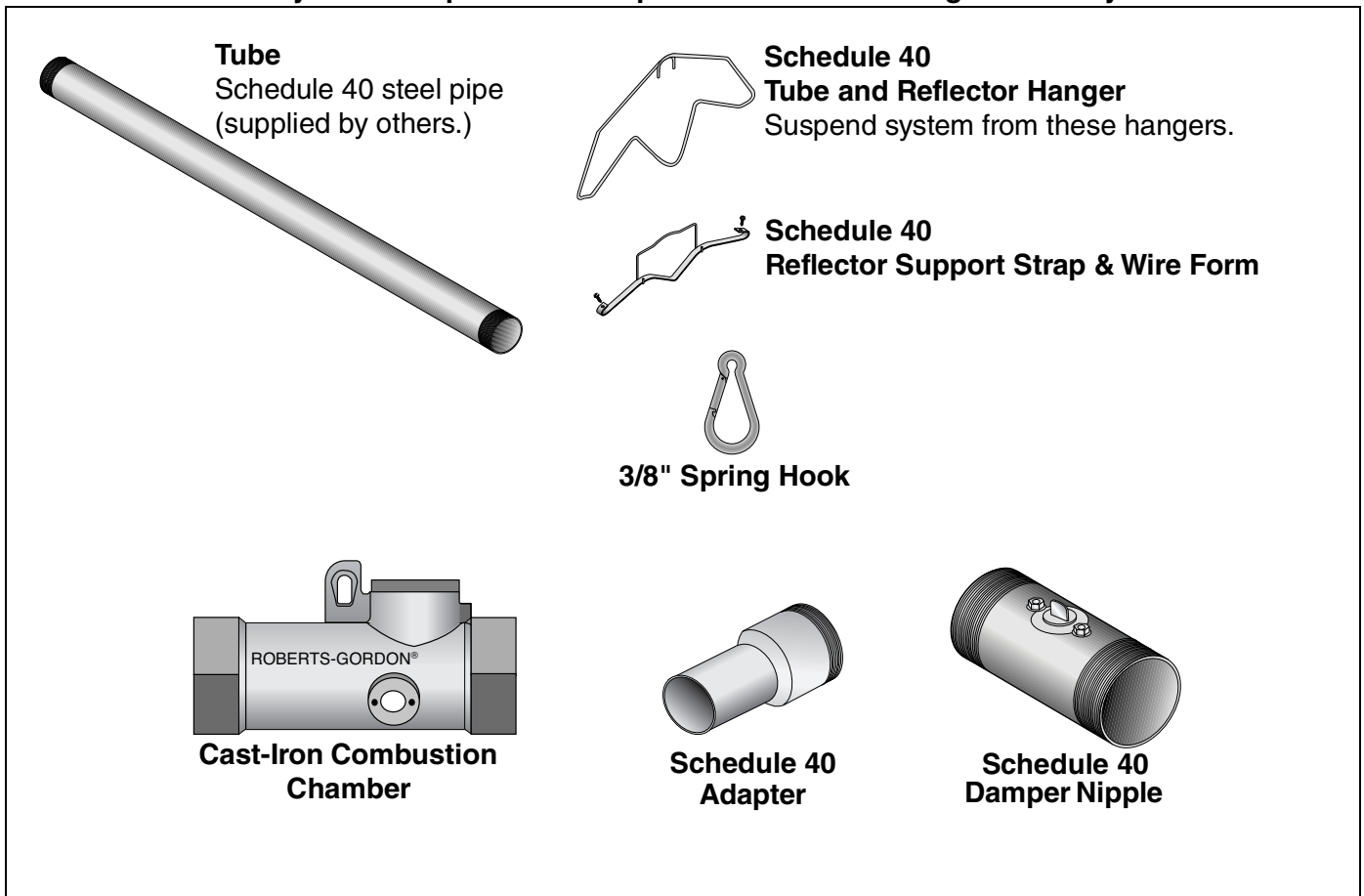

FIGURE 15: Major Component Descriptions - High Efficiency Reflector

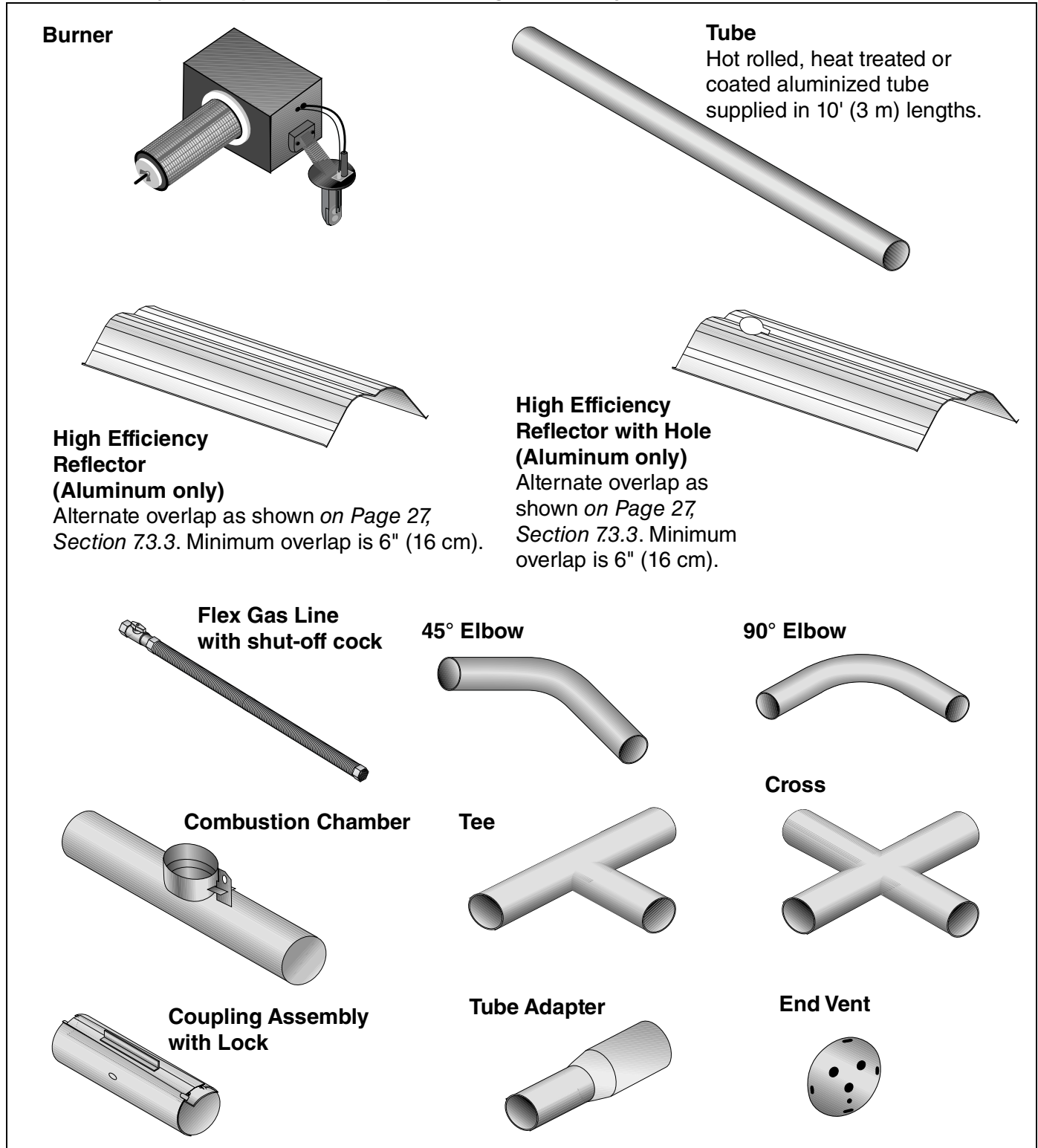

FIGURE 16: Major Component Descriptions - High Efficiency Reflector (Continued)

FIGURE 17: Optional Heater Accessories



Barrier Shield

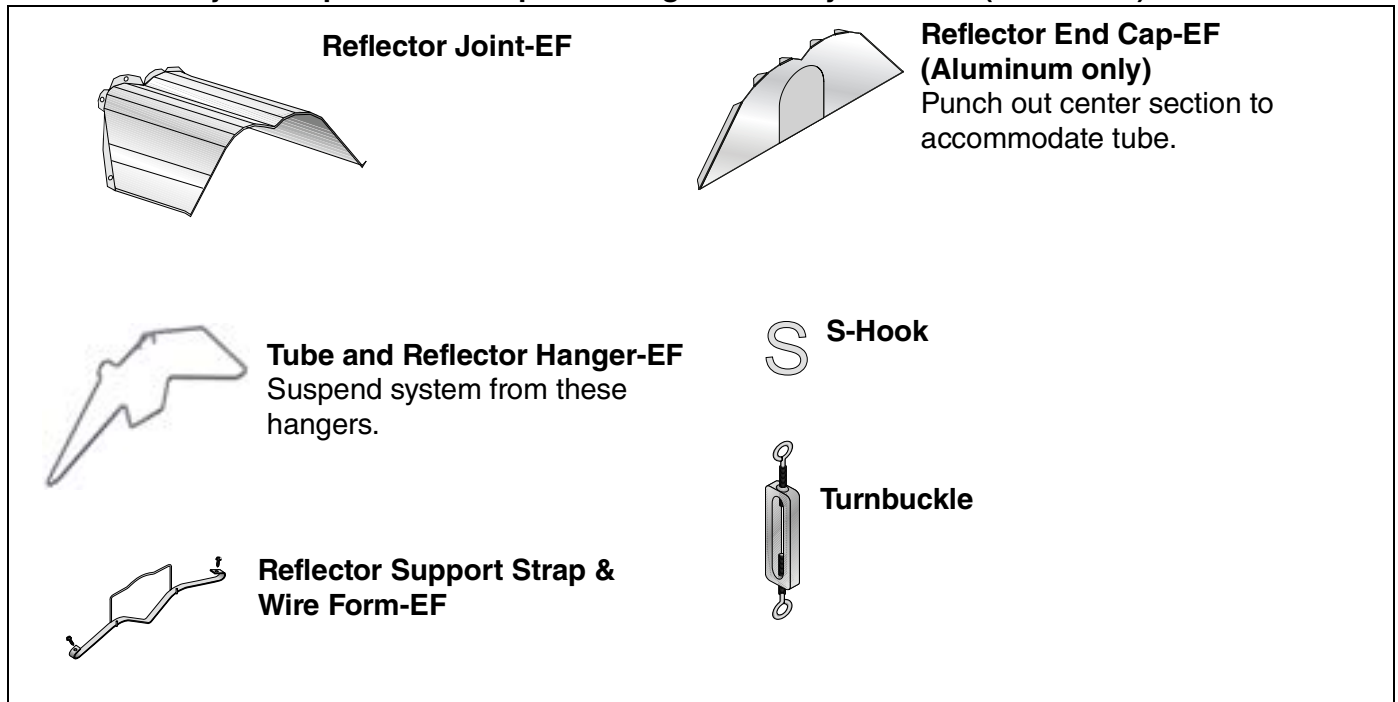
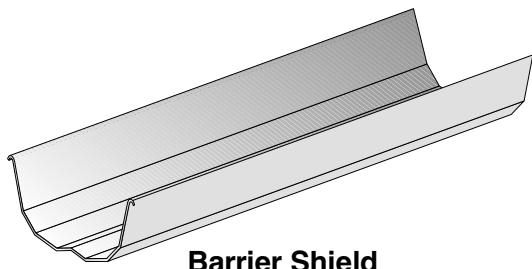
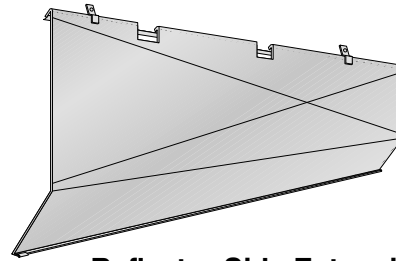

Reflector Side Extension

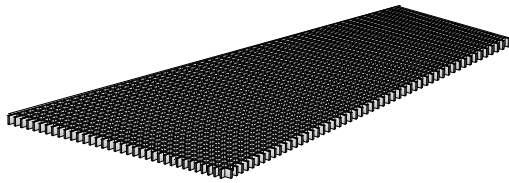

Deco Grille

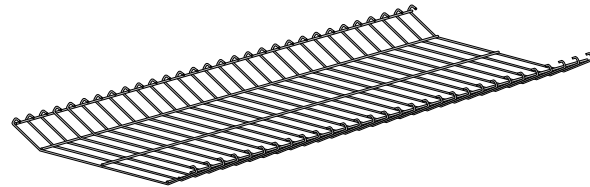

Protective Grille

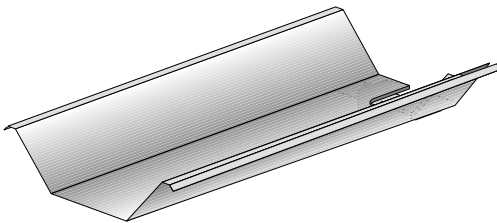

Universal Shield

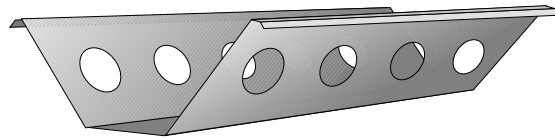

Universal Shield with Holes

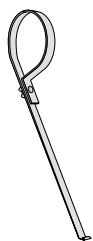

Reflector Side Extension Bracket



Condensate Valve Assembly

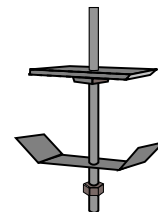

Bracket Assembly

FIGURE 18: Pumps and Controls Descriptions



CORAYVAC® Modulating Heating Control
 (Models CRV-B-6, B-8, B-9, B-10 or B-12 Only)

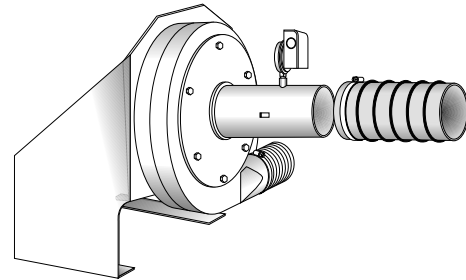

EP-100 Pump Package - 4" dia
 For more information, refer to the EP-100
 Installation, Operation and Service Manual
 (P/N 127201NA).



CORAYVAC® Heating Control

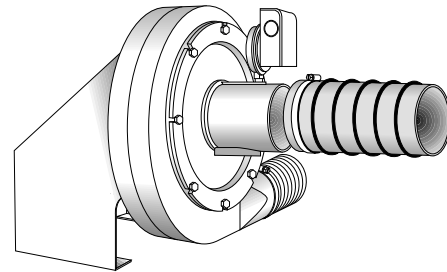

EP-201 Pump Package - 4" dia
EP-203 Pump Package - 4" dia
 For more information, refer to the EP-200
 Series Installation, Operation and Service
 Manual (P/N 127200NA).



Adjustable Indoor Sensor
 (P/N 10061003)

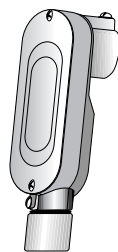

Outdoor Sensor
 (P/N 10081501)

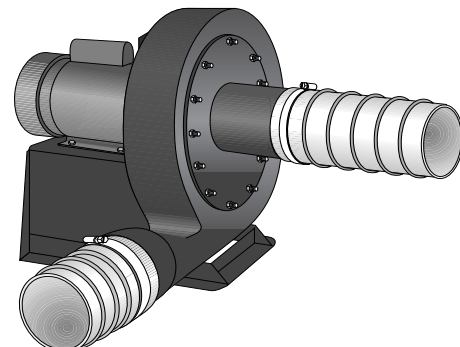

EP-301 Pump Package - 4" dia
EP-301 Pump Package - 6" dia
EP-303 Pump Package - 4" dia
EP-303 Pump Package - 6" dia
 For more information, refer to the
 EP-300 Series Installation, Operation and
 Service Manual (P/N 127202NA).

5.1 Standard Parts List

Table 1: Contents of CRV-Series Burner Carton

Part No.	Description
0270XXXX	Burner (Rate and Fuel Varies)
*91412200	Flexible Stainless Steel Gas Hose, 1/2" NPT (US models only)
013676XX	End Vent Plate
01397300	Accessory Package
01361200	Filter Support Disk
01367800	Combustion Chamber Gasket
02724901	Door Assembly w/ Hole
91115100	Screw #10 - 24 x 5/8
91119500	U-Clip
91905500	Filter Support
92123900	Nut 5/16 - 18
92511601	Wing Nut #10 - 24
96411600	Lock Washer 5/16"
01312401	Filter and Gasket

* Canadian Models: Rubber (Type 1) Gas Hoses available as an accessory. See Page 53, Figure 38.

Table 2: Common CRV-Series Components

Part No.	Description
Combustion Chambers	
02722300-1P	Hot Rolled Steel Combustion Chamber
02722301-1P	Heat-Treated Aluminized Steel Combustion Chamber
0272230D-1P	Porcelain Coated Steel Combustion Chamber
02721200-1P	Cast Iron Combustion Chamber

Part No.	Description
Tubing and Related Accessories	
01312700	Coupling, 4" (10 cm) Plain
01312706	Coupling, 6" (15 cm) Plain
01312701	Coupling, 4" (10 cm) Lined
01331900	Coupling, 4" (10 cm) Damper
E0009356	Coupling, 6" (15 cm) Damper
0133022D	Tee, 4" (10 cm) Coated
01330203	Tee, 4" (10 cm) Aluminized
01330204	Tee, 6" (15 cm) Aluminized
0133092D	Cross, 4" (10 cm) Coated
01330903	Cross, 4" (10 cm) Aluminized
01330904	Cross, 6" (15 cm) Aluminized
01335801	Elbow, 4" (10 cm) Aluminized 90°
T0100320	Elbow, 6" (15 cm) Aluminized 90°
0133580D	Elbow, 4" (10 cm) Coated 90°
01336101	Elbow, 4" (10 cm) Aluminized 45°
0133610D	Elbow, 4" (10 cm) Coated 45°
91409300	Tube, Hot Rolled Steel 4" (10 cm) dia 10' (3 m)
91409403	Tube, Non-Heat Treated Aluminized 4" (10 cm) dia 10' (3 m)
91409408	Tube, Heat Treated Aluminized 4" (10 cm) dia 10' (3 m)
91409420	Tube, Non-Heat Treated Aluminized 6" (15 cm) dia 10' (3 m)
9141030D	Tube, Coated 4" (10 cm) dia 10' (3 m)
E0009105	Tube, Heat Treated Aluminized 6" (15 cm) dia 10' (3 m)

Part No.	Description
91418200	Tube Adapter, Aluminized 6" (15 cm) dia x 4" (10 cm) dia
02722100	Adapter, 4" (10 cm) Cast Iron
91240010	Tube Hanger, 6" (15 cm)
91308001	High Temperature Pipe Compound, 1lb. can

Part No.	Description
Venting Accessories	
01324401	Outside Air Supply Takeoff, 4" (10 cm)
01326801	Outside Air Filter Housing
90707501	Air Supply Blower/Power Venter
91409601	Outside Air Flex Duct, 4" (10 cm) (Box of 9 - 8' [2.4 m] sections)

Part No.	Description
Reflectors and Related Accessories	
01329911	Reflector Side Extension Support
03050010	Reflector Support Package
03050012	Reflector Support Package - EF
02716401	Reflector Support Package - EF (Schedule 40 Pipe)
02712700	Reflector Side Extension, 96" (244 cm)
02712702	Reflector Side Extension, 96" (244cm) - EF
02716400	Reflector Support Package (Schedule 40 Pipe)
02750303	Reflector, Aluminum, 96" (244 cm)
02750313	High Efficiency Reflector, Aluminum, 96" (244 cm)
027503SS	Reflector, Stainless Steel, 96" (244 cm)
02750304	Reflector, Aluminum with Hole, 96" (244 cm)
02750314	High Efficiency Reflector, Aluminum with Hole, 96" (244 cm)
027503SH	Reflector, Stainless Steel with Hole, 96" (244 cm)
02750800	Reflector End Cap, Aluminum
02750802	Reflector End Cap, Aluminum - EF
027508SS	Reflector End Cap, Stainless Steel
027508SH	Reflector End Cap, Stainless Steel with Hole
02750900	Reflector Joint
02750913	Reflector Joint - EF
027509SS	Reflector Joint, Stainless Steel
027127SS	Reflector Side Extension, Stainless Steel, 96" (244 cm)
03090100	Tube and Reflector Hanger
03090102	Tube and Reflector Hanger - EF
03090103	Tube and Reflector Hanger - EF (Schedule 40 Pipe)
02790300	Tube and Reflector Hanger, Cast Iron
91907302	S-Hook
91903201	Turnbuckle
91903300	Spring Hook, 1/4"
91903301	Spring Hook 3/8" (Schedule 40 Pipe)
91903202	Turnbuckle with Eyebolt
02712100	Universal Shield Support
02751800	Universal Shield with Holes, 96" (244 cm)
02751801	Universal Shield, 96" (244 cm)
027518SS	Universal Shield, Stainless Steel, 96" (244 cm)

Part No.	Description
Control Packages and Accessories	
02770002	CORAYVAC® Heating Control

Part No.	Description
10060001	1 - 3/4 hp, 460V 3Ø VFD
10060002	2 - 3/4 hp, 460V 3Ø VFD's
10060003	1 - 3/4 hp, 1-2 hp, 460V 3Ø VFD
10060004	1 - 2 hp, 460V 3Ø VFD
10060005	2 - 2 hp, 460V 3Ø VFD's
460V3P	Central Controller
10060101	1 - 3/4 hp, 460V 3Ø VFD
10060102	2 - 3/4 hp, 460V 3Ø VFD's
10060103	1 - 3/4 hp, 1-2 hp, 460V 3Ø VFD
10060104	1 - 2 hp, 460V 3Ø VFD
10060105	2 - 2 hp, 460V 3Ø VFD's
460V3P	Satellite Controller
10060111	1 - 3/4 hp, 230V 1Ø VFD
10060112	2 - 3/4 hp, 230V 1Ø VFD's
10060113	1 - 3/4 hp, 1-2 hp, 230V 1Ø VFD
10060114	1 - 2 hp, 230V 1Ø VFD
10060115	2 - 2 hp, 230V 1Ø VFD's
230V 1P	Satellite Controller
10060011	1 - 3/4 hp, 230V 1Ø VFD
10060012	2 - 3/4 hp, 230V 1Ø VFD's
10060013	1 - 3/4 hp, 1-2 hp, 230V 1Ø VFD
10060014	1 - 2 hp, 230V 1Ø VFD
10060015	2 - 2 hp, 230V 1Ø VFD's
230V 1P	Central Controller
10060021	1 - 3/4 hp, 230V 3Ø VFD
10060022	2 - 3/4 hp, 230V 3Ø VFD's
10060023	1 - ¾ hp, 1 - 2 hp, 230v 3Ø VFD's
10060024	1 - 2 hp, 230v 3Ø VFD
10060025	2 - 2 hp, 230v 3Ø VFD's
02750313	Barrier Shield, (High Efficiency Reflector) 96" (244 cm)
230V 3P	Central Controller
10060121	1 - 3/4 hp, 230V 3Ø VFD
10060122	2 - 3/4 hp, 230V 3Ø VFD's
10060123	1 - 3/4hp, 1 - 2 hp, 230v 3Ø VFD's
10060124	1 - 2 hp, 230v 3Ø VFD
10060125	2 - 2 hp, 230v 3Ø VFD's
115V1P	Satellite Controller
10060031	1 - 3/4 hp, 115V 3Ø VFD
10060032	2 - 3/4 hp, 115V 3Ø VFD
CRV ON/OFF	
10060042	CRV On/Off 4 Zone 2 Pumps Control - Central
10060142	CRV On/Off 4 Zone 2 Pumps Control - Satellite
Additional Part Numbers	
10061003	Indoor Sensor
10081501	Outdoor Sensor
Part No.	Description
05023000	Load Relay Package
90436300	Transformer Relay - DPDT (12 A)
90423000	24 V Low Voltage Thermostat
90424300	Thermostat Guard
Part No.	Description
90425105	Thermostat, Modulating
Part No.	Description
Deco Grille (2' x 4' [.6 m x 1.2 m])	
01365900	Shield Frame
01370408	Reflector Side Extension 8" x 48" (20.3 cm x 122 cm)
01370412	Reflector Side Extension 12" x 48" (30.5 cm x 122 cm)
01370416	Reflector Side Extension 16" x 48" (40.6 cm 122 cm)
91407000	Grille, Aluminum 2' x 4' (.6 m x 1.2 m)
Part No.	Description
Protective Grille	
08050001	Protective Grille, 40" (1 m) (Standard Reflector Only)
08050002	Protective Grille End Cap (Standard Reflector Only)
08050003	Protective Grille, 40" (1 m) (High Efficiency Reflector Only)
08050004	Protective Grille End Cap (High Efficiency Reflector Only)
Part No.	Description
Shields	
02750303	Barrier Shield, (Standard Reflector) 96" (244 cm)
02751801	Universal Shield, 96" (244 cm)
027518SS	Universal Shield, Stainless Steel, 96" (244 cm)
02751800	Universal Shield with Holes, 96" (244 cm)
Part No.	Description
Pump Packages	
02719105	EP-100 Pump Package
02716305	EP-201 Pump Package
02712034	EP-203 Pump Package
02723014	EP-301 Pump Package 4"
02723016	EP-301 Pump Package 6"
02723034	EP-303 Pump Package 4"
02723036	EP-303 Pump Package 6"
Part No.	Description
Pump Accessories	
90430600K	Pressure Switch
01327001	Condensate Check Valve Assembly
02718851	Drain Cap, 4" (10 cm)
02718852	Drain Cap, 6" (15 cm)
01327006	Condensate Neutralization Tube 1500
01327005	Condensate Neutralization Tube 2000
Part No.	Description
Contactors	
10050011	Contactors Package (17 amps), 120 Vac for EP-203, EP-303, 3 Ø EP-100, EP-201 208/230 V, 1 Ø EP-301 208/230 V, 1 Ø
10050012	Contactors Package (28 amps), 120 Vac for EP-301, 120 V, 1 Ø

SECTION 6: DESIGN REQUIREMENTS

The CRV-Series system's design is related to the system operation and performance required by the building being heated. Every effort should be made to follow the dimensions on the layout drawing. If deviations are necessary, either contact the company responsible for the layout design, your ROBERTS GORDON® independent distributor, or consult the CRV-Series Design Manual (P/N 127500NA).

FIGURE 19: Heater Assembly Overview

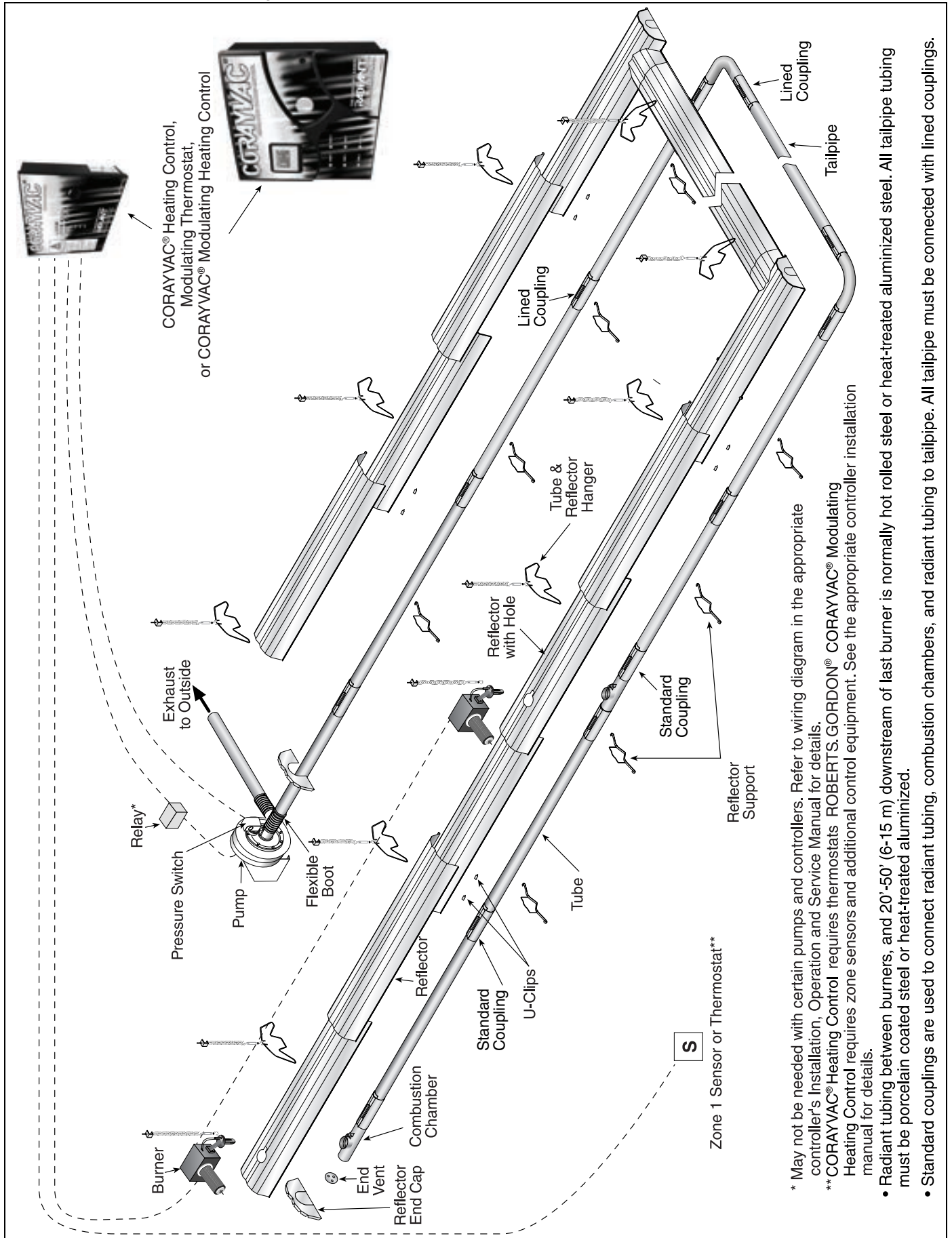

- * May not be needed with certain pumps and controllers. Refer to wiring diagram in the appropriate controller's Installation, Operation and Service Manual for details.
- ** CORAYVAC® Heating Control requires thermostats ROBERTS.GORDON® CORAYVAC® Modulating Heating Control requires zone sensors and additional control equipment. See the appropriate controller installation manual for details.
- Radiant tubing between burners, and 20'-50' (6-15 m) downstream of last burner is normally hot rolled steel or heat-treated aluminized steel. All tailpipe tubing must be porcelain coated steel or heat-treated aluminized.
- Standard couplings are used to connect radiant tubing, combustion chambers, and radiant tubing to tailpipe. All tailpipe must be connected with lined couplings.

SECTION 7: HEATER INSTALLATION

⚠ WARNING



Severe Injury Hazard
Standard CORAYVAC® Systems

Secure burner to combustion chamber with nuts and lockwashers.

Hang heater with materials with a minimum working load of 75 lbs (33 kg).

Failure to follow these instructions can result in death, injury or property damage.

⚠ WARNING



Severe Injury Hazard
CORAYVAC® Classic Systems

Hang heater with materials with a minimum working load of 750 lbs. (340 kg).

Use special tube and reflector hangers when suspending the schedule 40 steel pipe system.

Schedule 40 steel pipe is heavy and will fall if not supported properly.

Distance between supports must be 7'-6" (2.13 m) or less.

Failure to follow these instructions can result in death, injury or property damage.

⚠ WARNING



Cut/Pinch Hazard

Wear protective gear during installation, operation and service.

Edges are sharp.

Failure to follow these instructions can result in injury.

To ensure your safety and comply with the terms of the warranty, all units must be installed in accordance with these instructions.

The gas or the electrical supply lines must not be used to support the heater.

Do not locate the gas or electric supply lines directly over the path of the flue products from the heater.

The heater must be installed in a location that is readily accessible for servicing.

The heaters must be installed in accordance with clearances to combustibles as indicated on the rating plate and in this instruction manual.

The minimum and maximum gas inlet pressures must be maintained as indicated on the rating plate.

Typical installation configurations are shown on Page 21, Figure 20.

Expansion and contraction of the tube dictates that the minimum suspension lengths must be maintained. See table on Page 21, Figure 20.

FIGURE 20: Critical Hanger Placement

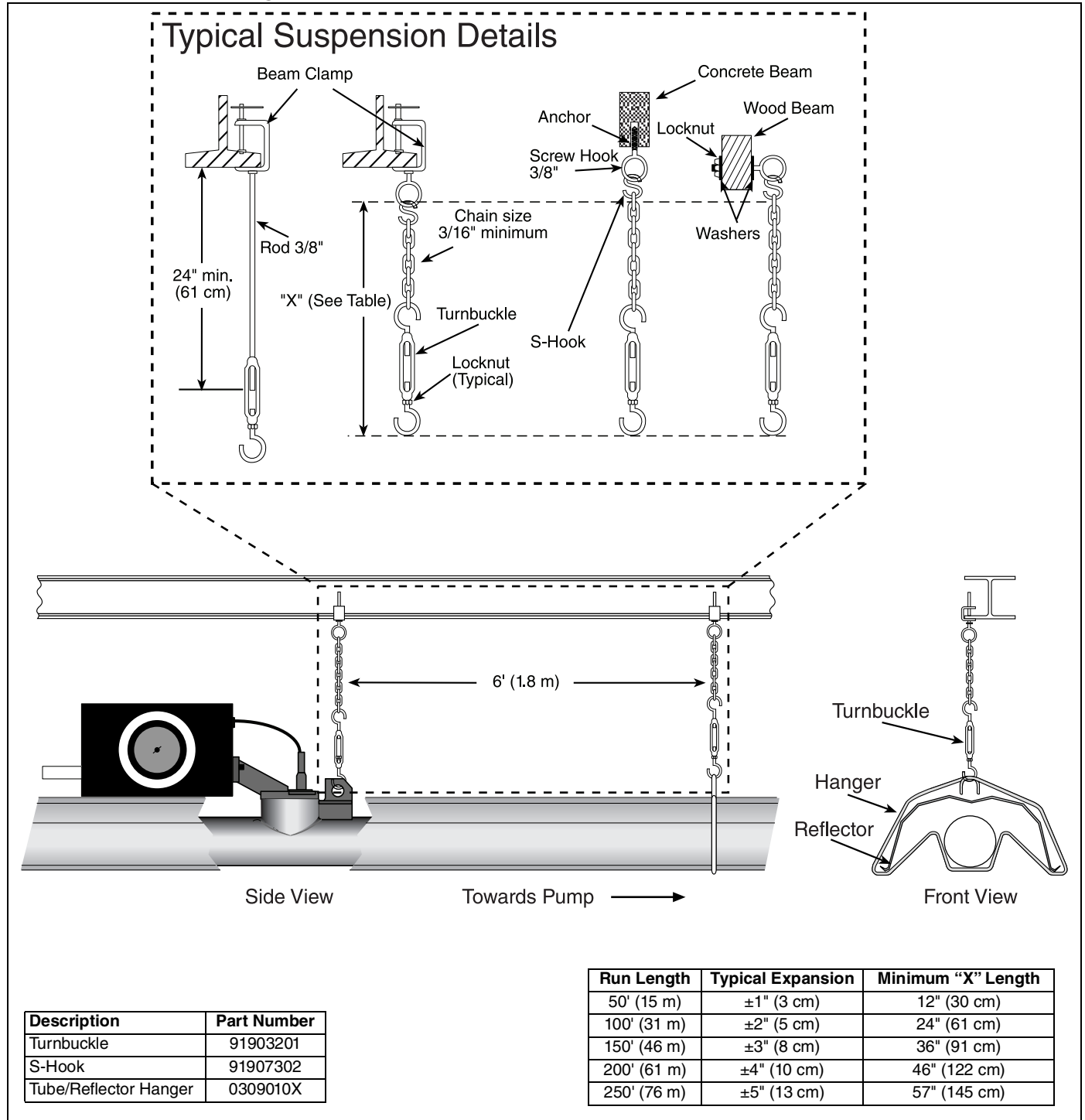
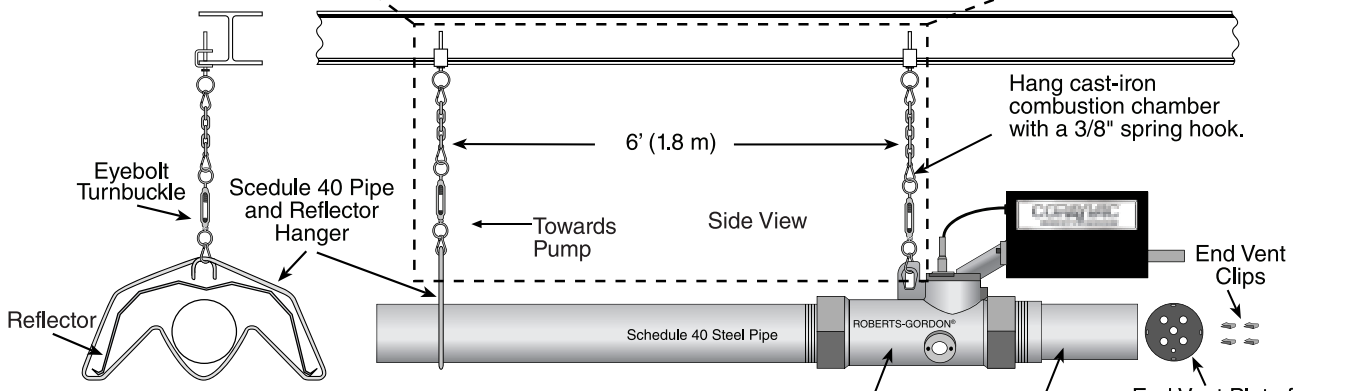
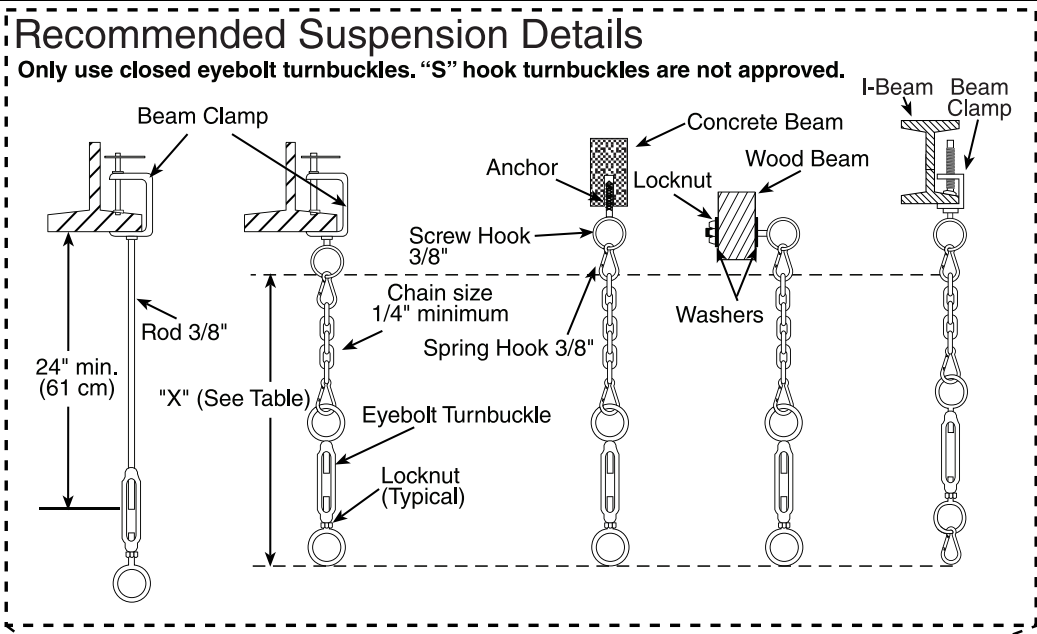
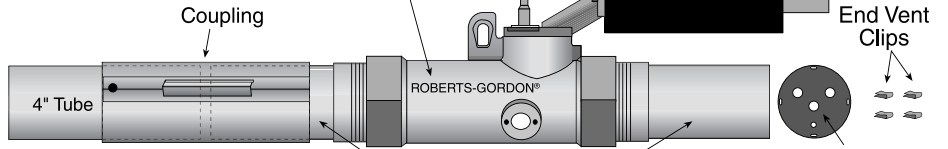

FIGURE 21: Critical Hanger Placement (CORAYVAC® Classic)



Cast-Iron Combustion Chamber with Schedule 40 Steel Pipe
 The total weight of each burner and combustion chamber is 40.25 lbs (18 kg).
 4" Schedule 40 pipe weighs 10.9 lbs. (5 kg) per foot.



Cast-Iron Combustion Chamber with Standard 4" O.D. Infrared Tubing
 The total weight of each burner and combustion chamber is 40.25 lbs (18 kg).
 4" O.D. 16 Ga. tubing weighs 2.8 lbs. (1.3 kg) per foot.

Description	Part Number
Eyebolt Turnbuckle	91903202
Spring Hook 3/8"	91903301
Tube/Reflector Hanger, Schedule 40 Pipe	02790300
Tube and Reflector Hanger - EF (Schedule 40 Pipe)	03090103
Cast-Iron Combustion Chamber	02721200-1P
Cast-Iron Adapter	02722100

Run Length	Typical Expansion	Minimum "X" Length
50' (15 m)	±1" (3 cm)	12" (30 cm)
100' (31 m)	±2" (5 cm)	24" (61 cm)
150' (46 m)	±3" (8 cm)	36" (91 cm)
200' (61 m)	±4" (10 cm)	46" (122 cm)
250' (76 m)	±5" (13 cm)	57" (145 cm)

Step 7.1 Tube Installation

NOTE: Tubing requires a downward slope of 1/2" (13 mm) per 20' (6 m) away from burner. Tailpipe tubing requires a downward slope of 1" (26 mm) per 20' (6 m) away from burner.

Note: CORAYVAC® Classic systems require all hangers after the first hanger to be positioned a maximum of 7' (2.1 m) apart.

Description	Part Number
Tube	91409XXX
Turnbuckle	91903201
Tube/Reflector Hanger	0309010X

Step 7.2 Coupling and Tube Assembly

A Close coupling and slide opposite end into tab. Position tab underneath guide rail.

Open Coupling
Guide Rail
Closed Coupling
Tab

B Insert wide end of slide bar/coupling lock into guide rail on opposite end of tabs. Slide the slide bar/coupling lock up the guide rail until snug (approximately 3" (8 cm) to 4" (10 cm)).

Slide Bar/Coupling Lock
Wide End Guide Rail
3" (8 cm) to 4" (10 cm)

C Insert tubes into coupling until end of each tube rests against internal pins.

Internal Pins
Tube
Tube
Coupling End View
Align coupling so that side bar/coupling lock is rotated to the 2:00 or 10:00 o'clock position.

D Strike slide bar/coupling lock with mallet or hammer until tight.

Slide Bar/Coupling Lock
Coupling
Tube

Description	Part Number
Coupling	01329600
Slide Bar/Coupling Lock	01329700
Tube	91409XXX

Step 7.2.1 Coupling and Tube Assembly (Continued)

Tighten slide bar as shown below.

Be sure not to over tighten slide bar/coupling lock. Slide bar/coupling lock should be within tolerance listed below.

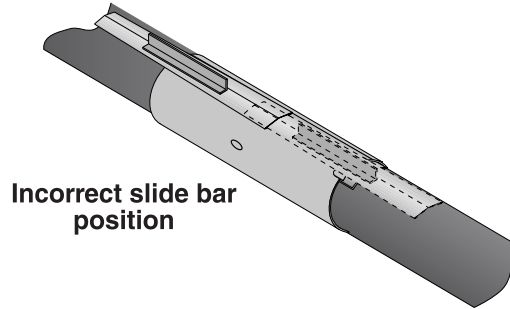
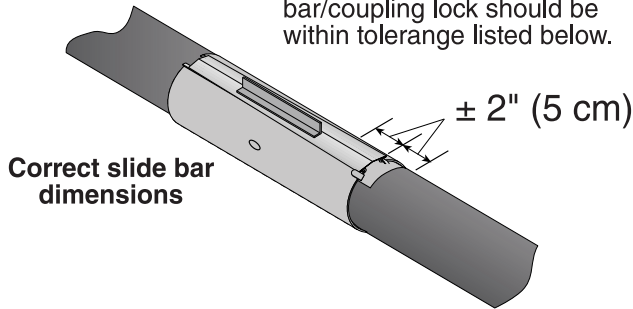

Note: If coupling is not tight, loss of vacuum can occur.

• Repeat Step 7.2 A - D until all tubes are assembled. See Page 25, Step 7.3.

Note: Standard couplings (P/N 01312700) are used to connect radiant tubing, combustion chambers, and radiant tubing to tailpipe. All tailpipe must be connected with lined couplings (P/N 01312701). Lined couplings can be identified by the thin layer of sheet metal attached to the inner portion of the coupling.

Step 7.2.2 Elbow Installation

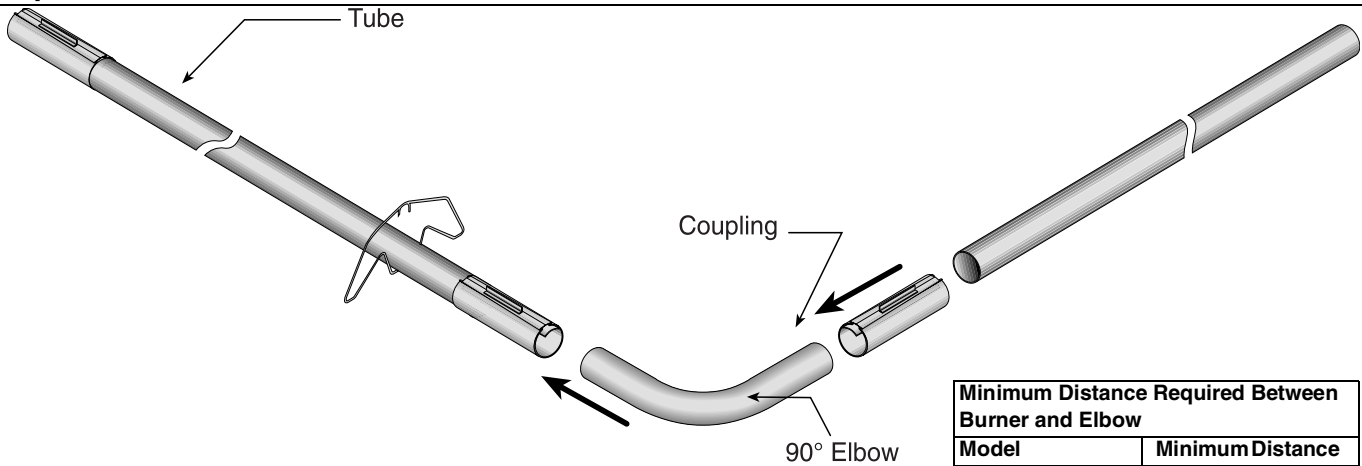

Description	Part Number
Elbow Package	0271870X
90° Elbow	01335801
Coupling	01312700
Reflector End Cap	0275080X
Reflector Joint Piece	0275090XS
U-Clip Package	91107720

Minimum Distance Required Between Burner and Elbow	
Model	Minimum Distance
CRVB-2	5' (1.5 m)
CRVB-4	5' (1.5 m)
CRVB-6	10' (3 m)
CRVB-8	10' (3 m)
CRVB-9	10' (3 m)
CRVB-10	15' (4.5 m)
CRVB-12A	15' (4.5 m)
CRVB-12	15' (4.5 m)

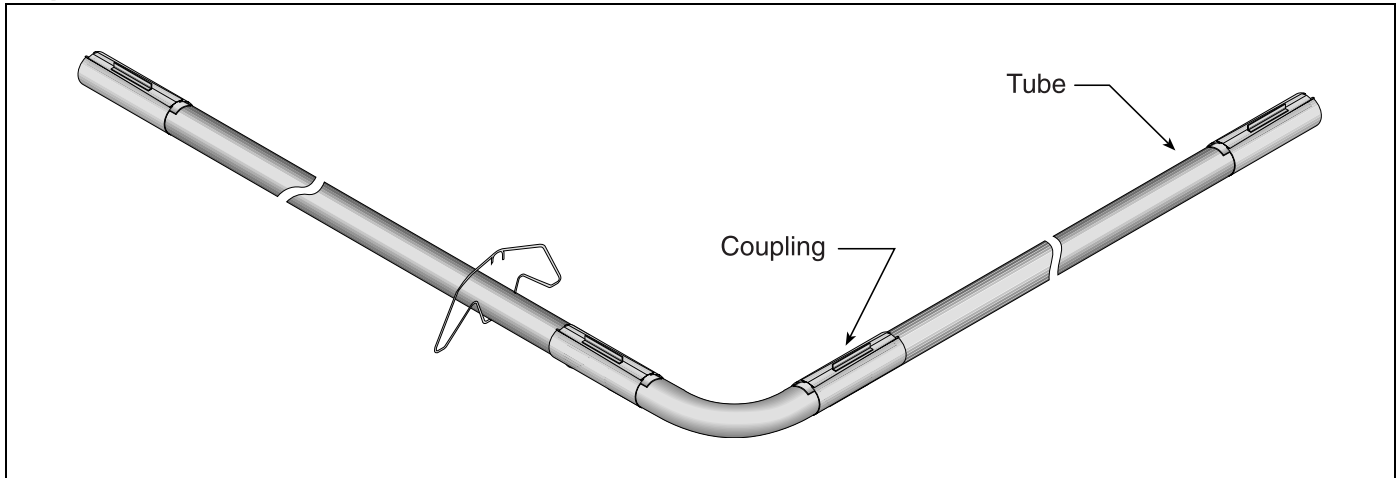
Step 7.2.3 Elbow Installation**Step 7.3 Reflector Installation**

⚠ WARNING

Fire Hazard
Support reflector with reflector hanger and support strap.
Reflector must not touch tube.
Failure to follow these instructions can result in death, injury or property damage.

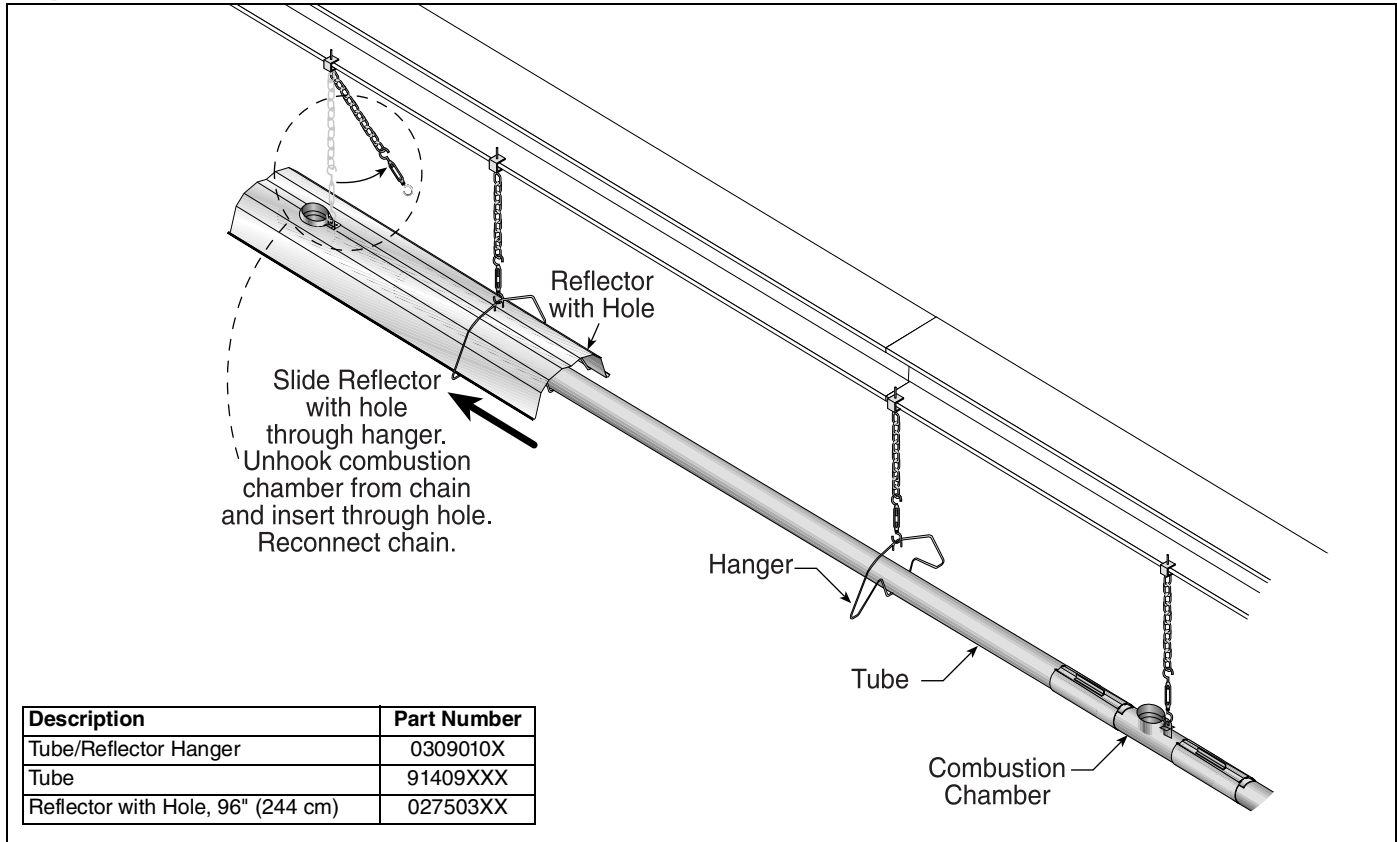
Step 7.3.1 Reflector Installation with Hole

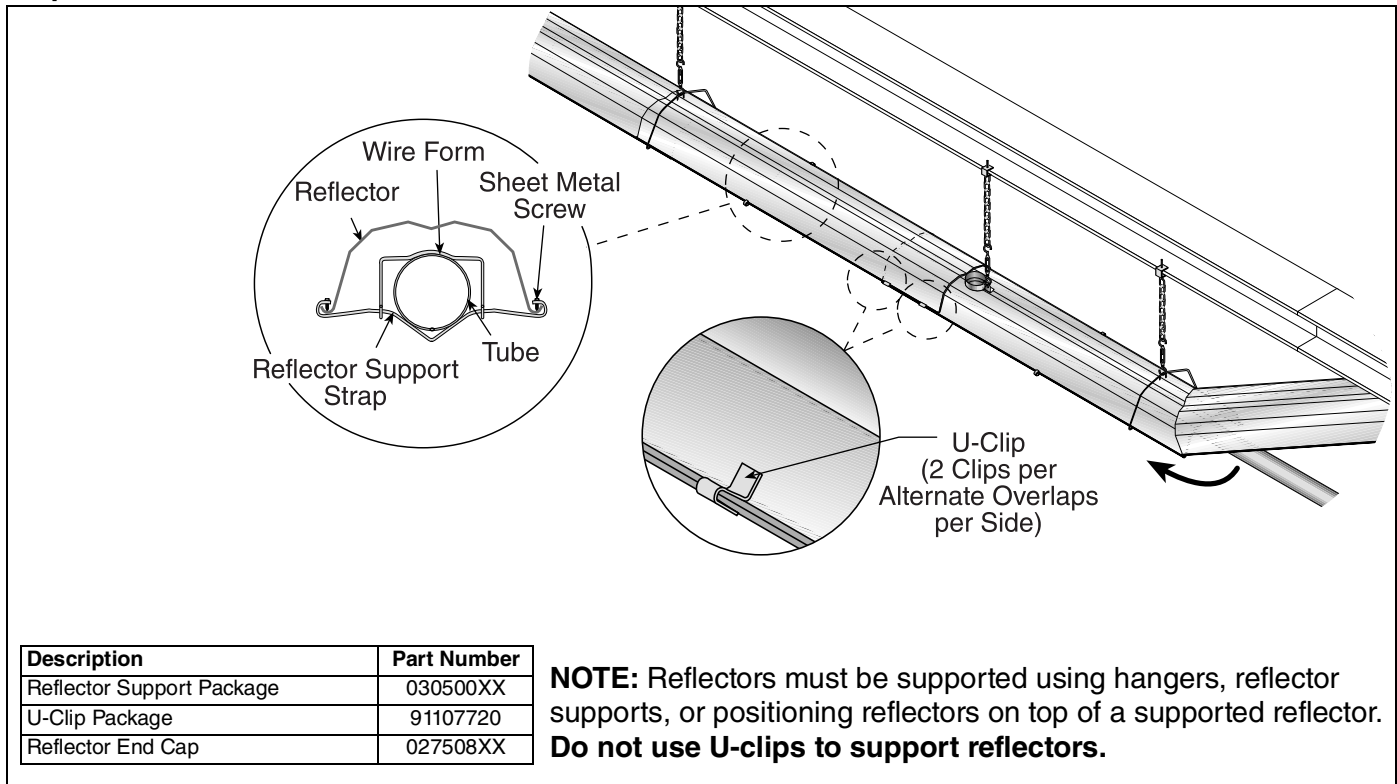

Step 7.3.2 Reflector Installation



Step 7.3.3 Reflector, U-Clip and Reflector Support Installation

The pictorial drawings of the heater construction in *Section 7* are schematic only and provide a general guideline of where hangers, reflector supports and U-clips are to be installed.

To ensure proper expansion and contraction movement of the reflectors, a combination of U-clips and reflector supports are used. The positioning of

reflector supports and U-clips depend on the individual installation. Use either pop rivets or sheet metal screws instead of u-clips when installing end caps and joint pieces in areas where impact and high wind may be a factor. The following rules must be observed.

1. The first reflector after the burner must be affixed in the middle of the reflector with a reflector support and tight screws.

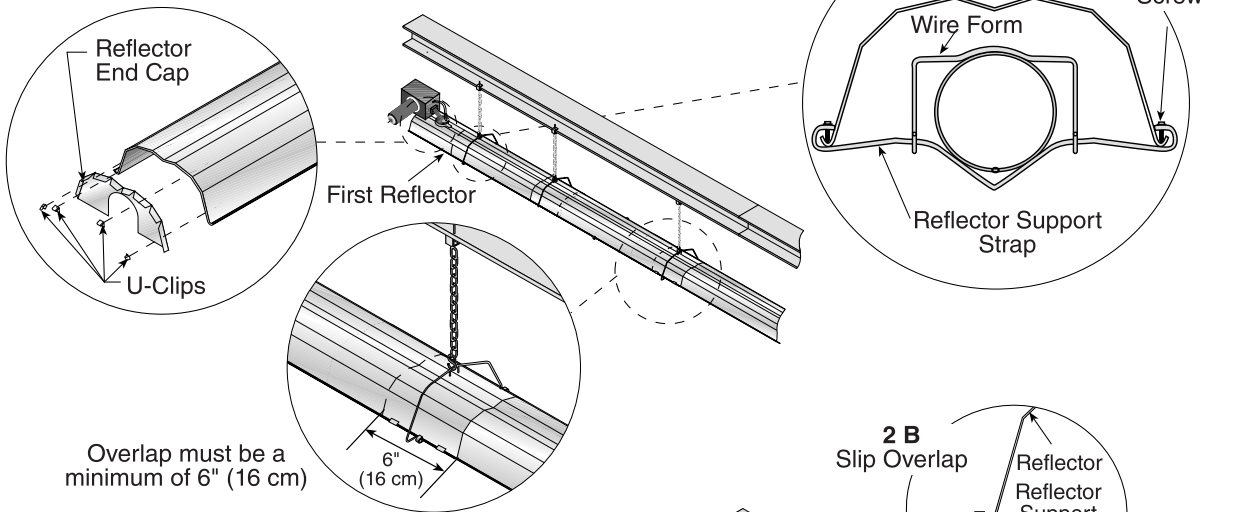

Overlap must be a minimum of 6" (16 cm)

Note: For proper reflector support, the reflector with hole is placed underneath the second reflector.

2. The overlap at the first and second reflector is a **slip overlap**. Thereafter, every third reflector joint is a slip overlap. A slip overlap is achieved by either:
 - a.) both reflectors lay inside a hanger. (No reflector support needed).
 - b.) using a reflector support with loose screws at the reflector overlap.

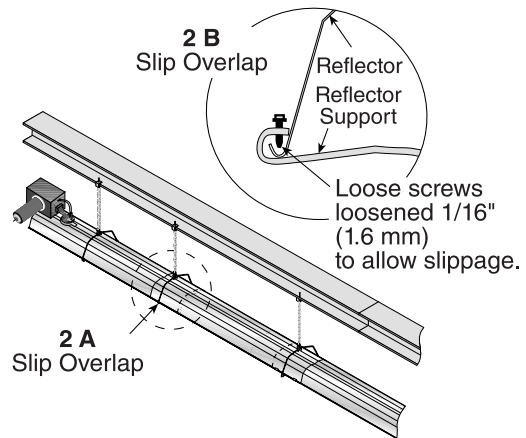

3. The remaining reflector overlaps require a **non-slip overlap connection**. To affix the reflectors together in a non-slip overlap either:
 - a.) use reflector support and tight screws.
 - b.) if both reflectors lay inside a hanger, u-clips or sheet metal screws may be used.

This section of three reflectors joined together must be affixed to the tube with at least one reflector support with tight screws.

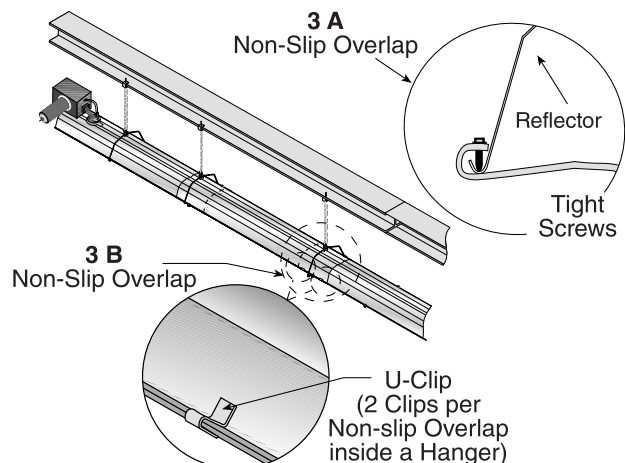

Description	Part Number
Reflector Support Package	030500XX
Wire Form	91908004
Reflector Support Strap	0305000X
Screw #8 x 3/4	94320812
U-Clip Package	91107720
Reflector End Cap	027508XX

Step 7.4 Burner Installation

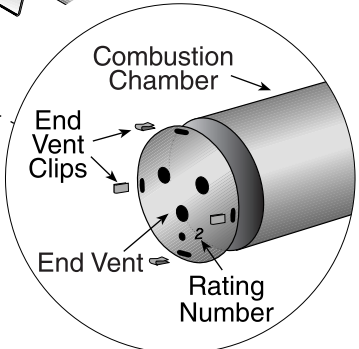
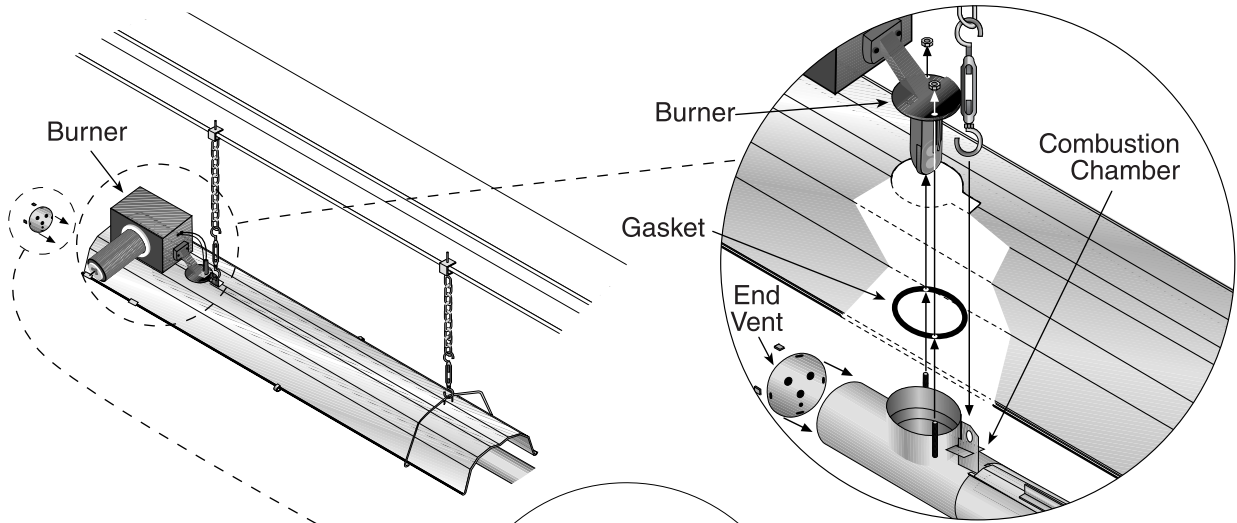

NOTE:
Install end vent
at end combustion
chamber position only.

Description	Part Number
Bolt	94273914
Burner	0270XXX
Lock Washer	96411600
Gasket	01367800
End Vent	013676XX

SECTION 8: OPTIONAL HEATER ACCESSORIES

! WARNING

Cut/Pinch Hazard
Wear protective gear during installation, operation and service.
Edges are sharp.
Failure to follow these instructions can result in injury.

8.1 U-Tube Configuration

When using a U-tube configuration, the following additional rules must be adhered to:

Note: Reflectors must be supported using hangers, reflector supports, or positioning reflectors on top of a supported reflector. Do not use U-clips to support reflectors.

- The heater must be properly supported at all locations. See *Page 30, Figure 22*.

NOTE: Minimum distance required between burner and U-tube: 5' (1.5 m) on CRV-B-2/4, 10' (3 M) on CRV-B-6/8/9, 15' (4.5 m) on CRV-B-10/12A/12.

FIGURE 22: U-Tube Heater Assembly Overview

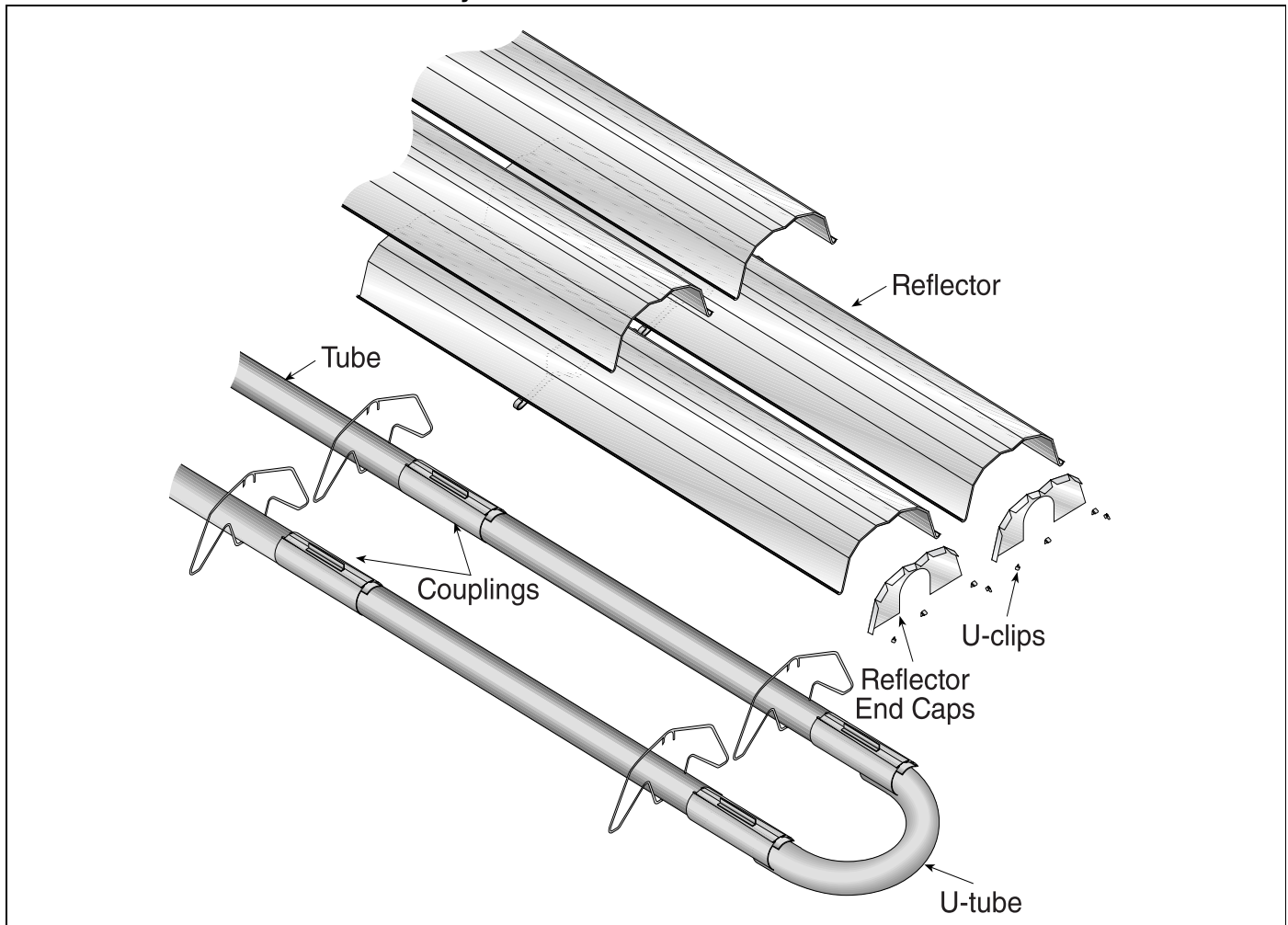

Step 8.2 Tee Installation

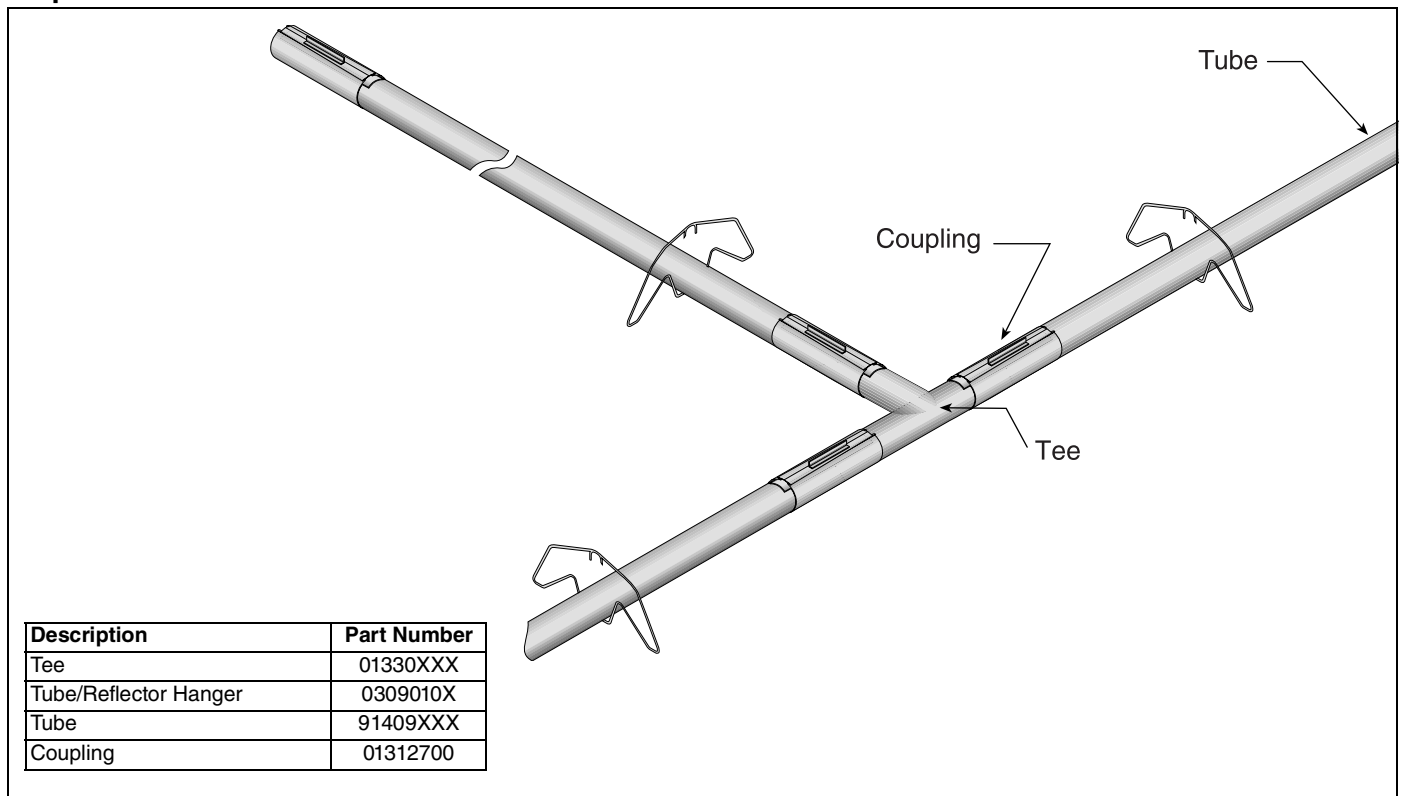

Description	Part Number
Tee	01330XXX
Tube/Reflector Hanger	0309010X
Tube	91409XXX
Coupling	01312700

Step 8.3 Reflector Joint

Step 8.3.1 Reflector Joint Installation

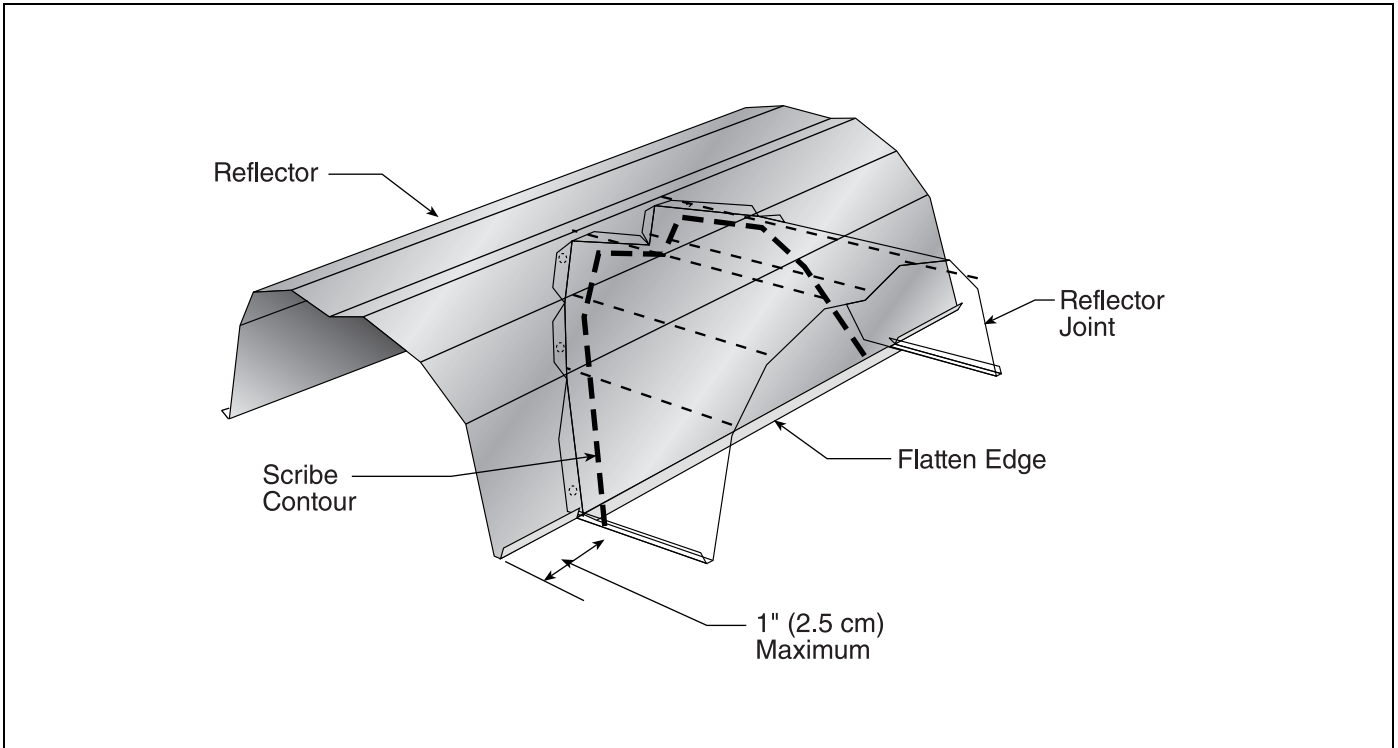

Step 8.3.2 Reflector Joint Installation

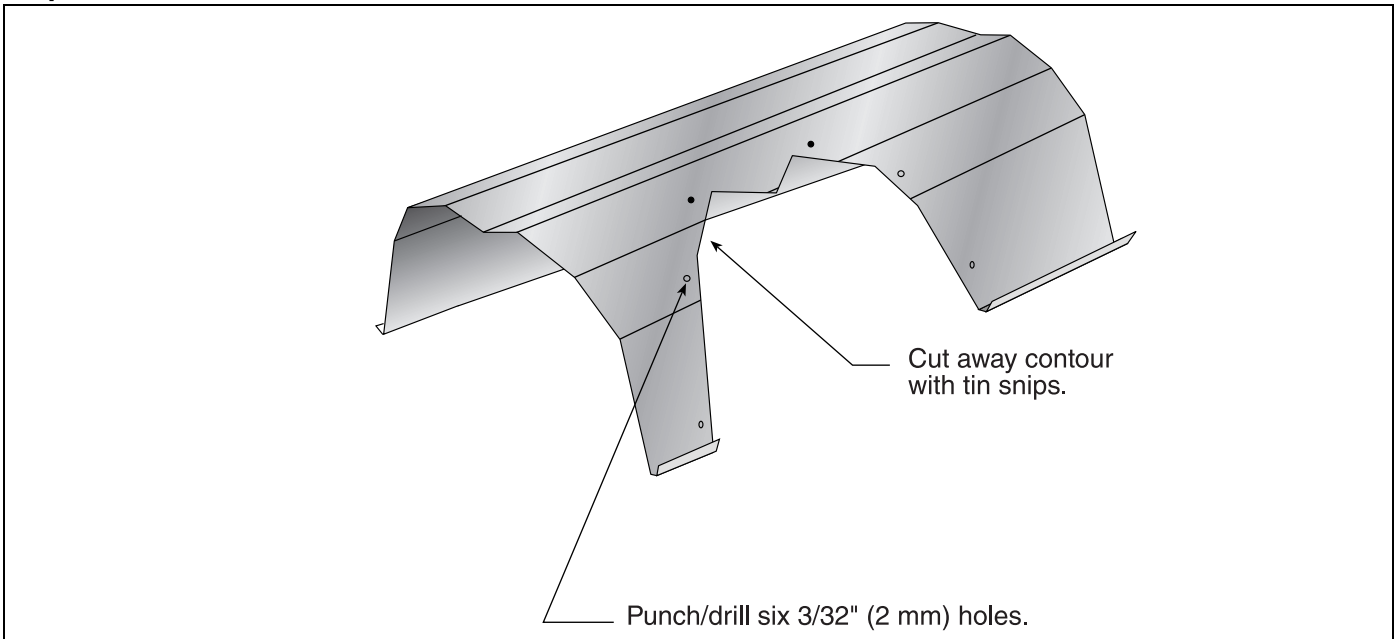

Step 8.3.3 Reflector Joint Detail

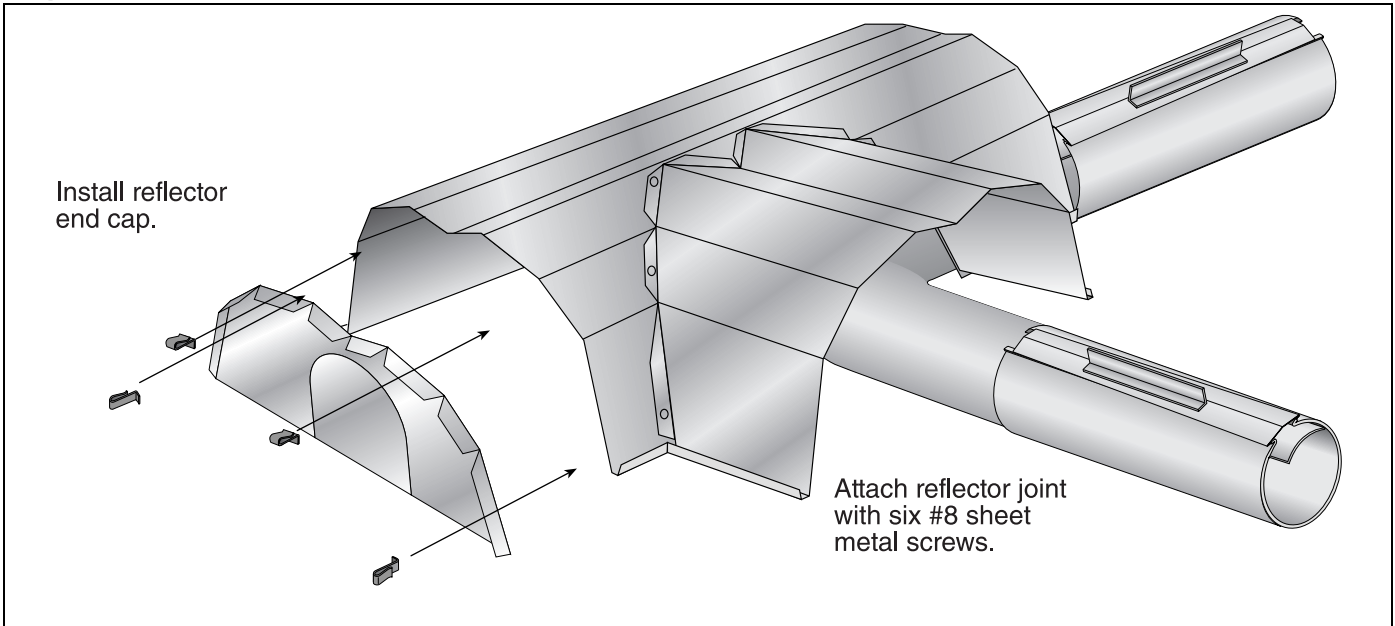
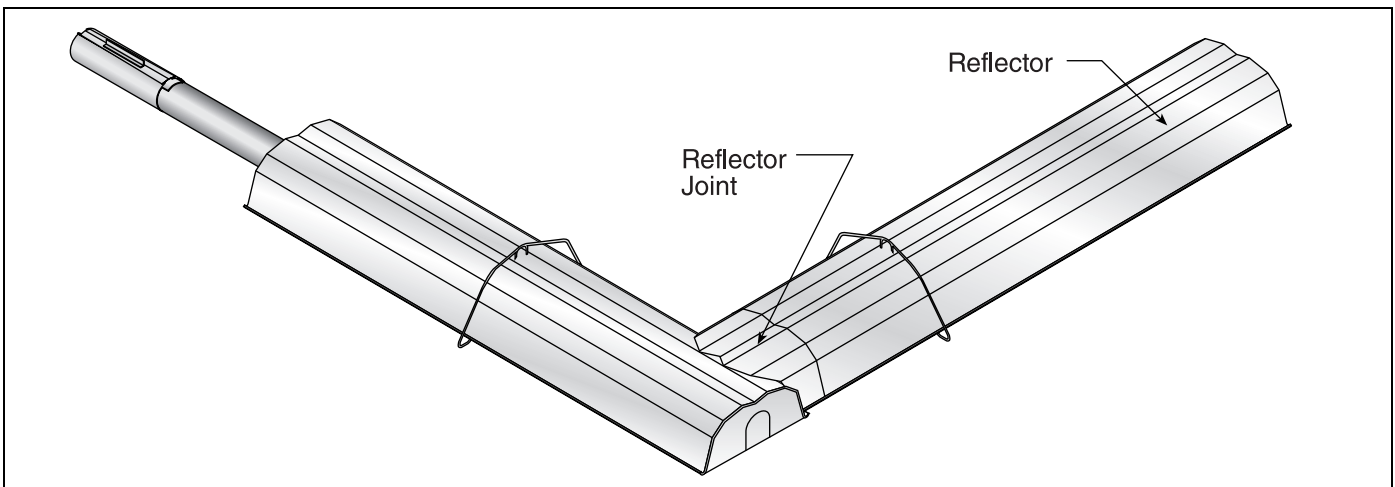
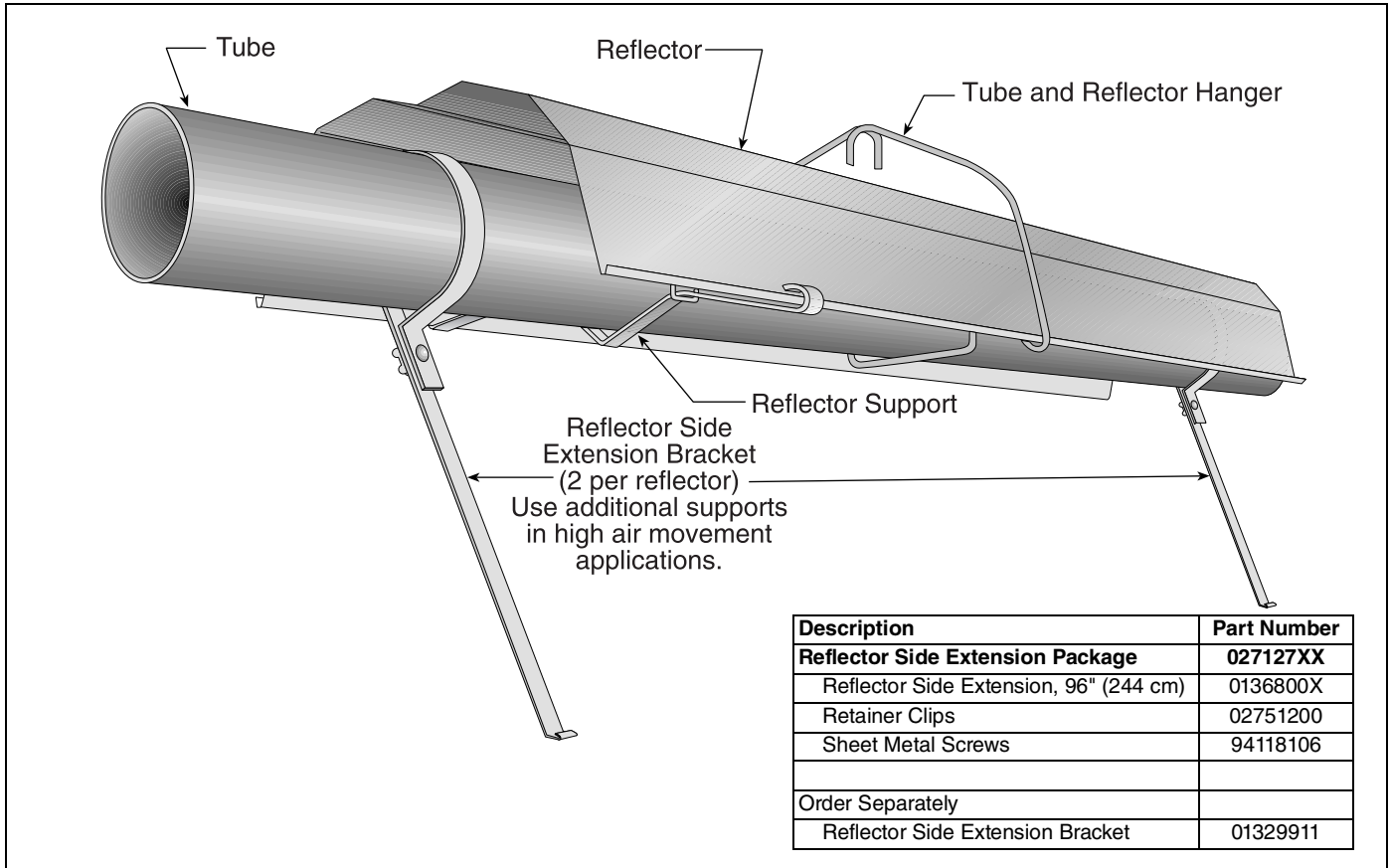

FIGURE 23: Reflector Joint Detail



8.4 Reflector Side Extension

Step 8.4.1 Bracket Installation



Step 8.4.2 Side Reflector Installation

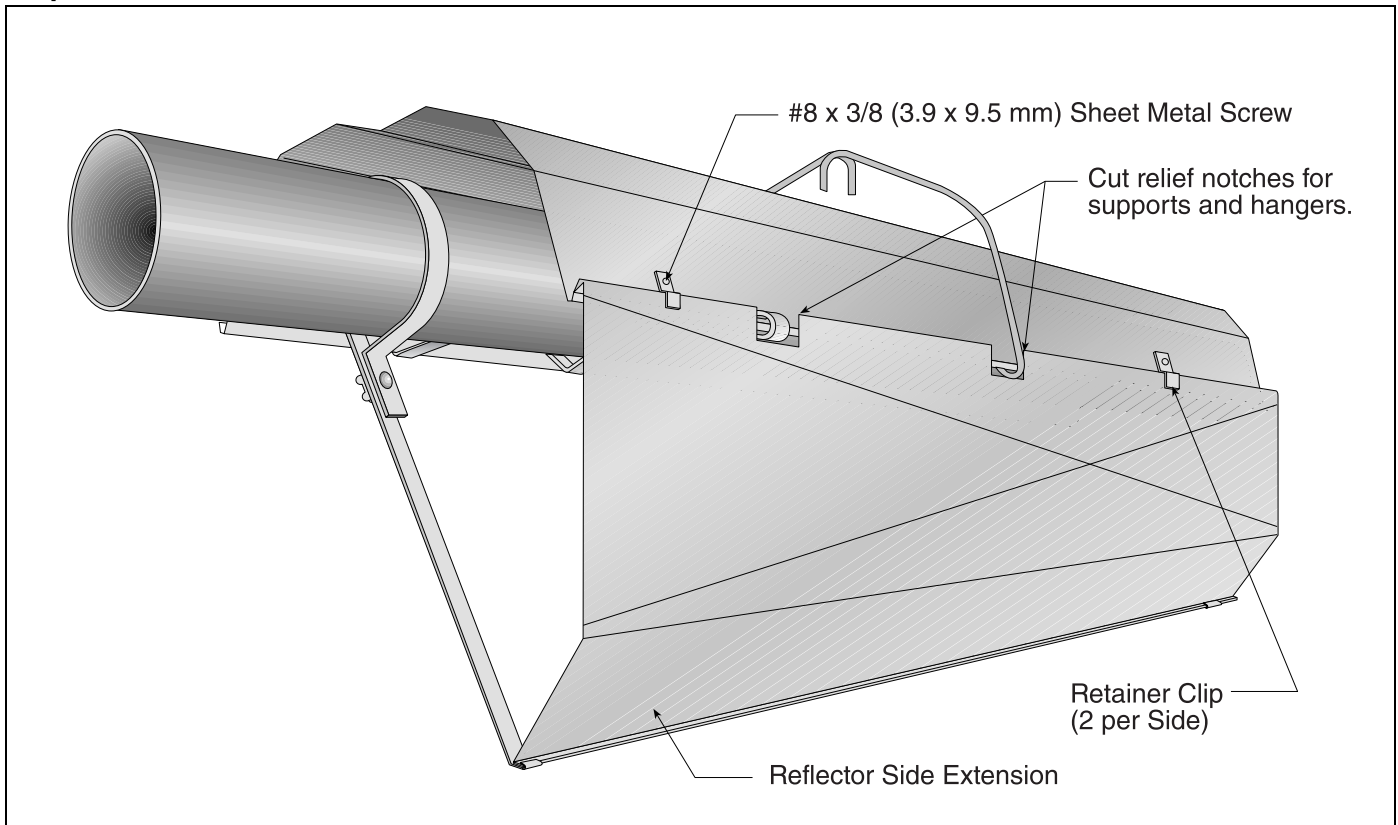

8.5 Universal Shield

Universal shields are adjustable aluminum reflectors whose angle and height can be adjusted to direct heat to or away from a desired area. See Page 7, Figure 6 through Page 7, Figure 8 for positions.

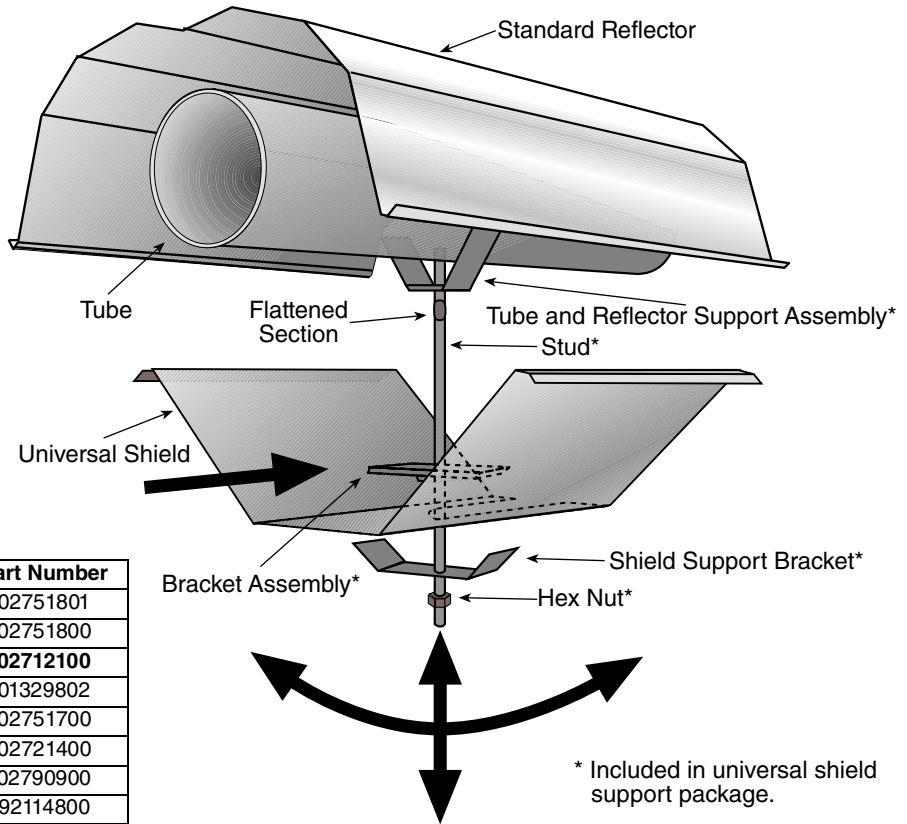

Description	Part Number
Universal Shield	02751801
Universal Shield with Holes	02751800
Universal Shield Support Package	02712100
Tube and Reflector Support Assembly	01329802
Universal Shield Support	02751700
Shield Bracket Assembly	02721400
Stud	02790900
Hex Nut	92114800

* Included in universal shield support package.

8.6 Barrier Shield

Do not install barrier shield less than 20' (6 m) downstream of any burner. Do not attach end caps to the ends of the barrier shields. For lengths greater than 8' (2.6 m), use universal shields. Barrier shield must be cut down to 4' (1.2 m) sections if used with burners larger than 80,000 Btu/h. Do not install more than 1 barrier shield in between in-series burners larger than 80,000 Btu/h.

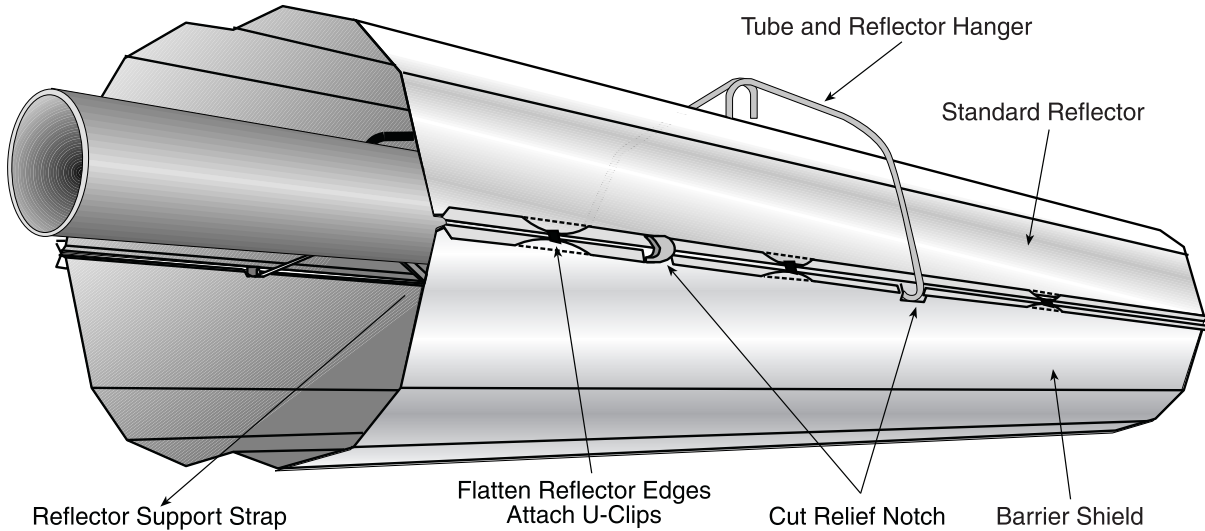

Description	Part Number
Barrier Shield, (Standard Reflector) 96" (244 cm)	027503XX
U-Clip Package	91107720

8.7 Two-Foot Decorative Grille Installation

Step 8.7.1 Grille Installation

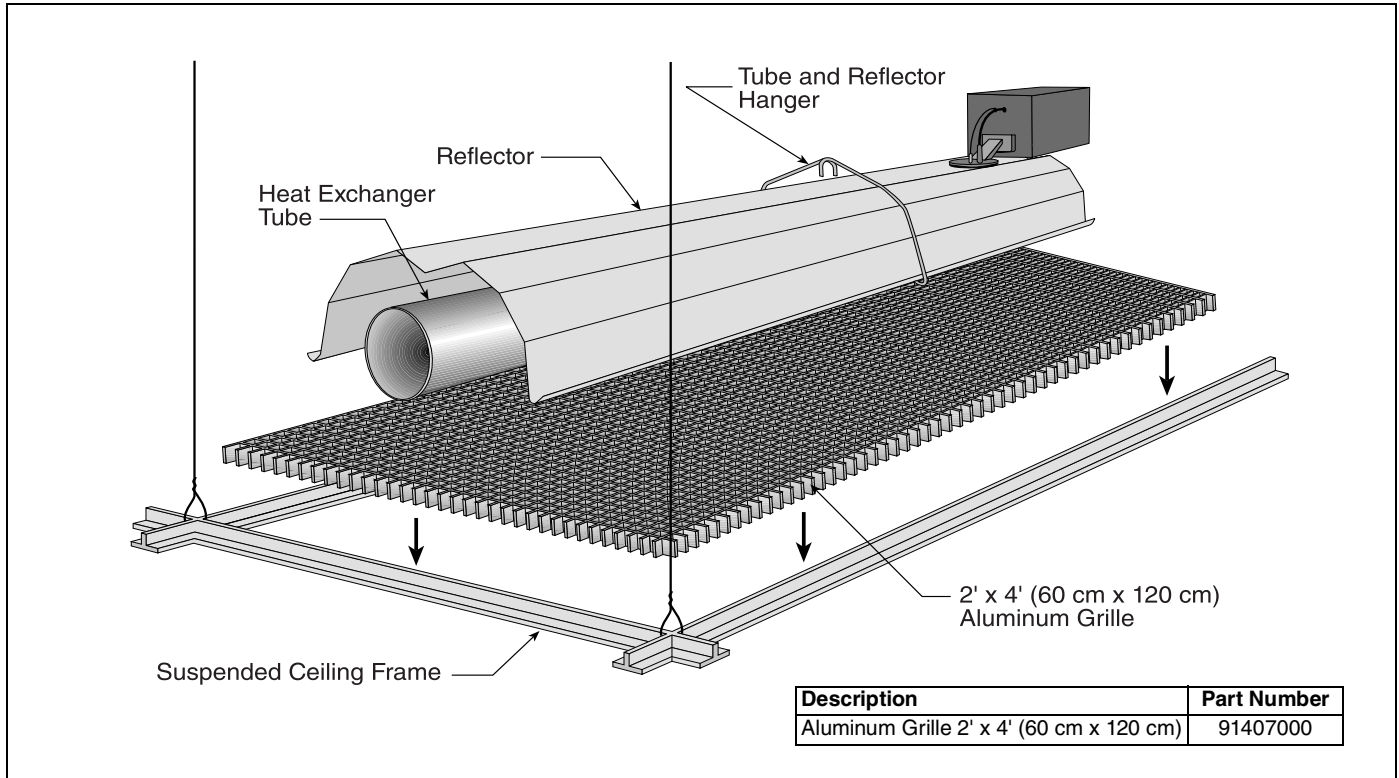

Step 8.7.2 Frame Shield Installation

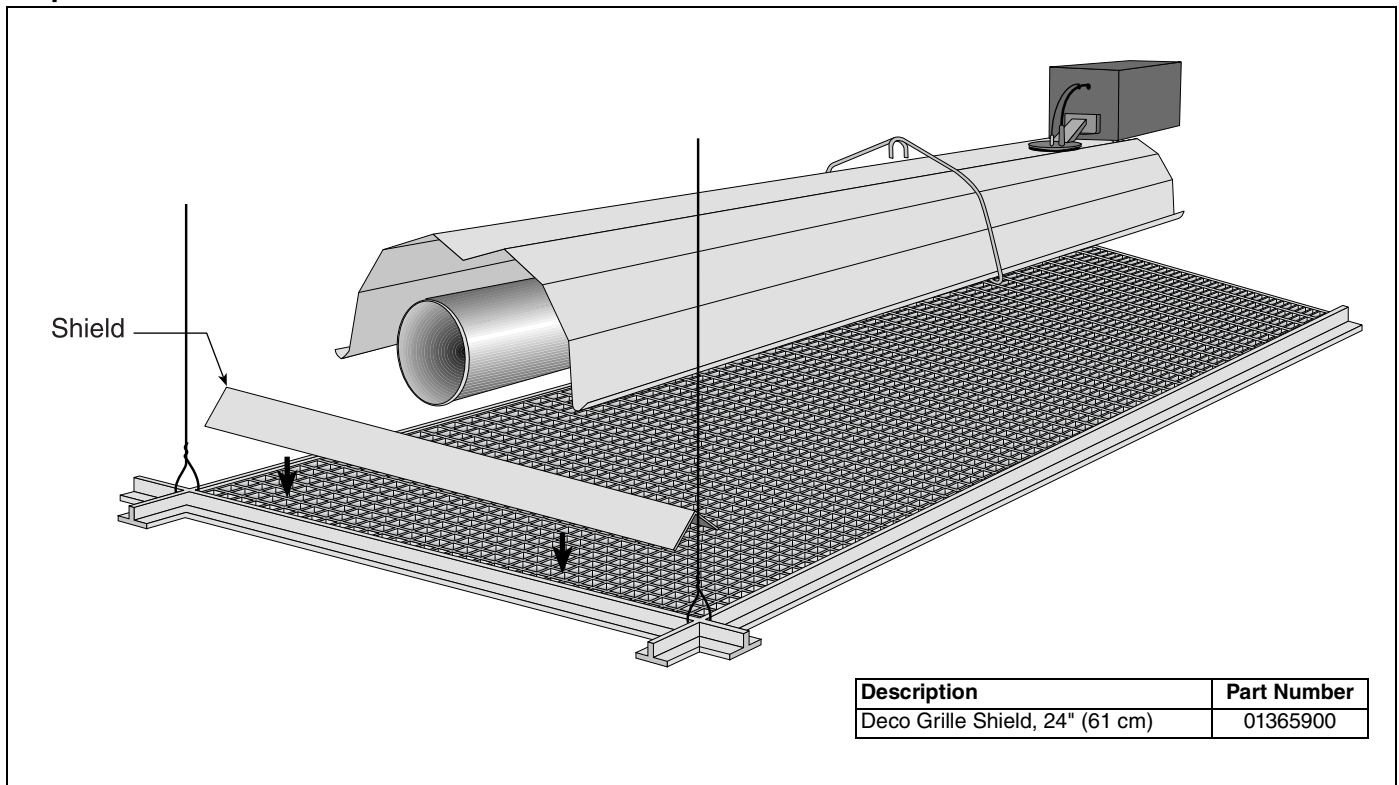

Step 8.7.3 Reflector Side Extension Installation for Decorative Grilles

NOTE: If the decorative grille system is to be installed in an area with considerable air movement, it is recommended that one #8 x 3/8" sheet metal screw be installed per reflector extension to prevent it from blowing over.

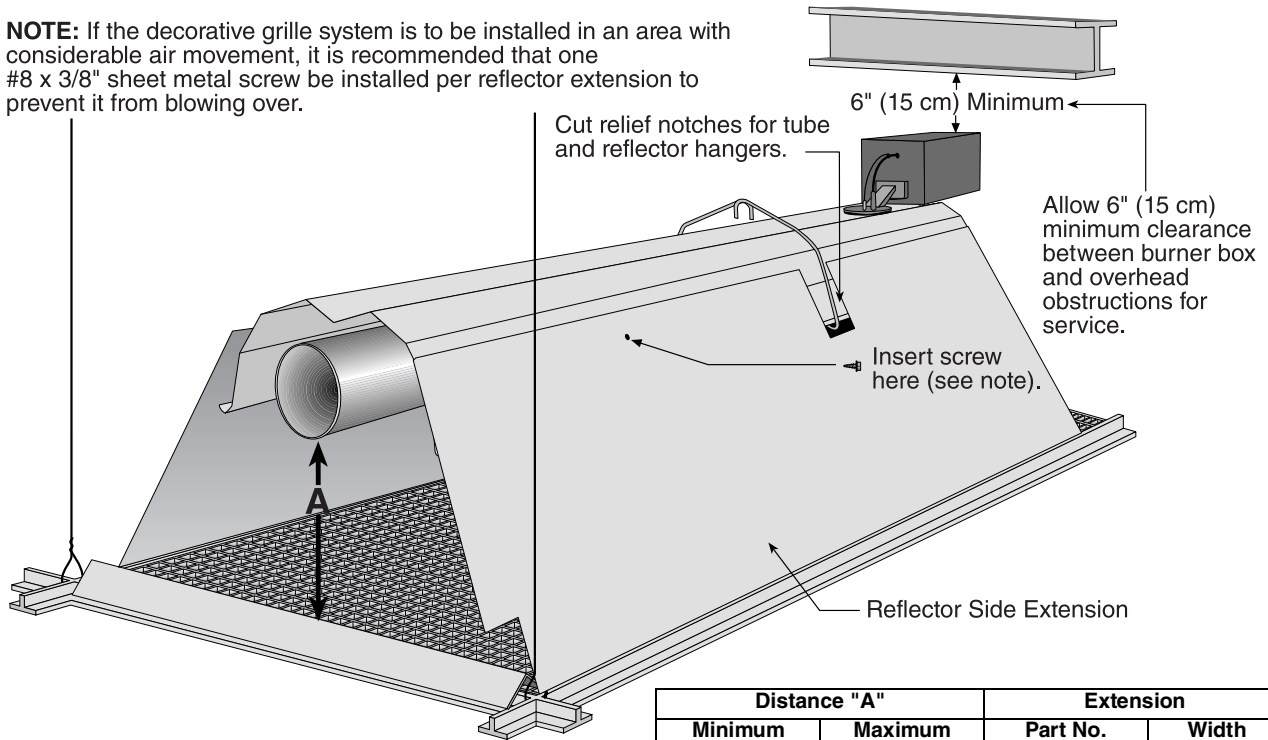

Description	Part Number
Reflector Side Extension, 48" (122 cm)	013704XX

Distance "A"		Extension	
Minimum	Maximum	Part No.	Width
2" (4 cm)	6" (15 cm)	013704XX	8" (20 cm)
6" (15 cm)	10" (26 cm)	013704XX	12" (30 cm)
10" (26 cm)	14" (37 cm)	013704XX	16" (40 cm)

8.8 Protective Grille Installation

Step 8.8.1 Silicone Cap Installation

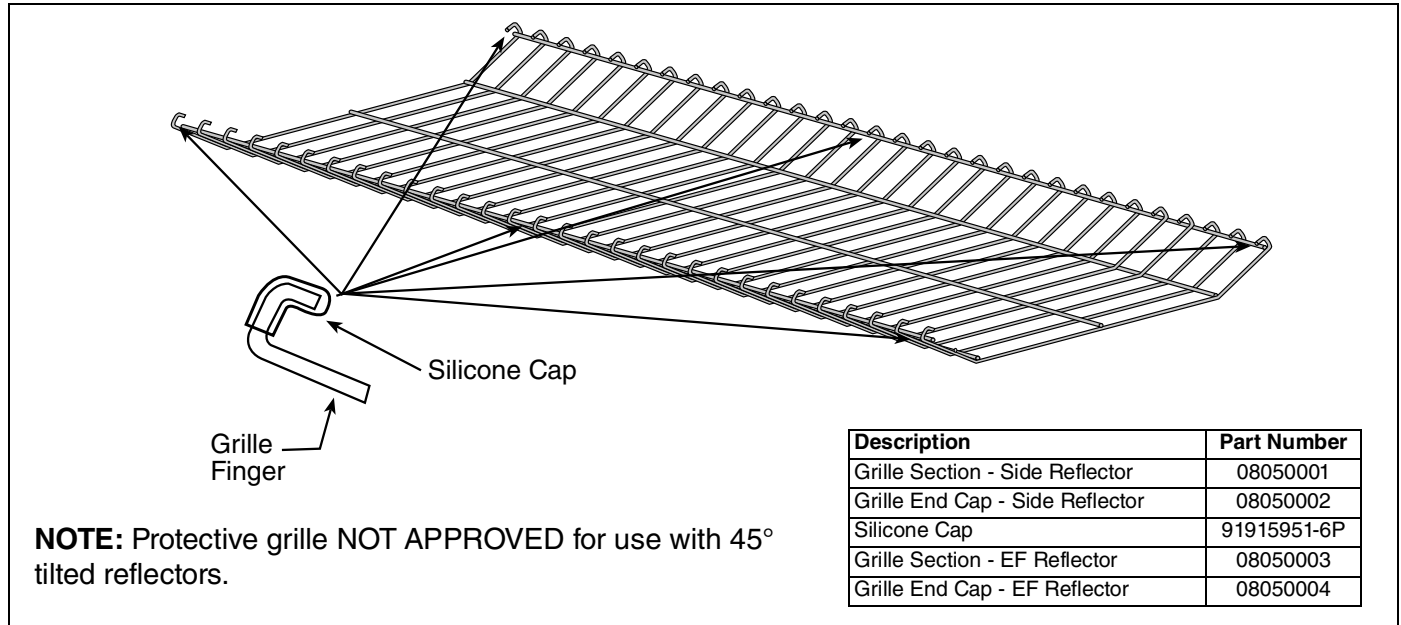

Step 8.8.2 Grille End Cap Installation

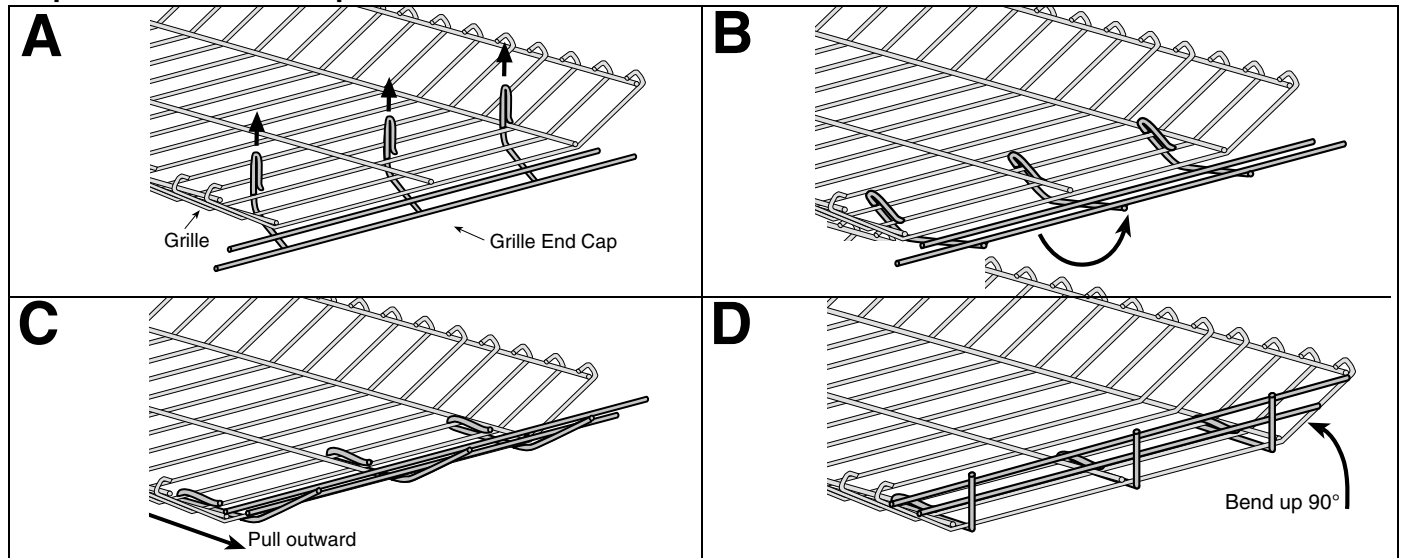

Step 8.8.3 Grille Installation

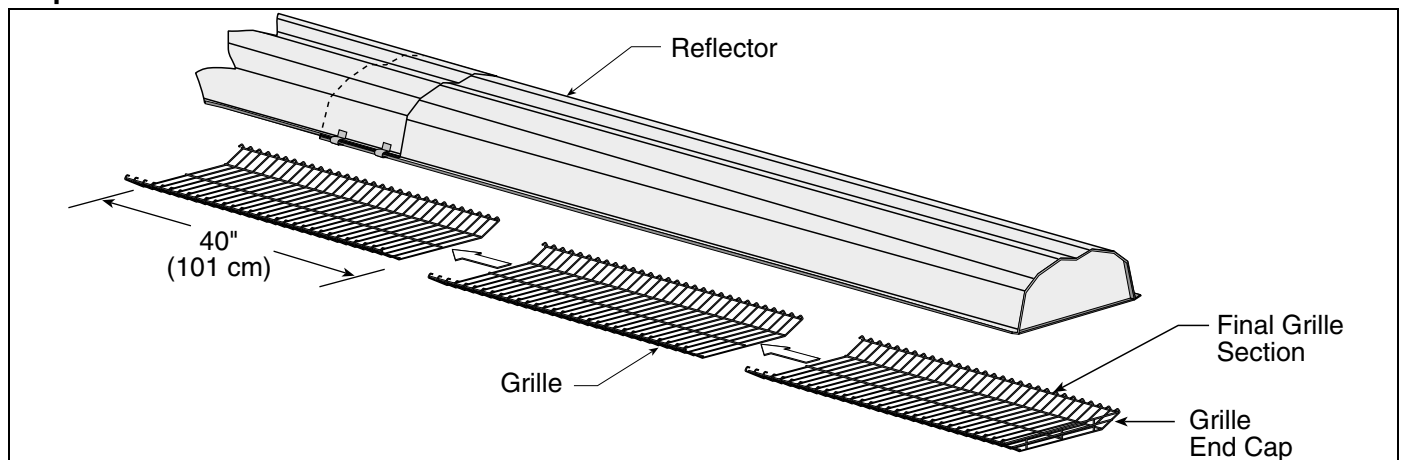

SECTION 9: PUMP INSTALLATION AND VENTING

⚠ WARNING



Carbon Monoxide Hazard

Heaters installed unvented must be interlocked with sufficient building exhaust.

Heaters must be installed according to the installation manual.

Failure to follow these instructions can result in death or injury.

⚠ WARNING



Cut/Pinch Hazard

Wear protective gear during installation, operation and service.

Edges are sharp.

Failure to follow these instructions can result in injury.

9.1 Pump Installation

For complete pump installation, including wiring and venting, please refer to the EP-100, EP-200 or EP-300 Series Installation, Operation and Service Manuals, latest edition.

FIGURE 24: Horizontal Venting Configuration (EP-100 and EP-300) (Category IV, Vent Gas Temperature Can Cause Excessive Condensation)

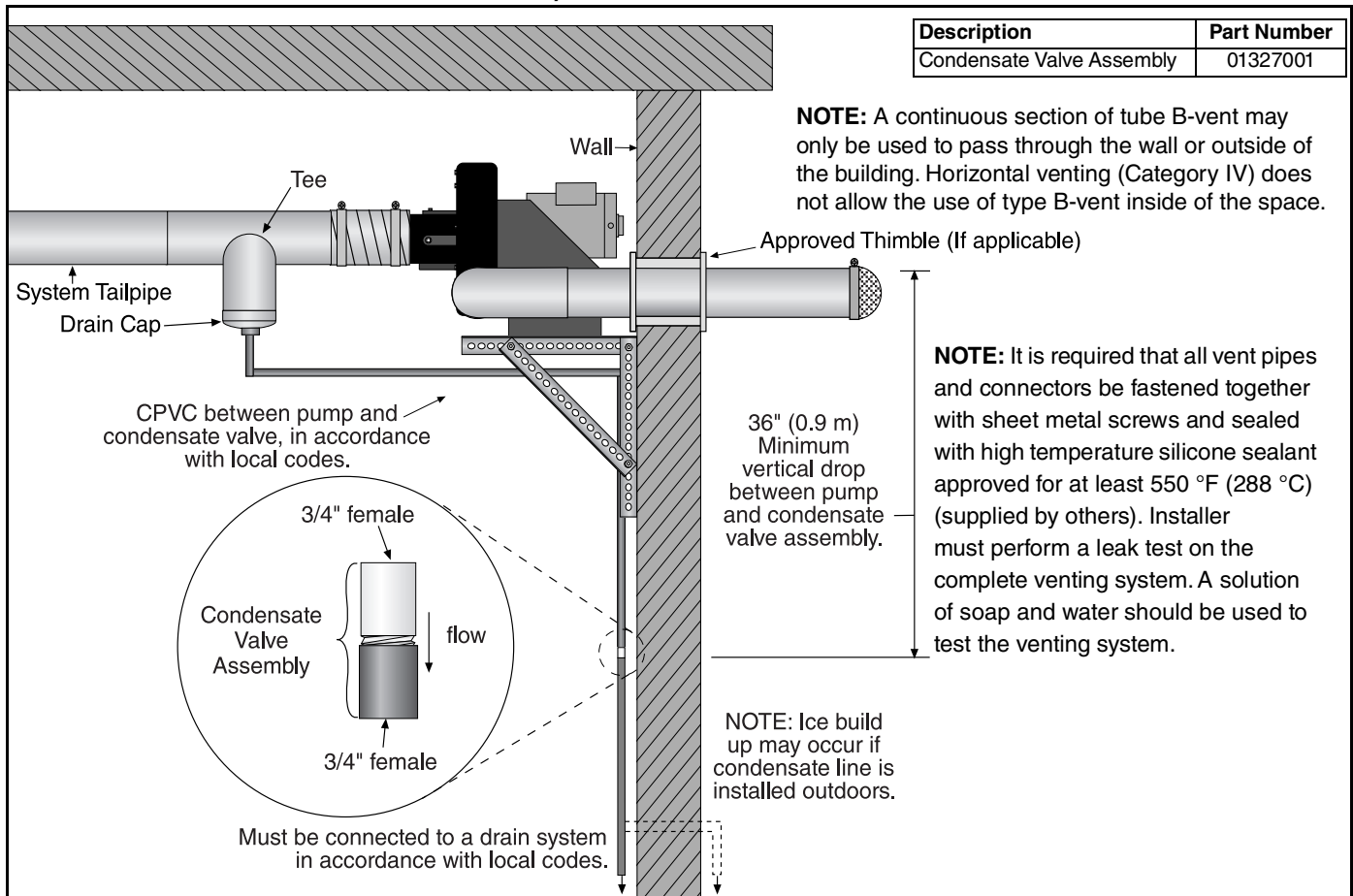
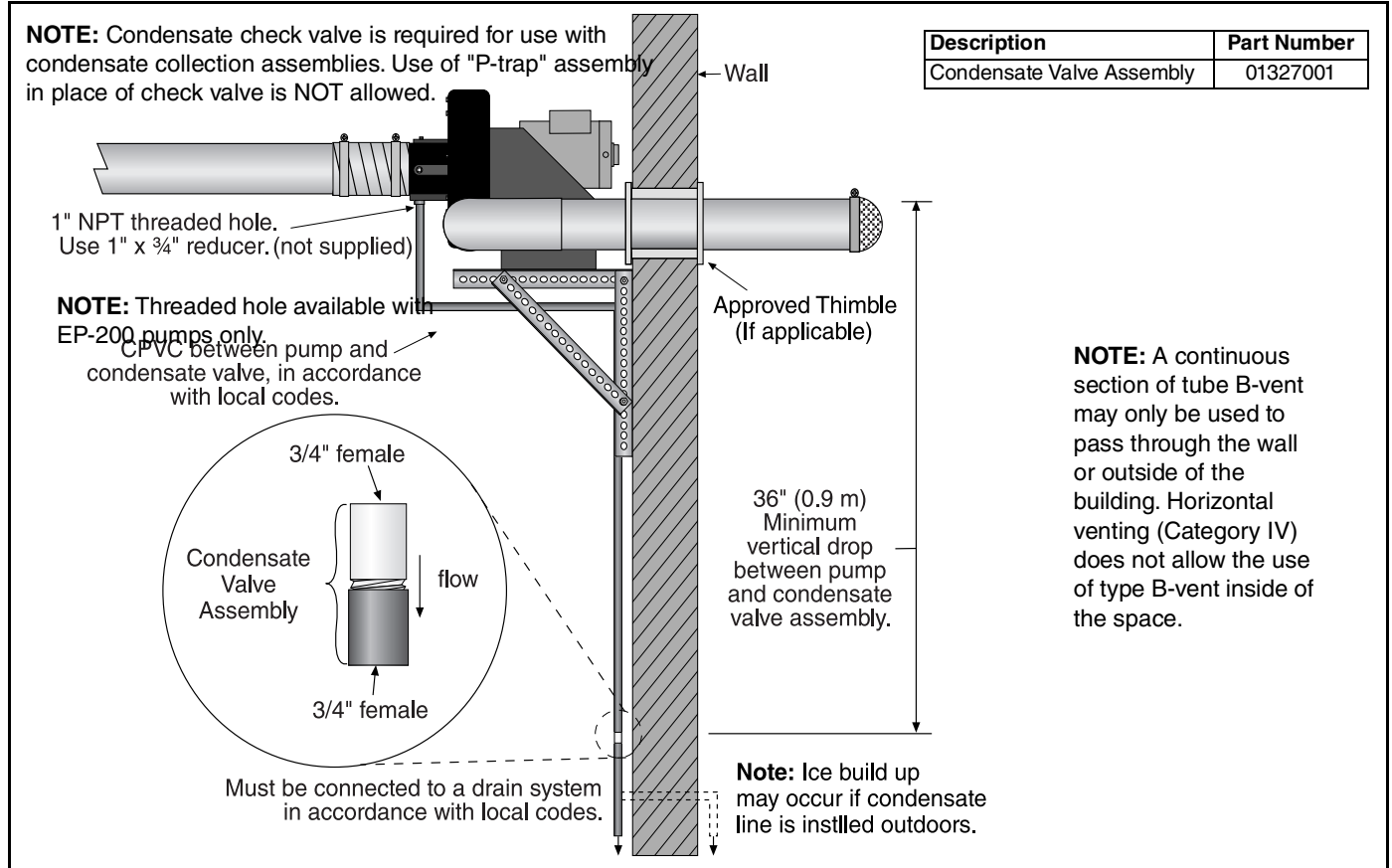

FIGURE 25: Horizontal Venting Configuration (EP-200)(Category IV, Vent Gas Temperature Can Cause Excessive Condensation)

NOTE: It is required that all vent pipes and connectors be fastened together with sheet metal screws and sealed with high temperature silicone sealant approved for at least 550 °F (288 °C) (supplied by others). Installer must perform a leak test on the complete venting system. A solution of soap and water should be used to test the venting system.

9.1.1 Condensate Neutralization Tube (optional)

If a condensate neutralization tube is specified to be used with the heating system, follow the steps below to choose the proper condensate neutralization tube. See Page 41, Figure 26.

Step 1: Condensate flow (gal/h) per 100,000 Btu/h installed

You will need to know the tailpipe length per flow unit and the total input (Btu/h) on the heating system. Please refer to the following chart to determine the condensate flow (gal/h) per 100,000 Btu/h installed:

Radiant Tube Length (average distance between burners)	Tailpipe Length per Flow Unit			
	Minimum	Recommended	1.7 ft/flow unit	Maximum
Minimum	N/A	0.1	0.3	0.6
Recommended	0.1	0.3	0.6	0.8
Maximum	0.3	0.6	0.8	0.8

Step 2: Total condensate

Determine the total condensate (gal/h) using the follow calculation:

$$\text{Total condensate (gal/h)} = \frac{\text{Total Input (Btu/h)}}{100,000 \text{ (Btu/h)}} \times \text{condensate flow (gal/h)}$$

Step 3: Choose the condensate neutralization tube

Choose the condensate neutralization tube which is closest to and higher than the calculated gal/h value.

Calculated gal/h	Description	Part Number
Less than 2	Condensate Neutralization Tube 200	01327002
Less than 10	Condensate Neutralization Tube 1500	01327006
Less than 20	Condensate Neutralization Tube 2000	01327005

Example:

CORAYVAC® system has a total input of 600,000 Btu/h. The radiant tube length and tailpipe are set-up according to the RECOMMENDED specifications.

Step 1: Condensate flow (gal/h) per 100,000 Btu/h installed

Select 0.3 from the Condensate flow chart.

Radiant Tube Length (average distance between burners)	Tailpipe Length per Flow Unit			
	Minimum	Recommended	1.7 ft/flow unit	Maximum
Minimum	N/A	0.1	0.3	0.6
Recommended	0.1	0.3	0.6	0.8
Maximum	0.3	0.6	0.8	0.8

Step 2: Total condensate

Multiply the total input Btu/h / 100,000 by the condensate flow (gal/h) per 100,000 (Btu/h)
 (600,000/100,000) x 0.3 = 1.8 (gal/h)

Step 3: Choose the condensate neutralization tube

Choose the condensate neutralization tube which is closest to and higher than the calculated gal/h value. For this example, the total condensate is 1.8 (gal/h), the condensate neutralization tube which is closest to and higher than the calculated gal/h value is P/N 01327002.

Calculated gal/h	Description	Part Number
Less than 2	Condensate Neutralization Tube 200	01327002
Less than 10	Condensate Neutralization Tube 1500	01327006
Less than 20	Condensate Neutralization Tube 2000	01327005

NOTE: Condensate neutralization tubes must be replaced yearly (every 2000 operating hours) or check condensate water pH level. If it is below pH 6, replace tube.

FIGURE 26: Condensate Neutralization Tube (Category IV, Vent Gas Temperature Can Cause Excessive Condensation)

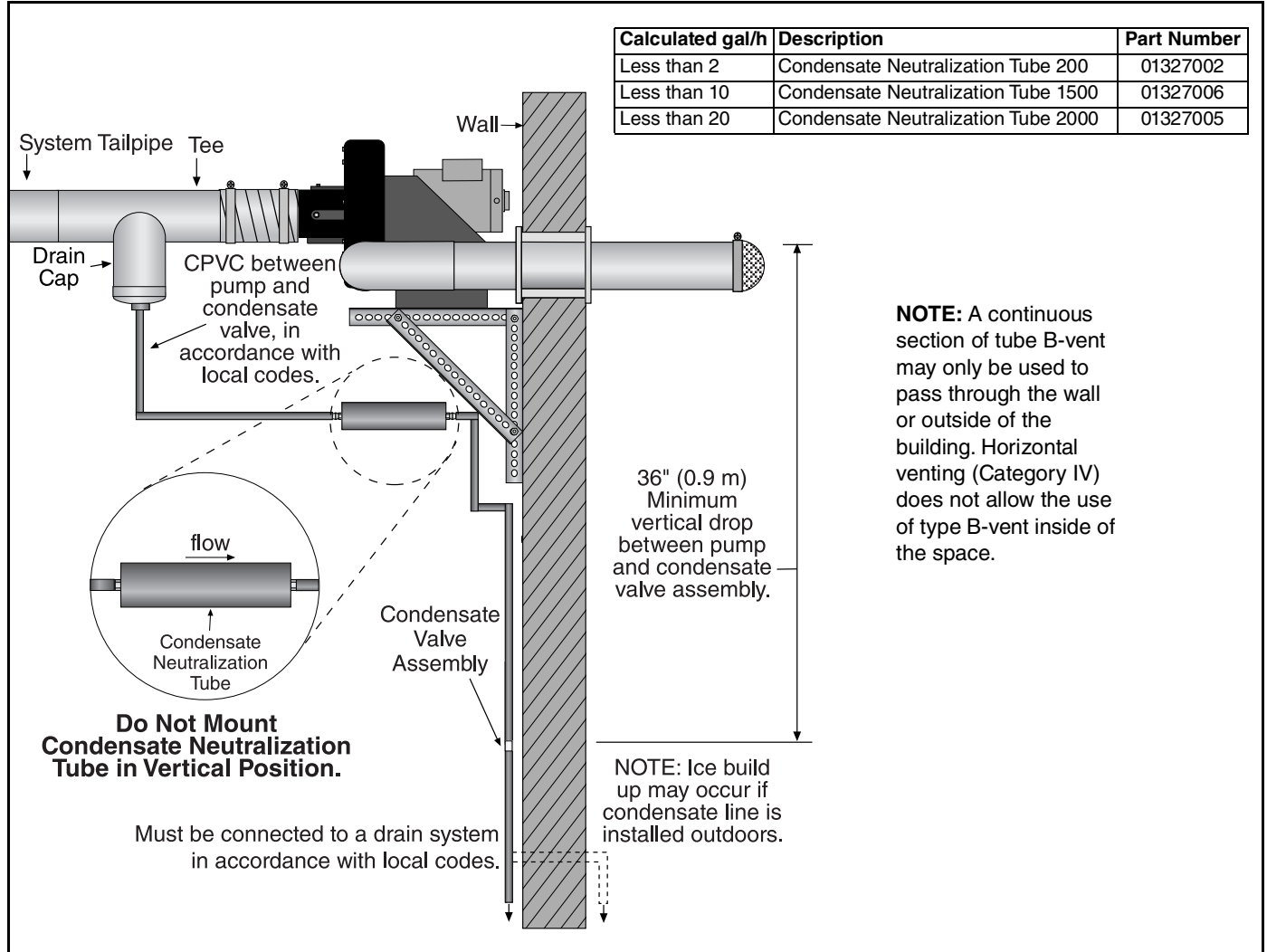

NOTE: It is required that all vent pipes and connectors be fastened together with sheet metal screws and sealed with high temperature silicone sealant approved for at least 550 °F (288 °C) (supplied by others). Installer must perform a leak test on the complete venting system. A solution of soap and water should be used to test the venting system.

9.2 General Venting Requirements Model EP-100, EP-200 and EP-300 Series Pumps

This heating system is considered a Category III or Category IV vented system.

This heating system must be vented in accordance with the rules contained in this manual and with the following national codes and any state, provincial or local codes which may apply:

United States: Refer to National Fuel Gas Code NFPA 54/ANSI Z223.1 - latest revision.

Canada: Refer to Natural Gas and Propane Installation Code CSA B149.1 - latest revision.

Any portion of vent pipe passing through a combustible wall must have an approved thimble to conform with the above listed codes.

Vent pipe must be sloped downward away from the pump $\frac{1}{4}$ " every 10' (3 m).

The bottom of the vent or air intake terminal shall not be located less than 1' (0.3 m) above grade level.

The vent shall not terminate less than 7' (2.1 m) above grade where located adjacent to public walkways.

Vent terminal must be installed at a height sufficient to prevent blockage by snow, and building materials protected from degradation by flue gases.

Secure all joints with #8 x $\frac{3}{8}$ sheet metal screws.

Seal all joints with high temperature silicone sealant.

Vent terminal must be beyond any combustible overhang.

9.2.1 United States Requirements

Vent must terminate at least 3' (0.9 m) above any forced air inlet located within 10' (3.1 m).

Vent must terminate at least 4' (1.2 m) below, 4' (1.2 m) horizontally from, or 1' (0.3 m) above any door, operable window, or gravity air inlet into any building.

9.2.2 Canadian Requirements

The vent shall not terminate within 6' (1.8 m) of a mechanical air supply inlet to any building.

The vent shall not terminate within 3' (0.9 m) of a window or door that can be opened in any building, any non-mechanical air supply inlet to any building, or of the combustion air inlet of any other appliance.

Step 9.2.3 Vent Category Definitions

Radiant tube heaters are divided into four categories based on the static pressure produced in the vent and the percentage flue loss.

Category I – a radiant tube heater that operates with a non-positive vent static pressure and with a vent gas temperature that avoids excessive condensate production in the vent

Category II – a radiant tube heater that operates with a non-positive vent static pressure and with a vent gas temperature that can cause excessive condensate production in the vent

Category III - a radiant tube heater/heating system that operates with a positive vent static pressure and with a vent gas temperature that avoids excessive condensate production in the vent

Category IV - a radiant tube heater/heating system that operates with a positive vent static pressure and with a vent gas temperature that can cause excessive condensate production in the vent

This heating system is considered a Category III or Category IV vented appliance.

CORAYVAC® heating system has a wide range of design flexibility which affects how system venting may be configured. Horizontal or vertical venting configurations do not determine venting category. CORAYVAC® Design Manual (P/N 127500NA) and Section 9.3 must be referenced to determine if system is condensing (Category IV) or non-condensing (Category III). All condensing systems will require proper collection and disposal of condensate formed by the heating system. This manual will illustrate venting configurations and installation instructions.

9.2.4 Vertical Venting

See Page 45, Figure 27 for recommended vertical venting options.

Approved venting material for vertical venting (Category III or Category IV) must be single-wall corrosion resistant with a thickness of no less than 26 gauge. It is required that all vent pipes and connectors be fastened together with sheet metal screws and sealed with high temperature silicone sealant approved for at least 550 °F (288 °C) (supplied by others). The installer must perform a leak test on the complete venting system. A solution of soap and water should be used to test the venting system. A continuous section of type B-vent may only be used to pass through the roof or outside of the building. Vertical venting (Category III or Category IV) does not allow the use of type B-vent inside of the space.

Category IV venting requires condensate collection method to properly collect and dispose of condensate formed by the heating system. This manual will illustrate examples of proper condensation collection methods.

9.2.5 Horizontal Venting

See Page 46, Figure 28 through Page 48, Figure 10 for recommended horizontal venting options.

Approved venting material for horizontal venting (Category III or Category IV) must be single-wall corrosion resistant with a thickness of no less than 26 gauge. It is required that all vent pipes and connectors be fastened together with sheet metal screws and sealed with high temperature silicone sealant approved for at least 550 °F (288 °C) (supplied by others). The installer must perform a leak test on the complete venting system. A solution of soap and water should be used to test the venting system. A continuous section of type B-vent may only be used to pass through the side wall or outside of the building. Horizontal venting (Category III or Category IV) does not allow the use of type B-vent inside of the space.

Category IV venting requires condensate collection method to properly collect and dispose of condensate formed by the heating system. This manual will illustrate examples of proper condensation collection methods.

NOTE: Category I or Category II is not a possible configuration with this heating system.

9.2.6 Length Requirements

See EP-100, EP-200 or EP-300 Pump Series Installation, Operation and Service Manuals for complete venting options.

Vent lengths are allowed as follows:

Vent Length	EP-300 Vent Size	EP-200 Vent Size	EP-100 Vent Size
Up to 10' (3 m)	6" (15 cm) - 1 elbow	4" (10 cm) - 1 elbow	4" (10 cm) - 3 elbows
Up to 25' (8 m)	7" (18 cm) - 3 elbow	5" (12.7 cm) - 3 elbows	4" (10 cm) - 3 elbows
Up to 50' (15 m)	8" (20 cm) - 3 elbow	6" (15 cm) - 3 elbows	5" (12.7 cm) - 3 elbows

NOTE: It is required that all vent pipes and connectors be fastened together with sheet metal screws and sealed with high temperature silicone sealant approved for at least 550 °F (288 °C) (supplied by others). Installer must perform a leak test on the complete venting system. A solution of soap and water should be used to test the venting system. Insulation and additional sealing measures may be required.

Optional heat exchanger lengths are considered as vent length for length determination.

Subtract 15' (4.6 m) of maximum allowed vent or outside air duct length per vent elbow if more than three are used.

9.2.7 Vent Material Recommendations

Vent recommendations:

1. Porcelain coated tubing 4" (10 cm) O.D. (P/N 9141030D)
2. Heat treated aluminized tubing 4" (10 cm) O.D. (P/N 91409408)
Heat treated aluminized tubing 6" (15 cm) O.D. (P/N E0009105)
3. Single wall pipe (Type-C) that is corrosion resistant galvanized steel (or equivalent) - minimum 26 ga. (Supplied by others)
4. Double wall vent (Type-B). For use as a continuous section passing through the outside wall, roof or outside of the building only.
5. Schedule 40 ASTM A53 (Latest Edition) grad B ERW black steel pipe.

NOTE: 4" (10 cm) O.D. Porcelain coated tubing (P/N 9141030D), 4" (10 cm) O.D. Heat treated aluminized tubing (P/N 91409408), and 6" (15 cm) O.D. Heat treated aluminized tubing (P/N E0009105) are equivalent to single wall corrosion resistant flue pipe.

9.3 Tube Length vs Efficiency

Vent gas temperatures determine if heating system falls under Category III or Category IV. Graph below is used to calculate thermal efficiency which will influence vent gas temperatures and determine vent category defined below as "Non-Condensing (Category III)" and "Condensing (Category IV)".

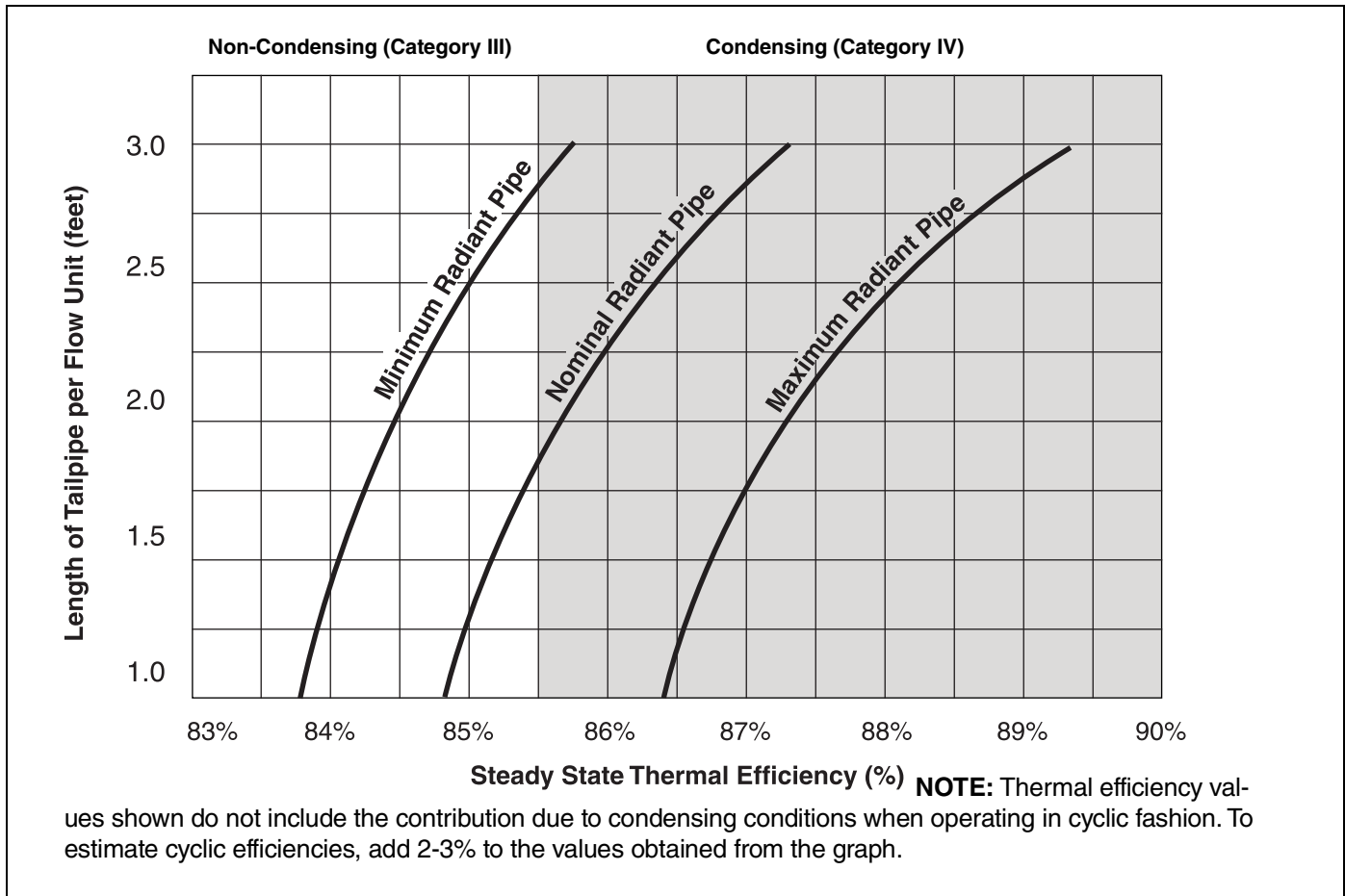
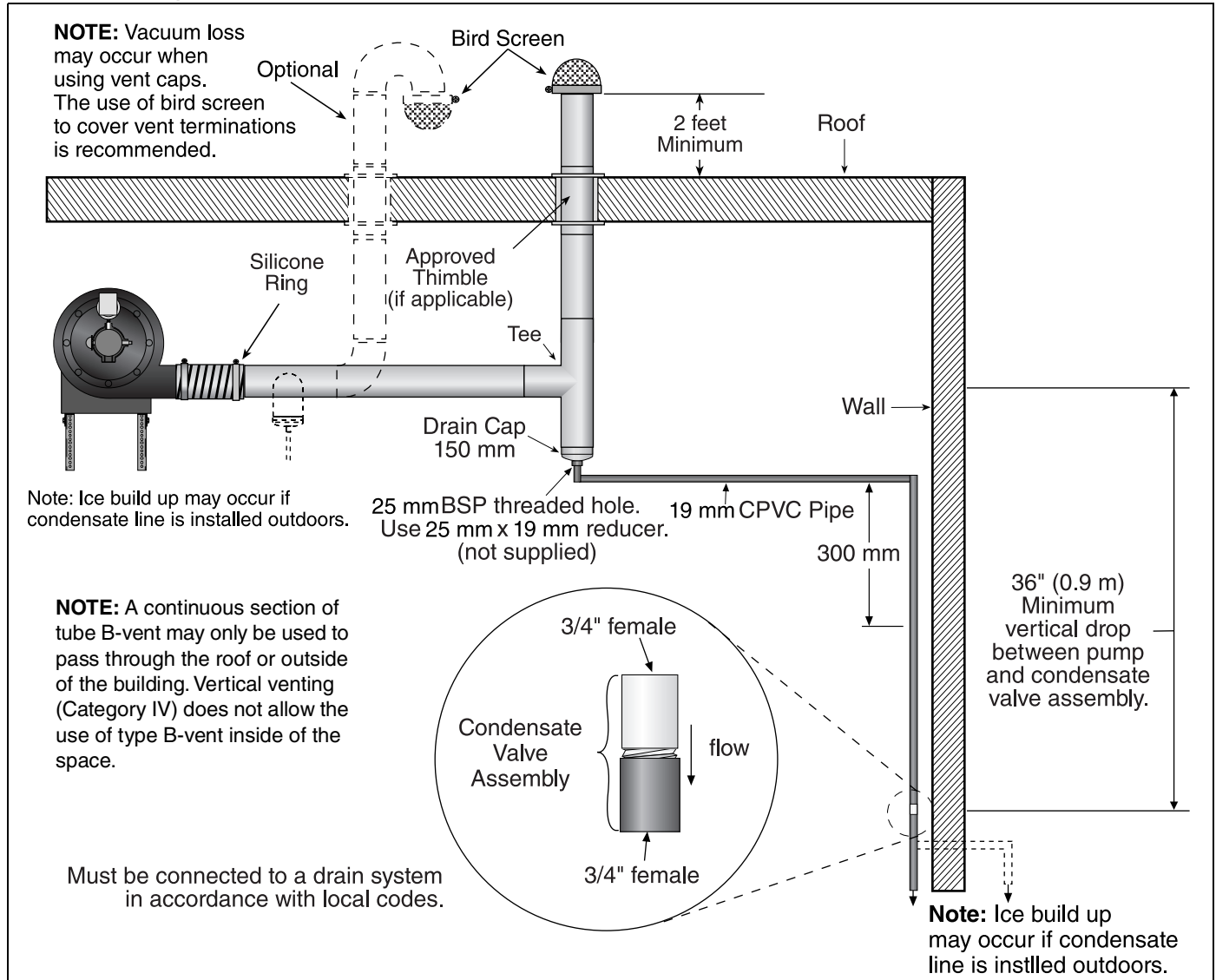

FIGURE 27: Vertical Venting Configuration (Category IV, Vent Gas Temperature Can Cause Excessive Condensation)

Part Number	Description	Part Number	Description
01330203	Tee, 4" (10 cm) Aluminized	91412801	Flexible Boot, 4.5" (11 cm)
01330204	Tee, 6" (15 cm) Aluminized	91412802	Flexible Boot, 6" (15 cm)
01335801	Elbow, 4" (10 cm) Aluminized 90°	91901300	Boot Clamp, 4" (10 cm)
02718851	Drain Cap, 4" (10 cm)	91913703	Boot Clamp, 6" (15 cm)
02718852	Drain Cap Assembly, 6" (15 cm)	T0100320	Elbow, 6" (15 cm) Aluminized 90°
01327002	Condensate Neutralization Tube 200	01365400	Bird Screen 4" (10 cm)
01327006	Condensate Neutralization Tube 1500	01397400	Bird Screen 6" (15 cm)
01327005	Condensate Neutralization Tube 2000	01335901	Aluminized U-Tube 4" (10 cm)
90502300	Vent Cap, 4" (10 cm) Metalbestos	91906900	Silicone Ring
90502302	Vent Cap, 6" (15 cm) Metalbestos	01327001	Condensate Valve Assembly

NOTE: It is required that all vent pipes and connectors be fastened together with sheet metal screws and sealed with high temperature silicone sealant approved for at least 550 °F (288 °C) (supplied by others).

Installer must perform a leak test on the complete venting system. A solution of soap and water should be used to test the venting system.

FIGURE 28: EP-100 and EP-200 Vertical Venting Configurations (Category III, Vent Gas Temperature Avoids Excessive Condensation)

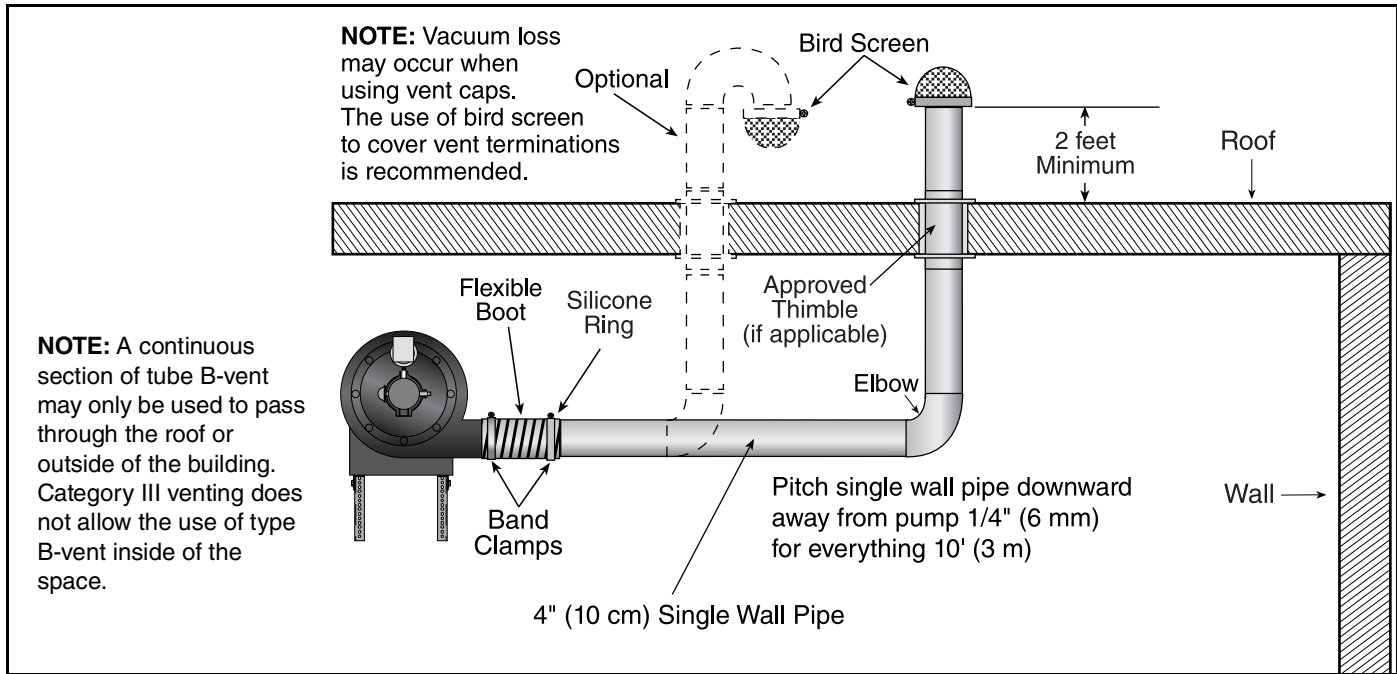

NOTE: It is required that all vent pipes and connectors be fastened together with sheet metal screws and sealed with high temperature silicone sealant approved for at least 550 °F (288 °C) (supplied by others). Installer must perform a leak test on the complete venting system. A solution of soap and water should be used to test the venting system.

FIGURE 29: EP-100 and EP-200 Horizontal Venting Configurations (Category III, Vent Gas Temperature Avoids Excessive Condensation)

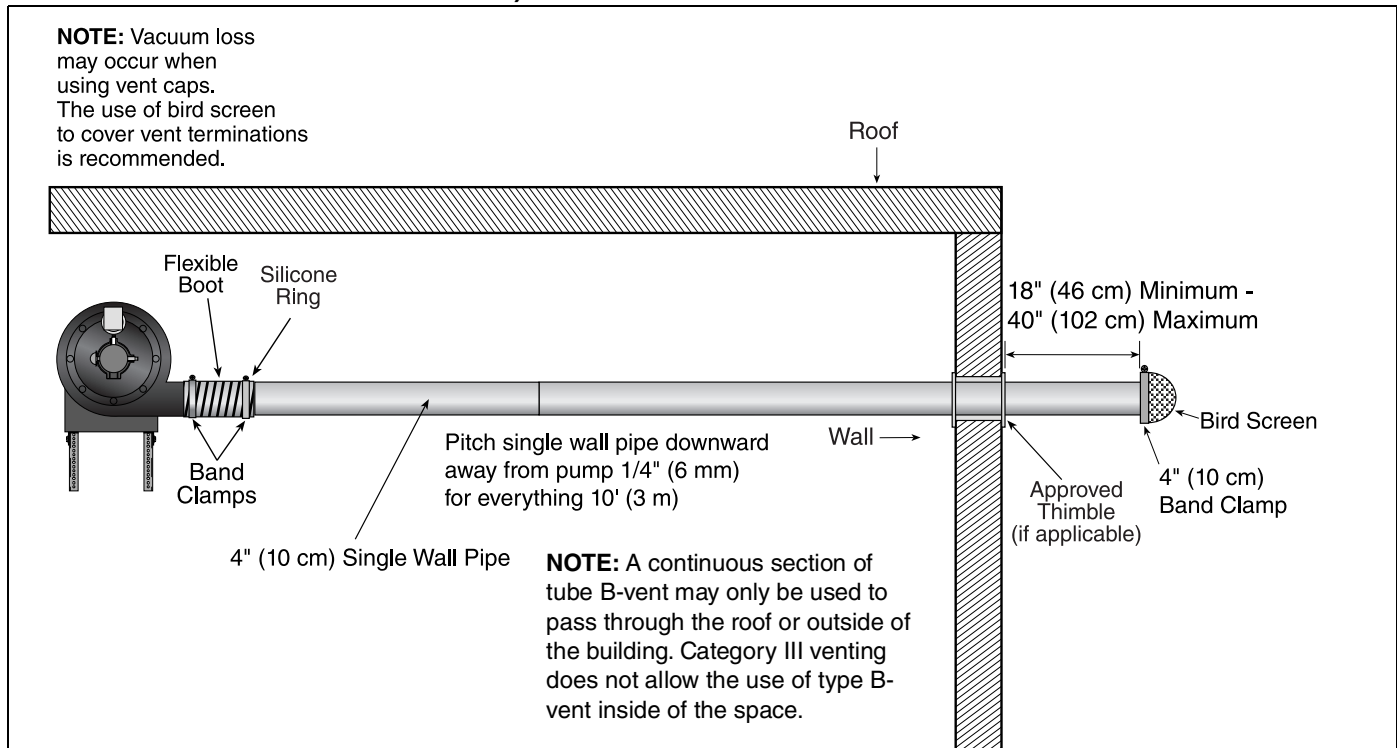
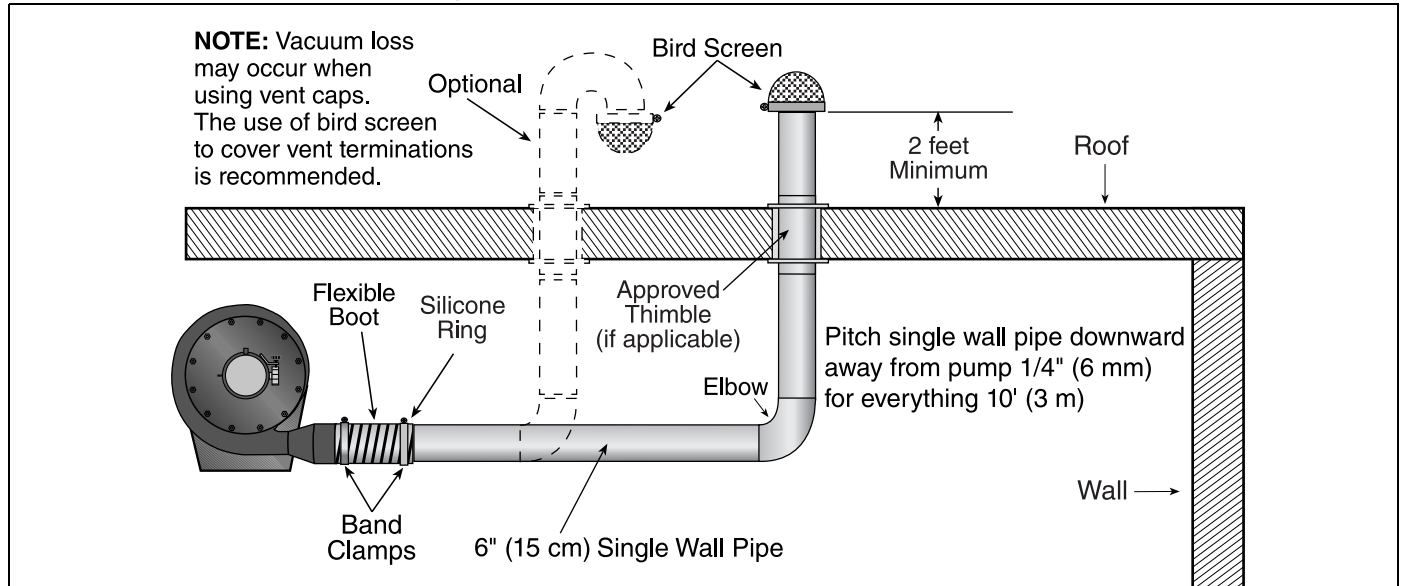

FIGURE 30: EP-300 Series Vertical Venting Configurations (Category III, Vent Gas Temperature Avoids Excessive Condensation)



Part Number	Description	Part Number	Description
01330203	Tee, 4" (10 cm) Aluminized	01327005	Condensate Neutralization Tube 2000
01331900	Damper Coupling, 4" (10 cm)	91409403	Tube, Aluminized 4" (10 cm) dia. 10' (3 m)
01335801	Elbow, 4" (10 cm) Aluminized 90°	91409420	Tube, Aluminized 6" (15 cm) dia. 10' (3 m)
01365400	Bird Screen, 4" (10 cm)	91412801	Flexible Boot, 4.5" (11 cm)
01397400	Bird Screen, 6" (15 cm)	91418200	Tube Adapter, 6" (15.2 cm) dia. x 4" (10 cm) dia.
02718851	4" Drain Cap	91901300	Boot Clamp, 4" (10 cm)
01327002	Condensate Neutralization Tube 200	91906900	Silicone Ring
01327006	Condensate Neutralization Tube 1500	91412802	Flexible Boot, 6" (13cm)

NOTE: It is required that all vent pipes and connectors be fastened together with sheet metal screws and sealed with high temperature silicone sealant approved for at least 550 °F (288 °C) (supplied by others). Installer must perform a leak test on the complete venting system. A solution of soap and water should be used to test the venting system.

FIGURE 31: EP-300 Series Horizontal Venting Configurations (Category III, Vent Gas Temperature Avoids Excessive Condensation)

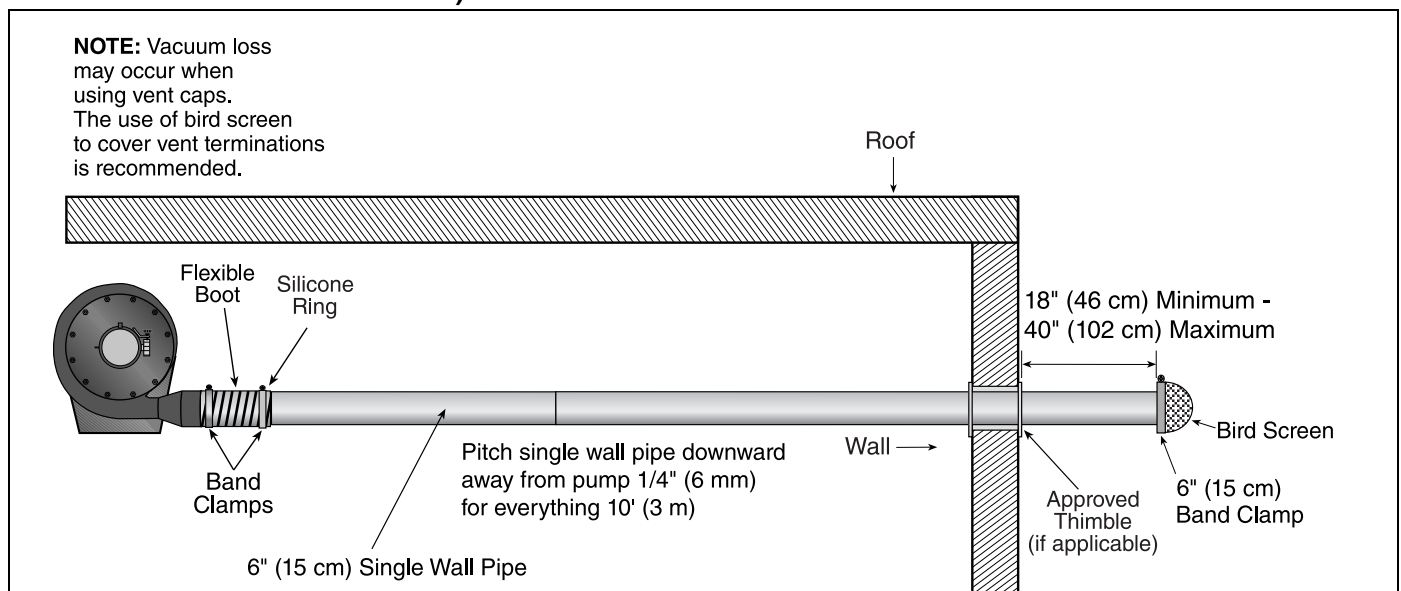

SECTION 10: OUTSIDE AIR SUPPLY**⚠ CAUTION****Product Damage Hazard**

Do not use heater in area containing corrosive chemicals.

Refer to appropriate Material Safety Data Sheets (MSDS).

Failure to follow these instructions can result in product damage.

The CRV-Series system is approved for use with an outside air system. Halogenated hydrocarbons or other corrosive chemicals in the air can be drawn into the equipment and seriously damage the system components. Avoid the use of such chemical compounds near the air inlet to the heaters.

IMPORTANT: If the building has a slight negative pressure or corrosive contaminants are present in the air, an outside combustion air supply to the heater is required.

All joints and seams in the air supply system must be airtight. Attach the filter housing to the burner assembly using the wing nut provided.

Note: Outside air terminal must not be more than 1' (31 cm) above the vent termination while maintaining a minimum distance of 3' (93 cm) for both vertical and horizontal venting.

10.1 Pressurized

See Page 51, Figure 36 for a typical layout of a pressurized air supply system.

For pressurized outside air supplies, the outside air blower motor has a pressure switch that must be used. Wire this switch in series with the pump pressure switch. When using an outside air blower with a CORAYVAC® Heating Control or CORAYVAC® Modulating Heating Control or relay transformer, a separate load relay package is required. Wire the control for the relay in parallel with the pump. The outside air blower must have a separate 20 A, 120 V power supply. See Page 49, Figure 33 for outside air blower internal wiring requirements. The outside air blower has an adjustable internal damper that should be wide open. On smaller systems (about 3 burners) this damper might need to be closed up to half way if

the pressure switch does not make.

10.2 Non-Pressurized

For a non-pressurized outside air supply, a 4" (O.D.) single wall pipe duct may be attached to the burner and end vent. For length and duct sizing requirements, see duct design rules in Figure 32. To prevent condensation, insulate the outside air duct.

FIGURE 32: Duct Sizing**Outside Air System Design Requirements:****Blower Performance (90707501K):****112 Flow Units**

One outside air blower is required per each EP-100 or EP-200 series pump and two outside air blowers may be required for each EP-300 series pump. Outside air blowers cannot be shared between two separate CRV-Series systems.

Duct Design Rules:

- System should be designed so that the blower is positioned closest to the highest flow requirements (end vents).
- When a duct is carrying more than 40 flow units, it must be at least 6" (15 cm) diameter.

Pressurized Systems

- 6" (15 cm) diameter duct must not exceed 120' (36 m) total per system.
- 4" (10 cm) diameter duct must not exceed 120' (36 m) per radiant branch.

Non Pressurized

- 6" (15 cm) diameter duct must not exceed 90' (27 m) maximum 100 flow units
- 4" (10 cm) diameter duct must not exceed 90' (27 m)
- Elbows are equivalent to 10' (3 m) of duct length.

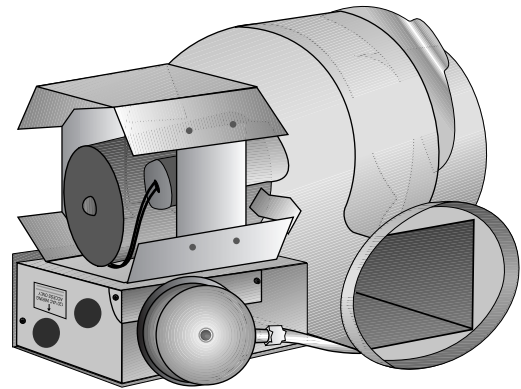
**10.3 Outside Air Blower Internal Wiring****FIGURE 33: Outside Air Blower Internal Wiring Diagram**

The outside air blower is shipped with the blower manufacturer's standard internal wiring. For use with ROBERTS GORDON® heaters, the outside air blower must be rewired with existing wires by the electrical contractor. See diagram.

NOTE: The internal 24 V relay provided will not be used and can be discarded.

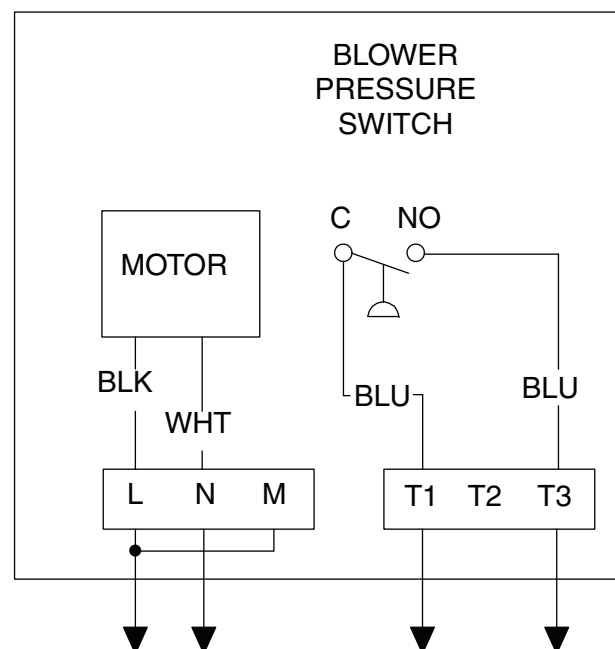

FIGURE 34: Filter Housing Assembly

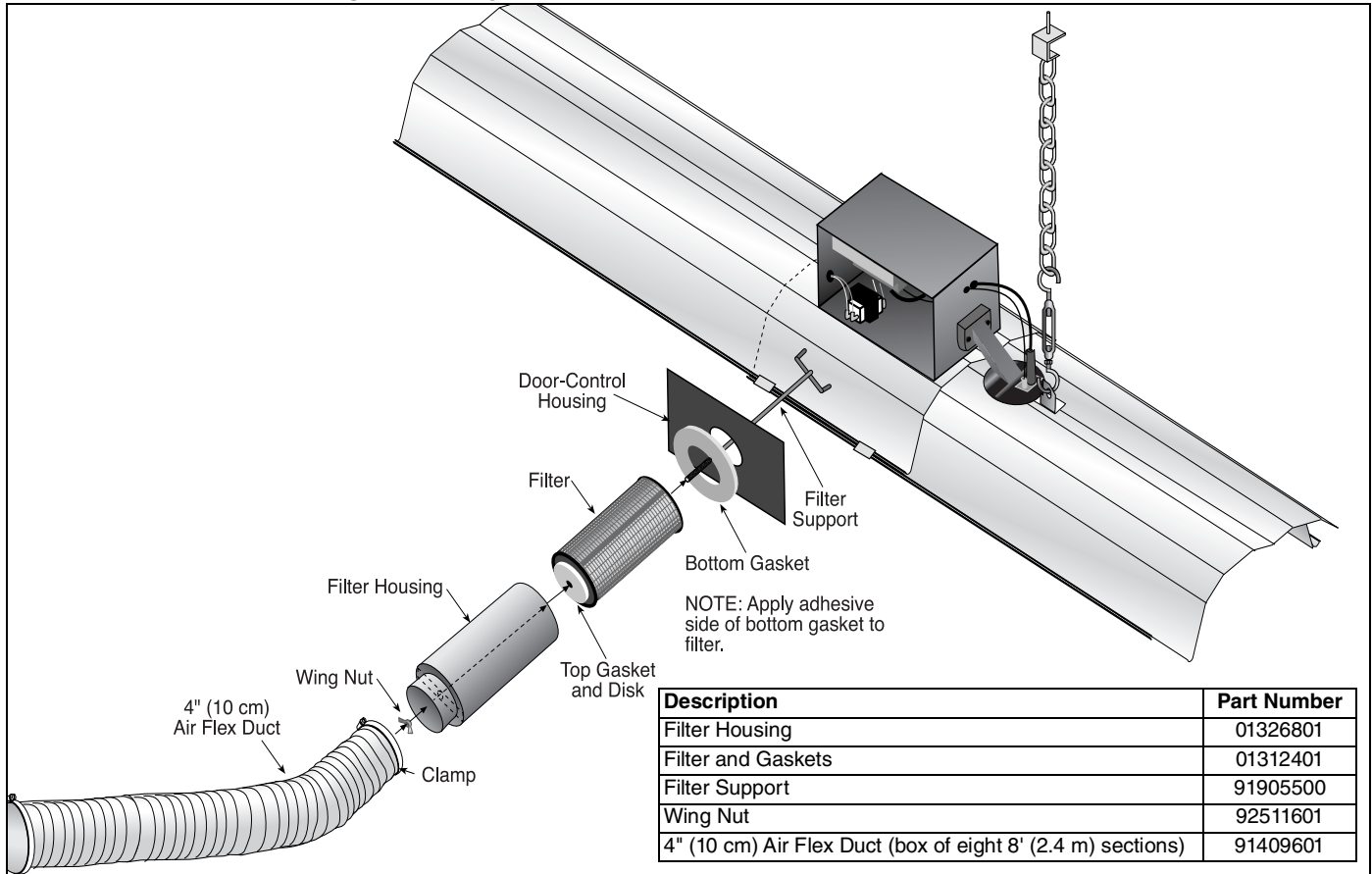

FIGURE 35: Air Supply Blower Support

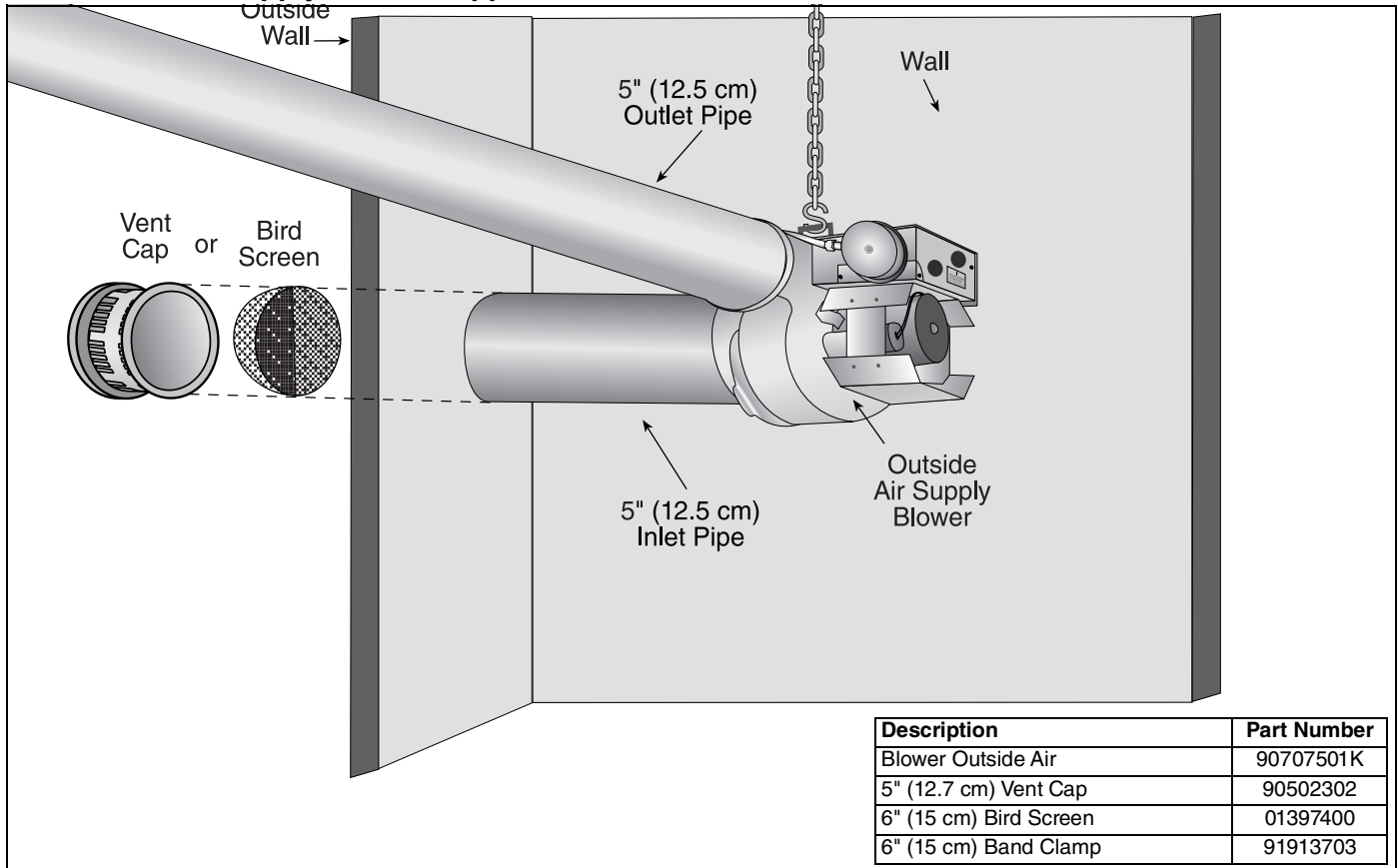

FIGURE 36: Pressurized Outside Air Supply

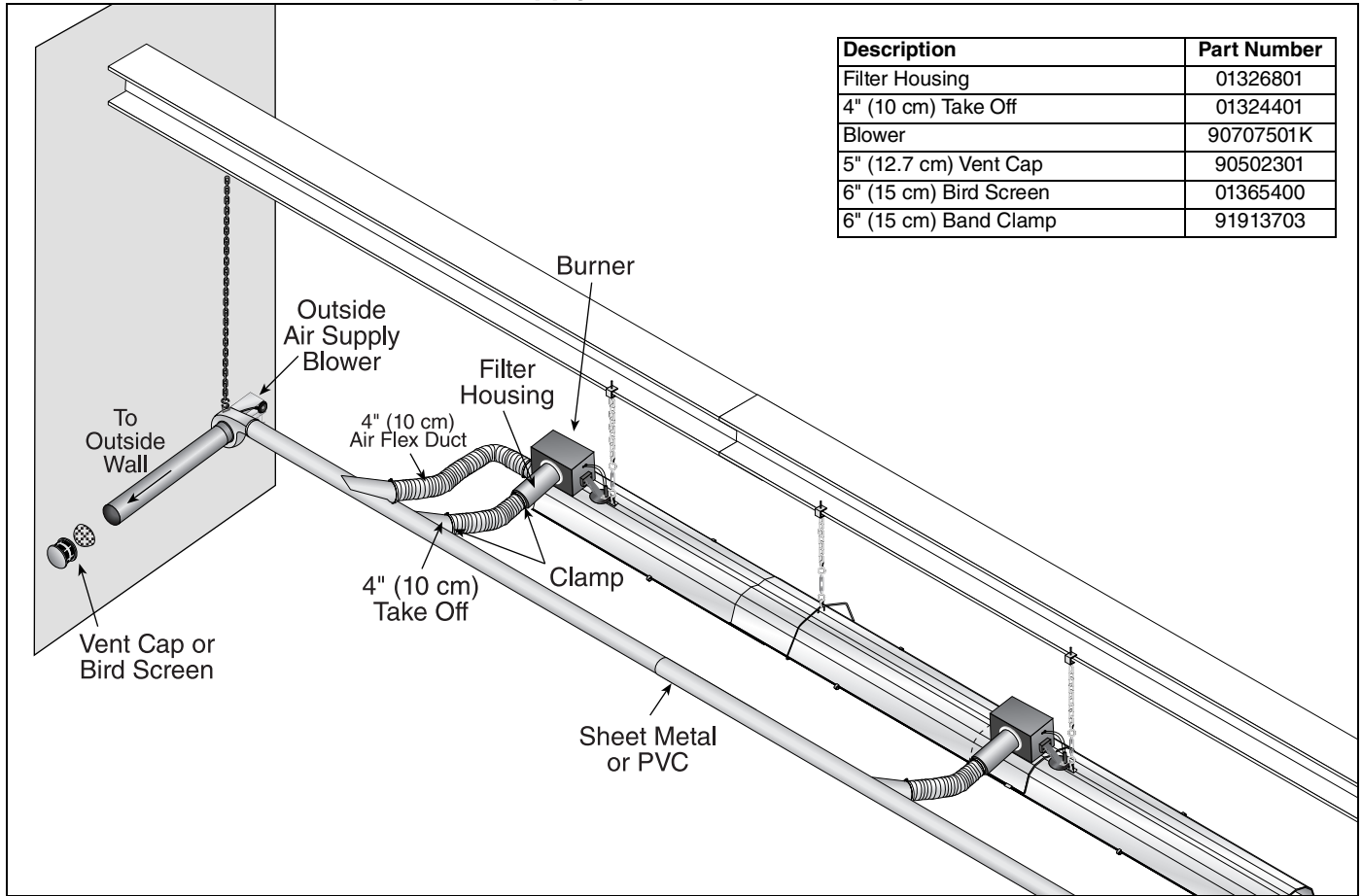
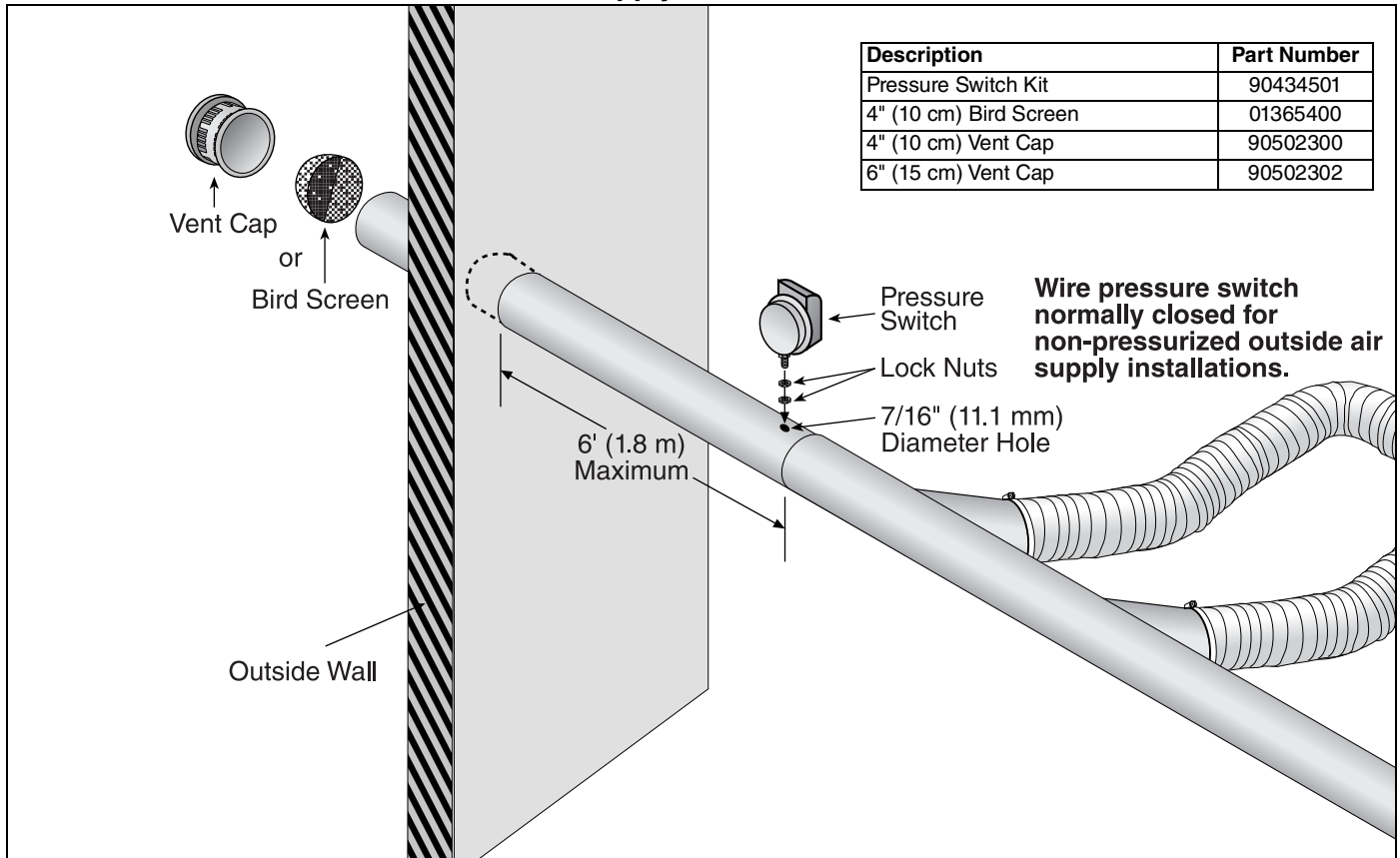



FIGURE 37: Non-Pressurized Outside Air Supply



SECTION 11: GAS PIPING

⚠ WARNING

Fire Hazard
Tighten gas hose fittings to connect gas supply according to Figure 28.
Gas hose can crack when twisted.
Gas hose moves during normal operation.
Use only 36" (91 cm) long connector of 1/2" or 3/4" nominal ID.
Connector supplied with heater for U.S. models (not with Canadian models).
Failure to follow these instructions can result in death, injury or property damage.

⚠ WARNING

Explosion Hazard
Leak test all components of gas piping before operation.
Gas can leak if piping is not installed properly.
Do not high pressure test gas piping with heater connected.
Failure to follow these instructions can result in death, injury or property damage.

Install the gas hose as shown on Page 53, Figure 38. The gas hose accommodates expansion of the heating system and allows for easy installation and service of the burner. Before connecting the burners to the supply system, verify that all high pressure testing of the gas piping has been completed.

There is an expansion of the tube with each firing cycle. This will cause the burner to move with respect to the gas hose. This can cause a gas leak resulting in an unsafe condition if the gas connection is not made in strict accordance with *Figure 38*.

Meter and service must be large enough to handle all the burners being installed plus any other connected load. The gas hose which feeds the system must be large enough to supply the required gas with a maximum pressure drop of 1/2" wc. When gas piping is not included in the layout drawing, the local gas supplier will usually help in planning the gas piping.

Gas lines must meet applicable codes:

United States: The Flexible Stainless Steel Gas Hose (US models) supplied with the heater is certified per the Standard for Connectors for Gas Appliances, ANSI Z21.24/CSA 6.10 - latest revision.

Canada: The Rubber Type 1 Gas Hose (Canadian models) optional with the heater is certified as being in compliance with the Standard for Elastomeric Composite Hose and Hose Couplings for Conducting Propane and Natural Gas, CAN/CGA 8.1 - Latest revision.

- **Check the pipe and tubing ends for leaks before placing heating equipment into service. When checking for gas leaks, use a soap and water solution; never use an open flame.**

FIGURE 38: Gas Connection with Flexible Gas Hose

CORRECT POSITIONS

Shut-Off Valve (included with gas hose) must be parallel to burner gas inlet. The 3" (8 cm) displacement shown is for the cold condition. This displacement may reduce when the system is fired.

High Gas Pressure Regulator to be installed upstream of flexible gas hose if inlet pressure exceeds maximum allowance. See Page 83, Section 20.

CAUTION

Product Damage Hazard

Hold gas nipple securely with pipe wrench when attaching gas hose.

Failure to follow these instructions can result in product damage.

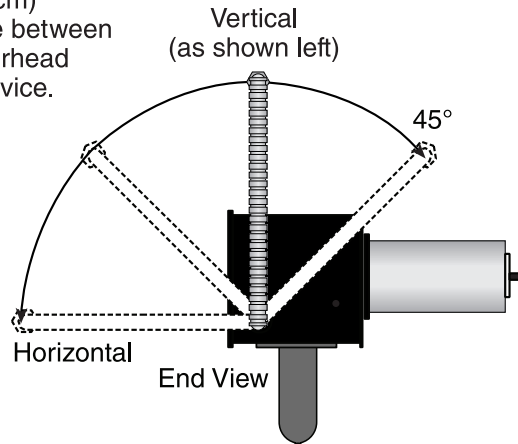
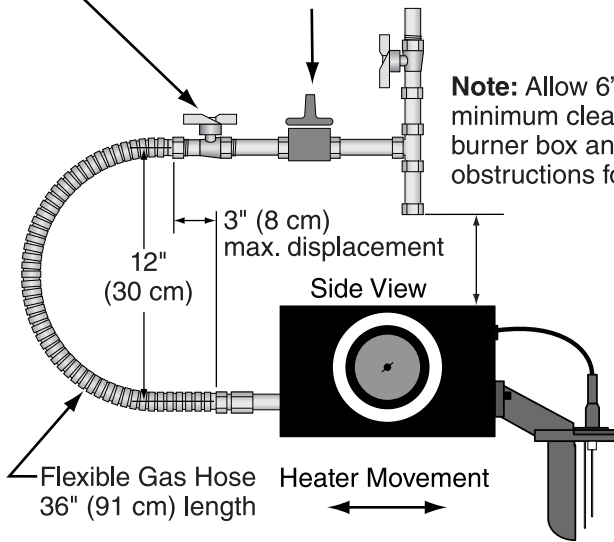

Description	Part Number
High Pressure Regulator - 2 psi	90207600
High Pressure Regulator - 5 psi	90207601

INCORRECT POSITIONS (WRONG INSTALLATION)

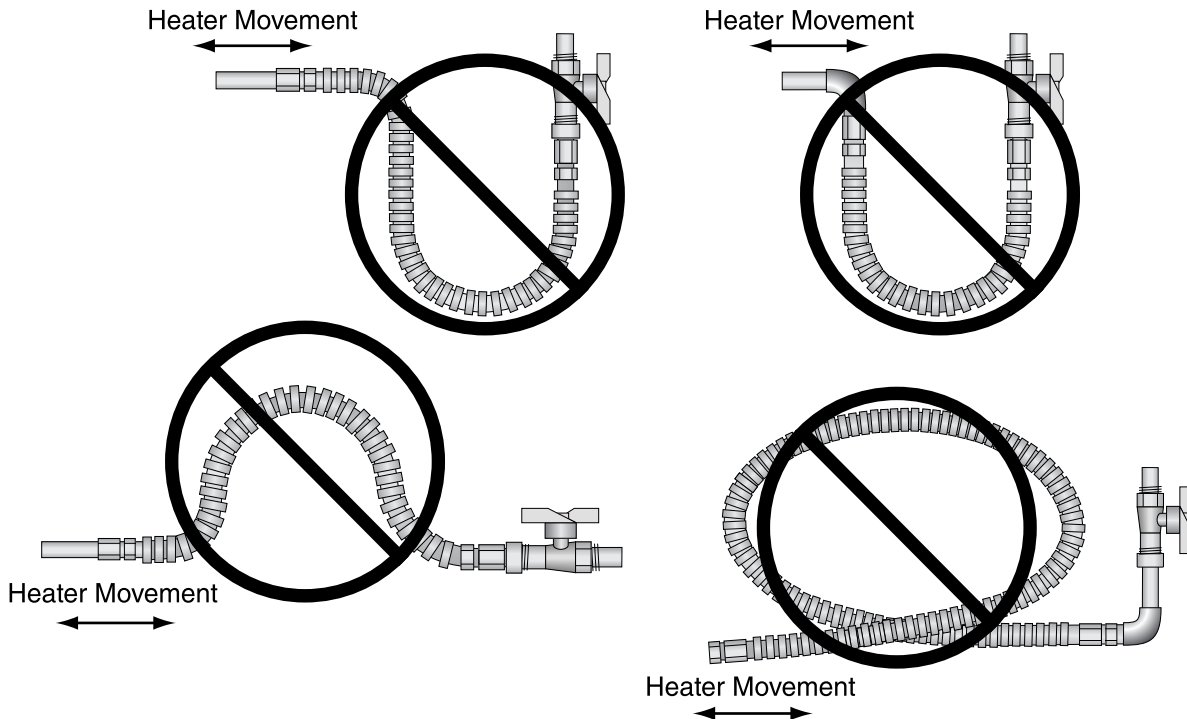

Description	Part Number
1/2" Flexible Stainless Steel Gas Hose (US Models)	91412200
1/2" Rubber (Type 1) Gas Hose (Canadian Models)	91412206

SECTION 12: CONTROL METHODS

⚠ DANGER

Electrical Shock Hazard
<p>Disconnect electric before service or maintenance.</p> <p>More than one disconnect switch may be required to disconnect electric to the unit.</p> <p>Control must be properly grounded to an electrical source.</p> <p>Failure to follow these instructions can result in death or electrical shock.</p>

⚠ WARNING

Explosion Hazard
<p>Turn off gas supply to heater before service.</p> <p>Failure to follow these instructions can result in death, injury or property damage.</p>

There are several methods of controlling CRV-Series systems. The options are as follows:

12.1 CORAYVAC® Heating Control

The CORAYVAC® Heating Control is an electronic control panel designed to control CRV-Series heating systems. The CORAYVAC® Heating Control wiring is shown on Page 59, Figure 42 through Page 61, Figure 45 and in the CORAYVAC® Heating Control Installation Manual (P/N 10091601NA).

The CORAYVAC® Heating Control can be used to control an EP-100 or EP-201 pump from the control panel. Other pumps such as the EP-301 and 3 Ø models may be controlled in conjunction with a relay or motor starter. The CORAYVAC® Heating Control can control up to four zones of burners and up to two vacuum pumps.

The electrical circuit is a 120 Vac (20 A) supply. The output for the thermostat is 24 Vac. A CORAYVAC® Heating Control operated system has two minutes post purge pump operation to

completely exhaust products of combustion from the system. A CORAYVAC® Heating Control provides indication of power to the pump and zones and indicates the status of the pressure switch with lights. The CORAYVAC® Heating Control is ETL listed in accordance with UL873 – Standard for Temperature Indicating and Regulating Equipment.

12.2 CORAYVAC® Modulating Heating Control (CRV-B 6/8/9/10/12/12A Only)

The CORAYVAC® Modulating Heating Control is a micro-processor based control package designed for modulating control of CRV-Series heaters based on outdoor temperatures. The controls offer full modulation between 60% and 100% of system maximum rated input.

This controller is capable of giving control outputs to two pumps and four heating zones. The controller also features inputs which are used for indoor and outdoor signal condition monitoring.

System status and settings are viewed and altered from a touchscreen. For complete installation details, please refer to the CORAYVAC® Modulating Heating Control Installation, Operation and Service Manual (P/N 1006101NA), latest revision.

Special design requirements apply for CRV-Series systems using the CORAYVAC® Modulating Heating Control Controller.

Buildings today demand all sorts of control options based on the user’s preference. CORAYVAC® Modulating Heating Control controls offer a host of communication options for integration with controls’ networks to best serve individual needs:

CORAYVAC® Modulating Heating Control BMS Link:

Interface CORAYVAC® Modulating Heating Control with other building management control platforms using BACnet® or MS/TP protocol which communicates via our CORAYVAC® Modulating Heating Control BMS Link option.

Offsite Access: Contact your ROBERTS GORDON® distributor to gain access to WebCTRL®. WebCTRL® is an internet based program that allows remote connectivity to your CORAYVAC® Modulating Heating Control through a PC, or a smart device via an app.

RS-485: Hard wire CORAYVAC® Modulating Heating Control directly to your computer.

12.3 CORAYVAC® Modulating Thermostat

For a CORAYVAC® Modulating system, combine a modulating thermostat, a thermostat relay (P/N 90436300) and any one of the existing ROBERTS GORDON® VFD assemblies. The result will be a one pump, one zone CORAYVAC® Modulating system. The system will modulate based on the temperature sensed at the modulating thermostat, not outdoor

temperature. The modulating controls offer many features like 7 day programmability, four time periods per day (2 occupied, 2 unoccupied), temporary temperature setpoint override, keypad lockout security and more.

Remote sensors or outdoor sensors are optional, not required. Remote sensors will allow for zone temperature averaging, if required.

12.3.1 Analog Signal Modulating Thermostat

A programmable, 7-day programming, modulating thermostat can be installed to supply an analog (4-20mA) or (2-10Vdc with 500 Ohm resistor) control signal to dictate the speed of the pump. For thermostat wiring, See Page 62, Figure 46. Optional room sensors (P/N 10081520) and outdoor air sensors (P/N 10081521) are available.

Room temperature averaging networks can be

Table 3: Modulating Thermostat Cable Requirements

Wire Function	Recommended Wire Size (Minimum)	Specification or Requirement	Distance (Maximum)
Digital Outputs	18 AWG (0.75 sq mm)	Standard thermostat wire	1000 ft (304 m)
Modulating Outputs	18 AWG (0.75 sq mm)	1 pair	500 ft (152 m)
Outdoor Air Temperature Sensor	18 AWG (0.75 sq mm)	1 pair	500 ft (152 m)
Remote Sensor	18 to 22 AWG (0.75 to 0.34 sq mm)	Twisted pair wire	1000 ft (304 m)
Power Wiring	18 to 14 AWG (0.75 to 2.0 sq mm)	NEC Class II 140°F (60°C)	Limited by line-loss effects on power consumption.
LonWorks® (P/N 90425104 only)	18 AWG (0.75 sq mm) nonshielded	1 pair	Refer to E-bus Wiring Guide 74-2865 for maximum length and generic cable specifications.

12.3.3 Sequence of Operation

Depending on the space temperature, the thermostat will control the heat output based on demand signal communicated from the thermostat program. The thermostat will close contact on the transformer relay (P/N 90436300). The VFD run command is energized by the transformer relay. When the VFD energizes the pump and the vacuum has been established, the pressure switch will close and energize the burners. At high heat, a demand signal will turn the pump speed to a maximum frequency and burner(s) ON at maximum firing rate. As the space temperature gets closer to the set point, the thermostat program will slow the pump speed and burner(s) firing rate down until the room temperature reaches the thermostat set point.

NOTE:

To obtain Analog 0-10VDC signal, connect as shown on Page 71, Section 15.2 and set standard speed source (parameter 05 inside VFD menu) to 03.

created with up to nine room sensors (P/N 10081520). Refer to thermostat installation instructions for wiring.

12.3.2 Cable Requirement

Table 3, on on Page 55 lists wiring types, sizes and distances for modulating thermostat communication.

Power Requirement

Programmable thermostats requires 24 volt, AC power.

12.4 DPDT Transformer Relay (P/N 90436300)

The transformer relay wiring diagram is shown on Page 58, Figure 41. The transformer relay can be used to control an EP-100 or EP-201 pump CORAYVAC® system. The double pole relay can be used to control one or two zones of burners. The electrical circuit is a 120 V AC (20 A) supply. The transformer 24 V AC output for the thermostat is rated at 40 VA. Thermostats used with the transformer must not exceed this power requirement. A transformer relay operated system will not give any post purge pump operation to completely exhaust products of combustion from the system or provide indication of operating conditions.

FIGURE 39: One Zone Operation without Control Panel (optional)

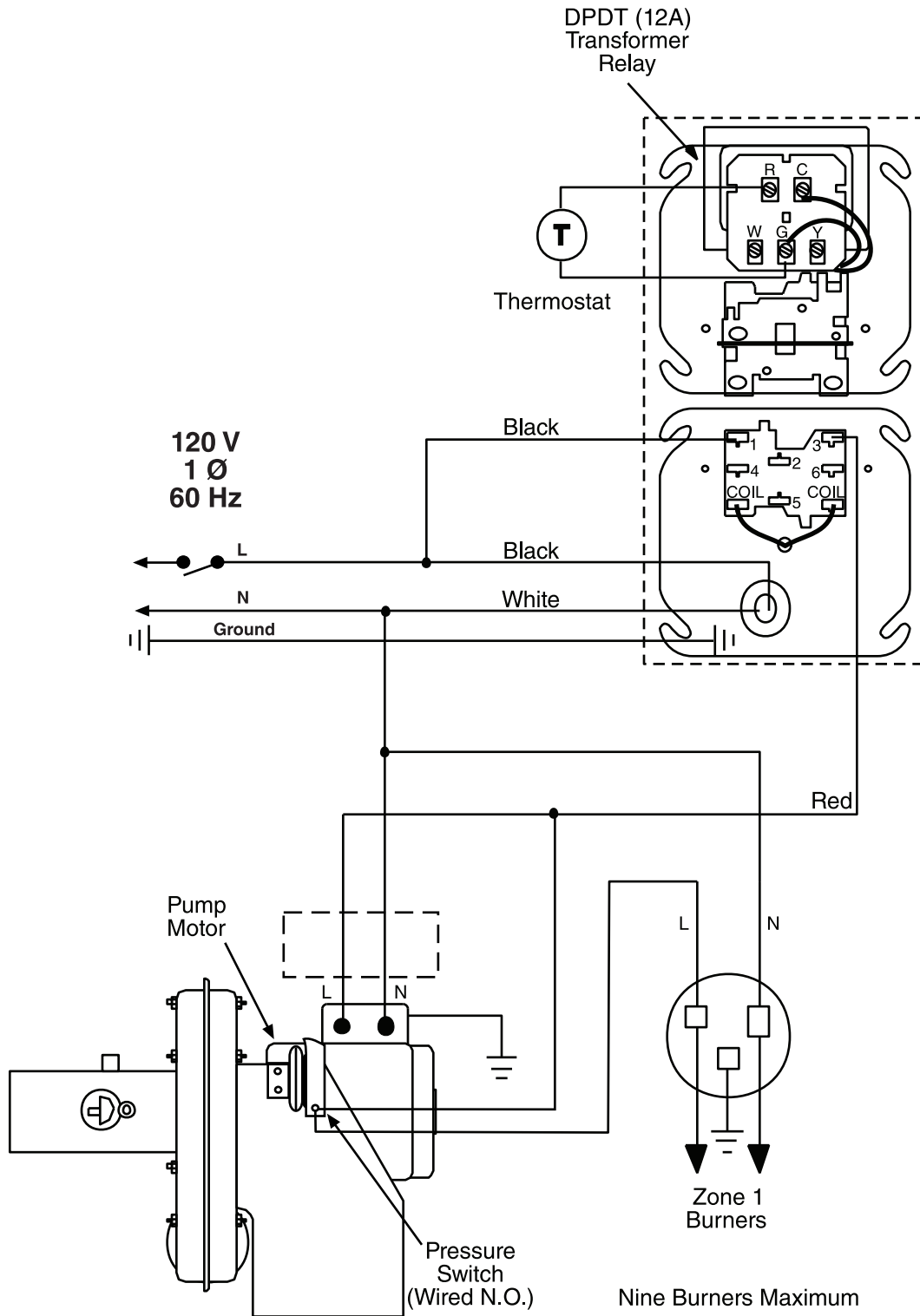

Description	Part Number
DPDT Transformer Relay	90436300

FIGURE 40: One Zone Operation (with Outside Air Blower) without Control Panel (optional)

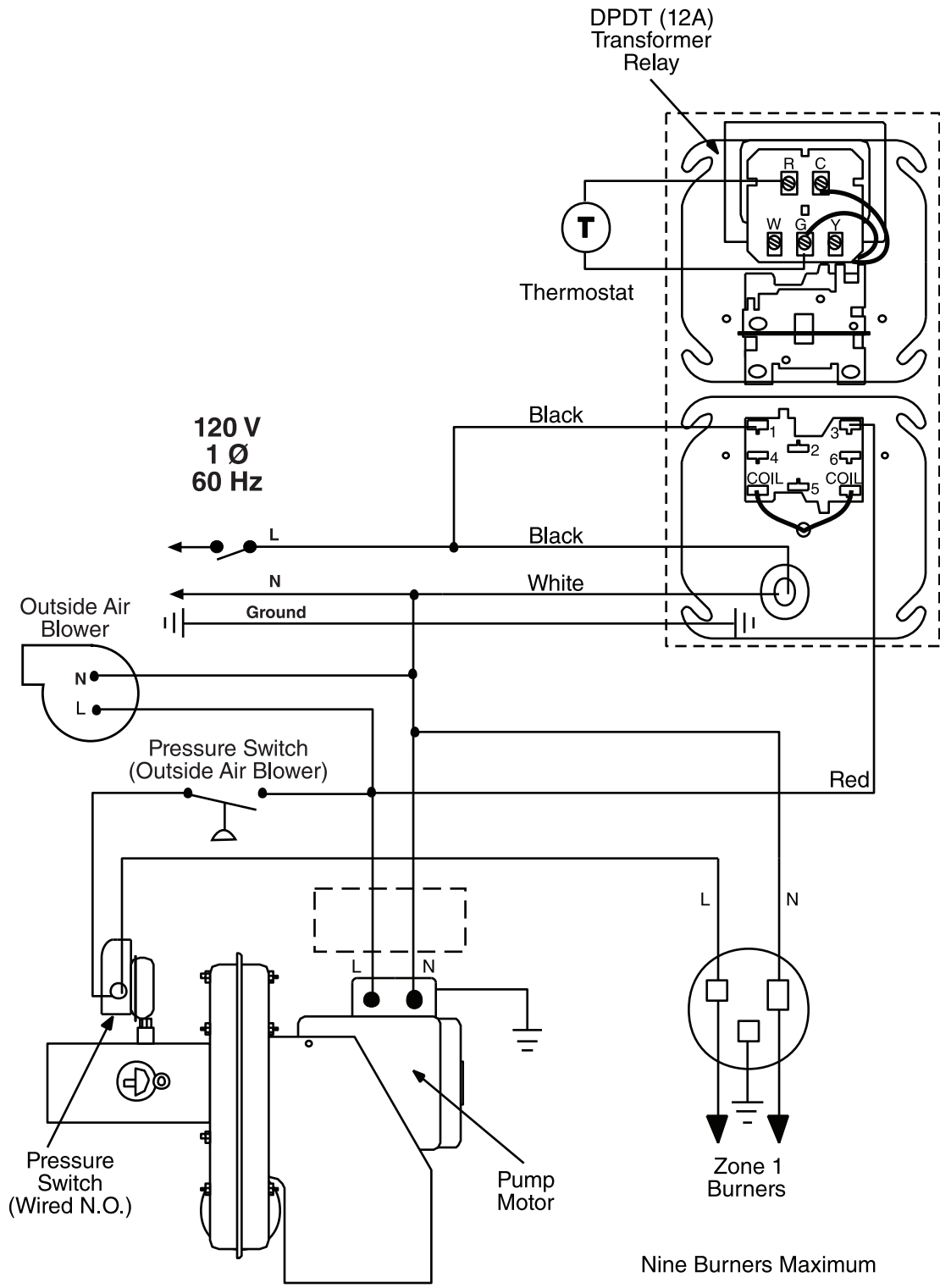

Description	Part Number
DPDT Transformer Relay	90436300
Blower Outside Air	90707501K

FIGURE 41: Two Zone Operation without Control Panel (optional)

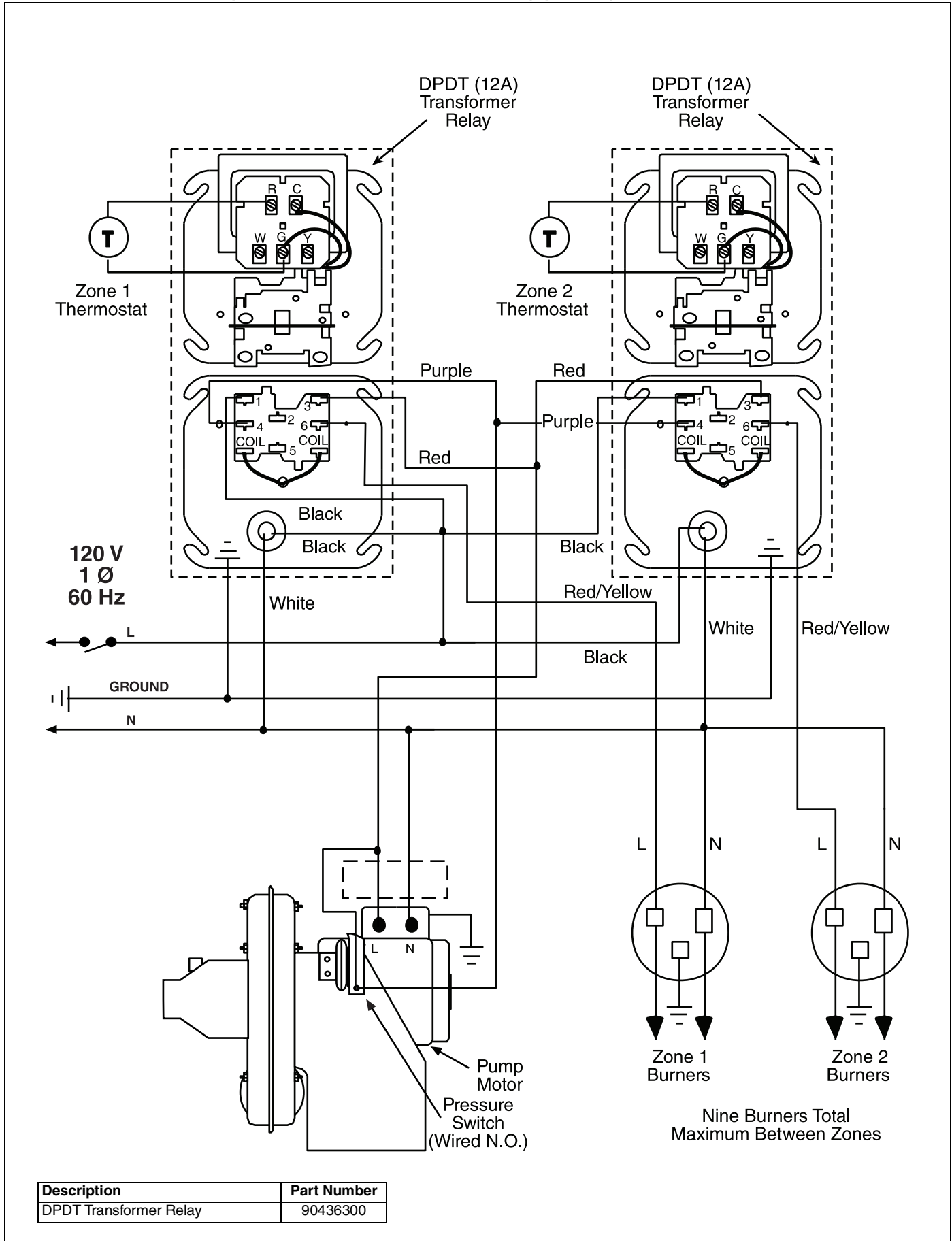

FIGURE 42: General System Wiring

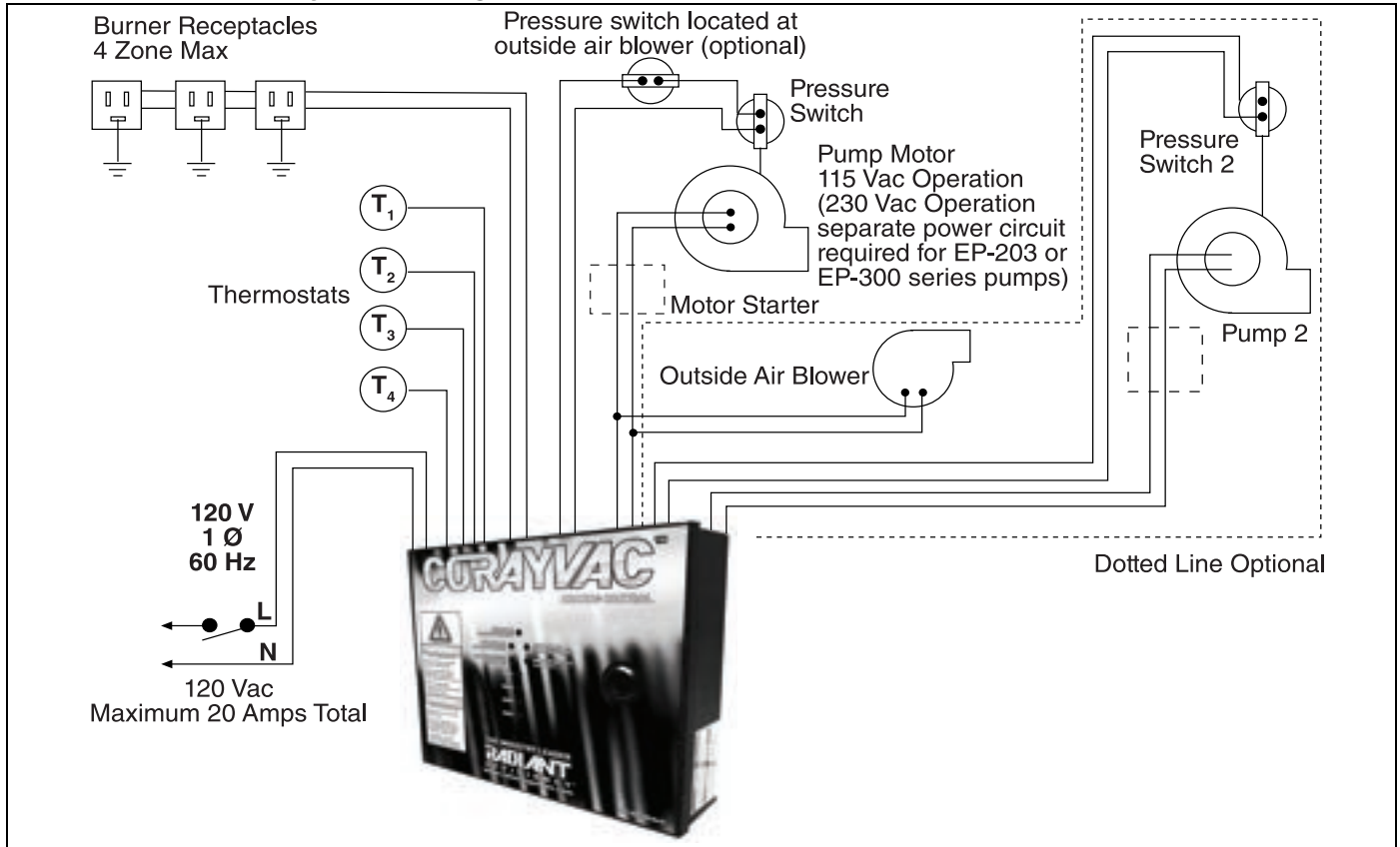

FIGURE 43: External Wiring Diagram EP-100 and EP-201 120 V 1 Ø Pump

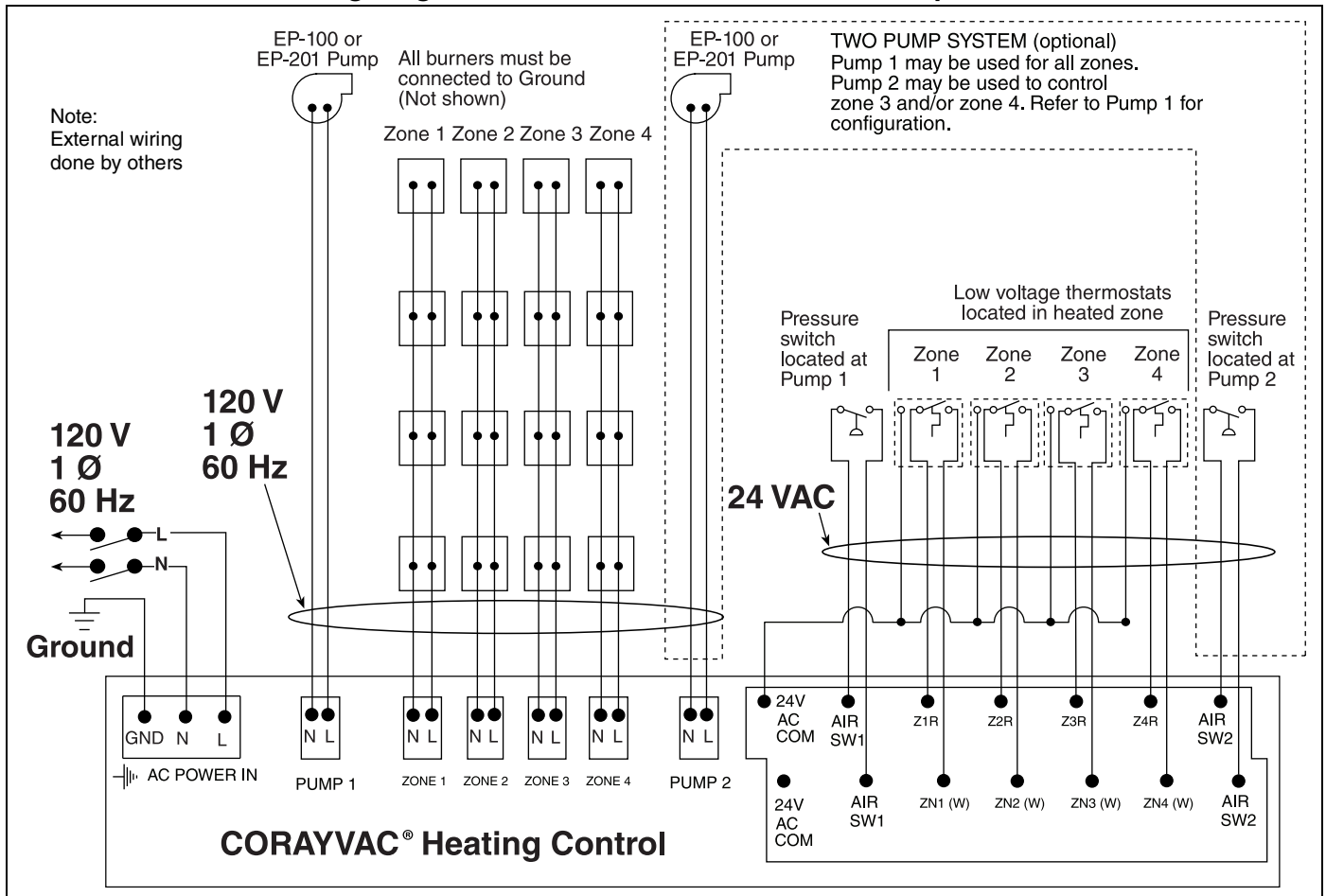

FIGURE 44: External Wiring Diagram EP-100, EP-201 or EP-301 230 V 1 Ø Pump (optional)

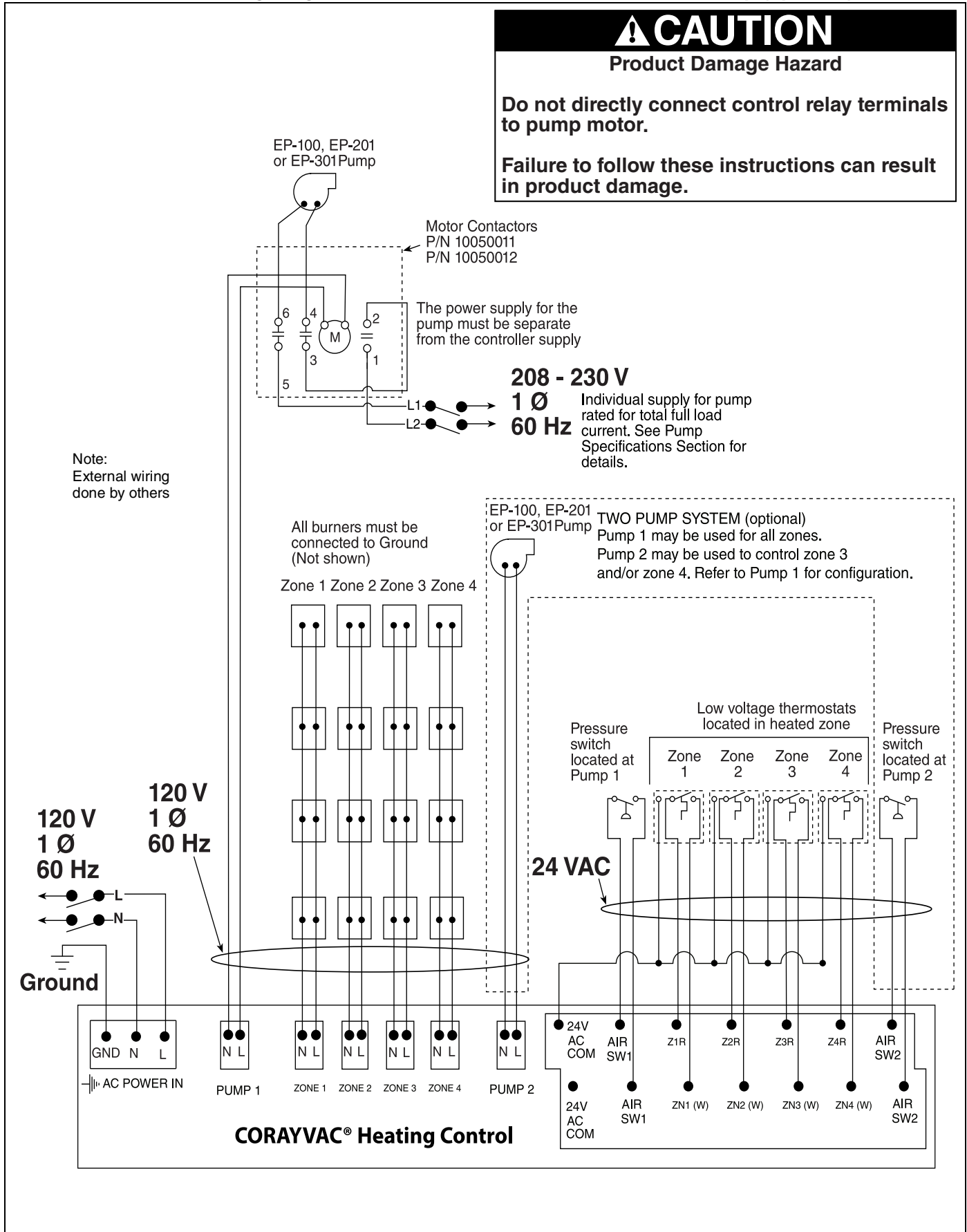

FIGURE 45: External Wiring Diagram EP-203 or EP-303 208 - 230 V (or 460 V) 3 Ø Pump (optional)

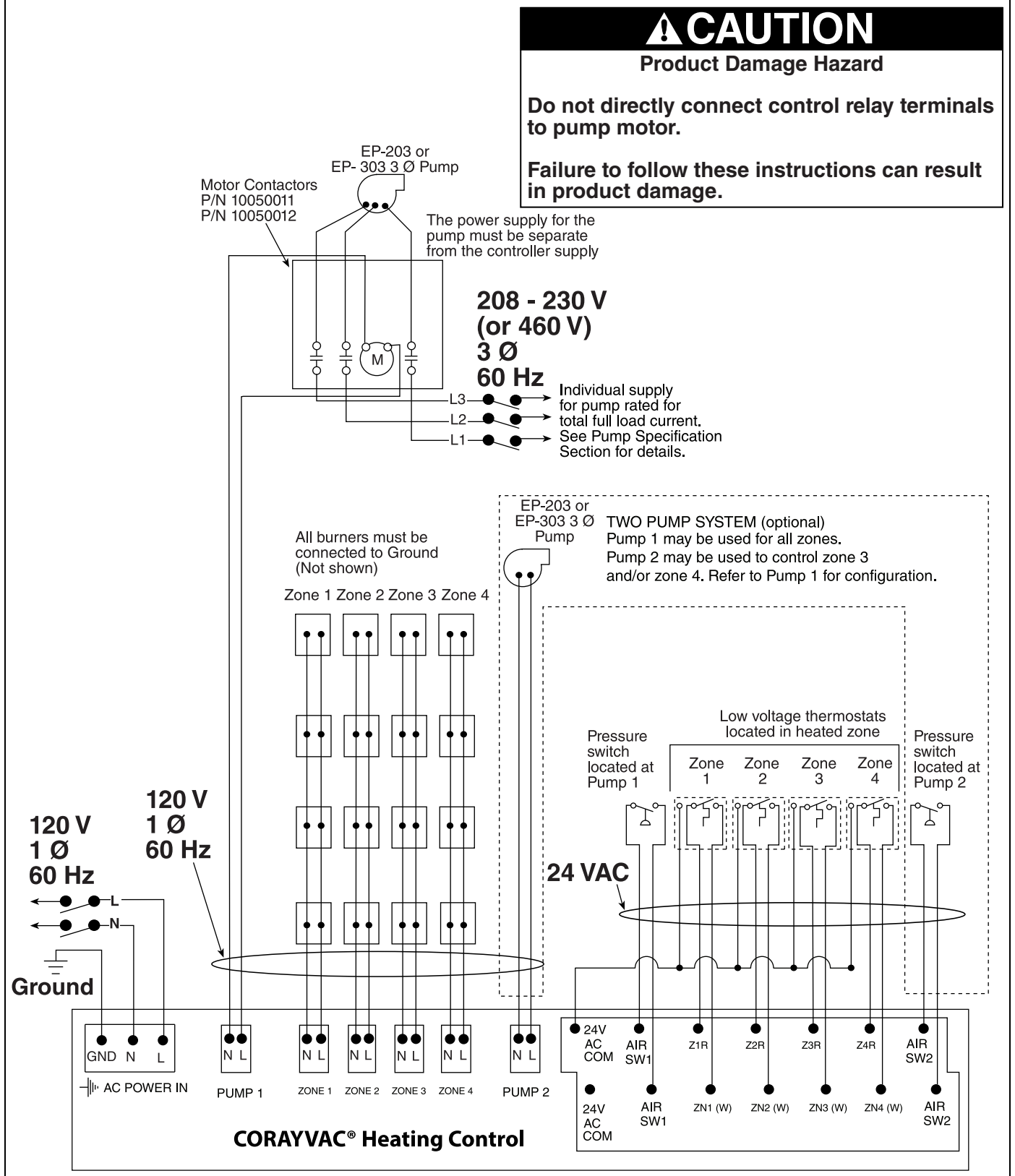

FIGURE 46: CORAYVAC® Modulating Wiring Diagram [LonWorks® (2-10 Vdc with 500 ohm resistor) optional]

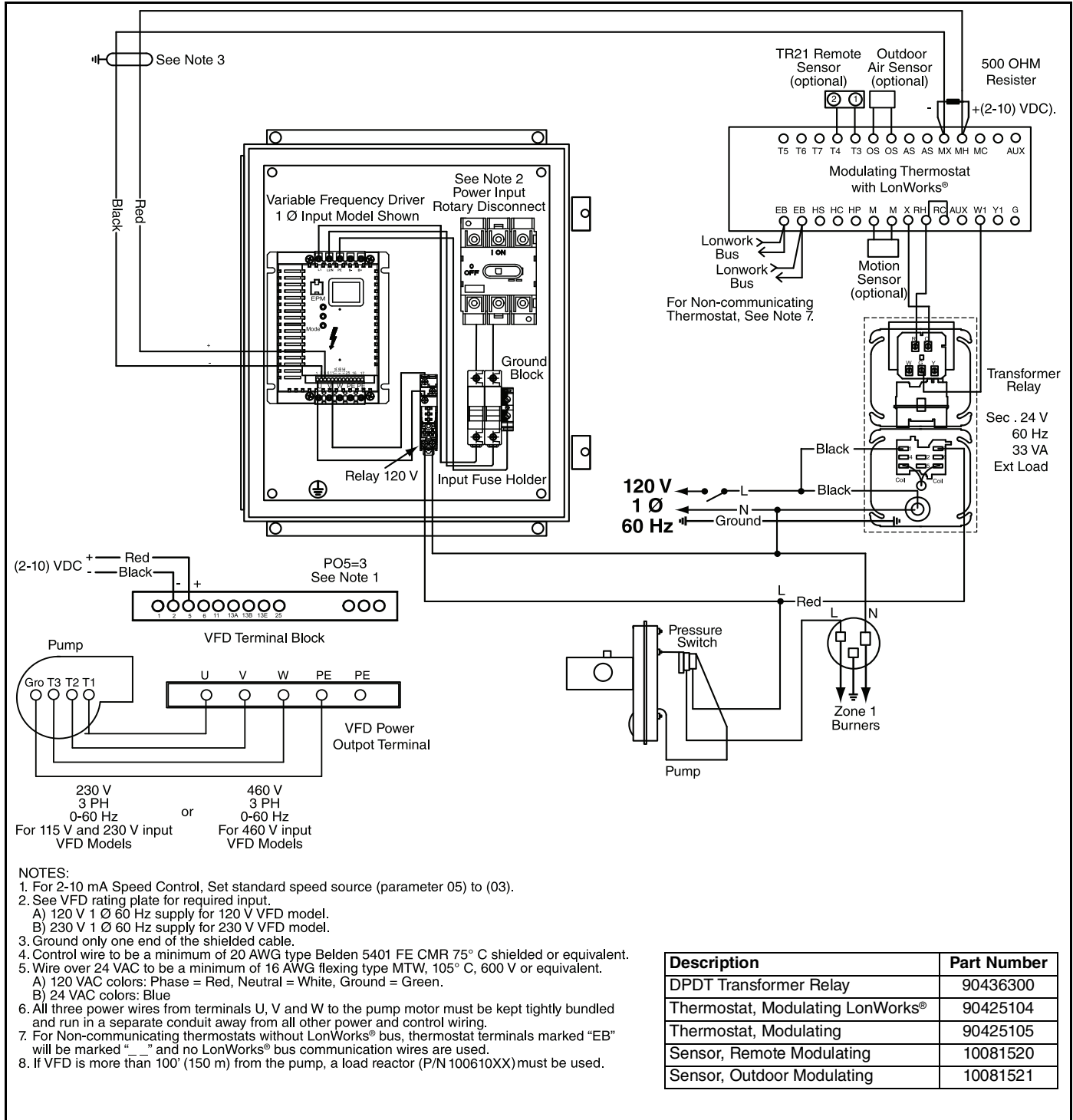

FIGURE 47: CORAYVAC® Modulating Wiring Diagram [LonWorks® (4-20 mA) optional]

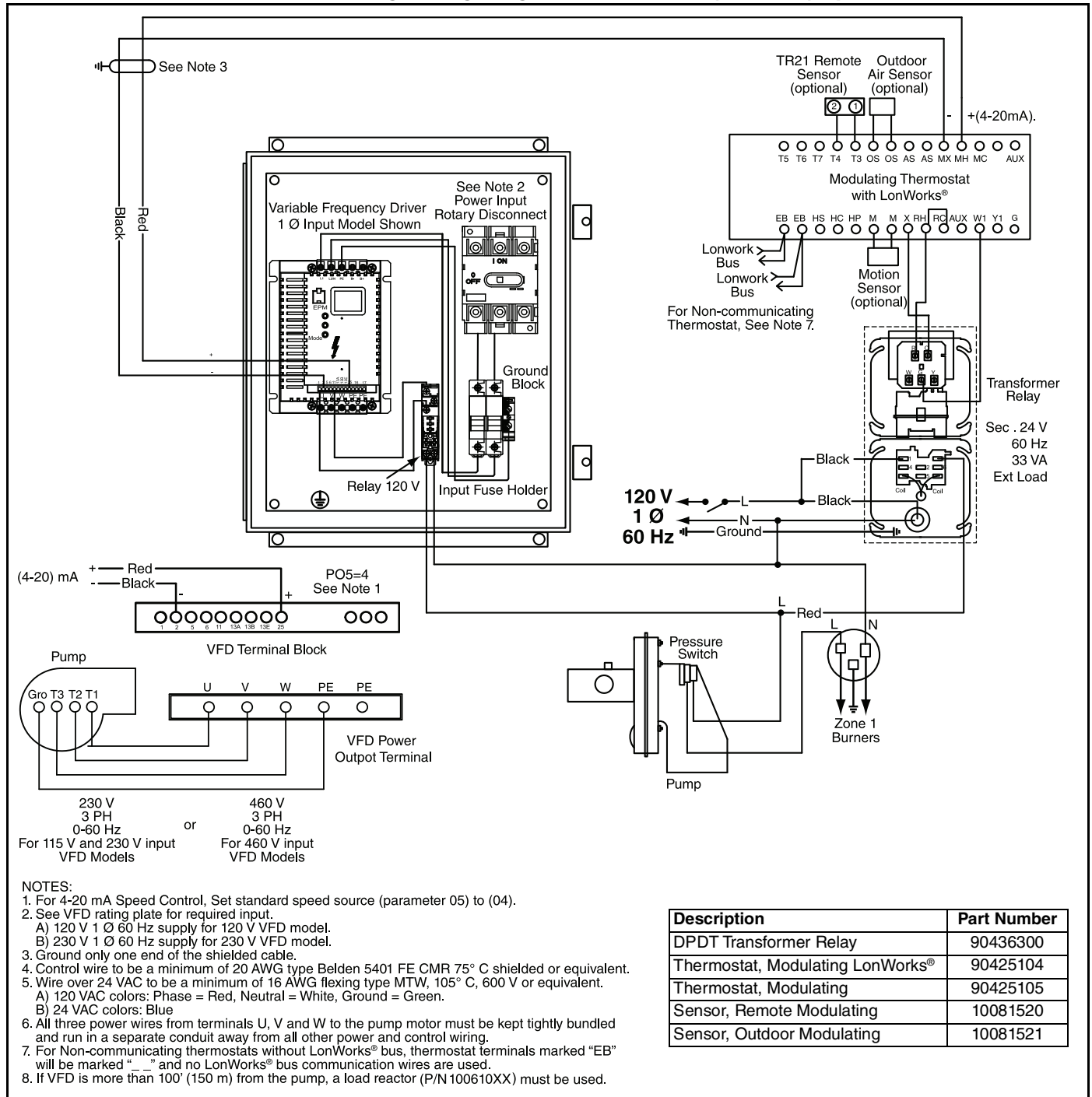
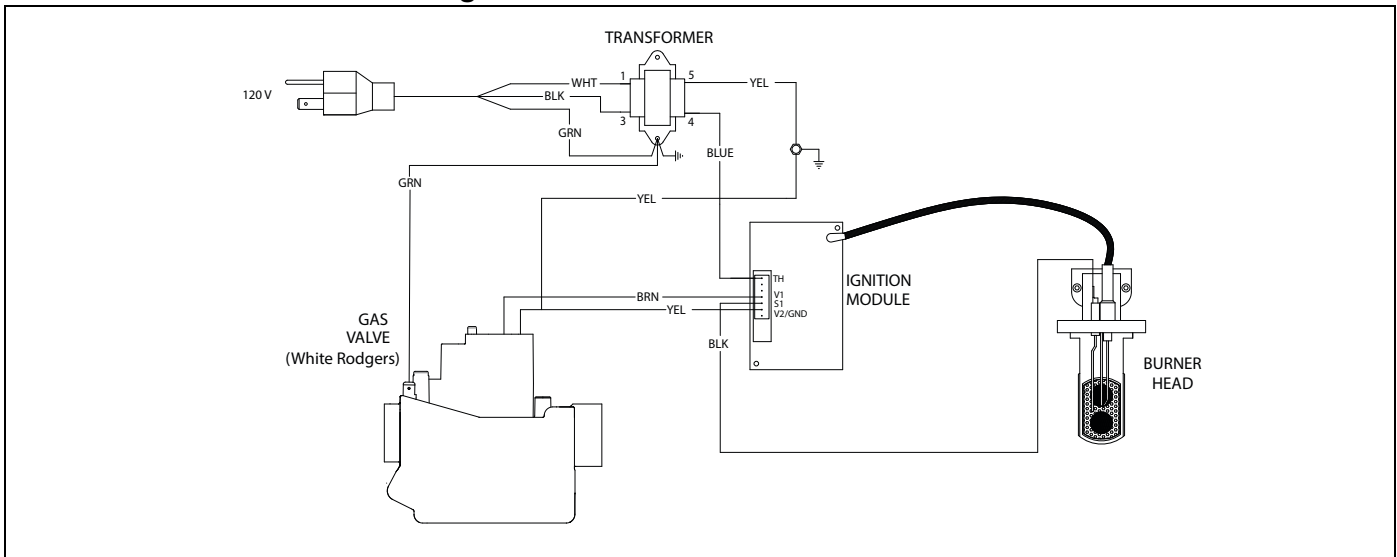
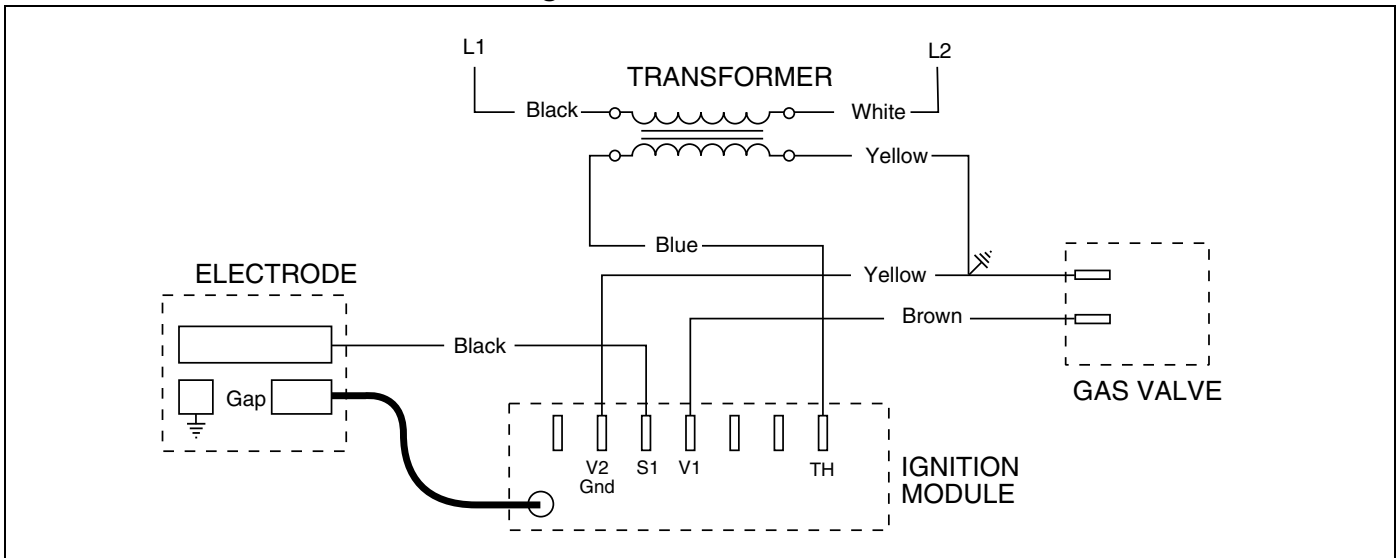

FIGURE 48: Burner Internal Wiring







If any of the original wire as supplied with the heater must be replaced, it must be replaced with wiring material having a temperature rating of at least 105°C and 600 volts.

FIGURE 49: Burner Internal Ladder Diagram



SECTION 13: STARTING THE SYSTEM

⚠ DANGER		⚠ WARNING	
			
Electrical Shock Hazard	Explosion Hazard	Carbon Monoxide Hazard	Burn Hazard
<p>Disconnect electric before service.</p> <p>More than one disconnect switch may be required to disconnect electric from heater.</p> <p>Heater must be connected to a properly grounded electrical source.</p>	<p>Leak test all components of gas piping before operation.</p> <p>Gas can leak if piping is not installed properly.</p> <p>Do not high pressure test gas piping with equipment connected.</p>	<p>Heaters installed unvented must be interlocked with sufficient building exhaust.</p> <p>Heaters must be installed according to the installation manual.</p>	<p>Allow heater to cool before service.</p> <p>Tubing may still be hot after operation.</p>
Failure to follow these instructions can result in death, electric shock, injury or property damage.			

Start with the main gas valve closed and the electric power off.

13.1 Checking the Gas Line

1. Open the main valve and verify that no gas is flowing through the meter.
2. Purge the line if this was not done following pressure testing with air.
3. Verify that the gas pressure is not above 14" wc (1/2 PSIG).
4. Close the main gas valve.

13.2 Checking the Electrical System

1. See that all temperature setpoints are set below room temperature.
2. Turn on power supply to system controls.
3. Check to see that no part of the system (i.e. burners, pump or air supply blower) is powered.
4. Individually check each zone by raising the zone temperature set points separately. Raising each zone temperature set point above room temperature should start the pump immediately. After a 45 second delay, the burners will begin their ignition sequence by sparking at the electrode (visible through the burner window). start. When the burner ignites, a blue flame will

5. Vacuum pump motors can be wired to rotate the impeller in either direction. A negative pressure can still be measured when the impeller is running backwards. An arrow is affixed to the outside of the pump scroll to indicate the direction of rotation of the impeller. Ensure proper rotation of the impeller prior to setting the vacuum pressure.
6. Make a preliminary vacuum check at burners in branches that have an adjustable damper coupling. See Page 67, Figure 50 for manometer hookup to check vacuum. This check is to insure that all dampers are open before the system is fired. Vacuum, as measured at the end vents, should be approximately 3.5" wc or slightly above (cold).

13.3 Starting the System

NOTE: During the initial firing, the protective oil on the tubing may smoke for 30 to 60 minutes and adequate ventilation should be provided.

1. Start with all temperature setpoints below room temperature.
2. Open main gas valve.
3. Turn up temperature setpoints one zone at a time, waiting to see that all burners in a zone be observed through the viewer window.

4. If any abnormal operation occurs, see the troubleshooting section of the service instructions.

13.4 Setting the Vacuum

1. Set temperature setpoints above room temperature. See that all burners are operating properly.
2. Allow at least $\frac{1}{2}$ hour operation for temperature to normalize, then check system vacuum balance. Vacuum can be measured by inserting a manometer hose into the end vent as shown *on Page 67, Figure 50*. Normal end vent vacuum should be set at approximately 2.5" wc to 3.0" wc (hot).

Vacuum adjustments are made by means of the damper in the pump inlet and the adjustable damper coupling(s) in the system. Check the vacuum at all end vents and then adjust the damper coupling to obtain equal vacuum readings of 2.5" wc to 3.0" wc. If end vent vacuum exceeds 3.0" wc, adjust the pump inlet damper until vacuum readings are 2.5" wc to 3.0" wc.

With systems designed to operate at maximum vacuum, it may not be possible to obtain vacuum differential readings at or slightly above 2.5" wc. If so, adjust the damper couplings to maximum but equal vacuum reading. Be sure to lock all dampers securely after adjustment.

3. Reset temperature setpoints to desired room temperature.
4. If heat is not required, turn off main switch and close the main gas valve.

FIGURE 50: Vacuum Reading

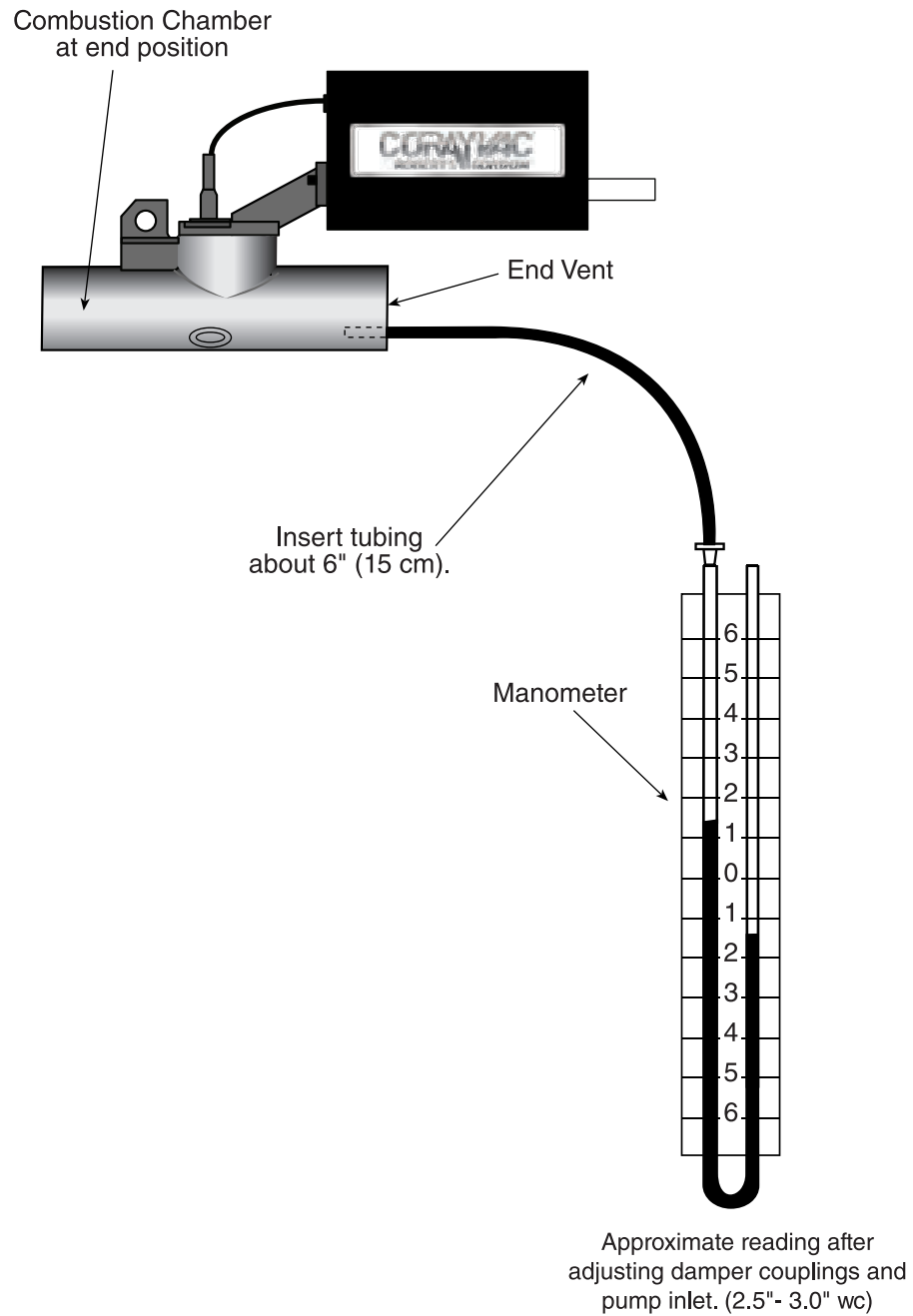

**SECTION 14: VARIABLE FREQUENCY DRIVE PROGRAMMING FOR USE WITH CORAYVAC®
MODULATING HEATING CONTROL**

**14.1 VFD Parameter Settings For Use With
CORAYVAC® Modulating Heating Control**

The VFD parameters come with factory default settings. The following parameter settings must be changed. Settings can only be altered when the pump motor is stopped.

Verify that there is power to the VFD (LCD display will be on) and is set to off.

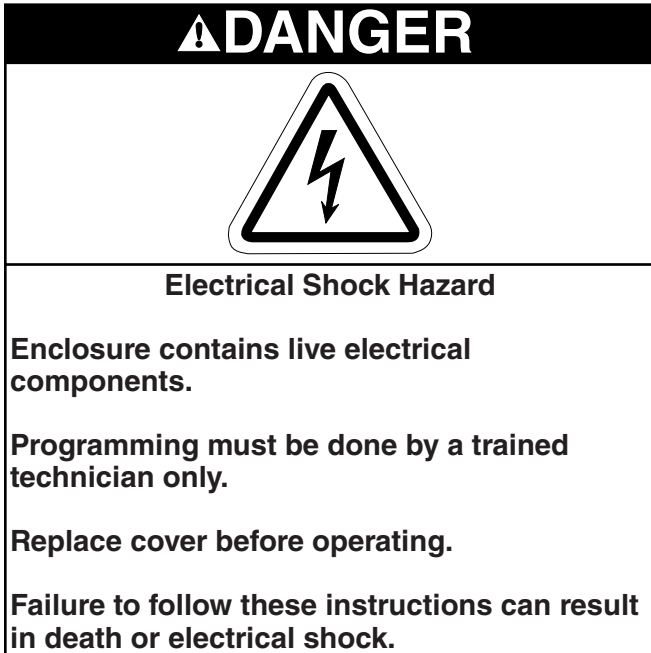

To override the rotary disconnect switch inside the VFD enclosure, turn the square rod with a wrench to the ON position. In order to be able to close the cover of the disconnect, the rods need to be turned back to the OFF position.

14.1.1

To enter the PROGRAM mode and access the parameters, hold "OK" until P01 appears.

Display reads "P01"

14.1.2

Use the arrow buttons to scroll to P14 (the factory set password is 0.0).

Press "OK" to enter password (101).

Once the correct password value is entered, the display will read "P14", which indicates that the PROGRAM mode has been accessed at the beginning of the parameter menu (P01 is the first

parameter).

14.1.3 Use the arrow buttons to scroll to the desired parameter number. For new parameter settings See *Page 69, Section 14.2.*

14.1.4 Once the desired parameter number is found: Press "OK" to display present parameter setting (example setting is 20.0).

Use arrow buttons to change setting.

Press "OK" to store new setting and exit the program mode.

14.1.5 To change another parameter, press the "OK" key again to re-enter the PROGRAM mode (the parameter menu will be accessed at the parameter that was last viewed or changed before exiting).

14.2 Altering VFD Parameters For Use With CORAYVAC® Modulating Heating Control

Using the procedure described on Page 68, Section 14.1.1 through Section 14.1.5, alter the following parameters:

Parameter Number	Parameter Name	Factory Default	New Setting
P01	Maximum Frequency (Hz)	50.0	60.0 (After setting initial frequency, set Maximum Frequency (Hz) according to instructions described in CORAYVAC® Modulating Heating Control installation and operation manual (P/N 1006101NA))
P02	Minimum Frequency (Hz)	0.0	40.0 (After setting initial frequency, set Minimum Frequency (Hz) according to instructions described in CORAYVAC® Modulating Heating Control installation and operation manual (P/N 1006101NA))
P03	Accel. Time (sec)	5	10
P04	Decel. Time (sec)	5	10
P07	Nominal Motor Voltage (V)	230*	Motor Voltage (from Motor Data Plate)
P08	Rated Motor Current (A)	4.8	Rated Motor Current (from Motor Data Plate)
P09	Rated Motor Frequency (Hz)	50.0	Rated Motor Frequency (from Motor Data Plate)
P12	Control Level	0.0	1 - Manual Run Mode 3 - Modbus (internal ramp times)**
P14***	VFD Access Code	0.0	101
P36	Communication Configuration	-	VFD Slave Address (1) or (2)
		-	Modbus RTU baud Rate (9.6)
		-	Time Out (0)

*Depends on the VFD rated power

**VFD should be in modbus mode unless manual mode is desired temporarily

***Parameter Number P14 set to 101 unlocks parameters P15-P53

SECTION 15: VARIABLE FREQUENCY DRIVE PROGRAMMING FOR USE WITH CORAYVAC® SYSTEM WITH MODULATING THERMOSTAT

15.1 VFD Parameter Settings For Use With Modulating Thermostats

The VFD parameters come with factory default settings. The following parameter settings must be changed for modulating thermostats. Settings can only be altered when the pump motor is stopped.

Verify that there is power to the VFD (LCD display will be on) and modulating thermostat is set to off.

⚠ DANGER



Electrical Shock Hazard

Enclosure contains live electrical components.

Programming must be done by a trained technician only.

Replace cover before operating.

Failure to follow these instructions can result in death or electrical shock.

To override the rotary disconnect switch inside the VFD enclosure, turn the square rod with a wrench to the ON position. In order to be able to close the cover of the disconnect, the rods need to be turned back to the OFF position.

15.1.1

To enter the PROGRAM mode and access the parameters, press the Mode button. This will activate the PASSWORD prompt (if the password has not been disabled).

Display reads "00"

Upper right decimal point blinks

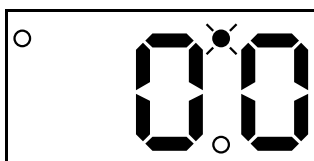

15.1.2

Use the arrow buttons to scroll to the password value

(the factory set password is 225).

Press Mode to enter password.

Once the correct password value is entered, the display will read "P01", which indicates that the PROGRAM mode has been accessed at the beginning of the parameter menu (P01 is the first parameter).

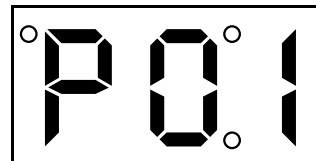

NOTE: If the display flashes "Er", the password was incorrect, and the process to enter the password must be repeated.

15.1.3 Use the arrow buttons to scroll to the desired parameter number. For new parameter settings See Page 69, Section 14.2.

15.1.4 Once the desired parameter number is found:

Press Mode to display present parameter setting (example setting is 20.0).

Upper right decimal point blinks.



Use arrow buttons to change setting.

Press Mode to store new setting and exit the program mode.

15.1.5 To change another parameter, press the Mode key again to re-enter the PROGRAM mode (the parameter menu will be accessed at the parameter that was last viewed or changed before exiting).

If the Mode key is pressed within two minutes of exiting the PROGRAM mode, the password is not required to access the parameters. After two minutes, the password must be entered in order to access the parameters again.

15.2 Altering VFD Parameters For Use With CORAYVAC® System With Modulating Thermostat

Using the procedure described on *Page 68, Section 14.1.1 through Section 14.1.5, Page 70, Section 15.1 through Page 70, Section 15.1.5*, alter the following parameters:

Parameter Number		Parameter Name		Factory Default		New Setting	
AC-Teck	Lenze	AC-Teck	Lenze	AC-Teck	Lenze	AC-Teck	Lenze
P01	P107	Line Voltage		01	01	01	01
P03	P110	Start Method		01	0	05	05
P05	P101	Standard Speed Source		01	0.0	(03) (0-10)VDC (04) (4-20)mA	(01) for 0-10VDC (02) for 4-20 mA
P44	P194	Password		225	0.0	Any# 000-999	Any# 0000-9999
P45	P102	Speed at Minimum Signal		0.0	0.0	Frequency Setting Noted on <i>Page 72</i> , <i>Section 16</i>	Frequency Setting Noted on <i>Page 72</i> , <i>Section 16</i>
P46	P103	Speed at Maximum Signal		60.0	60.0	Frequency Setting Noted on <i>Page 72</i> , <i>Section 16</i>	Frequency Setting Noted on <i>Page 72</i> , <i>Section 16</i>

SECTION 16: COMMISSIONING THE CORAYVAC® MODULATING SYSTEM

NOTE: Before starting the commissioning procedure, all the wiring of the CORAYVAC® Modulating Heating Control control boards, relay boards, modulating thermostats, pumps and VFD must be completed. The communication connection must be made to the controller, modulating thermostat and burners. The CORAYVAC® Modulating Heating Control software must be installed on the PC.

It is important to understand that the frequency that the VFD runs the motor at, determines the speed of the impeller in the pump. Variation of the impeller speed will increase or decrease vacuum in the system. The following procedure will help you set minimum and maximum VFD frequency settings to achieve proper vacuum in the system.

16.1 Setting The CORAYVAC® End Burner Vacuum

16.1.1 CORAYVAC® Modulating Heating Control

For complete CORAYVAC® Modulating Heating Control installation please refer to the CORAYVAC® Modulating Heating Control Installation, Operation and Service Manual (P/N 1006101NA), latest edition.

16.1.2 Modulating Thermostat

Turn on power to the VFD and transformer relay; this should energize the modulating thermostat. Set the thermostat to "call for heat" as described in the accompanying instructions for the modulating thermostat. See Page 68, Section 14 for setting up the VFD.

16.2 Adjusting the Variable Frequency Drive

16.2.1 Maximum Signal Speed

The pump should be running and the burners should light within 60 seconds. At the VFD, verify the number displayed on the LCD screen is "60.0" If it is lower than 60.0, hit the "up" arrow button on the VFD until the number reads 60.0 Let the burners fire for approximately 20-30 minutes to warm up the system. Using a manometer, check the end vent vacuum in each zone (each branch of burners). See Page 73, Figure 51.

If the lowest end vent vacuum reading is above 3.0" wc, reduce the vacuum pump speed. Generally, the lowest end vent vacuum reading is on the longest branch of the system. Use the down arrow button on the VFD to reduce the frequency of the output signal to the pump, thus reducing the pump speed and lowering the end vent vacuum reading. Continue to

reduce the frequency until the end vent vacuum reading is between 2.5" - 3.0" wc. Make note of this frequency setting below. The frequency is found on the VFD's LCD screen.

2.5" wc - 3.0" wc VFD Frequency Setting

Record Frequency Setting Here:

NOTE: To avoid damage to the pump motor, do not adjust the frequency above 60.0 Hz. Verify that the end vent vacuum readings in the remaining branches are proper. If necessary, adjust the proper damper coupling to achieve an end vent vacuum of 2.5" - 3.0" wc, See Page 67, Figure 50. Damper couplings should be found near the end of the radiant portion of the pipe in each branch or where a branch connects to other branches at a cross or tee. See Page 73, Figure 51.

16.2.2 Minimum Signal Speed

After setting end vent vacuums between 2.5" wc and 3.0" wc, while all the burners are still operating, use the down arrow button on the VFD to reduce the frequency of the output signal to the pump. Reduce the frequency of the VFD until the manometer at each of the end vents reads 1.2" wc - 1.5" wc. Make note of this frequency setting below. The frequency is found on the VFD's LCD screen.

1.2" w.c. - 1.5" wc VFD Frequency Setting

Record Frequency Setting Here:



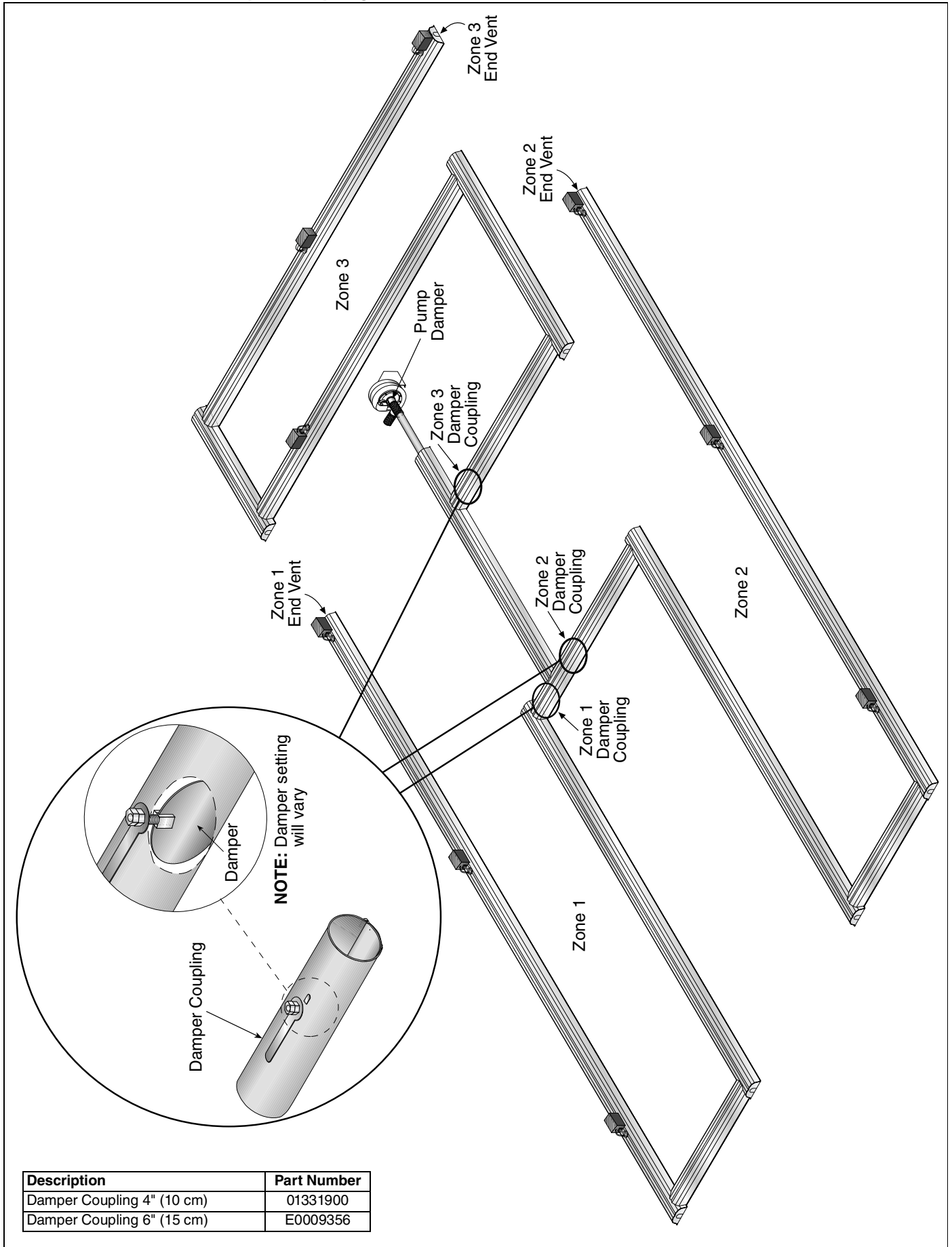

16.2.3 Modulating Thermostat

Turn "OFF" the power to the transformer relay. Using the procedure described on Page 68, Section 14, alter the parameters above on the VFD. Turn on the transformer relay and program the modulating thermostat to the customer's requirements.

FIGURE 51: Possible Damper Couplings' Locations

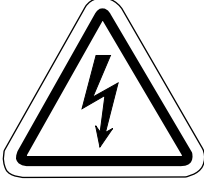

SECTION 17: OPERATION AND MAINTENANCE

⚠ DANGER		⚠ WARNING	
			
<p>Electrical Shock Hazard</p> <p>Disconnect electric before service.</p> <p>More than one disconnect switch may be required to disconnect electric from heater.</p> <p>Heater must be connected to a properly earthed electrical source.</p>	<p>Explosion Hazard</p> <p>Turn off gas supply to heater before service.</p>	<p>Burn Hazard</p> <p>Allow heater to cool before service.</p> <p>Tubing may still be hot after operation.</p>	<p>Cut/Pinch Hazard</p> <p>Wear protective gear during installation, operation and service.</p> <p>Edges are sharp.</p>
<p>Failure to follow these instructions can result in death, electric shock, injury or property damage.</p>			

The heater is equipped with a direct-spark ignition system.

(thermostat cycle is required) or automatically after 1 hour.

17.1 Sequence of Operation

1. Turn the thermostat up. When the thermostat calls for heat, the pump will start immediately. After a short period, the burners will begin their ignition sequence. Sparking will begin at the electrodes and the gas valve will be energized 45 seconds later.
2. The flame will be sensed by the flame sensing rod and the electrode is de-energized.
3. If a flame is detected, the gas valve remains open. When the call for heat is satisfied, the burner shuts off. On CRV-Series systems equipped with the optional CORAY-VAC® Heating Control, or CORAYVAC® Modulating Heating Control, the pump will continue operation for a post-purge period of two minutes.
4. If no flame is detected, the module will close and a purge period begins. If a flame is not established, a second purge and warm-up will take place and then a third trial cycle will begin. After three trials, the module will lockout for one hour or until reset.
5. A reset is accomplished by removing power from the module for at least 5 seconds

17.2 To Shut Off Heater

- Set thermostat to lowest setting.
- Turn OFF electric power to heater.
- Turn OFF manual gas valve in the heater supply line.

17.3 To Start Heater

- Turn gas valve and electric power OFF and wait five minutes for unburned gases to vent from heater.
- Turn ON main gas valve.
- Turn ON electric power.
- Set thermostat to desired temperature.
- Burner should light automatically.

17.4 Pre-Season Maintenance and Annual Inspection

To ensure your safety and years of trouble-free operation of the heating system, service and annual inspections must be done by a contractor qualified in the installation and service of gas-fired heating equipment.

Turn off gas and electric supplies before performing service or maintenance. Allow heater to cool before servicing.

Before every heating season, a contractor qualified in the installation and service of gas-fired heating equipment must perform a thorough safety

inspection of the heater.

For best performance, the gas, electrical, thermostat connections, tubing, venting, suspensions and overall heater condition should be thoroughly inspected.

NOTE: Gas flow and burner ignition are among the first things that should be inspected.

Please see *Page 75, Section 17.5* for suggested items to inspect.

All installation and service of ROBERTS GORDON® equipment must be performed by a contractor qualified in the installation and service of equipment sold and supplied by Roberts-Gordon LLC and conform to all requirements set forth in the ROBERTS GORDON® manuals and all applicable governmental authorities pertaining to the installation, service, operation and labeling of the equipment.

To help facilitate optimum performance and safety, Roberts-Gordon LLC recommends that a qualified contractor conduct, at a minimum, annual inspections of your ROBERTS GORDON® equipment and perform service where necessary, using only replacement parts sold and supplied by Roberts-Gordon LLC.

17.5 Maintenance Checklist





Installation Code and Annual Inspections:

The Vicinity of the Heater	Do not store or use flammable objects, liquids or vapors near the heating system. Immediately remove these items if they are present. <i>See Page 5, Section 3.</i>
Vehicles and Other Objects	Maintain the clearances to combustibles. Do not hang anything from, or place anything on, the heater. Make sure nothing is lodged underneath the reflector, in between the tubes or in the decorative or protective grilles (included with select models). Immediately remove objects in violation of the clearances to combustibles. <i>See Page 5, Section 3.</i>
Reflector	Support reflector with reflector hanger and support strap. Reflector must not touch tube. Make sure there is no dirt, sagging, cracking or distortion. Do not operate if there is sagging, cracking or distortion. Make sure reflectors are correctly overlapped. <i>See Page 27, Figure 7.3.3.</i> Clean outside surface with a damp cloth.
Vent Pipe	Venting must be intact. Using a flashlight, look for obstructions, cracks on the pipe or gaps in the sealed areas or corrosion. The area must be free of dirt and dust. Remove any carbon deposits or scale using a wire brush. <i>See Page 38, Section 9.</i>
Outside Air Inlet	Inlet must be intact. Look for obstructions, cracks on the pipe or gaps in the sealed areas or corrosion. The area must be free of dirt and dust. Clean and reinstall as required.
Tubes	Make sure there are no cracks. Make sure tubes are connected and suspended securely. <i>See Page 21, Figure 20 through Page 24, Section 7.2.1.</i> Make sure there is no dirt, sagging, bending or distortion. Clean or replace as required.

Gas Line	Check for gas leaks. See <i>Page 53, Figure 38</i> .
Combustion Chamber Window	Make sure it is clean and free of cracks or holes. Clean or replace as required.
Blower Scroll, Wheel and Motor	Compressed air or a vacuum cleaner may be used to clean dust and dirt.
Burner Head and Orifice	Clear of obstructions. (Even spider webs will cause problems). Carefully remove any dust and debris from the burner.
Electrode	Replace if there are cracked ceramics, excessive carbon residue, or erosion of the electrode. The electrode gap should be 1/8" (3 mm).
Thermostat or Sensor	There should be no exposed wire or damage to the thermostat or sensor. See <i>Page 54, Section 12</i> .
Suspension Points	Make sure the heater is hanging securely. Look for signs of wear on the chain or ceiling. See <i>Page 21, Figure 20</i> .
Filter	Check for dirt or dust. Clean or replace as required.
Decorative and Protective Grille (optional)	The grille must be securely attached. Check that side reflector extensions are installed correctly and secured in place if necessary. (Decorative grille only.) See <i>Page 35, Section 8.7.1 through Page 37, Section 8.8.3</i> Make sure shield is installed correctly and secured in place if necessary. (Decorative grille only.) See <i>Page 35, Section 8.7.2</i> .
Pump	With pump operating, check for excessive vibration or noise. Vibration is usually a sign that the impeller is out of balance. Turn off the system, insure power is shut off and remove the inlet plate. Check the shaft seal and replace it if worn or missing. With the Power off: Check the inlet and outlet of the pump for blockage or excessive soot and clean as necessary. Check boots for cracking or deterioration and replace if necessary. If a condensate trap is installed, check the condition of the trap and the drain line attached. Note: the condensate trap should be filled with water at the beginning of each heating season. Check the condition of the motor mounts. Lift the motor from the rear; look for breaks in the rubber and replace if necessary. Check the condition and operation of the pressure switch.
Wall Tag	If wall tag is present, make sure it is legible and accurate. Please contact Roberts-Gordon LLC or your ROBERTS GORDON® independent distributor, if you need a wall tag. See <i>Page 4, Section 2.1</i> .
Safety Labels	Product safety signs or labels should be replaced by the product user when they are no longer legible. Please contact Roberts-Gordon LLC or your ROBERTS GORDON® independent distributor to obtain replacement signs or labels. See <i>Page 2, Figure 1 through Page 3, Figure 2</i> .

SECTION 18: TROUBLESHOOTING

⚠ DANGER	
	
Electrical Shock Hazard	
Disconnect electric before service.	
More than one disconnect switch may be required to disconnect electric from heater.	
Heater must be properly grounded.	
Failure to follow these instructions can result in death or electrical shock.	

⚠ WARNING			
			
Fire Hazard	Explosion Hazard	Burn Hazard	Cut/Pinch Hazard
Keep all flammable objects, liquids and vapors the minimum required clearances to combustibles away from heater.	Turn off gas supply to heater before service.	Allow heater to cool before service.	Wear protective gear during installation, operation and service.
Some objects will catch fire or explode when placed close to heater.		Tubing may still be hot after operation.	Edges are sharp.
Failure to follow these instructions can result in death, injury or property damage.			

18.1 Troubleshooting Flow Chart

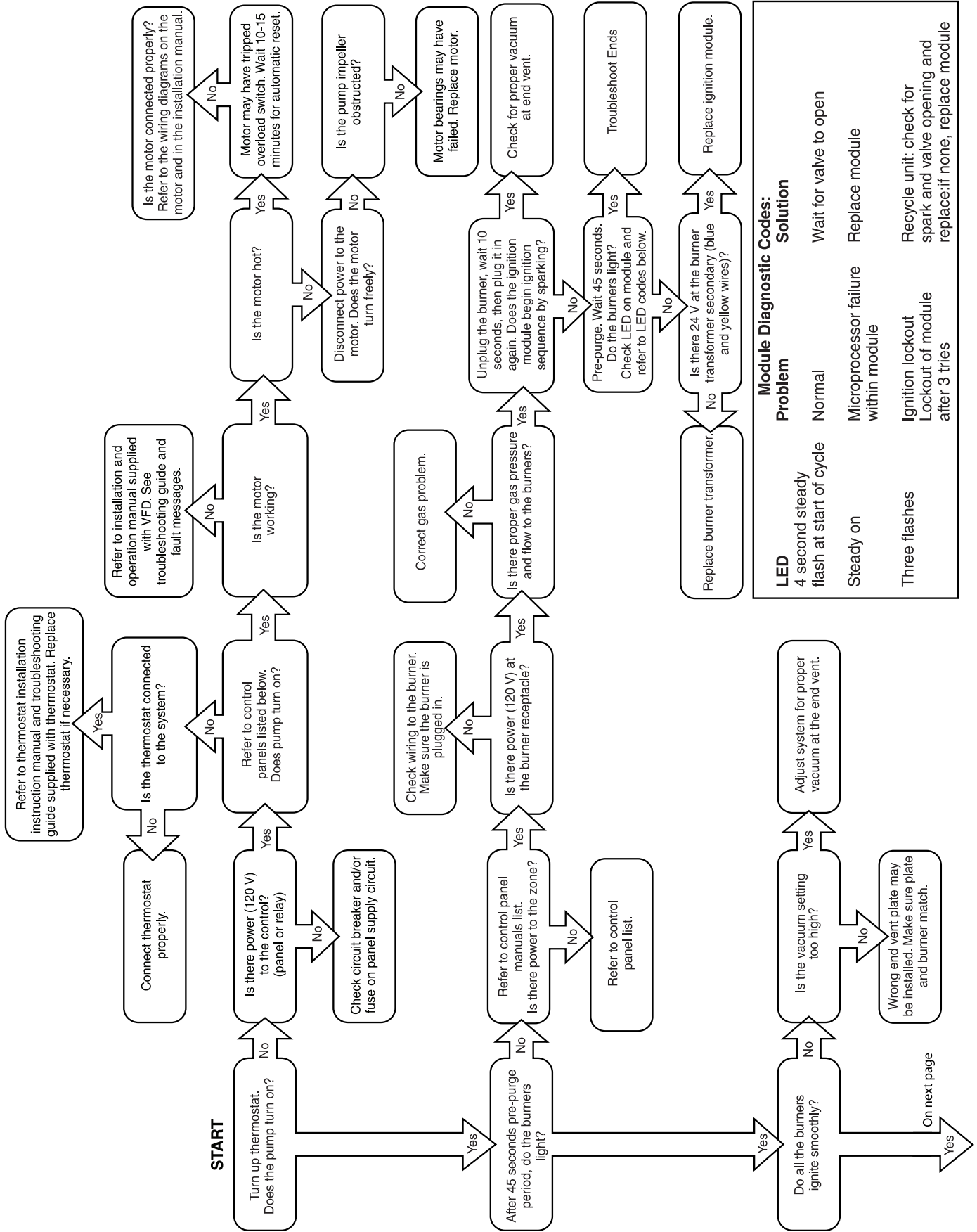



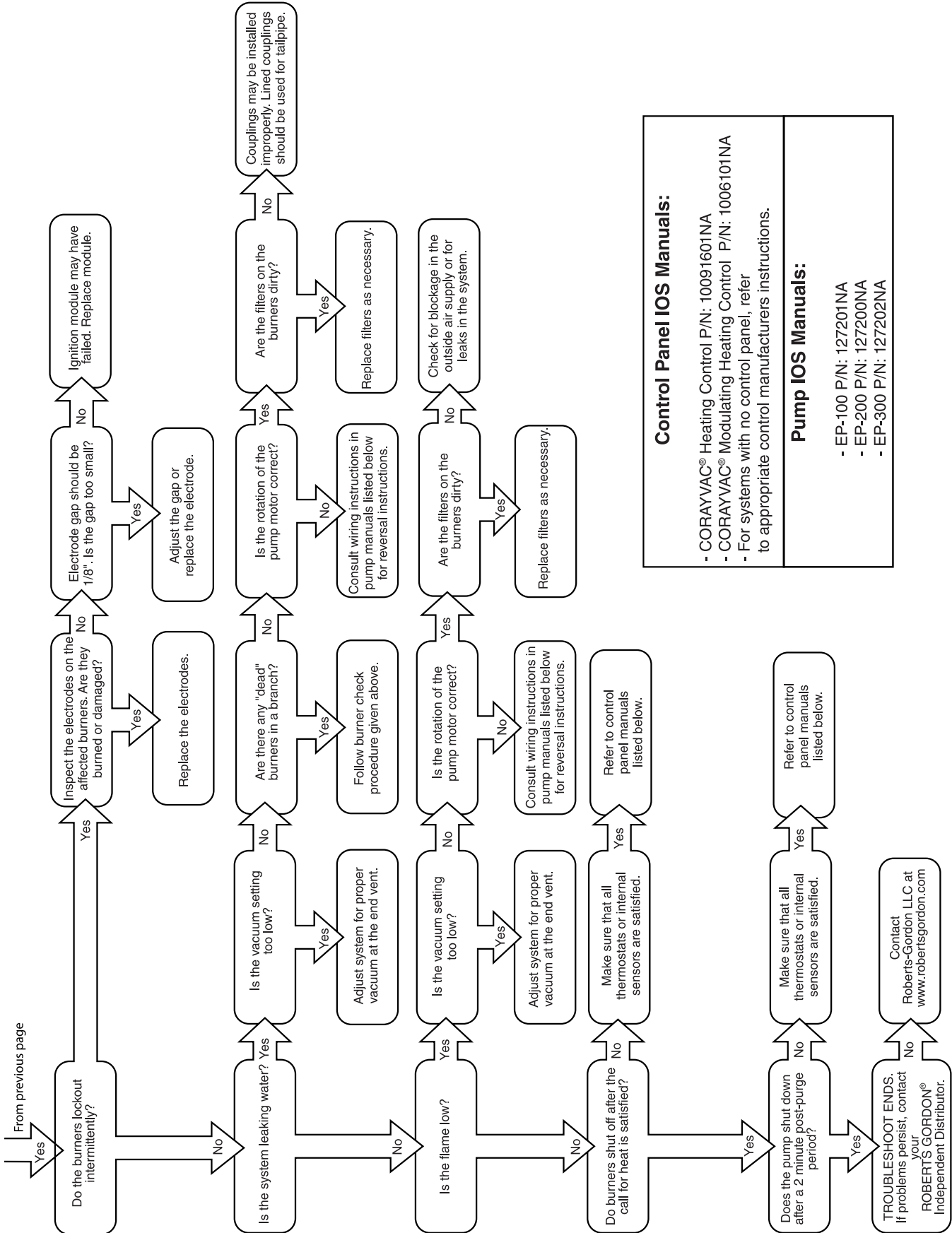

Module Diagnostic Codes:	
LED	Problem
4 second steady flash at start of cycle	Normal
Steady on	Microprocessor failure within module
Three flashes	Ignition lockout Lockout of module after 3 tries
Solution	
	Wait for valve to open
	Replace module
	Recycle unit: check for spark and valve opening and replace: if none, replace module

Troubleshooting Flow Chart



<p>Control Panel IOS Manuals:</p> <ul style="list-style-type: none"> - CORAYVAC® Heating Control P/N: 10091601NA - CORAYVAC® Modulating Heating Control P/N: 1006101NA - For systems with no control panel, refer to appropriate control manufacturers instructions.
<p>Pump IOS Manuals:</p> <ul style="list-style-type: none"> - EP-100 P/N: 127201NA - EP-200 P/N: 127200NA - EP-300 P/N: 127202NA

SECTION 19: REPLACEMENT PARTS

⚠ DANGER	⚠ WARNING		
			
Electrical Shock Hazard	Explosion Hazard	Fire Hazard	Carbon Monoxide Hazard
<p>Use only genuine ROBERTS GORDON® replacement parts per this installation, operation and service manual.</p> <p>Failure to follow these instructions can result in death, electric shock, injury or property damage.</p>			

See warnings and important information before removing or replacing parts. After any maintenance or repair work, always test fire the heater in accordance with the start-up instructions *on Page 65, Section 13* to help ensure all safety systems are in working order before leaving the heater to operate. Minor faults may be traced by using the troubleshooting charts *on Page 77, Section 18 through Page 77*.

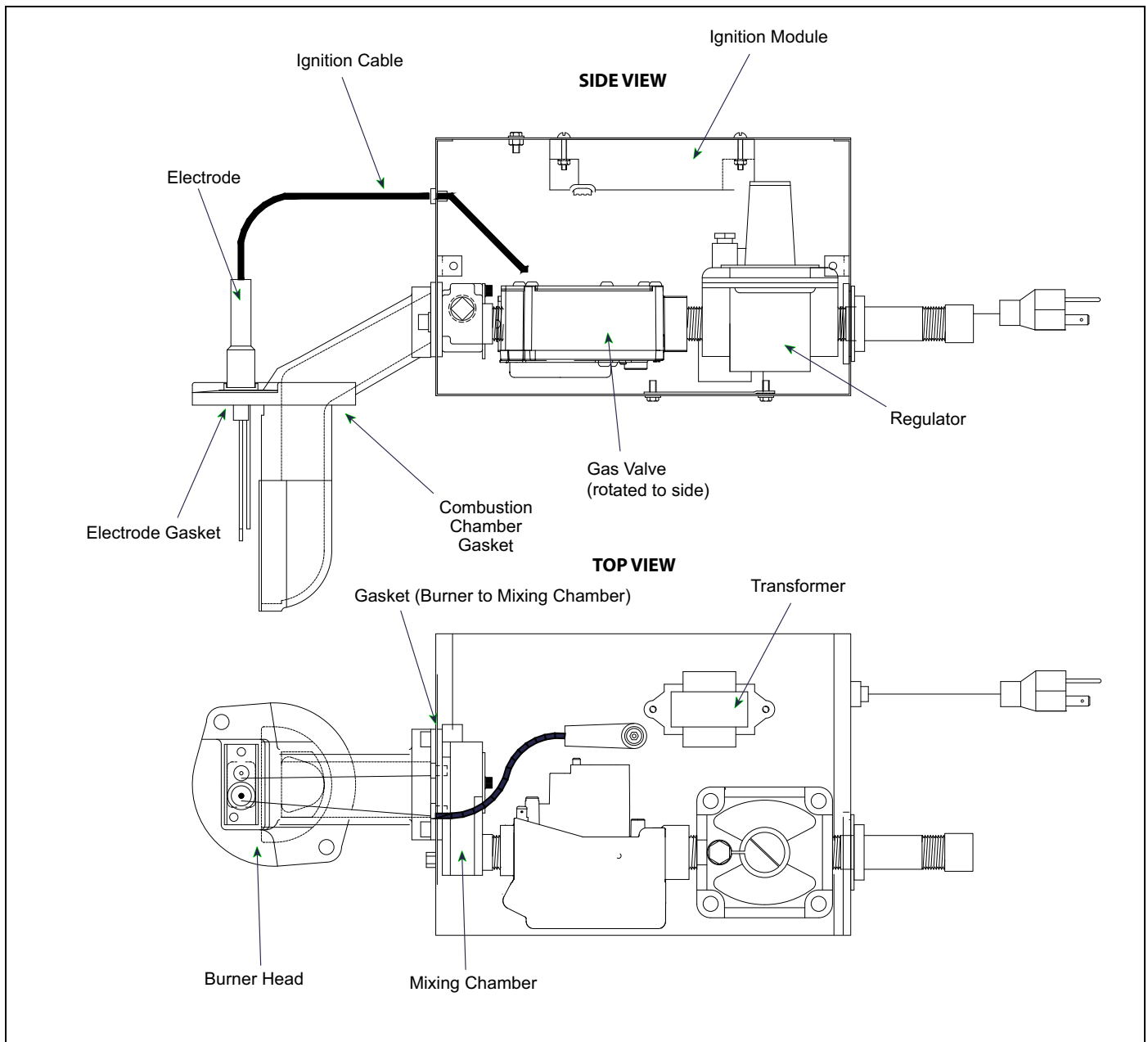

Description	Part Number
Gas Valve LP or NG (White-Rodgers Gas Valve - For burners made after 1/1/2018)	90032512
Gasket (Burner to Mixing Chamber)	01351100
Burner Head Assembly Replacement Package (includes electrode and gasket installed)	02713000
Mixing Chamber	02790400
Transformer	90436900K
Regulator Replacement Kit	02725300
Gasket (Combustion Chamber)	01367800
Electrode Replacement Kit (includes electrode, electrode gasket and mounting screws)	02713200
Ignition Module	90439500K
Ignition Cable	90427706
Filter Cartridge with Gasket (not shown)	01312401

19.1 Replacement Parts Instructions

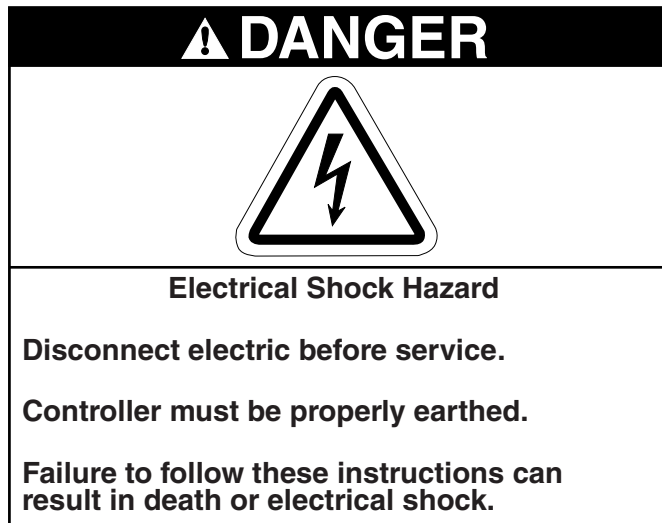

power to the VFD assembly and verify that the VFD LCD screen is on. (dashes displayed). Close the VFD assembly door.

19.1.1 Variable Frequency Drive (VFD)

To replace the Variable Frequency Drive, turn off all power to the drive assembly at the breaker or disconnect switch.

Mark all wires connected to the VFD, noting the terminals that they are secured to. Remove all wires from the VFD terminals.

Remove the VFD from its mounting plate by removing the securing screws.

Verify that the input voltage noted on the rating plate of the VFD matches the input voltage of the old VFD. Secure the new VFD to the mounting plate with the screws. Return all wires to the correct VFD terminals. If possible, it may be easier to partially re-wire the new VFD before mounting it to the mounting plate.

Turn on power to VFD.

Using procedure described on *Page 68, Section 14.1.1 through Page 68, Section 14.1.5*, alter parameter according to VFD model and make as shown on *Page 69 or 69*.

19.1.2 Variable Frequency Drive 25 A or 10 A Fuse-VFD For Modulating Thermostat Only

To replace a fuse, turn off input power to the variable frequency drive assembly at the breaker or disconnect switch.

Inside the VFD assembly, open the fuse holder by pulling down the lever to expose the fuse. Remove the old fuse and insert a new fuse. Verify the correct fuse rating, 25 A for 1 HP 120 V VFD or 2 HP 230 V VFD, 10 A for the .75 HP 230 V VFD, 1 HP 460 V VFD and 2 HP 460 V VFD. Close the fuse holder. Return

SECTION 20: GENERAL SPECIFICATIONS**20.1 Material Specifications****20.1.1 Reflectors**

.024 Aluminium (Optional- 024 Stainless Steel Type 304, Standard Reflectors Only).

20.2 Heater Specifications**20.2.1 Ignition**

Fully Automatic, Three-Try, Direct Spark, Electronic Ignition Control, 100% Safety Shut-Off.

General Specifications for CRV-Series heaters are as follows:

20.3 Suspension Specifications

Hang heater with materials with a minimum working load of 75 lbs (33 kg). See Page 21, Figure 20.

20.4 Controls Specifications

Time switches, thermostats, etc. can be wired into the electrical supply. External controls supplied as an option.

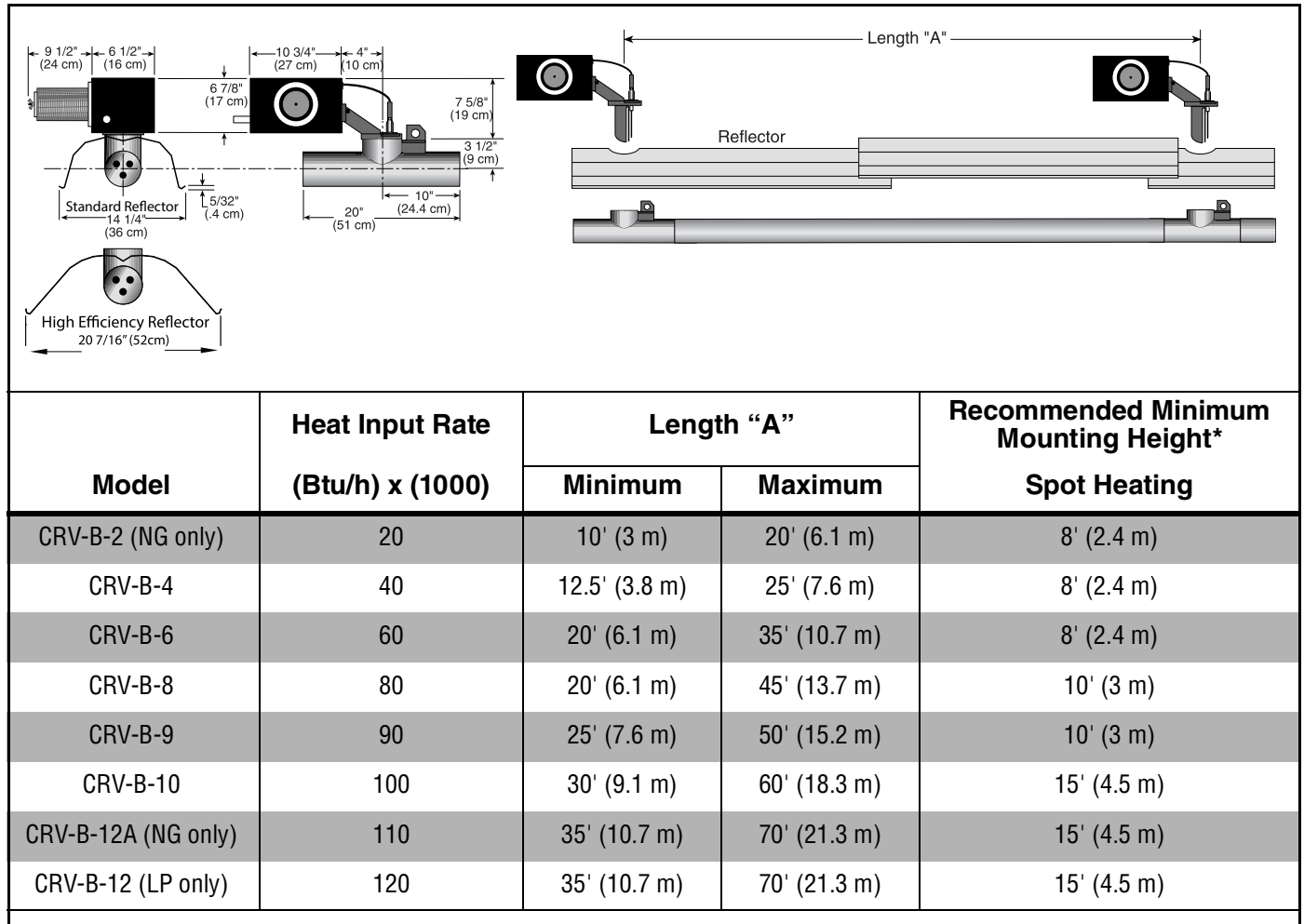

*See Page 5, Section 3 for clearances to combustibles.

PIPE CONNECTION:

1/2" NPT

DIMENSIONS:

Vent Connection Size: 4" (10 cm) or 6" (15 cm)
Outside Air Connection Size: 4" (10 cm)
Refer to figure above for dimensional information.

GAS INLET PRESSURE:

Natural Gas: 4.5" wc Minimum 14.0" wc Maximum

LP Gas: 10.5" wc Minimum 14.0" wc Maximum

ELECTRICAL RATING:

120 V - 60 Hz, 0.3 A

PRODUCT "TYPE" ACCORDING TO ASHRAE HANDBOOK-HVAC SYSTEMS AND EQUIPMENT (LATEST EDITION)

Type: "B" - Indirect Tube-Type Heater (Vacuum Operated)

General Specifications for pumps are as follows:

Pump Dimensional Data (in.)

Model	A	B	C	D	E	F	G
EP-100	17	14.5	21	3.75	10	4	4
EP-201/203	17.75	17	20.25	3.25	10	4.5	4.5
EP-301/303	25.6	24.8	22.7	4.8	15.2	6	6

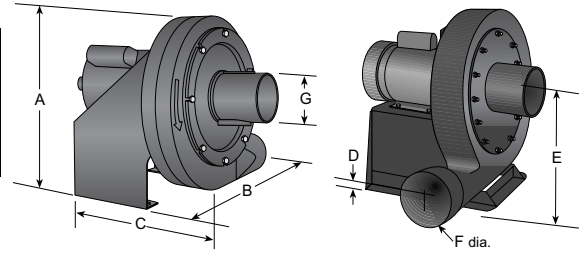

Pump Specifications

Model	EP-100	EP-201	EP-203	EP-301	EP-303
Horsepower (Hp)	1/3	3/4	3/4	2*	2*
Phase (Ø)	1	1	3	1	3
Hertz (Hz)	60	60	60	60	60
Voltage (V)	115/230	115/230	208-230/460	208-230	208-230/460
Full Load Amp (Amps)	4.8/2.4	6.6/3.3	2.4-2.2/1.1	12.8-11.5	5.5-5.2/2.6
R.P.M.	3450	3450	3500	3450	3450
Motor Frame	56	56	56	90	90
Motor Enclosure	TEFC	TEFC	TEFC	TEFC	TEFC
Noise Level @ 5' (DBA)	-	70	70	-	-
Inlet/Outlet (In.)	4/4	4.5/4.5	4.5/4.5	6/6	6/6
Weight (lbs.)	62	112	112	170	170

* For starter, see National Electric Code (NEC) requirement for motors 1 hp or higher.

Air Supply Blower Specifications

Capacity	240 CFM @ 0.75 in wc
Power (W)	167
Phase	1
Hertz (Hz)	60
Voltage (V)	120
Full Load Amp (Amps)	1.5
R.P.M.	3000
Motor Enclosure	OPEN FC
Inlet/Outlet (In.)	5/5
Weight (lbs.)	10

SECTION 21: THE ROBERTS GORDON® CORAYVAC® LIMITED WARRANTY**ROBERTS-GORDON LLC WILL PAY FOR:**

Within 36 months from date of purchase by buyer or 42 months from date of shipment by Roberts-Gordon LLC (whichever occurs first), replacement parts will be provided free of charge for any part of the product which fails due to a manufacturing or material defect.

Roberts-Gordon LLC will require the part in question to be returned to the factory. Roberts-Gordon LLC will, at its sole discretion, repair or replace after determining the nature of the defect and disposition of part in question.

ROBERTS GORDON® warrants the cast iron combustion chamber of the ROBERTS GORDON® CORAYVAC® Classic System will be free from defects in material and workmanship. This warranty is limited to twenty-five (25) years from the date of shipment by Roberts-Gordon LLC. All other components of the ROBERTS GORDON® CORAYVAC® Classic System adhere to the standard warranty listed in the paragraph above.

ROBERTS GORDON® Replacement Parts are warranted for a period of 12 months from date of shipment from Roberts-Gordon LLC or the remaining ROBERTS GORDON® CORAYVAC® warranty.

ROBERTS-GORDON LLC WILL NOT PAY FOR:

Service trips, service calls and labor charges.

Shipment of replacement parts.

Claims where the total price of the goods have not been paid.

Damage due to:

- Improper installation, operation or maintenance.
- Misuse, abuse, neglect, or modification of the ROBERTS GORDON® CORAYVAC® in any way.
- Use of the ROBERTS GORDON® CORAYVAC® for other than its intended purpose.
- Incorrect gas or electrical supply, accident, fire, floods, acts of God, war, terrorism, or other casualty.
- Improper service, use of replacement parts or accessories not specified by Roberts-Gordon.
- Failure to install or maintain the ROBERTS GORDON® CORAYVAC® as directed in the Installation, Operation and Service Manual.
- Relocation of the ROBERTS GORDON® CORAYVAC® after initial installation
- The use of the ROBERTS GORDON® CORAYVAC® in a corrosive atmosphere containing contaminants.
- The use of the ROBERTS GORDON® CORAYVAC® in the vicinity of a combustible or explosive material.
- Any defect in the ROBERTS GORDON® CORAYVAC® arising from a drawing, design, or specification supplied by or on behalf of the consumer.
- Damage incurred during shipment. Claim must be filed with carrier.

WARRANTY IS VOID IF:

The ROBERTS GORDON® CORAYVAC® is not installed by a contractor qualified in the installation and service of gas fired heating equipment.

You cannot prove original purchase date and required annual maintenance history.

The data plate and/or serial number are removed, defaced, modified or altered in any way.

The ownership of the ROBERTS GORDON® CORAYVAC® is moved or transferred. This warranty is nontransferable.

Roberts-Gordon LLC is not permitted to inspect the damaged equipment and/or component parts.

READ YOUR INSTALLATION, OPERATION AND SERVICE MANUAL

If you have questions about your equipment, contact your installing professional. Should you need Replacement Parts or have additional questions, call or write:

Roberts-Gordon LLC

1250 William Street

P.O. Box 44

Buffalo, New York 14240-0044

Telephone: +1.716.852.4400

Fax: +1.716.852.0854 Toll Free: 800.828.7450

www.robertsgordon.com

Roberts-Gordon LLC's liability, and your exclusive remedy, under this warranty or any implied warranty (including the implied warranties of merchantability and fitness for a particular purpose) is limited to providing replacement parts during the term of this warranty. Some jurisdictions do not allow limitations on how long an implied warranty lasts, so this limitation may not apply to you. There are no rights, warranties or conditions, expressed or implied, statutory or otherwise, other than those contained in this warranty.

Roberts-Gordon LLC shall in no event be responsible for incidental or consequential damages or incur liability for damages in excess of the amount paid by you for the ROBERTS GORDON® CORAYVAC®. Some jurisdictions do not allow the exclusion or limitation of incidental or consequential damages, so this limitation or exclusion may not apply to you. This warranty gives you specific legal rights, and you may also have other rights which vary from jurisdiction to jurisdiction.

Roberts-Gordon LLC shall not be responsible for failure to perform under the terms of this warranty if caused by circumstances out of its control, including but not limited to war, fire, flood, strike, government or court orders, acts of God, terrorism, unavailability of supplies, parts or power. No person is authorized to assume for Roberts-Gordon LLC any other warranty, obligation or liability.

LIMITATIONS ON AUTHORITY OF REPRESENTATIVES:

No representative of Roberts-Gordon LLC, other than an Executive Officer, has authority to change or extend these provisions. Changes or extensions shall be binding only if confirmed in writing by Roberts-Gordon LLC's duly authorized Executive Officer.

OWNER WARRANTY REGISTRATION CARD

Mail or Fax to:
Roberts Gordon LLC • 1250 William Street, P.O. Box 44 • Buffalo, NY 14240-0044 • Phone: 716-852-4400 • Fax: 716-852-0854
www.robertsgordon.com

About the Owner:

Name: _____
Address: _____ City: _____ State: _____ Zip Code: _____
Phone: _____ Fax: _____ E-mail: _____

About the Installer:

Name: _____
Address: _____ City: _____ State: _____ Zip Code: _____
Phone: _____ Fax: _____ E-mail: _____

Purchased From (if different than installer):

Name: _____
Address: _____ City: _____ State: _____ Zip Code: _____
Phone: _____ Fax: _____ E-mail: _____

About your Heater:

Model #: _____ Serial #: _____ Fuel: _____ Installation Date: _____

Type of Installation (check one):

- Automotive Manufacturing Warehouse Recreational Aircraft
 Public Building Office Retail Agricultural Other _____
-

Installation Code and Annual Inspections: All installation and service of ROBERTS GORDON® equipment must be performed by a contractor qualified in the installation and service of equipment sold and supplied by Roberts-Gordon LLC and conform to all requirements set forth in the ROBERTS GORDON® manuals and all applicable governmental authorities pertaining to the installation, service, operation and labeling of the equipment.

To help facilitate optimum performance and safety, Roberts-Gordon LLC recommends that a qualified contractor conduct, at a minimum, annual inspections of your ROBERTS GORDON® equipment and perform service where necessary, using only replacement parts sold and supplied by Roberts-Gordon LLC.

These products are not for residential use.

This product is intended to assist licensed professionals in the exercise of their professional judgment.

Attach this information to a wall near the ROBERTS GORDON® heater.

ROBERTS GORDON®

Infrared Heating

Read the Installation, Operation, and Service Manual thoroughly before installation, operation, or service.

Know your model number and installed configuration.

Model number and installed configuration are found on the burner and in the Installation, Operation and Service Manual.

Write the largest clearance dimensions with permanent ink according to your model number and configuration in the open spaces below.

OPERATING INSTRUCTIONS

1. STOP! Read all safety instructions on this information sheet.
2. Open the manual gas valve in the heater supply line.
3. Turn on electric power to the heater.
4. Set the thermostat to desired setting.

TO TURN OFF THE HEATER

1. Set the thermostat to off or the lowest setting.

IF THE HEATER WILL NOT OPERATE, TO ENSURE YOUR SAFETY, FOLLOW THESE INSTRUCTIONS TO SHUT DOWN YOUR HEATER

1. Set the thermostat to off or the lowest setting.
2. Turn off electric power to the heater.
3. Turn off the manual gas valve in the heater supply line.
4. Call your registered installer/contractor qualified in the installation and service of gas-fired heating equipment.

⚠ WARNING



Fire Hazard

Keep all flammable objects, liquids and vapors the minimum required clearances to combustibles away from heater.

Some objects will catch fire or explode when placed close to heater.

Failure to follow these instructions can result in death, injury or property damage.

**Maintain _____ clearance
to the side and
_____ clearance below
the heater from vehicles
and combustible materials.**

Roberts-Gordon LLC
1250 William Street
P.O. Box 44
Buffalo, NY 14240-0044 USA
Telephone: +1.716.852.4400
Fax: +1.716.852.0854

Installation Code and Annual Inspections:

All installation and service of ROBERTS GORDON® equipment must be performed by a contractor qualified in the installation and service of equipment sold and supplied by Roberts-Gordon and conform to all requirements set forth in the ROBERTS GORDON® manuals and all applicable governmental authorities pertaining to the installation, service, operation and labeling of the equipment. To help facilitate optimum performance and safety, Roberts-Gordon recommends that a qualified contractor conduct, at a minimum, annual inspections of your ROBERTS GORDON® equipment and perform service where necessary, using only replacement parts sold and supplied by Roberts-Gordon.

Further Information: Applications, engineering and detailed guidance on systems design, installation and equipment performance is available through ROBERTS GORDON® representatives. Please contact us for any further information you may require, including the Installation, Operation and Service Manual.

This product is not for residential use.

© 2017 Roberts-Gordon LLC

All rights reserved. No part of this work covered by the copyrights herein may be reproduced or copied in any form or by any means – graphic, electronic, or mechanical, including photocopying, recording, taping, or information storage and retrieval systems – without written permission of Roberts-Gordon LLC.

www.robertsgordon.com

P/N 91037912 Rev. K

