

Combat[®] IDF-Series

Indirect, Gas/Oil-Fired, Industrial Air Handler

Installation, Operation & Service Manual

IDF 35	IDF 175
IDF 45	IDF 200
IDF 50	IDF 225
IDF 65	IDF 250
IDF 75	IDF 275
IDF 85	IDF 300
IDF 100	IDF 350
IDF 125	IDF 400
IDF 150	IDF 450

FOR YOUR SAFETY

If you smell gas:

1. Open windows.
2. **DO NOT** try to light any appliance.
3. **DO NOT** use electrical switches.
4. **DO NOT** use any telephone in your building.
5. Extinguish any open flame.
6. Leave the building.
7. Immediately call your local fuel supplier after leaving the building. Follow the fuel supplier's instructions.
8. If you cannot reach your fuel supplier, call the Fire Department.

WARNING



Fire Hazard

Keep all flammable objects, liquids and vapors the minimum required clearances to combustibles away from equipment.

Some objects will catch fire or explode when placed close to equipment.

Failure to follow these instructions can result in death, injury or property damage.

WARNING

Improper installation, adjustment, alteration, service or maintenance can result in death, injury or property damage. Read the installation, operation and service manual thoroughly before installing or servicing this equipment.

Installation must be done by a registered installer/contractor qualified in the installation and service of gas/oil-fired heating equipment or your fuel supplier.

NOT FOR RESIDENTIAL USE



Installer

Please take the time to read and understand these instructions prior to any installation. Installer must give a copy of this manual to the owner.

Owner

Keep this manual in a safe place in order to provide your serviceman with necessary information.

Roberts-Gordon LLC

1250 William Street
P.O. Box 44
Buffalo, New York 14240-0044
Telephone: +1.716.852.4400
Fax: +1.716.852.0854
Toll Free: 800.828.7450

www.robertsgordon.com
www.rg-inc.com

Combat® IDF-Series

L'appareil de traitement de l'air à combustion indirecte, au gaz ou à l'huile pour les applications industrielles

Manuel d'installation, d'opération, et d'entretien

IDF 35	IDF 175
IDF 45	IDF 200
IDF 50	IDF 225
IDF 65	IDF 250
IDF 75	IDF 275
IDF 85	IDF 300
IDF 100	IDF 350
IDF 125	IDF 400
IDF 150	IDF 450

POUR VOTRE SECURITE
Si vous sentez une odeur de gaz:

1. Ouvrez les fenêtres.
2. N'essayez PAS d'allumer un appareil.
3. N'utilisez PAS d'interrupteurs électriques.
4. N'utilisez PAS de téléphone dans votre bâtiment.
5. Eteignez toute flamme nue.
6. Quittez le bâtiment.
7. Après avoir quitté le bâtiment, appelez immédiatement votre fournisseur local de gaz. Suivez les instructions du fournisseur de gaz.
8. Si vous ne pouvez pas joindre votre fournisseur de gaz, appelez le service d'incendie.

⚠ AVERTISSEMENT



Risque d'incendie

Garder tous les objets, liquides ou vapeurs inflammables à la distance minimale de l'unité de chauffage requise avec les matériaux combustibles.

Certains objets prendront feu ou exploseront s'ils sont placés à proximité de l'unité de chauffage.

Le non respect de ces instructions peut entraîner la mort, des blessures corporelles ou des dommages matériels.

⚠ ATTENTION

L'installation, l'ajustement, l'altération, le démarrage ou l'entretien inadéquat peuvent causer la mort, des blessures ou des dégâts matériels. Lire entièrement le manuel d'installation, d'opération et d'entretien avant l'installation ou l'entretien de cet équipement.

L'installation doit être effectuée par un installateur éprouvé/contractant qualifié dans l'installation et la maintenance du système de chauffage par infrarouge activé au gaz.

Installateur

Prenez le temps de lire et comprendre ces instructions avant toute installation.

L'installateur doit remettre au propriétaire un exemplaire de ce manuel.

Propriétaire

Gardez ce manuel dans un endroit sûr pour fournir des informations au réparateur en cas de besoin.

Conçus pour les applications non-résidentielles



Roberts-Gordon LLC
1250 William Street
P.O. Box 44
Buffalo, New York 14240-0044
Téléphone: +1.716.852.4400
Fax: +1.716.852.0854
Numéro sans frais: 800.828.7450

www.robertsgordon.com
www.rg-inc.com

TABLE OF CONTENTS

SECTION 1: Air Handler Safety	1	SECTION 14: Service Platform	60
1.1 Description of Operation.....	1	SECTION 15: Dampers	63
1.2 Inspection and Setup	1	15.1 Discharge Damper Installation.....	63
1.3 Safety Labels and Their Placement	1	15.2 Inlet Damper Installation.....	64
1.4 California Proposition 65	2	SECTION 16: Discharge Heads and Discharge Louvers ...	66
1.5 Label Placement	2	16.1 Discharge Heads' Installation	66
SECTION 2: Installer Responsibility	11	16.2 Discharge Louvers' Installation	67
2.1 Corrosive Chemicals.....	12	SECTION 17: Duct Considerations	69
2.2 Required Equipment and Materials.....	12	17.1 Inlet Duct Work.....	69
SECTION 3: Critical Considerations	13	17.2 Return Air Duct.....	69
3.1 Required Clearances to Combustibles.....	13	17.3 Discharge Duct Work	69
3.2 Hardware	13	SECTION 18: Venting	70
SECTION 4: National Standards and Applicable Codes ...	14	18.1 General Venting Requirements.....	70
4.1 Fuel Codes.....	14	18.2 Recommended Flue Venting Practices	70
4.2 Installation Codes	14	18.3 Heat Exchanger Condensate Drain Connection	71
4.3 Aircraft Hangars	14	SECTION 19: Burners	72
4.4 Parking Structures and Repair Garages	15	19.1 Principle of Operation	72
4.5 Electrical	15	19.2 Burner Pilot Assemblies	73
4.6 Venting.....	15	19.3 Combustion Air Intake Collar	73
4.7 High Altitude	15	SECTION 20: Gas Piping For Gas-Fired Air Handlers	77
SECTION 5: Specifications	16	20.1 Gas Manifolds.....	77
SECTION 6: Lifting an Air Handler	25	20.2 Gas Piping and Pressures	77
6.1 Lifting an Air Handler	25	20.3 Gas Manifold Venting	83
SECTION 7: Air Handler Assembly	27	20.4 Gas Piping.....	83
SECTION 8: Vibration Isolators	30	20.5 Pressure Test Ports	83
8.1 Waffle Pad Isolator	30	20.6 Line Pressure Test - Leak Testing.....	84
8.2 Neoprene or Spring Isolators for Hanger-Mounted Units	31	SECTION 21: Oil Piping For Oil-Fired Air Handlers	85
8.3 Neoprene or Spring Isolators for Pad-Mounted Units.....	35	21.1 Oil Piping and Pressures.....	85
8.4 Spring Mount Isolator.....	38	21.2 Line Pressure Test - Leak Testing	86
SECTION 9: Roof Curb	41	21.3 Pressure Test Ports	86
9.1 Roof Curb Assembly and Installation.....	41	21.4 Oil Manifolds	86
9.2 Air Handler Mounting to Roof Curb.....	43	SECTION 22: Combination Gas And Oil Burners	89
SECTION 10: Upright Stand	45	22.1 Switching Between Fuels	90
10.1 Upright Stand Installation.....	45	22.2 Semi-Automatic Change Over	90
10.2 Attaching Air Handler to Stand.....	45	22.3 Fully-Automatic Change Over.....	91
SECTION 11: Filter Section	48	SECTION 23: Electrical	92
11.1 Filter Section Installation - Horizontal Air Handlers (Models 35 - 450)	49	23.1 Wiring and Electrical Connections.....	92
11.2 Filter Section Installation - Upright Air Handlers (Models 35 - 450).....	50	23.2 Remote Panel.....	92
SECTION 12: Mixing Box	51	23.3 Motor Current Draw	92
12.1 Mixing Box Section Installation - Horizontal Air Handlers (Models 35 - 450)	51	23.4 Control Current Draw.....	92
12.2 Mixing Box Section Installation - Upright Air Handlers (Models 35 - 450)	53	23.5 Safety Systems.....	92
SECTION 13: Inlet Hoods	54	SECTION 24: Sequence of Operation	122
13.1 Inlet Hood Installation (Models 35 - 125)	55	24.1 Air Handler Configuration	122
13.2 Inlet Hood Installation (Models 150 - 450)	56	24.2 Remote Panel Options.....	123
		24.3 Basic Sequence of Operation.....	124
		24.4 Night Setback Options.....	128
		24.5 Other Control Options.....	128
		SECTION 25: Start-up Procedures	130
		25.1 Mechanical	131
		25.2 Electrical	132
		25.3 Airflow.....	132

© 2012 Roberts-Gordon LLC

All rights reserved. No part of this work covered by the copyrights herein may be reproduced or copied in any form or by any means - graphic, electronic, or mechanical, including photocopying, recording, taping or information storage and retrieval systems - without the written permission of Roberts-Gordon LLC.

25.4 General Start-up Procedures (All Fuels)	132
25.5 Blower Start-Up	132
25.6 Burner Start-Up.....	132
25.7 Gas Pressure Adjustments.....	133
25.8 Oil Pressure Adjustments.....	134
25.9 Gas Fired Equipment Start-Up Procedures.....	136
25.10 Oil Fired Equipment Start-Up Procedures.....	137
25.11 Accessories and Controls Start-Up	138
SECTION 26: Maintenance	139
26.1 General	140
26.2 Unit Exterior	140
26.3 Blower Section	140
26.4 Manifold and Controls	142
26.5 Burner	142
26.6 Dampers	142
26.7 Filters	142
26.8 Motor and Drive Components	142
SECTION 27: Replacement Parts.....	143
27.1 Replacement Blower Components	143
27.2 Replacement V-Belts	147
27.3 Replacement Damper Components	149
27.4 Replacement Burner Components	149
27.5 Replacement Manifold Components.....	150
27.6 Replacement Electrical Components.....	151
27.7 Replacement Filters.....	152
27.8 Miscellaneous Replacement Parts	152
SECTION 28: Troubleshooting	154
28.1 Initial Checks.....	155
28.2 Supply Fan.....	156
28.3 Burner	157
28.4 Gas Operation	158
28.5 Oil Operation.....	159
28.6 Burner Control Module.....	162
28.7 ROBERTS GORDON® IDF Start-Up Procedures...	166
SECTION 29: The ROBERTS GORDON® IDF-Series	
Warranty	171

TABLE OF FIGURES

Figure 1: Indoor Upright (Models 35 - 100)	2
Figure 2: Indoor Upright (Models 125 - 450)	3
Figure 3: Indoor Horizontal (Models 35 -100)	4
Figure 4: Indoor Horizontal (Models 125 - 450).....	5
Figure 5: Outdoor Upright (Models 35 - 100)	6
Figure 6: Outdoor Upright (Models 125 - 400)	7
Figure 7: Outdoor Horizontal (Models 35 - 100).....	8
Figure 8: Outdoor Horizontal (Models 125 - 400).....	9
Figure 9: Control Enclosure Door (Inside).....	10
Figure 10: 8.1 Remote Panel.....	10
Figure 11: 8.5 Remote Panel.....	10
Figure 12: Upright Model Dimensions (Models 35 - 125).....	16
Figure 13: Horizontal Model Dimensions (Models 35 - 125) ...	17
Figure 14: Upright Model Dimensions (Models 150 - 450).....	18
Figure 15: Horizontal Model Dimensions (Models 150 - 450).....	19
Figure 16: Percentage of Airflow Capacity.....	21
Figure 17: Internal Static Pressure	21
Figure 18: Lifting a Horizontal Air Handler.....	26
Figure 19: Lifting an Upright Air Handler	26
Figure 20: Air Handler Assembly - Horizontal (Models 150 - 450).....	28
Figure 21: Air Handler Assembly - Upright (Models 150 - 450).....	29
Figure 22: Waffle Pad Isolator	30
Figure 23: Pad Isolator Installation Instructions	31
Figure 24: Hanging Isolators.....	32
Figure 25: Hanger Isolators' Installation Instructions	32
Figure 26: Hanging Rods' Installation Instructions (Models 35 - 125).....	33
Figure 27: Hanging Rods' Installation Instructions (Models 150 - 450).....	34
Figure 28: Pad Mounting of Neoprene Isolator.....	35
Figure 29: Pad Mounting Instructions for Neoprene Isolator (Models 35 - 125).....	36
Figure 30: Pad Mounting Instructions for Neoprene Isolator (Models 150 - 450).....	37
Figure 31: Pad Mounting of Spring Isolator	38
Figure 32: Pad Mounting Instructions for Spring Isolator (Models 35 - 125).....	39
Figure 33: Pad Mounting Instructions for Spring Isolator (Models 150 - 450).....	40
Figure 34: Roof Curb.....	42
Figure 35: Curb Mounting (Models 35 -125)	43
Figure 36: Curb Mounting (Models 150 - 450)	44
Figure 37: Upright Stand Detail (Models 35 - 100).....	46
Figure 38: Upright Stand Detail (Models 125 - 450).....	46
Figure 39: Stand Mounting Detail (Models 125 - 450)	47
Figure 40: Filter Section Installation on Horizontal Air Handler	49
Figure 41: Filter Section Installation on Upright Air Handler ...	50
Figure 42: Mixing Box Section Installation on Horizontal Air Handler.....	52
Figure 43: Mixing Box Section Installation on Upright Air Handler	53
Figure 44: Inlet Hood Installation to Air Handler (Models 35 - 125).....	55
Figure 45: Horizontal Service Platform (Models 35 - 450)	61
Figure 46: Upright Service Platform (Models 35 - 450).....	62
Figure 47: Discharge Damper Installation for Horizontal Air Handler with Bottom Discharge	64
Figure 48: Inlet Damper	65
Figure 49: Discharge Heads	67
Figure 50: Double Deflection Discharge Louvers.....	68
Figure 51: Condensate Drain	71
Figure 52: Typical "Type J" Burner.....	72
Figure 53: Typical "Type C" Burner	73
Figure 54: "Type J" Burner with Flame Rod - Natural Gas Only (Not for use with LPG).....	73
Figure 55: "Type J" Burner with Ultraviolet Scanner - Natural Gas or LPG	74
Figure 56: "Type C" Burner with Ignition Electrode - Natural Gas or LPG	75
Figure 57: "Type C" Burner with Ignition Electrode - Oil	76
Figure 58: Manifold Diagram for Gas-Fired Air Handler with any FM-Compliant Manifold/XL-Compliant Manifold Rated for Less Than 1,000 MBH (293 kW) and with On/Off or High/Low/Off Burners	79
Figure 59: Manifold Diagram for Gas-Fired Air Handler with any FM-Compliant Manifold/XL-Compliant Manifold Rated for Less Than 1,000 MBH (293 kW) and with Modulating Burner	80
Figure 60: Manifold Diagram for Gas-Fired Air Handler with XL- Compliant Manifold Rated for More Than 1,000 MBH (293 kW) and with On/Off or High/Low/Off Burner	81
Figure 61: Manifold Diagram for Gas-Fired Air Handler with XL- Compliant Manifold Rated for More Than 1,000 MBH (293 kW) and with Modulating Burner	82
Figure 62: Test Port Location	83
Figure 63: Location of Side Orifice.....	84
Figure 64: Two-Pipe Oil System.....	85
Figure 65: Suntec Two Step Pump.....	86
Figure 66: Webster 3450 RPM Blower Motor Driven Oil Pump.....	86
Figure 67: FM or XL-Compliant Manifold for Air Handlers with Suntec Pump and On/Off Burner	86
Figure 68: FM or XL-Compliant Manifold for Air Handlers with Suntec Pump and High/Low/Off Burner.....	87
Figure 69: FM or XL-Compliant Manifold for Air Handlers with Webster Pump and High/Low/Off Burner.....	87
Figure 70: FM or XL-Compliant Manifold for Air Handlers with Webster Pump and Fully-Modulating Burner.....	88
Figure 71: Typical Linkage for a Combination Gas/Oil Burner	89
Figure 72: Burner Oil Pump Shaft Coupling Location	90
Figure 73: Remote Oil Pump	91
Figure 74: Wiring Diagram Key	95
Figure 75: Wiring Diagram for Gas-Fired Air Handler with FM- Compliant Manifold and On/Off Burner with Input Less Than 2,500 MBH (732.7 kW).....	96
Figure 76: Wiring Diagram for Gas-Fired Air Handler with FM- Compliant Manifold and High/Low/Off Burner with Input Less Than 2,500 MBH (732.7 kW)	97
Figure 77: Wiring Diagram for Gas-Fired Air Handler with FM- Compliant Manifold and High/Low/Off Burner with Input 2,500 to 5,000 MBH (732.7 - 1465.4 kW)	98
Figure 78: Wiring Diagram for Gas-Fired Air Handler with FM- Compliant Manifold and High/Low/Off Burner with Input More Than 5,000 MBH (1465.4 kW).....	99
Figure 79: Wiring Diagram for Gas-Fired Air Handler with FM- Compliant Manifold and Fully-	

Modulating Burner with Input Less Than 2,500 MBH (732.7 kW)	100	Figure 97: Wiring Diagram for Oil-Fired Air Handler with XL-Compliant Manifold and High/Low/Off Burner with Input Less Than 1,000 MBH (293.1 kW)	118
Figure 80: Wiring Diagram for Gas-Fired Air Handler with FM-Compliant Manifold and Fully-Modulating Burner with Input 2,500 to 5,000 MBH (732.7 - 1465.4 kW)	101	Figure 98: Wiring Diagram for Oil-Fired Air Handler with XL-Compliant Manifold and High/Low/Off Burner with Input More Than 1,000 MBH (293.1 kW)	119
Figure 81: Wiring Diagram for Gas-Fired Air Handler with FM-Compliant Manifold and Fully-Modulating Burner with Input More Than 5,000 MBH (1465.4 kW)	102	Figure 99: Wiring Diagram for Oil-Fired Air Handler with XL-Compliant Manifold and Fully-Modulating Burner with Input Less Than 1,000 MBH (293.1 kW)	120
Figure 82: Wiring Diagram for Gas-Fired Air Handler with XL-Compliant Manifold and On/Off Burner with Input Less Than 1,000 MBH (293.1 kW)	103	Figure 100: Wiring Diagram for Oil-Fired Air Handler with XL-Compliant Manifold and Fully-Modulating Burner with Input More Than 1,000 MBH (293.1 kW)	121
Figure 83: Wiring Diagram for Gas-Fired Air Handler with XL-Compliant Manifold and On/Off Burner with Input 1,000 to 2,500 MBH (293.1 - 732.7 kW)	104	Figure 101: Air Handler Configurations	123
Figure 84: Wiring Diagram for Gas-Fired Air Handler with XL-Compliant Manifold and High/Low/Off Burner with Input Less Than 1,000 MBH (293.1 kW)	105	Figure 102: Wiring Subbase and Sequence Chart for RM7897 Burner Control Module.....	126
Figure 85: Wiring Diagram for Gas-Fired Air Handler with XL-Compliant Manifold and High/Low/Off Burner with Input 1,000 to 5,000 MBH (293.1 - 1465.4 kW) ...	106	Figure 103: Wiring Subbase and Sequence Chart for RM7800 Burner Control Module.....	127
Figure 86: Wiring Diagram for Gas-Fired Air Handler with XL-Compliant Manifold and High/Low/Off Burner with Input More Than 5,000 MBH (1465.4 kW)	107	Figure 104: Sheave Alignment	131
Figure 87: Wiring Diagram for Gas-Fired Air Handler with XL-Compliant Manifold and Fully-Modulating Burner with Input Less Than 1,000 MBH (293.1 kW)	108	Figure 105: Belt Tension.....	132
Figure 88: Wiring Diagram for Gas-Fired Air Handler with XL-Compliant Manifold and Fully-Modulating Burner with Input 1,000 to 5,000 MBH (293.1 - 1465.4 kW)	109	Figure 106: Low Fire Adjustment for High/Low/Off Burner ...	133
Figure 89: Wiring Diagram for Gas-Fired Air Handler with XL-Compliant Manifold and Fully-Modulating Burner with Input More Than 5,000 MBH (1465.4 kW)	110	Figure 107: Low Fire Adjustment for Fully-Modulating Burner with Linkage Adjustment.....	134
Figure 90: Wiring Diagram for Oil-Fired Air Handler with FM-Compliant Manifold and On/Off Burner with Input Less Than 2,500 MBH (732.7 kW)	111	Figure 108: Low Fire Adjustment for Fully-Modulating Burner with Stop Screw Adjustment.....	134
Figure 91: Wiring Diagram for Oil-Fired Air Handler with FM-Compliant Manifold and High/Low/Off Burner with Input Less Than 2,500 MBH (732.7 kW).....	112	Figure 109: Oil Pressure Adjustments for On/Off Burner	134
Figure 92: Wiring Diagram for Oil-Fired Air Handler with FM-Compliant Manifold and High/Low/Off Burner with Input More Than 2,500 MBH (732.7 kW)	113	Figure 110: Oil Pressure Adjustment High/Low/Off Burner with Suntec Pump	135
Figure 93: Wiring Diagram for Oil-Fired Air Handler with FM-Compliant Manifold and Fully-Modulating Burner with Input Less Than 2,500 MBH (732.7 kW)	114	Figure 111: Oil Pressure Adjustments for High/Low/Off Burner with Webster Pump	135
Figure 94: Wiring Diagram for Oil-Fired Air Handler with FM-Compliant Manifold and Fully-Modulating Burner with Input More Than 2,500 MBH (732.7 kW)	115	Figure 112: Oil Pressure Adjustments for Fully-Modulating Burner with Webster Pump.....	136
Figure 95: Wiring Diagram for Oil-Fired Air Handler with XL-Compliant Manifold and On/Off Burner with Input Less Than 1,000 MBH (293.1 kW)	116		
Figure 96: Wiring Diagram for Oil-Fired Air Handler with XL-Compliant Manifold and On/Off Burner with Input Less Than 2,500 MBH (732.7 kW)	117		

LIST OF TABLES

Table 1: Recommended Torque Settings.....	13
Table 2: Legend	16
Table 3: Cabinet Dimensions (Models 35 - 125)	16
Table 4: Estimated Shipping Weights (Models 35 - 125)	17
Table 5: Estimated Shipping Weights - Burners (Models 35 - 125).....	17
Table 6: Estimated Shipping Weights - Motors (Models 35 - 125)	18
Table 7: Cabinet Dimensions (Models 150 - 450)	18
Table 8: Estimated Shipping Weights (Models 150 - 450)	19
Table 9: Estimated Shipping Weights - Burners (Models 150 - 450).....	19
Table 10: Estimated Shipping Weights - Motors (Models 150 - 450)	20
Table 11: Model Number and Capacity	20
Table 12: Blower Motor Horsepower Selection (Includes Drive Losses)	21
Table 13: Sound Data	24
Table 14: Roof Seam Cover Drill Screws	27
Table 15: Roof Curb Dimensions	42
Table 16: Roof Curb Weights	43
Table 17: Lag Bolts	64
Table 18: Minimum Discharge Duct Connection Size	69
Table 19: Combustion Air Duct Collar Sizing	74
Table 20: Gas Manifold Size	78
Table 21: Control Voltage Wiring For All Control Systems.....	92
Table 22: Safety Systems.....	93
Table 23: Configuration Chart	122
Table 24: Deflection Force of V-Belts.....	132
Table 25: Motor Lubrication Intervals	141

There are references in this manual to various trademarks. All trademarks mentioned herein, whether registered or not, are the property of their respective owners. Roberts-Gordon LLC is not sponsored by or affiliated with any of the trademark or registered trademark owners, and makes no representations about them, their owners, their products or services.



SECTION 1: AIR HANDLER SAFETY



Your Safety is Important to Us!
This symbol is used throughout the manual to notify you of possible fire, electrical or burn hazards. Please pay special attention when reading and following the warnings in these sections.

Installation, service and at a minimum, annual inspection of air handler must be done by a contractor qualified in the installation and service of gas-fired and/or oil-fired heating equipment.

Read this manual carefully before installation, operation or service of this equipment.

This air handler is designed for heating non-residential indoor spaces. Do not install in residential spaces. These instructions, the layout drawing, local codes and ordinances and applicable standards that apply to fuel piping, electrical wiring, ventilation, etc. must be thoroughly understood before proceeding with the installation.

Protective gear is to be worn during installation, operation and service. Thin sheet metal parts have sharp edges. To prevent injury, the use of work gloves is recommended.

Before installation, check that the local distribution conditions, nature of fuel and pressure and adjustment of the appliance are compatible.

This equipment must be applied and operated under the general concepts of reasonable use and installed using best building practices.

This appliance is not intended for use by persons (including children) with reduced physical, sensory or mental capabilities, or lack of experience and knowledge, unless they have been given supervision or instruction concerning use of the appliance by a person responsible for their safety.

Children should be supervised to ensure that they do not play with the appliance.

For additional copies of the Installation, Operation and Service Manual, please contact Roberts-Gordon LLC.

Gas and oil-fired appliances are not designed for use in atmospheres containing flammable vapors, flammable dust or chlorinated or halogenated hydrocarbons. Recirculated room air may be hazardous if containing flammable solids, liquids, and gases; explosive materials; and/or substances which may become toxic when exposed to heat (i.e. refrigerants, aerosols, etc.).

1.1 Description of Operation

This air handler is an indirect, gas and/or oil-fired, appliance. It can be designed for indoor or outdoor installation. Air handlers are designed to operate in temperatures as low as -40° F (-40° C). The air handler is factory-tested to fire either with natural gas, LPG and/or fuel oil (check the air handler's rating plate for information on the appropriate fuel). The burner will operate to maintain discharge air temperature, room/space air temperature, or return air temperature depending on the selected controls. See *Page 122, Section 24*.

The air handler may be provided with several different controls and options to meet various application requirements. Be sure to read this entire manual before installation and start-up.

1.2 Inspection and Setup

The air handler is shipped in multiple sections based on the configuration selected. The air handler was inspected and operated prior to shipment. Immediately upon receipt of the air handler, check the fuel and electrical characteristics of the air handler and verify that they match the fuel and electrical supply available. Verify that the specifications on the air handler rating plate match your order. Check the air handler for any damage that may have occurred during shipment. If any damage is found, file a claim with the transporting agency. Do not refuse shipment. Check the installation location to ensure proper clearances to combustibles. See *Page 13, Section 3.1*.

Any small options which do not come attached to the air handler (i.e. remote panel or disconnect) will be found inside the air handler.

Larger accessories (i.e. stand and filter section) may either ship with the air handler or separately on another truck. Check the bill of lading for information.

If the air handler must be temporarily stored (i.e. job site is not ready for installation of the air handler), the air handler should be set on 4" x 4" (10 cm x 10 cm) pieces of timber on the ground in a protected area. The air handler should be covered to be protected from the environment.

1.3 Safety Labels and Their Placement

Product safety signs or labels should be replaced by product user when they are no longer legible. Please contact Roberts-Gordon LLC or your ROBERTS GORDON® independent distributor to obtain replacement signs or labels. See *Page 2, Figure 1 through Page 10, Figure 11*.

1.4 California Proposition 65

In accordance with California Proposition 65 requirements, a warning label must be placed in a highly visible location on the outside of the equipment (i.e., near equipment’s serial plate). See label placement drawings on Page 2, Figure 1 through Page 10, Figure 11 for label location. Avoid placing label on areas with extreme heat, cold, corrosive chemicals or other elements. To order additional labels, please contact Roberts-Gordon LLC or your ROBERTS GORDON® independent distributor.

1.5 Label Placement

FIGURE 1: Indoor Upright (Models 35 - 100)

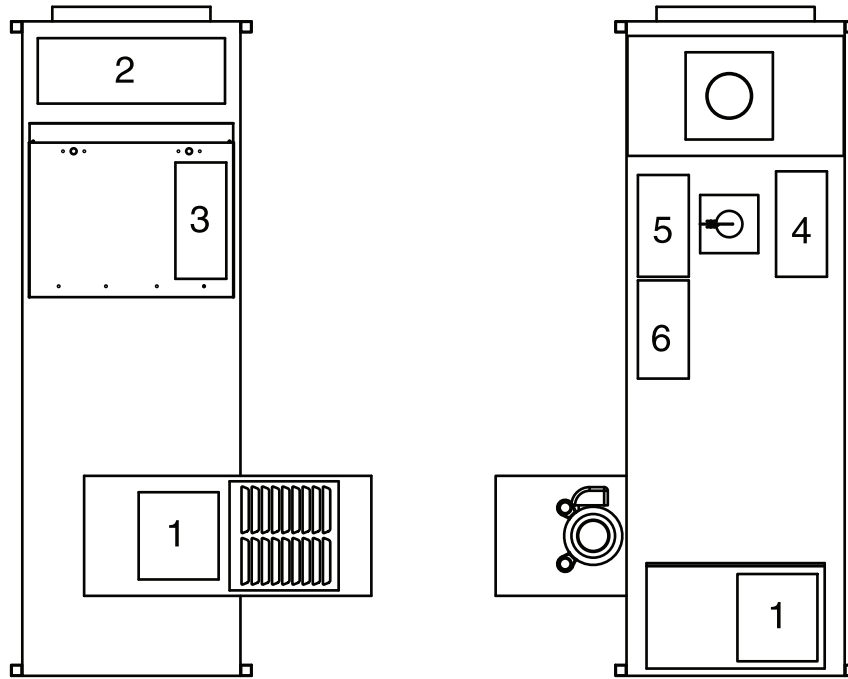

Item	Part Number	Description
1	91070002	Severe Injury Hazard Label
2	91040025	Logo Label
3	91070001	Electric Shock Hazard Label
4	91070004	Fire Hazard Label
5	91070006	Burn Hazard Label
6	91070005	Fall Hazard Label

FIGURE 2: Indoor Upright (Models 125 - 450)

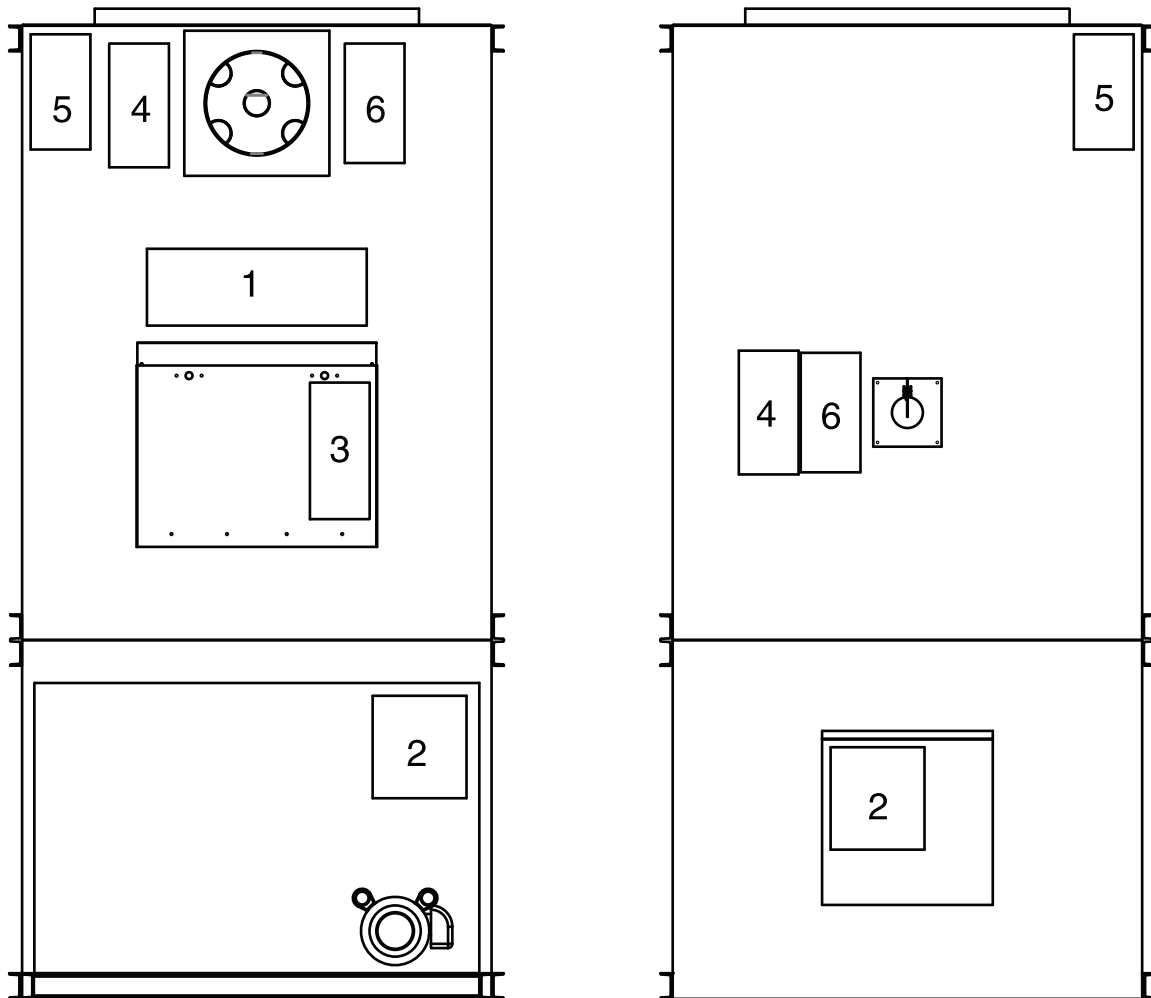

Item	Part Number	Description
1	91040025	Logo Label
2	91070002	Severe Injury Hazard Label
3	91070001	Electric Shock Hazard Label
4	91070004	Fire Hazard Label
5	91070005	Fall Hazard Label
6	91070006	Burn Hazard Label

FIGURE 3: Indoor Horizontal (Models 35 -100)

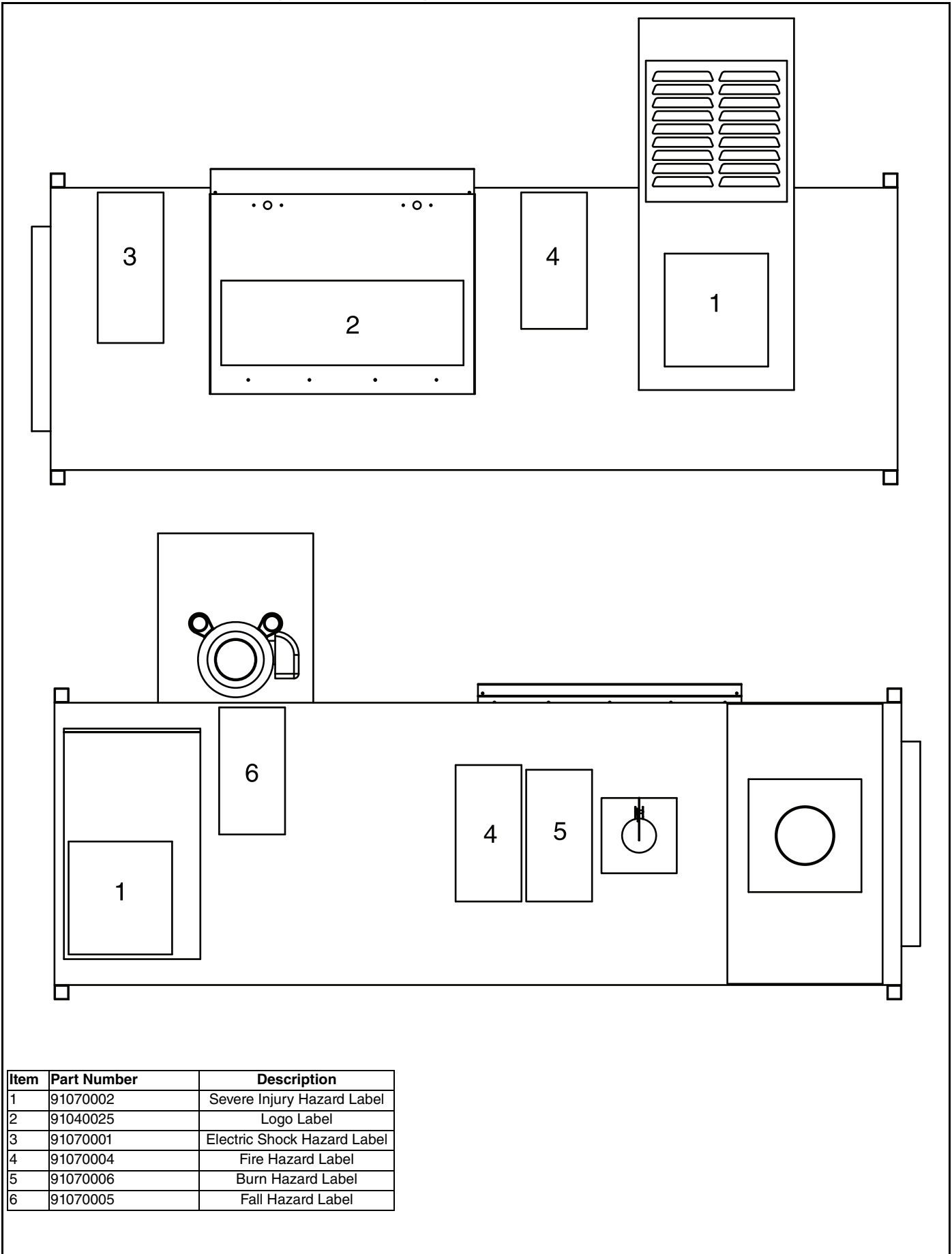
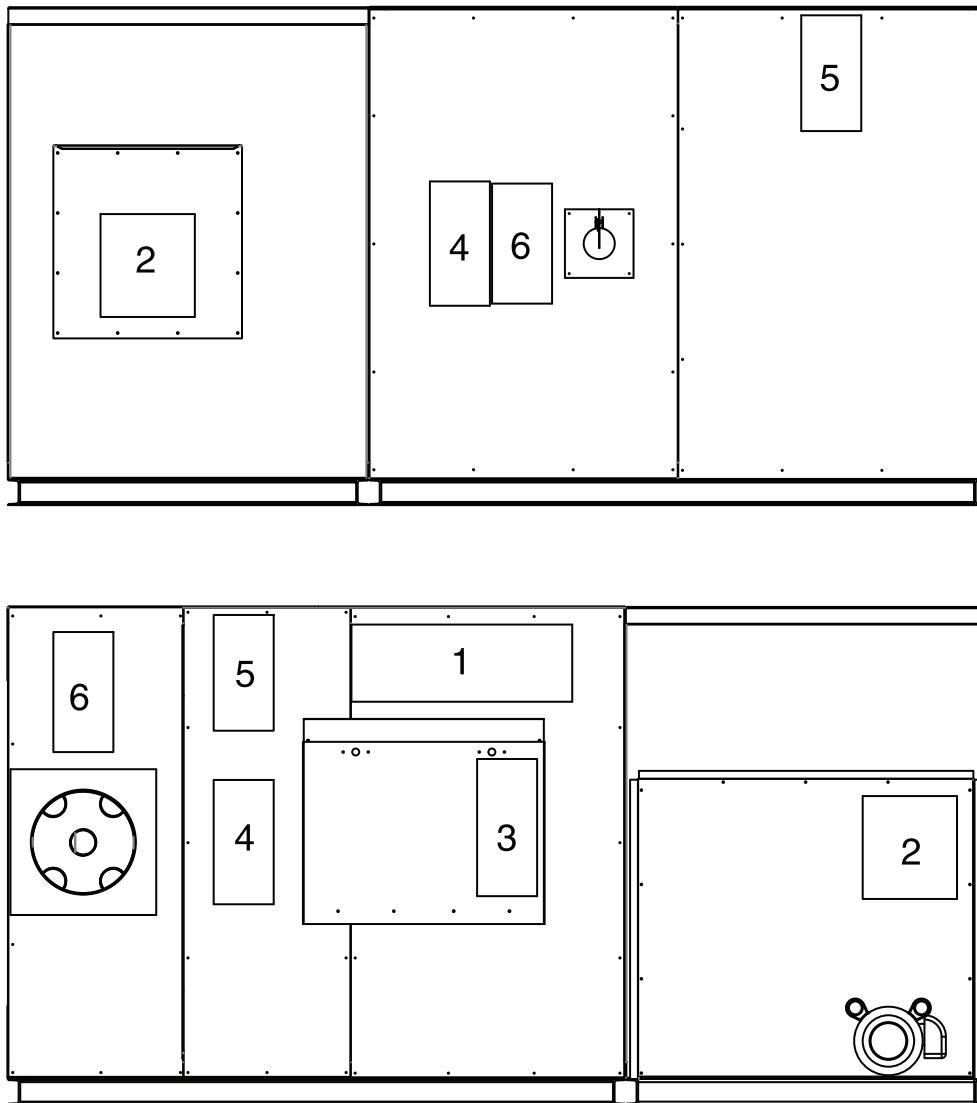
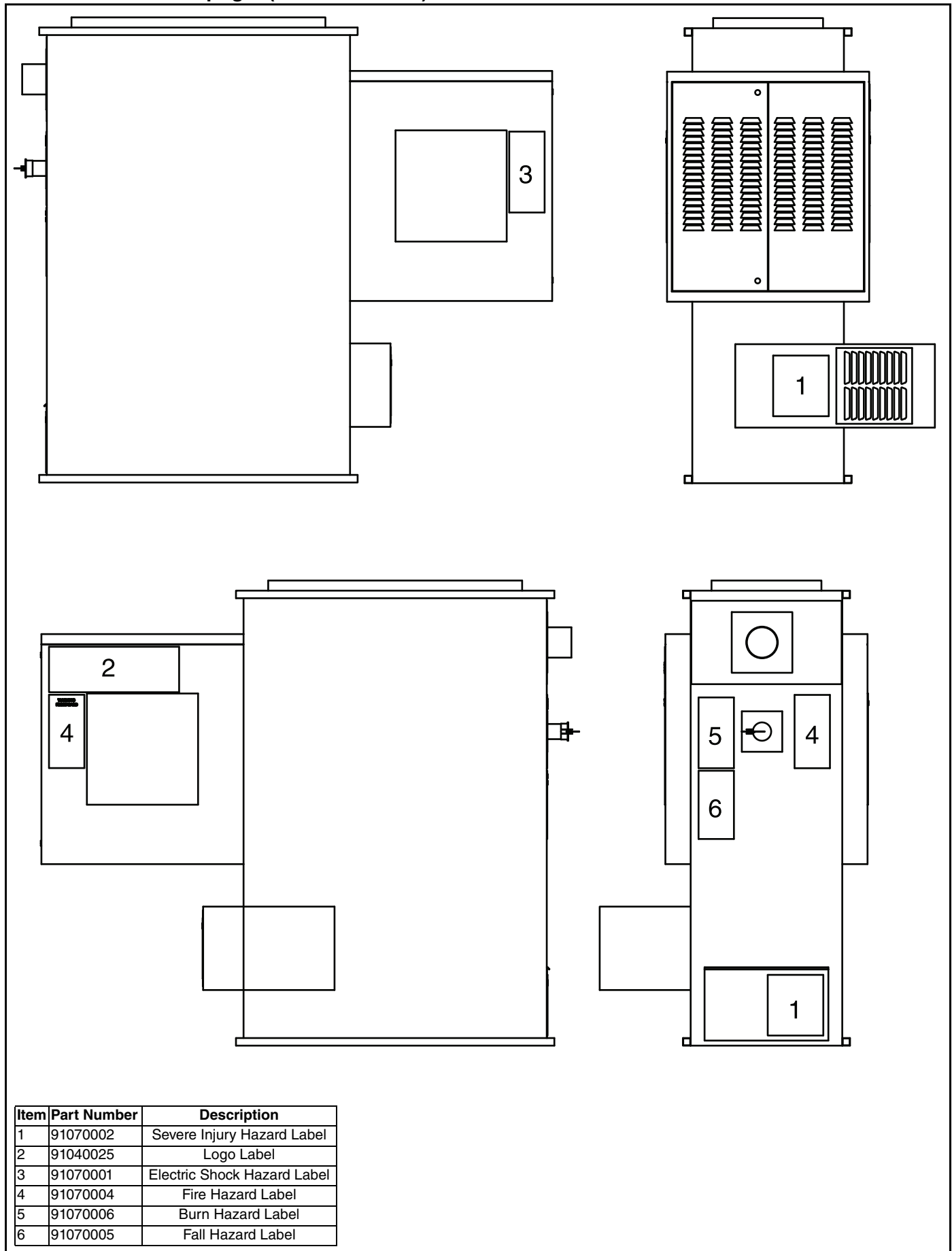

FIGURE 4: Indoor Horizontal (Models 125 - 450)



Item	Part Number	Description
1	91070002	Severe Injury Hazard Label
2	91040025	Logo Label
3	91070001	Electric Shock Hazard Label
4	91070004	Fire Hazard Label
5	91070006	Burn Hazard Label
6	91070005	Fall Hazard Label

FIGURE 5: Outdoor Upright (Models 35 - 100)



Item	Part Number	Description
1	91070002	Severe Injury Hazard Label
2	91040025	Logo Label
3	91070001	Electric Shock Hazard Label
4	91070004	Fire Hazard Label
5	91070006	Burn Hazard Label
6	91070005	Fall Hazard Label

FIGURE 6: Outdoor Upright (Models 125 - 400)

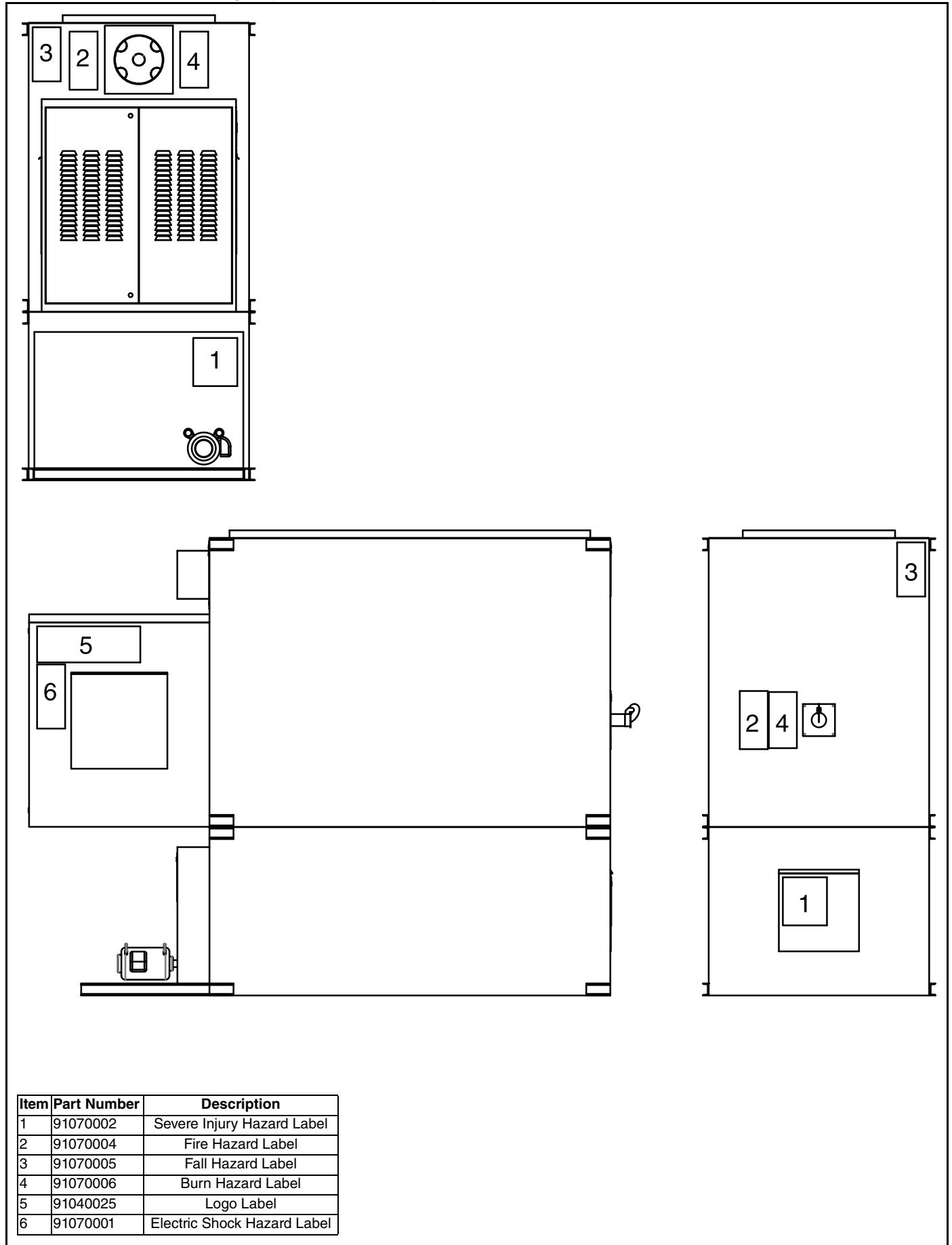

FIGURE 7: Outdoor Horizontal (Models 35 - 100)

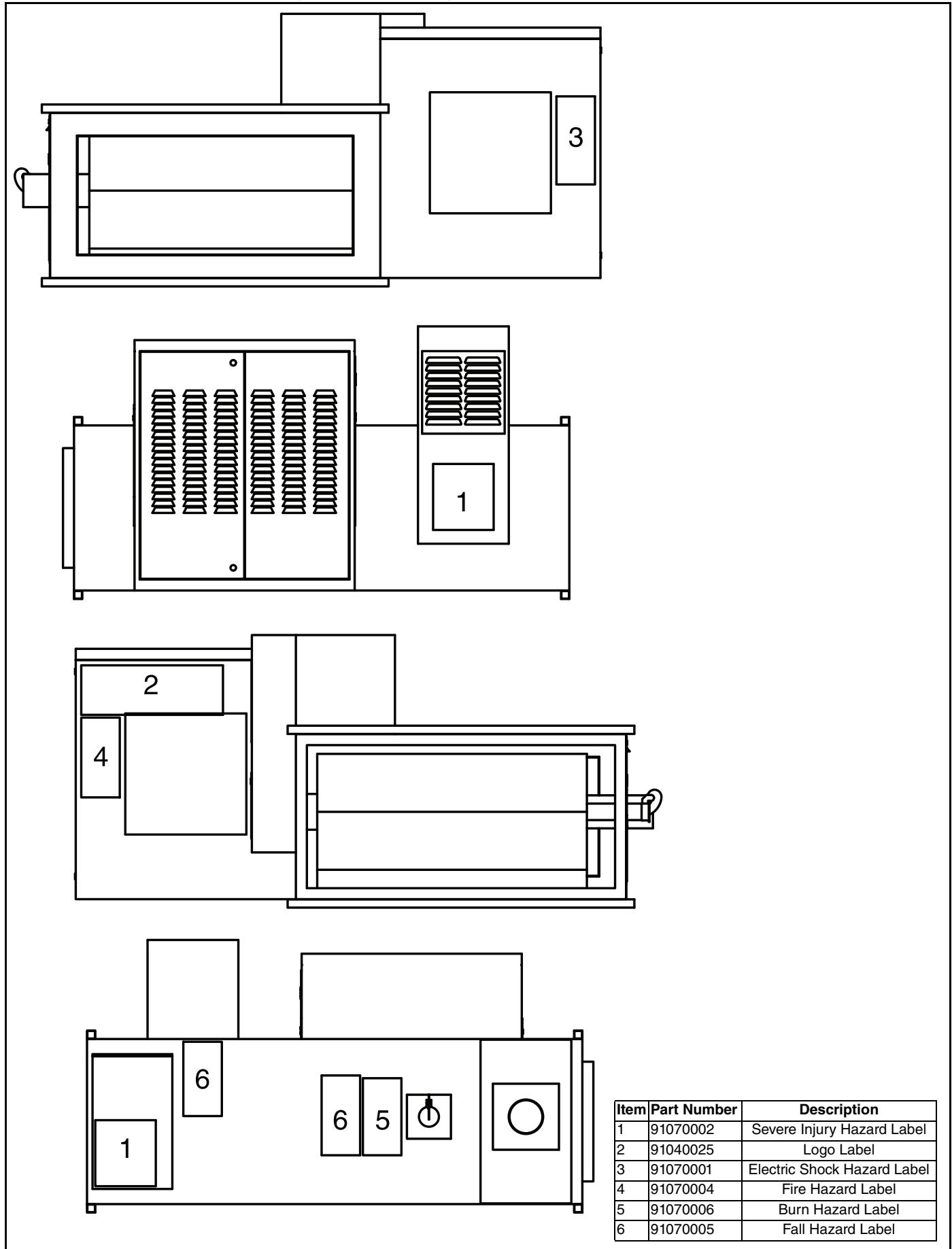
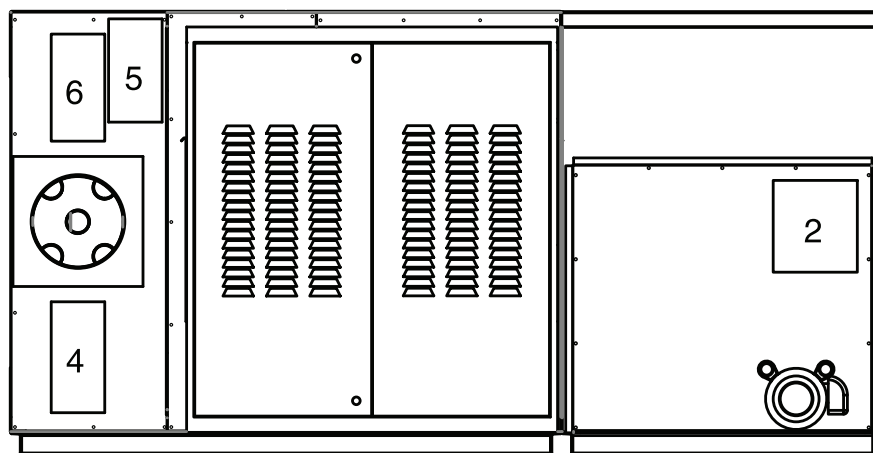
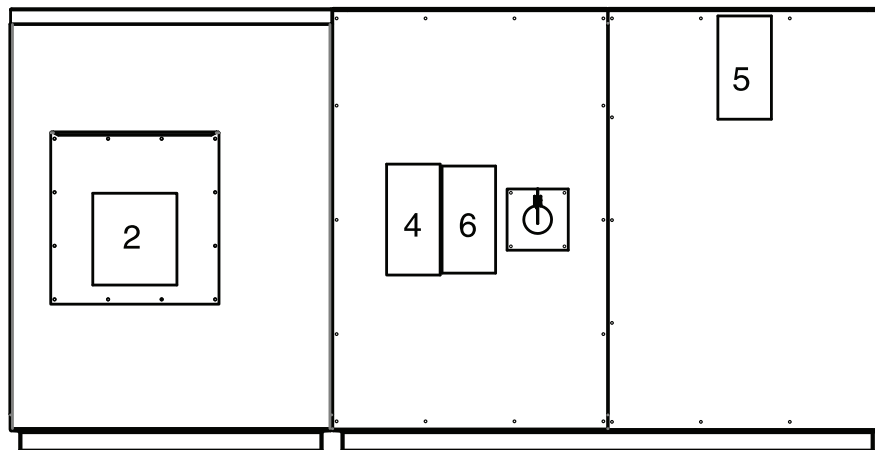
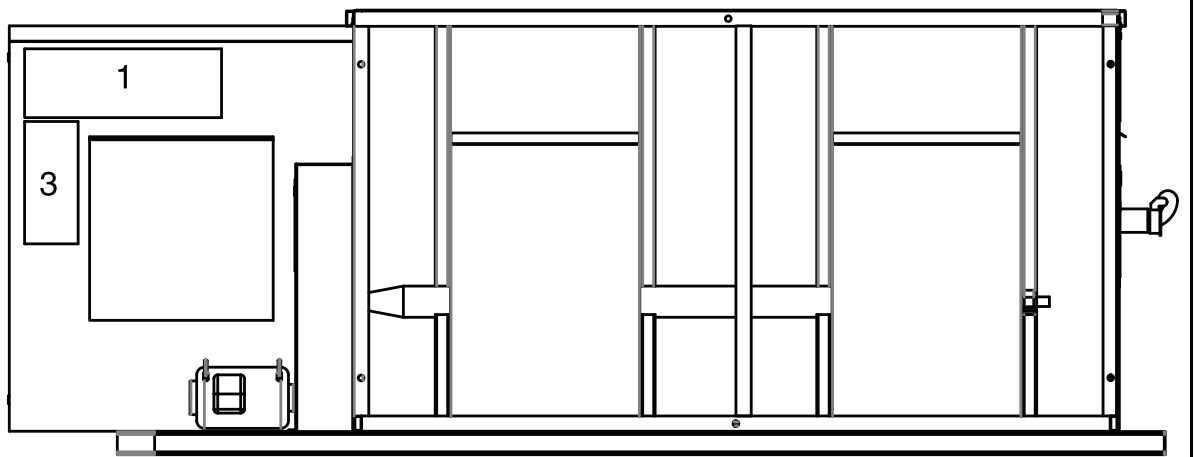

FIGURE 8: Outdoor Horizontal (Models 125 - 400)



Item	Part Number	Description
1	91040025	Logo Label
2	91070002	Severe Injury Hazard Label
3	91070001	Electric Shock Hazard Label
4	91070004	Fire Hazard Label
5	91070005	Fall Hazard Label
6	91070006	Burn Hazard Label

FIGURE 9: Control Enclosure Door (Inside)

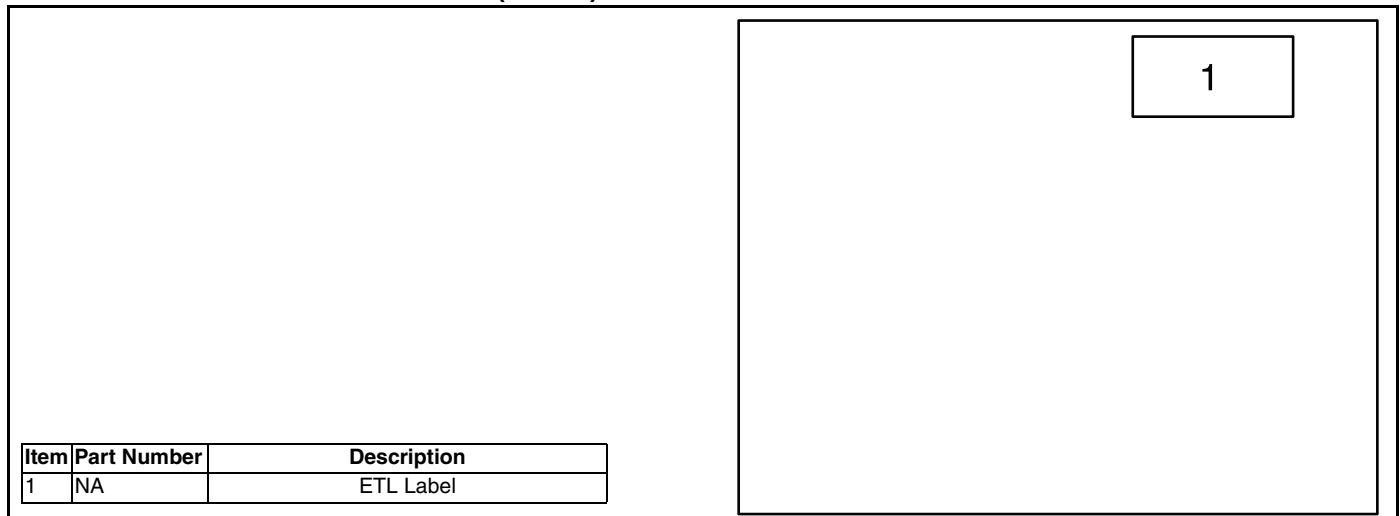

FIGURE 10: 8.1 Remote Panel

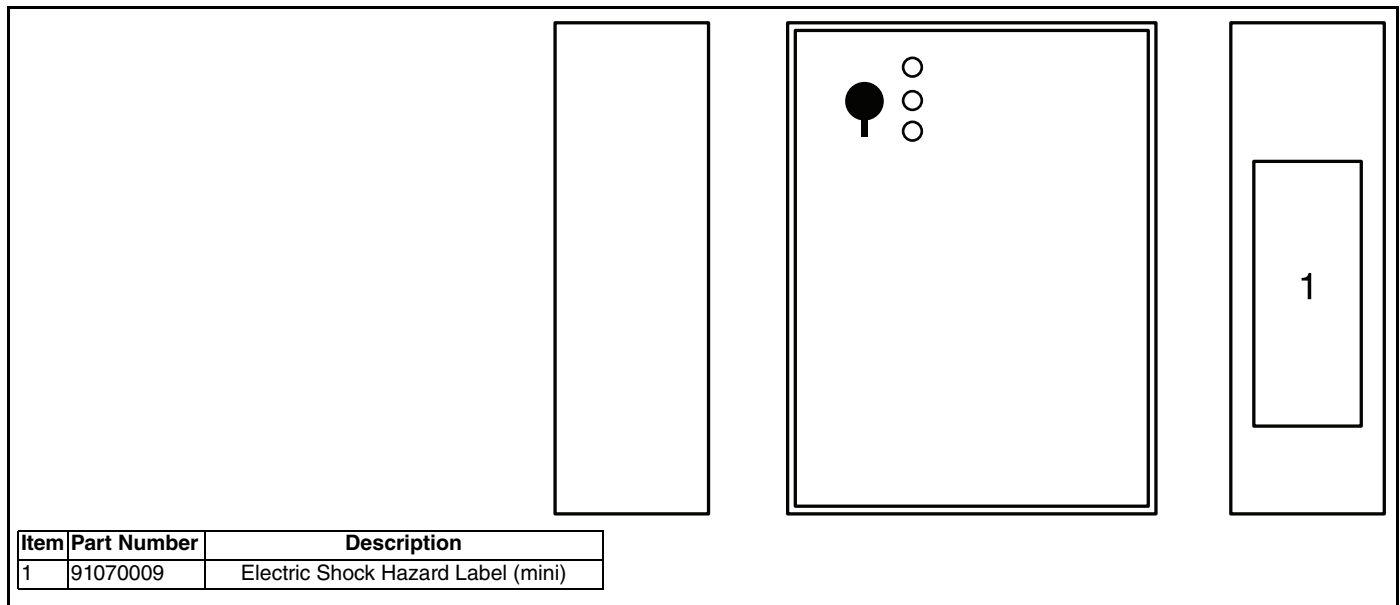
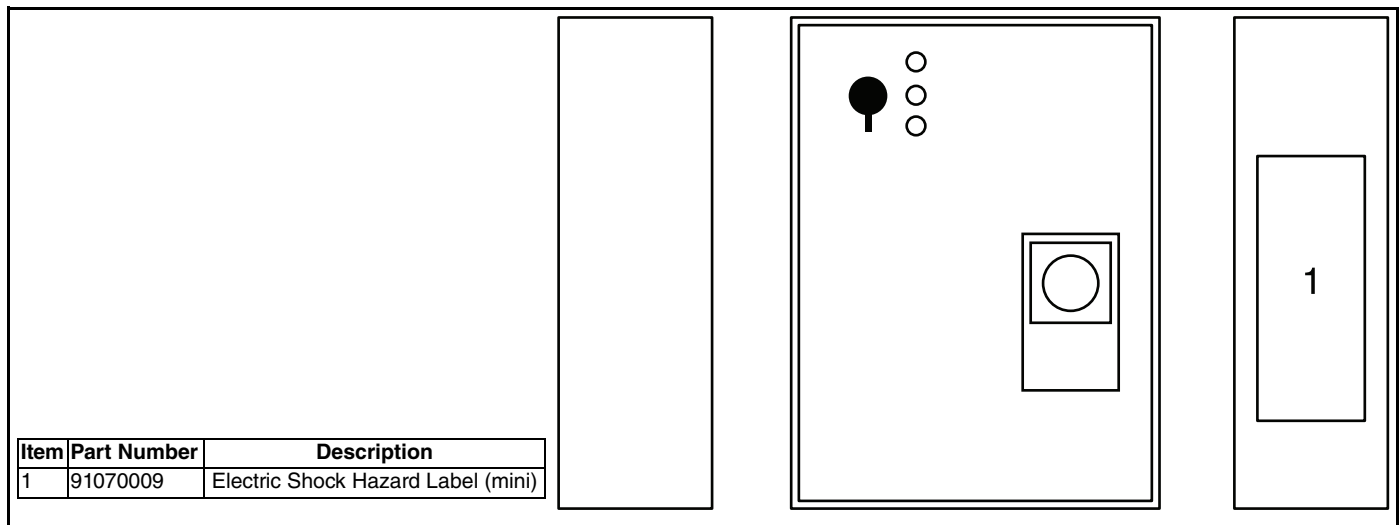

FIGURE 11: 8.5 Remote Panel



SECTION 2: INSTALLER RESPONSIBILITY

 <b style="font-size: 1.2em;">WARNING

<p style="text-align: center;">Explosion Hazard</p> <p>Equipment must have access to uncontaminated air at all times.</p> <p>Failure to follow these instructions can result in death, injury or property damage.</p>

- To assemble or install any accessories or associated duct work using best building practices.
- To properly size supports and hanging materials.

The installer is responsible for the following:

- To install and commission the air handler, as well as the fuel and electrical supplies, in accordance with applicable specifications and codes. Roberts-Gordon LLC recommends the installer contact a local building inspector or Fire Marshal for guidance.
- To use the information given in a layout drawing and in the manual together with the cited codes and regulations to perform the installation.
- To furnish all needed materials not furnished as standard equipment.
- To plan location of supports.
- To provide access to air handler for servicing.
- To provide the owner with a copy of this Installation, Operation and Service Manual.
- To ensure there is adequate air circulation around the air handler and to supply air for combustion, ventilation and distribution in accordance with local codes. The burners used on the air handlers require pressure-neutral air for proper combustion and performance. A burner's combustion air should not be attempted to be pulled from a negative air pressure environment. To avoid creating a negative pressure environment in a well-sealed space, there should be a fresh air penetration in the wall or roof of the space of a minimum size equivalent to 0.5 sq in (3.2 sq cm) per 1,000 Btu/h (293.1 kW) input capacity of equipment in the space. For information on pulling combustion air from outside of the unit's immediate vicinity, see *Page 73, Section 19.3*.

2.1 Corrosive Chemicals

<p>Product Damage Hazard</p> <p>Do not use equipment in area containing corrosive chemicals.</p> <p>Refer to appropriate Material Safety Data Sheets (MSDS).</p> <p>Failure to follow these instructions can result in product damage.</p>

Roberts-Gordon LLC cannot be responsible for ensuring that all appropriate safety measures are undertaken prior to installation; this is entirely the responsibility of the installer. It is essential that the contractor, the sub-contractor, or the owner identifies the presence of combustible materials, corrosive chemicals or halogenated hydrocarbons* anywhere in the premises.

* **Halogenated Hydrocarbons** are a family of chemical compounds characterized by the presence of halogen elements (fluorine, chlorine, bromine, etc.). These compounds are frequently used in refrigerants, cleaning agents, solvents, etc. If these compounds enter the air supply of the burner, the life span of the air handler components will be greatly reduced. An outside air supply must be provided to the burners whenever the presence of these compounds is suspected. Warranty will be invalid if the air handler is exposed to halogenated hydrocarbons.

2.2 Required Equipment and Materials

When lifting of the equipment is required, the installing contractor is responsible for supplying or arranging for the appropriate lifting equipment so that the air handler and accessories may be placed in a safe manner.

The qualified installing / service technician is responsible for having the appropriate equipment and materials for the safe installation and start-up of an indirect-fired air handler. Tools and materials required to commission the equipment include, but are not limited to, the following:

- Various screwdriver types and sizes
- Various adjustable wrenches
- Torque wrenches
- Pipe wrenches sized appropriately for the gas train components
- Drill motor and various drills
- U-tube manometer 0 to 6" wc (0 to 14.9 mbar)
- Gas pressure gauge 0 to 30" wc (0 to 74.7 mbar)
- Gas pressure gauge to suit building supply pressure conditions
- Oil pressure gauge 0 to 300 PSIG (0 to 20 bar)
- Combustion analyzer
- Stack thermometer
- Oil smoke tester
- Volt meter
- Clamp style ammeter
- Belt tension gauge
- Paintable latex caulk (Silicone caulk is not to be used)

SECTION 3: CRITICAL CONSIDERATIONS

! WARNING



Fire Hazard

Keep all flammable objects, liquids and vapors the minimum required clearances to combustibles away from equipment.

Some objects will catch fire or explode when placed close to equipment.

Failure to follow these instructions can result in death, injury or property damage.

Clearances to combustibles do not denote clearances for accessibility. Minimum clearance for access is 48" (122 cm). Minimum clearance for accessibility applies to the control enclosure, blower access panel and filter access panel (when equipped).

The stated clearances to combustibles represent a surface temperature of 90° F (32° C) above room temperature. Building materials with a low heat tolerance (i.e. plastics, vinyl siding, canvas, tri-ply, etc.) may be subject to degradation at lower temperatures. It is the installer's responsibility to assure that adjacent materials are protected from degradation. Maintain clearances from heat sensitive material, equipment and workstations.

- Maintain clearances from vehicles parked below. See *Page 15, Section 4.4.*

3.1 Required Clearances to Combustibles

Clearances are the required distances that combustible objects must be away from the air handler to prevent fire hazards. Combustibles are materials that may catch on fire and include common items such as wood, paper, rubber, fabric, etc.

Maintain clearances to combustibles at all times for safety.

Check the clearances on each air handler being installed to make sure the product is suitable for your application and the clearances are maintained.

Minimum clearances for all models are as follows:

- 18" (45.7 cm) Above the top of the equipment
- 18" (45.7 cm) Along the sides of the equipment
- 36" (91.4 cm) Around the flue pipe
- 36" (91.4 cm) Around the sight port
- 18" (45.7 cm) From the base rail of the equipment (when suspended) or installed on combustible floor.

Read and follow the safety guidelines below:

- Locate the air handler so that the air intakes are not too close to any exhaust fan outlets, gasoline storage, propane tanks or other contaminants that could potentially cause dangerous situations.
- Keep gasolines or other combustible materials including flammable objects, liquids, dust or vapors away from this air handler or any other appliance.
- Maintain clearances from heat sensitive material, equipment and workstations.

3.2 Hardware

Unless otherwise specified, all hardware must be torqued to settings from *Page 13, Table 1.*

Table 1: Recommended Torque Settings

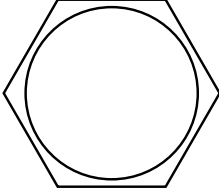
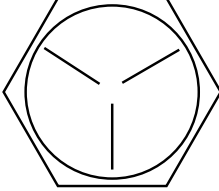
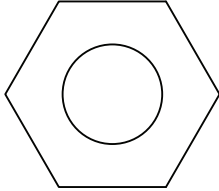
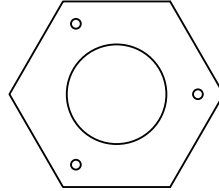
Bolt Head Grade Marking		
Nut Grade Marking		
Bolt Size	Grade 2	Grade 5
10-24	27 in•Lb	42 in•Lb
1/4-20	65 in•Lb	101 in•Lb
5/16-18	11 ft•Lb	17 ft•Lb
3/8-16	19 ft•Lb	30 ft•Lb

SECTION 4: NATIONAL STANDARDS AND APPLICABLE CODES

4.1 Fuel Codes

The type of fuel appearing on the nameplate must be the type of fuel used. Installation must comply with national and local codes and requirements of the local fuel company.

United States: Refer to NFPA 54/ANSI Z223.1 - latest revision, National Fuel Gas Code for natural gas and LPG units. Refer to NFPA 31- latest revision, Standard for the Installation of Oil-Burning Equipment for oil units.

Canada: Refer to CSA B149.1 - latest revision, Natural Gas and Propane Installation Code for natural gas and LPG units. Refer to CSA B139 - latest revision, Installation Code for Oil-Burning Equipment for oil units.

4.2 Installation Codes

Installations must be made in accordance with NFPA 90A - latest revision, Standard for the Installation of Air-Conditioning and Ventilation Systems.

4.3 Aircraft Hangars

Installation in aircraft hangars must be in accordance with the following codes:

United States: Refer to Standard for Aircraft Hangars, NFPA 409 - latest revision.

Canada: Refer to Standard CSA B149.1 - latest revision, Natural Gas and Propane Installation Code for natural gas and LPG units. Refer to CSA B139 - latest revision, Installation Code for Oil-Burning Equipment for oil units.

- In aircraft storage and servicing areas, air handlers shall be installed at least 10' (3 m) above the upper surface of wings or of engine enclosures of the highest aircraft which may be housed in the hangar. The measurement shall be made from the wing of the engine enclosure (whichever is higher from the floor) to the bottom of the air handler.
- In shops, offices and other sections of aircraft hangars communicating with aircraft storage or servicing areas, air handlers shall be installed not less than 8' (2.4 m) above the floor.
- Suspended or elevated air handlers shall be so located in all spaces of aircraft hangars that they shall not be subject to injury by aircraft, cranes, movable scaffolding or other objects. Provisions shall be made to assure accessibility to suspended air handlers for recurrent maintenance purposes.
- Heating, ventilation and air conditioning plants employing recirculation of air within aircraft storage and servicing areas shall have return air openings not less than 10' (3 m) above the floor. Supply air openings shall not be installed in the floor and shall be at least 6" (152 mm) from the floor measured to the bottom of the opening.
- Personnel should be fully instructed that in the event of a serious gasoline or similar flammable liquid spill on the hangar floor, the fans should be shut off.

4.4 Parking Structures and Repair Garages

Installation in garages must be in accordance with the following codes:

United States: Standard for Parking Structures NFPA 88A - latest revision or the Code for Motor Fuel Dispensing Facilities and Repair Garages, NFPA 30A - latest revision.

Canada: Refer to CSA B149.1 - latest revision, Natural Gas and Propane Installation Code for natural gas and LPG units. Refer to CSA B139 - latest revision, Installation Code for Oil-Burning Equipment for oil units.

- Air handlers must not be installed less than 8' (2.4 m) above the floor. Minimum clearances to combustibles must be maintained from vehicles parked below the air handler.
- When installed over hoists, minimum clearances to combustibles must be maintained from the upper most point of objects on the hoist.

4.5 Electrical

Electrical connection to air handler must be in accordance with the following codes:

United States: Refer to National Electrical Code®, NFPA 70 - latest revision. Wiring must conform to the most current National Electrical Code®, local ordinances, and any special diagrams furnished.

Canada: Refer to Canadian Electrical Code, CSA C22.1 Part 1 - latest revision.

4.6 Venting

This air handler must be vented in accordance with the requirements within this manual and with the following codes and any state, provincial or local codes which may apply:

United States: Refer to NFPA 54/ANSI Z223.1- latest revision, National Fuel Gas Code for natural gas and LPG units. Refer to NFPA 31 - latest revision, Standard for the Installation of Oil-Burning Equipment for oil units.

Canada: Refer to CSA B149.1 - latest revision, Natural Gas and Propane Installation Code for natural gas and LPG units. Refer to CSA B139 - latest revision, Installation Code for Oil-Burning Equipment for oil units.

4.7 High Altitude

These air handlers are approved for installations up to 2000' (609.6 m) (US), 4500'(1371.6 m) (Canada) without modification. Consult factory if US installation is above 2000' (609.6 m) or Canadian installation is above 4500'(1371.6 m).

SECTION 5: SPECIFICATIONS

Dimension and estimated weight tables apply to both upright and horizontal air handlers of the same model.

The maximum total static pressure (TSP) is listed by model in on Page 21, Table 12. To calculate the available external static pressure (ESP), calculate the internal static pressure (ISP) with the use of Figures 16 and 17 and then subtract that value from the TSP. If more ESP is required, this needs to be requested with the order as the required motor

horsepower (HP) may increase from the specifications given.

The legend below is a list of abbreviations used in this section and applies to Page 16, Figure 12 through Page 19, Figure 15.

Table 2: Legend

BD = Bottom Discharge	OA = Outside Air
TD = Top Discharge	LD = Left Discharge
RA = Return Air	ED = End Discharge
RD = Right Discharge	

FIGURE 12: Upright Model Dimensions (Models 35 - 125)

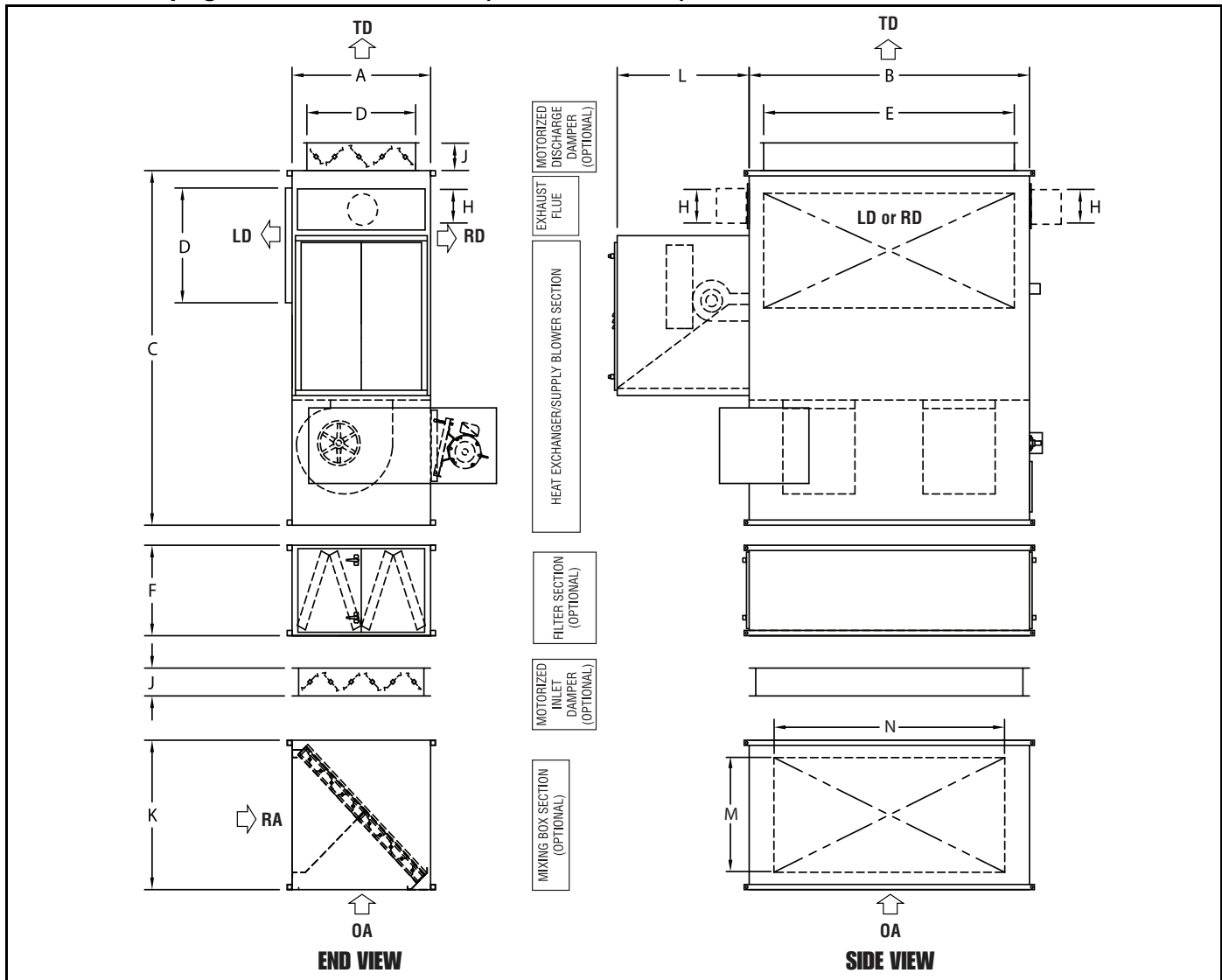

Table 3: Cabinet Dimensions (Models 35 - 125)

Model	A	B	C	D	E	F	G	H	J	K	L	M	N	Filter Size	
35/45	(in)	30	60	90	21.5	50	28	38	6	8	43	40	21.5	50	60 - 20 x 20 x 2 60 - 50.8 x 50.8 x 5.1
	(cm)	76.2	152.4	228.6	54.6	127.0	71.1	96.5	15.2	20.3	109.2	101.6	54.6	127.0	
50/65/75	(in)	28	72	80	21.5	58	28	38	6	8	43	40	21.5	58	4 - 20 x 25 x 2 and 4 - 16 x 25 x 2 4 - 50.8 x 63.5 x 5.1 and 4 - 40.6 x 63.5 x 5.1
	(cm)	71.1	182.9	203.2	54.6	147.3	71.1	96.5	15.2	20.3	109.2	101.6	54.6	147.3	
85/100	(in)	36	72	90	26	58	24	48	8	8	43	40	33	58	8 - 20 x 20 x 2 and 8 - 16 x 20 x 2 8 - 50.8 x 50.8 x 5.1 and 8 - 40.6 x 50.8 x 5.1
	(cm)	91.4	182.9	228.6	66.0	147.3	60.9	121.9	20.3	20.3	109.2	101.6	83.8	147.3	
125	(in)	42	85	102	33	76	26	48	10	8	43	40	33	70	16 - 20 x 16 x 2 and 4 - 20 x 20 x 2 16 - 50.8 x 40.6 x 5.1 and 4 - 50.8 x 50.8 x 5.1
	(cm)	106.7	215.9	259.1	83.8	193.0	66.0	121.9	25.4	20.3	109.2	101.6	83.8	177.8	

FIGURE 13: Horizontal Model Dimensions (Models 35 - 125)

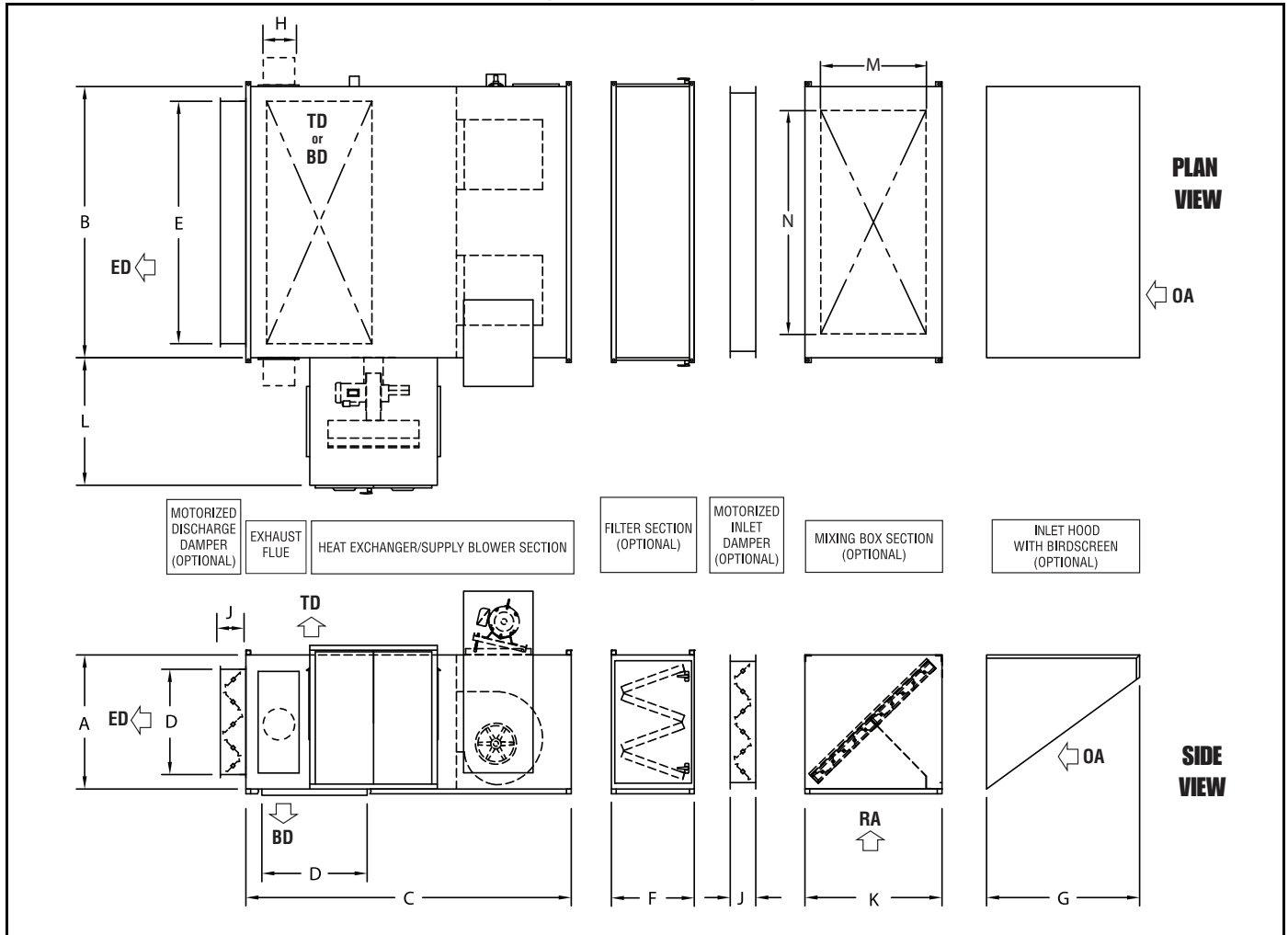

Table 4: Estimated Shipping Weights (Models 35 - 125)

Model	Housings				Filters	Dampers		Weatherizing		Service Platform		
	Heat Exchanger	Blower	Coil Section	Mix Box	V-Bank	Inlet	Discharge	Fresh Air Hood	Blower H-Exch	Blower H-Exch	Addtl. Section	
35/45/50/65/75	(lb)	1,000	540	375	445	420	240	240	80	100	480	240
	(kg)	453.6	244.9	170.1	201.8	190.5	108.9	108.9	36.3	45.4	217.7	108.9
85/100	(lb)	1,440	800	575	685	650	330	330	130	100	680	470
	(kg)	653.2	362.9	260.8	310.7	294.8	149.7	149.7	59	45.4	308.4	213.2
125	(lb)	1,819	1,337	800	880	500	400	400	155	150	800	470
	(kg)	825.1	606.5	362.9	399.2	226.8	181.4	181.4	70.3	68	362.9	213.2

Table 5: Estimated Shipping Weights - Burners (Models 35 - 125)

Gas Burner	Input MBH	300 - 625	626 - 938	939 - 1250	1251 - 1875	1876 - 2500	2501 - 3125	3126 - 5000
	Input kW	87.9 - 183.2	183.3 - 274.9	275.0 - 366.3	366.4 - 539.5	539.6 - 732.7	732.8 - 915.8	915.9 - 1465.4
#2 Oil Burner	Input GPH	2.5 - 4.5	4.6 - 6.7	6.8 - 8.9	9.0 - 13.4	13.5 - 17.9	18.0 - 22.0	22.1 - 36.0
	Input LPH	9.5 - 17.0	17.1 - 25.4	25.5 - 33.7	33.8 - 50.7	50.8 - 67.8	67.9 - 83.3	83.4 - 136.3
Combination Gas / #2 Oil Burner	Weight (lb)	155	190	230	290	300	340	340
	Weight (kg)	70.3	86.2	104.3	131.5	136.1	154.2	154.2
	Input MBH	300 - 625	626 - 938	939 - 1250	1251 - 1875	1876 - 2500	2501 - 3125	3126 - 5000
	Input kW	87.9 - 183.2	183.3 - 274.9	275.0 - 366.3	366.4 - 539.5	539.6 - 732.7	732.8 - 915.8	915.9 - 1465.4
Combination Gas / #2 Oil Burner	Input GPH	2.5 - 4.5	4.6 - 6.7	6.8 - 8.9	9.0 - 13.4	13.5 - 17.9	18.0 - 22.0	22.1 - 36.0
	Input LPH	9.5 - 17.0	17.1 - 25.4	25.5 - 33.7	33.8 - 50.7	50.8 - 67.8	67.9 - 83.3	83.4 - 136.3
Combination Gas / #2 Oil Burner	Weight (lb)	125	125	220	220	310	360	385
	Weight (kg)	56.7	56.7	99.8	99.8	140.6	163.3	174.6
Combination Gas / #2 Oil Burner	Weight (lb)	200	240	270	360	400	450	500
	Weight (kg)	90.7	108.9	122.5	163.3	181.4	204.1	226.8

Table 6: Estimated Shipping Weights - Motors (Models 35 - 125)

Size HP		.75	1	1.5	2	3	5	7.5	10	15	20	25	30	40	50	60	75
Standard Weight	(lb)	35	35	45	45	70	85	130	155	220	275	300	360	500	550	800	950
	(kg)	15.9	15.9	20.4	20.4	31.8	38.6	59	70.3	99.8	124.7	136.1	163.3	226.8	249.5	362.9	430.9
2-Speed Weight	(lb)	70	85	125	150	185	215	270	310	405	455	525	570	700	760	N/A	N/A
	(kg)	31.8	38.6	56.7	68	83.9	97.5	122.5	140.6	183.7	206.4	238.1	258.5	317.5	344.7	N/A	N/A

FIGURE 14: Upright Model Dimensions (Models 150 - 450)

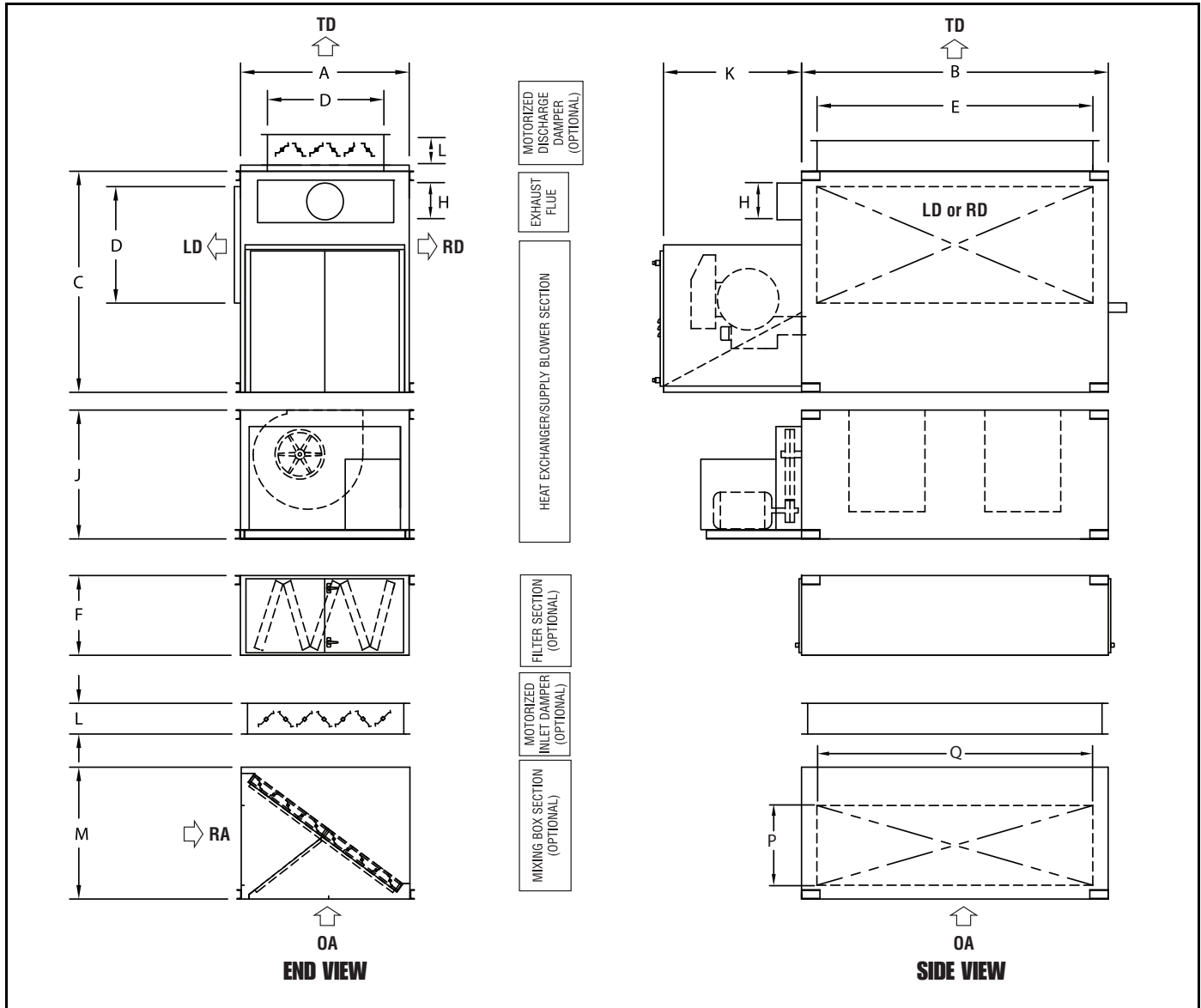

Table 7: Cabinet Dimensions (Models 150 - 450)

Model		A	B	C	D	E	F	H	J	K	L	M	N	P	Q	Filter Size
150/175	(in)	55	100	72	38	90	26	12	42	45	10	43	60	26	90	20 - 20 x 25 x 2
	(cm)	139.7	254.0	182.9	96.5	228.6	66.0	30.5	106.7	114.3	25.4	109.2	152.4	66.0	228.6	20 - 50.8 x 63.5 x 5.1
200/225	(in)	55	116	72	38	100	26	12	55	45	10	43	60	26	96	10 - 20 x 20 x 2 and 15 - 20 x 25 x 2
	(cm)	139.7	294.6	182.9	96.5	254.0	66.0	30.5	139.7	114.3	25.4	109.2	152.4	66.0	243.8	10 - 50.8 x 50.8 x 5.1 and 15 - 50.8 x 63.5 x 5.1
250/275/300	(in)	60	116	90	51	100	26	14	55	45	10	43	60	36	96	12 - 20 x 20 x 2 and 18 - 20 x 25 x 2
	(cm)	152.4	294.6	228.6	129.5	254.0	66.0	35.6	139.7	114.3	25.4	109.2	152.4	91.4	243.8	12 - 50.8 x 50.8 x 5.1 and 18 - 50.8 x 63.5 x 5.1
300/400/450	(in)	72	160	102	56	150	26	16	60	45	10	43	60	36	140	56 - 20 x 20 x 2
	(cm)	182.9	406.4	259.1	142.2	381	66.0	40.6	152.4	114.3	25.4	109.2	152.4	91.4	355.6	56 - 50.8 x 50.8 x 5.1

FIGURE 15: Horizontal Model Dimensions (Models 150 - 450)

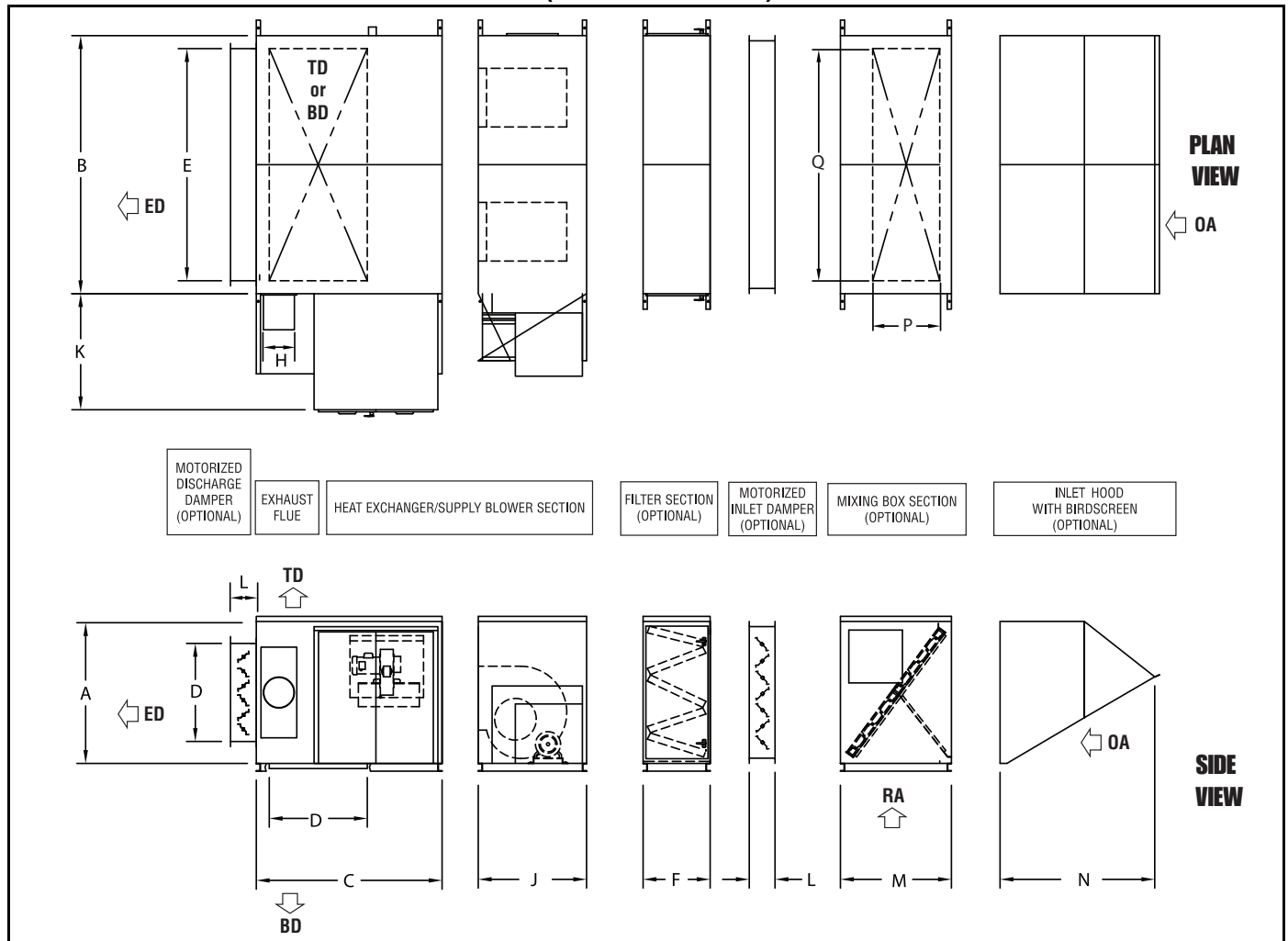

Table 8: Estimated Shipping Weights (Models 150 - 450)

Model	Housings				Filters	Dampers		Weatherizing		Service Platform	
	Heat Exchanger	Blower	Coil Section	Mix Box	V-Bank	Inlet	Discharge	Fresh Air Hood	Blower H-Exch	Blower H-Exch	Addtl. Section
150/175	(lb)	2,200	1,875	1,025	950	470	470	180	200	940	470
	(kg)	997.9	850.5	464.9	430.9	213.2	213.2	81.6	90.7	426.4	213.2
200/225/250/275	(lb)	3,200	2,500	1,300	1,325	1,100	550	240	275	1,100	550
	(kg)	1,451.5	1,134	589.7	601	499	249.5	108.9	124.7	499	249.5
300/350/400/450	(lb)	4,200	3,360	1,400	1,475	1,300	630	385	375	1,260	630
	(kg)	1,905.1	1,524.1	635	669	589.7	285.8	174.6	170.1	571.5	285.8

Table 9: Estimated Shipping Weights - Burners (Models 150 - 450)

Gas Burner	Input MBH	300 - 625	626 - 938	939 - 1250	1251 - 1875	1876 - 2500	2501 - 3125	3126 - 5000
	Input kW	87.9 - 183.2	183.3 - 274.9	275.0 - 366.3	366.4 - 539.5	539.6 - 732.7	732.8 - 915.8	915.9 - 1465.4
#2 Oil Burner	Weight (lb)	155	190	230	290	300	340	340
	Weight (kg)	70.3	86.2	104.3	131.5	136.1	154.2	154.2
Combination Gas / #2 Oil Burner	Input MBH	300 - 625	626 - 938	939 - 1250	1251 - 1875	1876 - 2500	2501 - 3125	3126 - 5000
	Input kW	87.9 - 183.2	183.3 - 274.9	275.0 - 366.3	366.4 - 539.5	539.6 - 732.7	732.8 - 915.8	915.9 - 1465.4
#2 Oil Burner	Input GPH	2.5 - 4.5	4.6 - 6.7	6.8 - 8.9	9.0 - 13.4	13.5 - 17.9	18.0 - 22.0	22.1 - 36.0
	Input LPH	9.5 - 17.0	17.1 - 25.4	25.5 - 33.7	33.8 - 50.7	50.8 - 67.8	67.9 - 83.3	83.4 - 136.3
Combination Gas / #2 Oil Burner	Weight (lb)	125	125	220	220	310	360	385
	Weight (kg)	56.7	56.7	99.8	99.8	140.6	163.3	174.6

Table 10: Estimated Shipping Weights - Motors (Models 150 - 450)

Motor Size	(HP)	.75	1	1.5	2	3	5	7.5	10	15	20	25	30	40	50	60	75
Standard Motor Weight	(lb) (kg)	35 15.9	35 15.9	45 20.4	45 20.4	70 31.8	85 38.6	130 59	155 70.3	220 99.8	275 124.7	300 136.1	360 163.3	500 226.8	550 249.5	800 362.9	950 430.9
2-Speed Motor Weight	(lb) (kg)	70 31.8	85 38.6	125 56.7	150 68	185 83.9	215 97.5	270 122.5	310 140.6	405 183.7	455 206.4	525 238.1	570 258.5	700 317.5	760 344.7	N/A	N/A

Table 11: Model Number and Capacity

Model	Heat Output				Heat Input				Blower Size		Airflow				Flue Diameter	
	Minimum		Maximum		Minimum		Maximum				Minimum		Maximum			
	Btu/h x 1000	kW	Btu/h x 1000	kW	Btu/h x 1000	kW	Btu/h x 1000	kW	(Qty) in	(Qty) cm	CFM	m³/h	CFM	m³/h	in	cm
35	240	70.3	350	102.6	300	87.9	435	127.5	(1) 15 x 15	(1) 38.1 x 38.1	3,500	5,947	6,000	10,194	6	15.2
45	240	70.3	450	131.9	300	87.9	560	164.1	(1) 15 x 15	(1) 38.1 x 38.1	3,500	5,947	6,000	10,194	6	15.2
50	240	70.3	500	146.5	300	87.9	630	184.6	(2) 12 x 12	(2) 30.5 x 30.5	4,000	6,796	8,000	13,592	6	15.2
65	520	152.4	650	190.5	640	187.6	810	237.4	(2) 12 x 12	(2) 30.5 x 30.5	4,000	6,796	8,000	13,592	6	15.2
75	520	152.4	750	219.8	650	190.5	940	275.5	(2) 15 x 15	(2) 38.1 x 38.1	6,000	10,194	12,000	20,388	6	15.2
85	520	152.4	850	249.1	650	190.5	1,060	310.7	(2) 15 x 15	(2) 38.1 x 38.1	6,000	10,194	12,000	20,388	8	20.3
100	520	152.4	1,000	293.1	650	190.5	1,250	366.3	(2) 15 x 15	(2) 38.1 x 38.1	6,000	10,194	12,000	20,388	8	20.3
125	560	164.1	1,250	366.3	700	205.1	1,565	458.7	(2) 18 x 18	(2) 45.7 x 45.7	10,000	16,990	18,000	30,582	10	25.4
150	560	164.1	1,500	439.6	700	205.1	1,880	551.0	(2) 20 x 20	(2) 50.8 x 50.8	13,000	22,087	24,000	40,776	12	30.5
175	600	175.8	1,750	512.9	750	219.8	2,190	641.8	(2) 20 x 20	(2) 50.8 x 50.8	13,000	22,087	24,000	40,776	12	30.5
200	600	175.8	2,000	586.1	750	219.8	2,500	732.7	(2) 25 x 25	(2) 63.5 x 63.5	21,000	35,679	37,000	62,863	14	35.6
225	600	175.8	2,250	659.4	750	219.8	2,800	820.6	(2) 25 x 25	(2) 63.5 x 63.5	21,000	35,679	37,000	62,863	14	35.6
250	600	175.8	2,500	732.7	750	219.8	3,130	917.3	(2) 25 x 25	(2) 63.5 x 63.5	21,000	35,679	45,000	76,455	14	35.6
275	720	211.0	2,750	805.9	900	263.8	3,440	1,008.2	(2) 25 x 25	(2) 63.5 x 63.5	21,000	35,679	45,000	76,455	14	35.6
300	720	211.0	3,000	879.2	900	263.8	3,750	1,099.0	(2) 25 x 25	(2) 63.5 x 63.5	30,000	50,970	45,000	76,455	14	35.6
350	720	211.0	3,500	1,025.7	900	263.8	4,380	1,283.7	(2) 30 x 30	(2) 76.2 x 76.2	35,000	59,465	57,000	96,844	16	40.6
400	1,400	410.3	4,000	1,172.3	1,750	512.9	5,000	1,465.4	(2) 30 x 30	(2) 76.2 x 76.2	35,000	59,465	57,000	96,844	16	40.6
450	1,400	410.3	4,500	1,318.8	1,750	512.9	5,600	1,641.2	(2) 30 x 30	(2) 76.2 x 76.2	35,000	59,465	57,000	96,844	16	40.6

FIGURE 16: Percentage of Airflow Capacity

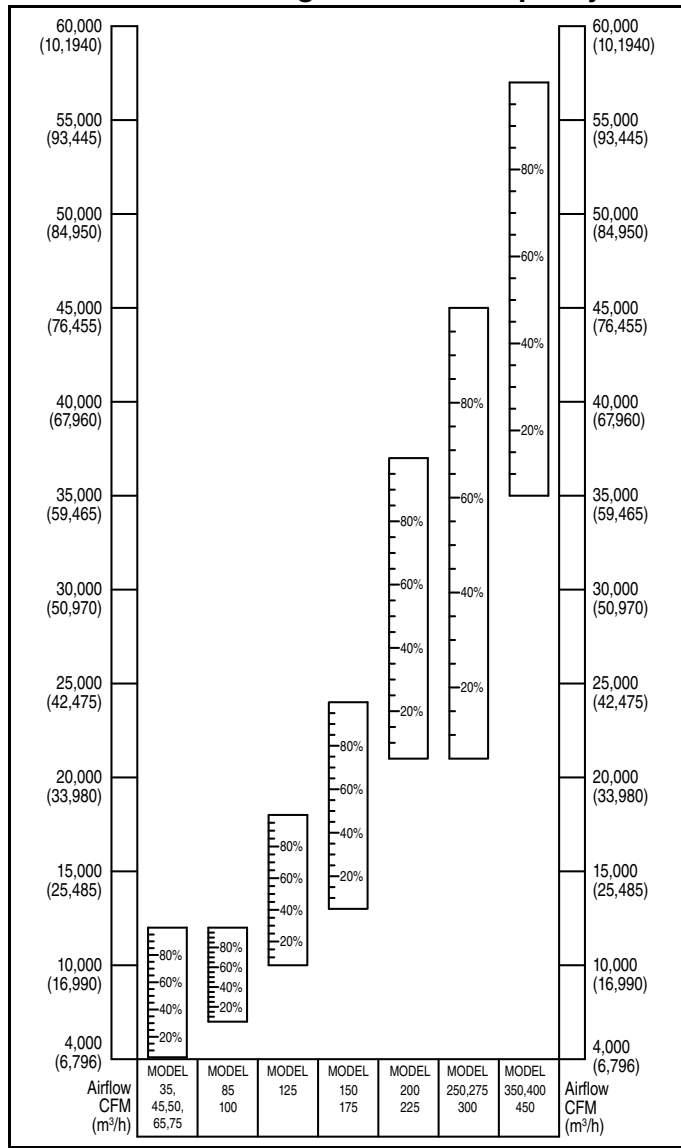

FIGURE 17: Internal Static Pressure

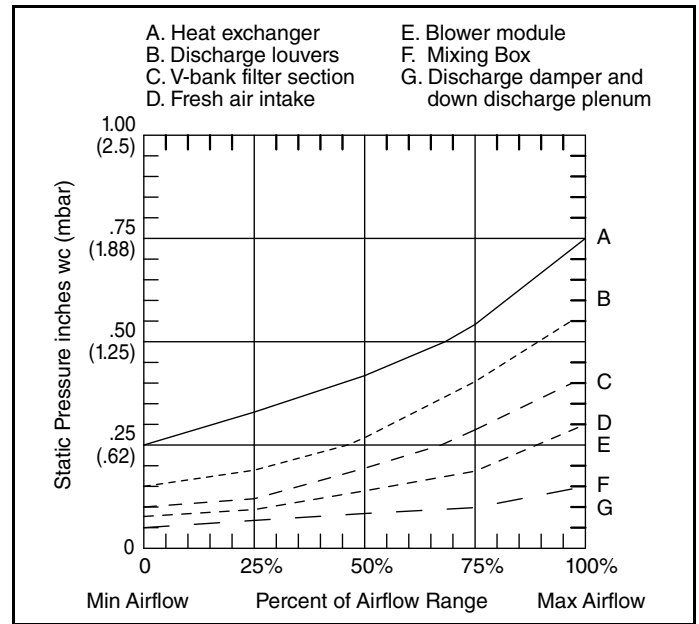

Table 12: Blower Motor Horsepower Selection (Includes Drive Losses)

Models 35/45	Total Static Pressure		.50 in wc / 1.25 mbar		.75 in wc / 1.87 mbar		1.00 in wc / 2.49 mbar		1.25 in wc / 3.11 mbar		1.50 in wc / 3.74 mbar		1.75 in wc / 4.36 mbar		2.00 in wc / 4.98 mbar		2.25 in wc / 5.6 mbar		2.50 in wc / 6.23 mbar	
	AIRFLOW		RPM	BHP	RPM	BHP	RPM	BHP	RPM	BHP	RPM	BHP	RPM	BHP	RPM	BHP	RPM	BHP	RPM	BHP
	CFM	m³/h																		
3,500	5,947	528	.062	623	.081	708	0.99	786	1.19	860	1.40									
4,000	6,796	548	.082	637	1.00	720	1.22	793	1.43	863	1.66	928	1.89	993	2.14					
4,500	7,646	574	1.07	654	1.27	732	1.49	805	1.73	872	1.96	935	2.22	995	2.47	1,053	2.73	1,110	3.00	
5,000	8,495	607	1.37	675	1.57	748	1.80	819	2.00	884	2.32	945	2.58	1,003	2.86	1,058	3.13	1,112	3.42	
5,500	9,345	645	1.74	703	1.94	767	2.18	833	2.45	897	2.73	957	3.00	1,014	3.30	1,068	3.60	1,119	3.90	
6,000	10,194	686	2.18	734	2.38	791	2.62	851	2.90	913	3.20	971	3.50	1,027	3.81	1,079	4.13	1,130	4.44	

Models 200/225/250/275/300	Total Static Pressure		.50 in wc / 1.25 mbar		.75 in wc / 1.87 mbar		1.00 in wc / 2.49 mbar		1.25 in wc / 3.11 mbar		1.50 in wc / 3.74 mbar		1.75 in wc / 4.36 mbar		2.00 in wc / 4.98 mbar		2.25 in wc 5.6 mbar		2.50 in wc 6.23 mbar	
	AIRFLOW CFM m ³ /h		RPM	BHP	RPM	BHP	RPM	BHP	RPM	BHP	RPM	BHP	RPM	BHP	RPM	BHP	RPM	BHP	RPM	BHP
	21,000	35,679	309	3.52	362	4.58	411	5.76												
23,000	39,077	318	4.19	368	5.22	415	6.42	460	7.92											
25,000	42,475	327	4.94	376	6.16	420	7.46	463	8.84	503	10.32									
27,000	45,873	338	5.79	384	7.09	426	8.45	467	9.89	506	11.39	544	12.98	580	14.66					
29,000	49,271			392	8.13	434	9.56	473	10.97	511	12.55	546	14.24	581	15.93	616	17.72			
31,000	52,669			402	9.31	442	10.76	480	12.34	516	13.93	551	15.61	584	17.41	617	19.20	650	21.10	
33,000	56,067			413	10.55	452	12.13	487	13.72	522	15.40	556	17.20	588	20.68	624	20.89	654	22.79	
35,000	59,465					461	13.61	496	15.30	530	17.09	593	18.88	593	20.68	624	20.89	654	22.79	
37,000	62,863					471	15.30	505	17.09	538	18.88	599	20.68	599	22.58	629	24.58	658	26.50	
39,000	66,261					481	17.09	515	18.99	546	20.78	606	22.79	606	24.69	635	26.69	663	28.80	
41,000	69,659							524	20.99	555	23.00	614	24.90	614	27.01	641	29.01	669	31.23	
43,000	73,057									565	25.21	622	27.32	622	29.43	649	31.54	675	33.76	
45,000	76,455									575	27.75	631	29.86	631	32.07	657	34.29	683	36.50	

Models 350/400/450	Total Static Pressure		.50 in wc / 1.25 mbar		.75 in wc / 1.87 mbar		1.00 in wc / 2.49 mbar		1.25 in wc / 3.11 mbar		1.50 in wc / 3.74 mbar		1.75 in wc / 4.36 mbar		2.00 in wc / 4.98 mbar		2.25 in wc 5.6 mbar		2.50 in wc 6.23 mbar	
	AIRFLOW CFM m ³ /h		RPM	BHP	RPM	BHP	RPM	BHP	RPM	BHP	RPM	BHP	RPM	BHP	RPM	BHP	RPM	BHP	RPM	BHP
	35,000	59,465	265	6.54	306	8.19	344	9.93	380	11.82	415	13.82								
36,000	61,164	267	6.93	307	8.61	345	10.38	381	12.24	415	14.24									
37,000	62,863	270	7.33	310	9.04	347	10.85	382	12.77	416	14.77									
38,000	64,562	273	7.75	312	9.51	348	11.33	383	13.19	416	15.30	448	17.51							
39,000	66,261	276	8.20	314	9.98	350	11.82	384	13.72	417	15.83	448	18.04							
40,000	67,960	279	8.65	317	10.49	352	12.38	385	14.35	418	16.46	448	18.04							
41,000	69,659	282	9.13	320	10.97	354	12.92	387	14.88	419	16.99	449	19.31							
42,000	71,538	285	9.62	322	11.50	357	13.40	388	15.51	420	17.62	450	19.94	479	22.26	507	24.79			
43,000	73,057			325	12.03	359	14.09	390	16.14	421	18.25	450	20.57	480	22.99	509	25.54			
44,000	74,756			327	12.66	361	14.71	392	16.77	423	18.99	452	21.31	480	23.63	509	26.16			
45,000	76,455			330	13.19	363	15.30	395	17.48	424	19.62	453	21.94	481	24.37	509	26.90	536	29.64	
46,000	78,154			333	13.83	365	16.01	397	18.18	426	20.36	455	22.68	482	25.21	510	27.75	536	30.38	
47,000	79,854			335	14.45	368	16.70	399	18.89	427	21.10	456	23.53	483	25.95	510	28.49	536	31.23	
48,000	81,553			339	15.19	370	17.41	401	19.62	429	21.94	457	24.27	484	26.80	511	29.33	537	32.07	
49,000	83,252					373	18.14	403	20.36	431	22.74	459	25.11	485	27.64	512	30.27	537	32.92	
50,000	84,951					376	18.90	405	21.21	434	23.56	460	25.95	486	28.49	513	31.45	538	33.87	
51,000	86,650					379	19.62	407	21.94	436	24.41	462	26.80	488	29.43	514	32.07	539	34.82	
52,000	88,349					381	20.48	410	22.79	438	25.21	464	27.75	490	30.27	515	33.02	540	35.76	
53,000	90,048					384	21.31	413	23.63	440	26.16	466	28.73	492	31.23	516	33.97	541	36.71	
54,000	91,747					387	22.37	415	24.58	442	27.11	468	29.69	493	32.28	518	35.03	542	37.77	
55,000	93,446					390	23.04	418	25.53	444	28.06	471	30.68	494	33.38	519	36.07	543	38.82	
56,000	95,145							421	26.48	447	29.01	473	31.65	497	34.29	521	37.14	544	39.98	
57,000	96,844							423	27.43	449	30.07	475	32.71	499	35.47	522	38.19	545	41.04	

Table 13: Sound Data

		Octave Band Noise (Hz)	Model							
			35/45	50/65	75/85/100	125	150/175	200/225	250/275/300	350/400/450
Sound Pressure Levels	From Free-Standing Blower at 6 ft (1.8 m) (dBA)	63	72	77	75	77	89	88	89	79
		125	79	81	82	76	82	84	85	74
		250	73	76	76	71	74	78	78	77
		500	70	71	73	69	74	75	76	74
		1000	65	66	68	66	68	74	74	78
		2000	62	66	65	62	65	71	71	71
		4000	58	63	61	58	59	65	66	69
	8000	52	59	55	55	56	60	61	70	
		From Ducted Inlet or Ducted Outlet Blower at 5 ft. (1.5 m) (dBA)	76	79	79	75	79	83	83	85
		From Ducted Inlet and Ducted Outlet Blower at 5 ft. (1.5 m) (dBA)	56	59	59	55	59	63	63	65
	From Duct Inlet and Duct Outlet Air Handler with Burner at 5 ft. (1.5 m)* (dBA)	76	76	77	79	79	84	87	87	
Sound Power Levels	From Blower of Free-Standing Air Handler (dBA)	87	90	90	86	90	94	94	96	

* Deduct 2 dBA (35-175) / 3 dBA (200-400) for air handlers that have a weather enclosure around the burner and manifold assemblies. (The weather enclosure is included as standard in the weatherizing package required for all air handlers installed outside.)

NOTE: This data assumes the air handler is designed to operate at the maximum allowable airflow for that particular model and at 2" ESP. Noise level data can vary widely dependant on the installation surroundings of the air handler. Data is to be used as a guideline only and applies to horizontal and upright air handlers in any configuration.

SECTION 6: LIFTING AN AIR HANDLER

⚠ WARNING

Crush Hazard
Use proper lifting equipment and practices.
Failure to follow these instructions can result in death, injury or property damage.

The air handler must be installed in compliance with all applicable codes. The qualified installer or service technician must use best building practices when installing the air handler and any optional equipment. Before installation, check local distribution condition, nature of fuel and fuel pressure, and the current state of adjustment of the appliance are compatible. If filters are not installed via filter section or bird screen via inlet hood, an air strainer (provided by others) must be installed on the inlet of the air handler with openings not greater than 5/8" (16 mm) in diameter. Air inlets must be installed in such a manner that their lowest edge is 16" (406.4 mm) above any surface. This applies to roof curbs, upright stands and suspended air handlers.

6.1 Lifting an Air Handler**6.1.1 Preparing to Lift the Air Handler:**

Prior to lifting the air handler, the following steps must be performed.

1. Remove all packaging or banding that attached the air handler to the skid and ensure that the air handler is no longer bound to the skid.
2. Remove all packaging or blockers.
3. Remove all of the accessories or packages that were shipped on the same skid, inside the air handler or inside the control enclosure.
4. Inspect the air handler to:
 - Verify that there is no damage as a result of shipping.
 - Ensure that it is appropriately rated for the utilities available at the installation site.
 - Verify that the lifting lugs are intact, undamaged and secured to the air handler.
 - Ensure factory-installed hardware is torqued as specified.

5. Prepare the installation location to be ready to accept the air handler (i.e. roof curb or mounting stand).
6. Verify that the lifting equipment can handle the air handler's weight and the required reach.

6.1.2 Lifting a Horizontal Air Handler

Lift the air handler into place installing appropriate hardware (supplied by others) into all four 0.75" (1.9 cm) diameter lifting lugs holes. Use spreader bars to ensure that the lifting cables clear the sides of the air handler. See Page 26, Figure 18. Use caution as the load may be unbalanced. The air handler must be kept level during the lift to prevent tipping, twisting or falling. If lifted improperly, product damage may occur.

If the air handler is shipped as two pieces, lift the two pieces separately and then assemble. See Page 27, Section 7 for assembly instructions. Refer to the applicable portions of Page 41, Section 9 through Page 45, Section 10 for assembly and mounting instructions for specific accessories.

6.1.3 Lifting an Upright Air Handler

Lift the air handler into place installing appropriate hardware (supplied by others) into all four 0.75" (1.9 cm) diameter lifting lugs holes. Use spreader bars to ensure that the lifting cables clear the sides of the air handler. See Page 26, Figure 19. Use caution as the load may be unbalanced. The air handler must be kept level during the lift to prevent tipping, twisting or falling. If lifted improperly, product damage may occur.

If the air handler is shipped as two pieces, lift the two pieces separately and then assemble. See Page 27, Section 7 for assembly instructions. Refer to the applicable portions of Page 41, Section 9 through Page 45, Section 10 for assembly and mounting instructions for specific accessories.

FIGURE 18: Lifting a Horizontal Air Handler

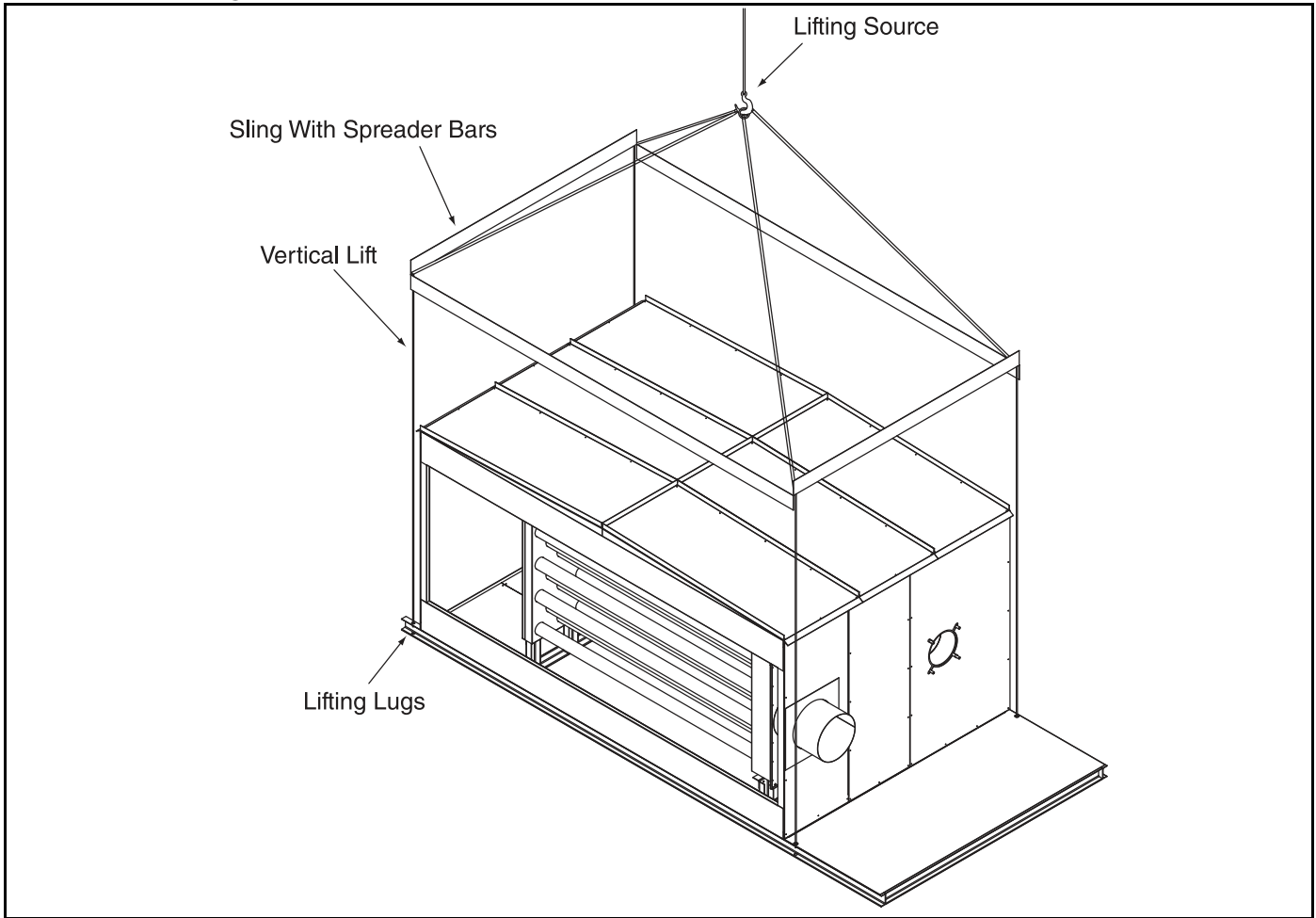
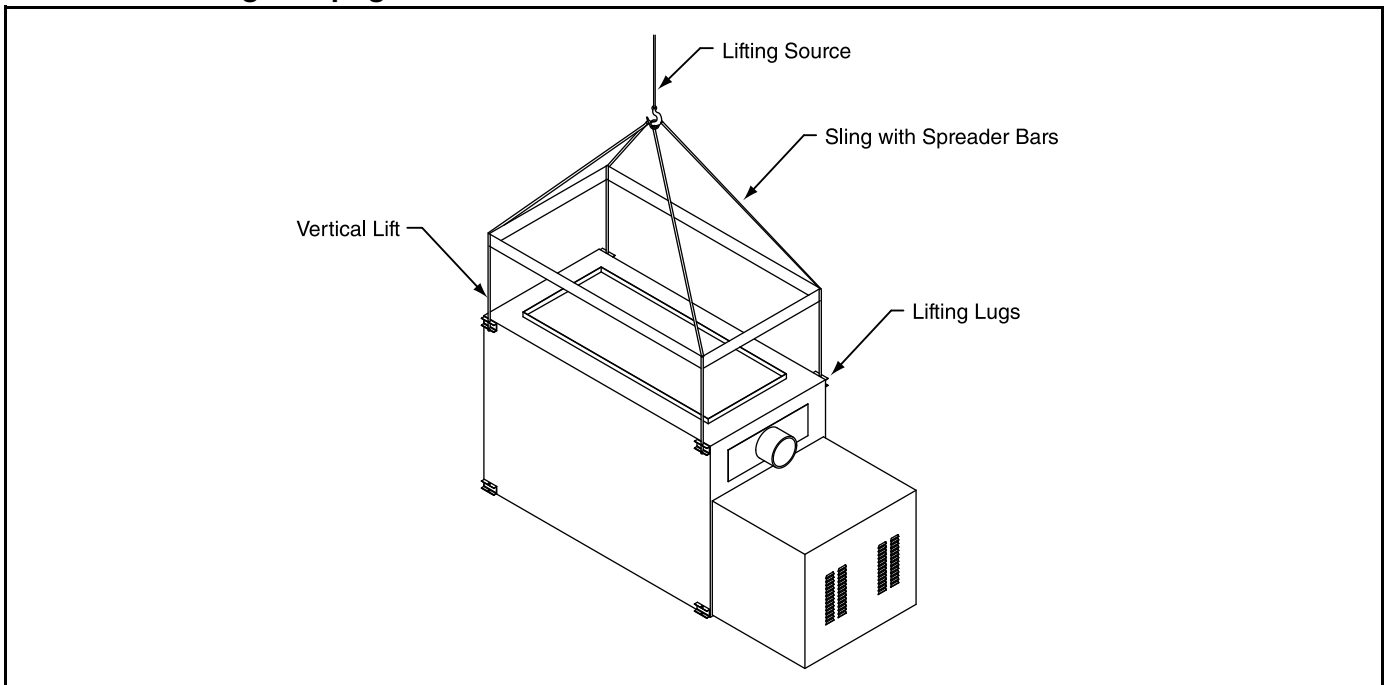

FIGURE 19: Lifting an Upright Air Handler



SECTION 7: AIR HANDLER ASSEMBLY

⚠ WARNING			
			
Crush Hazard Use proper lifting equipment and practices.	Falling Hazard Use proper safety equipment and practices to avoid falling.	Severe Injury Hazard Use proper lifting practices and equipment. Equipment and accessories are heavy.	Cut/Pinch Hazard Wear protective gear during installation, operation and service. Edges are sharp.
Failure to follow these instructions can result in death, injury or property damage.			

For models 35 - 125, the burner and blower sections of the air handler are shipped as one piece. No field assembly is required.

For models 150 - 450, the burner and blower sections of the air handler are shipped as two pieces that require field-assembly. To assemble, use the supplied hardware and bolt the blower section to the burner section through pre-drilled holes. Supplied hardware must be torqued to recommended specifications on Page 13, Table 1.

For details, See Page 28, Figure 20.

Caulk (provided by others) the sides, roof and bottom seams between the blower section and burner section. Once caulk has been applied (See Page 28, Figure 20), the provided roof seam cover should be drill screwed over the caulked seam every 12" (30.5 cm) with the provided drill screws. See Page 27, Table 14 for quantity of screws required.

Table 14: Roof Seam Cover Drill Screws

Model	Quantity of Drill Screws per Section for Seam Cover
35/45	5
50/65/75	6
85/100	6
125	8
150/175	9
200/225	10
250/300	10
350/450	14

FIGURE 20: Air Handler Assembly - Horizontal (Models 150 - 450)

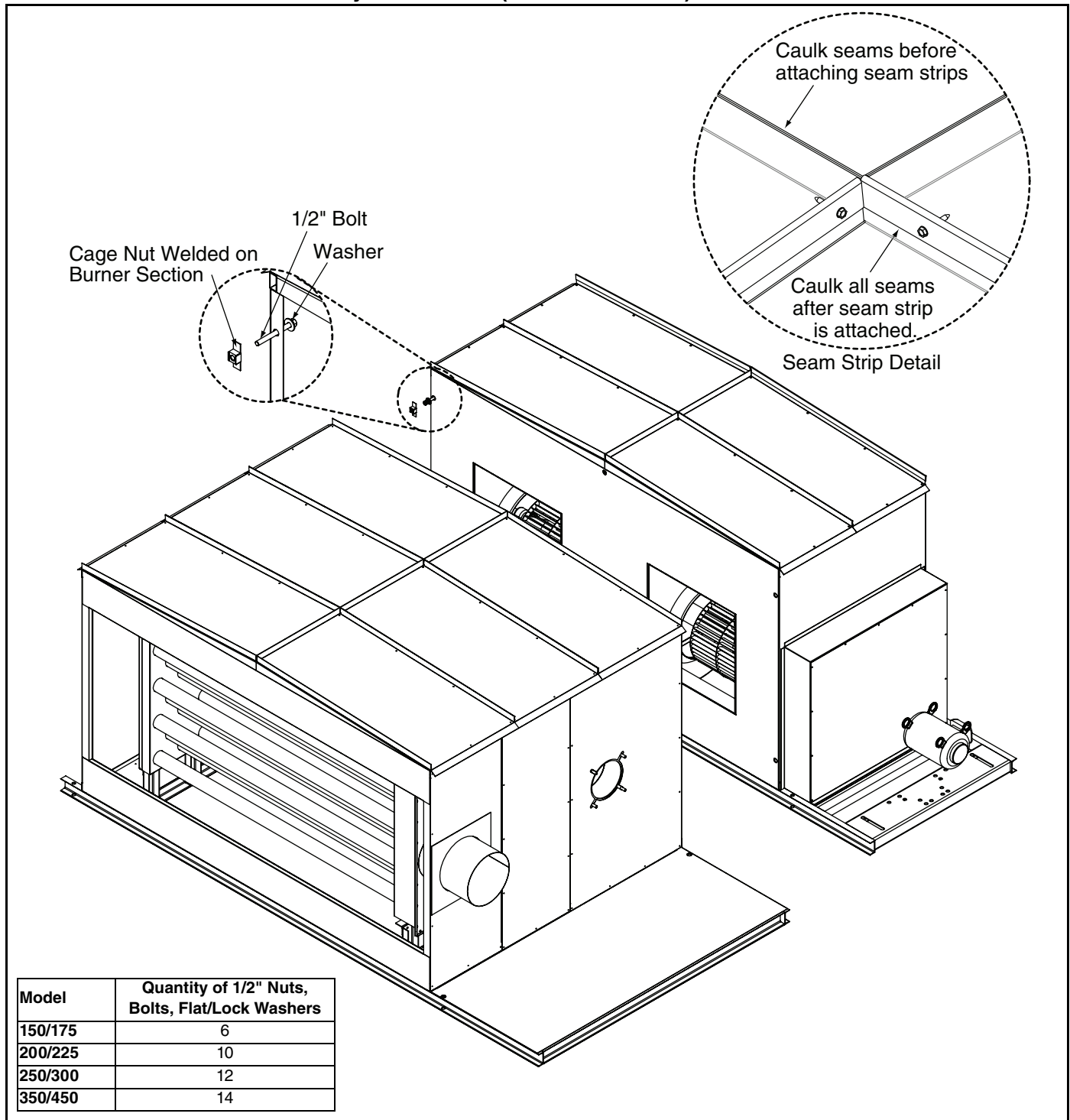
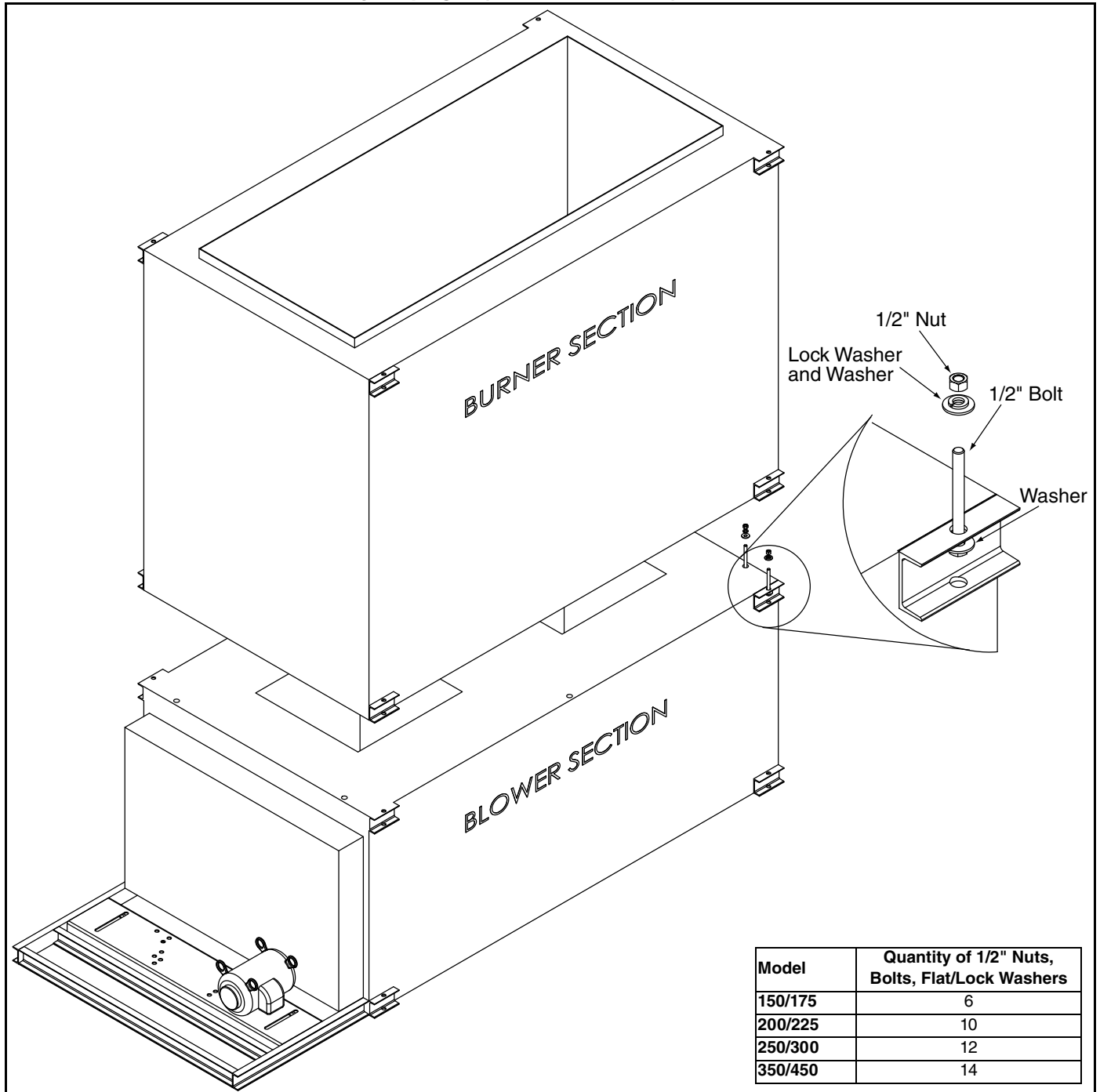

FIGURE 21: Air Handler Assembly - Upright (Models 150 - 450)

SECTION 8: VIBRATION ISOLATORS

⚠ WARNING			
			
Crush Hazard Use proper lifting equipment and practices.	Falling Hazard Use proper safety equipment and practices to avoid falling.	Severe Injury Hazard Use proper lifting practices and equipment. Equipment and accessories are heavy.	Cut/Pinch Hazard Wear protective gear during installation, operation and service. Edges are sharp.
Failure to follow these instructions can result in death, injury or property damage.			

There are five types of vibration isolators available - waffle pad isolators for curb-mounted units, neoprene pad isolators for pad-mounted units, neoprene pad isolators for hanger-mounted units, spring isolators for hanger-mounted units and spring isolators for pad-mounted units.

8.1 Waffle Pad Isolator

The waffle pad is 2" (5.1 cm) wide by 15" (38.1 cm) long (See Page 30, Figure 22). This is a resilient cross ribbed neoprene pad with a high deflection rate. Alternately raised ribs provide effective isolation in both high and low load ranges. The application for these strips is for isolating the equipment when it is placed on top of the standard factory-supplied curb.

FIGURE 22: Waffle Pad Isolator

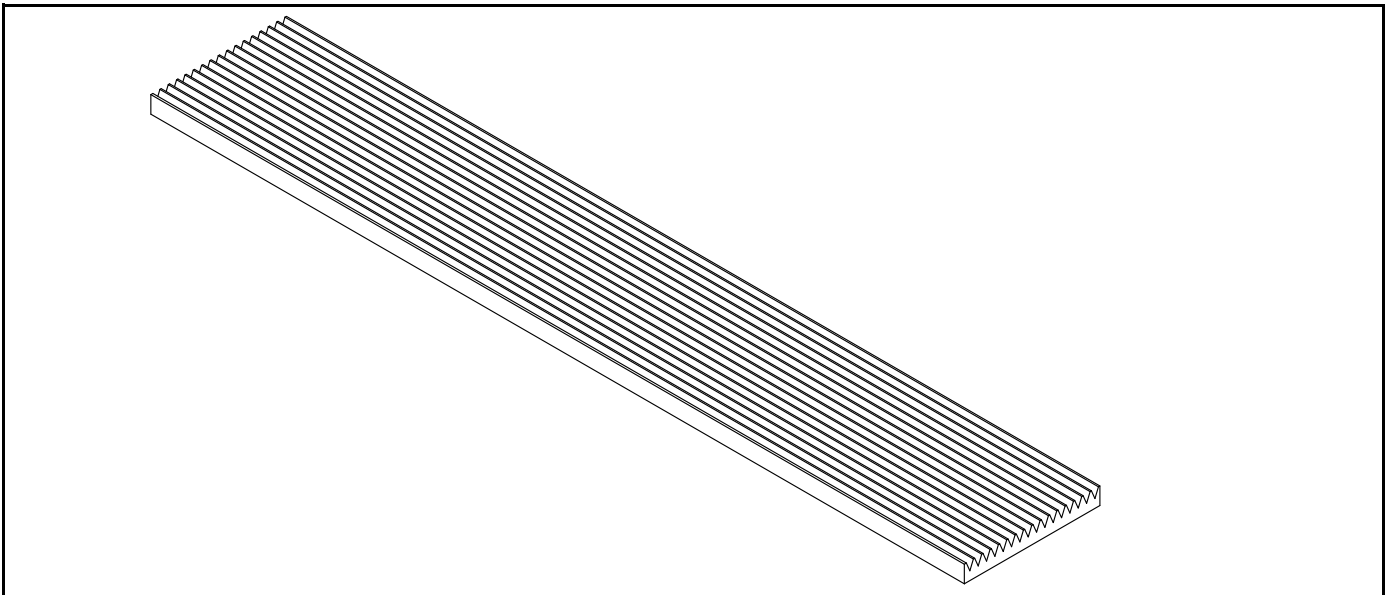

8.1.1 Installation Instructions for Waffle Pad Isolator

1. Lay strips on the top surface of the curb. See Page 31, Figure 23.
2. Hold them in place with tape, such as masking or duct tape.
3. Trim as needed to cover the perimeter of the curb.
4. Lift and place the air handler on top of curb.

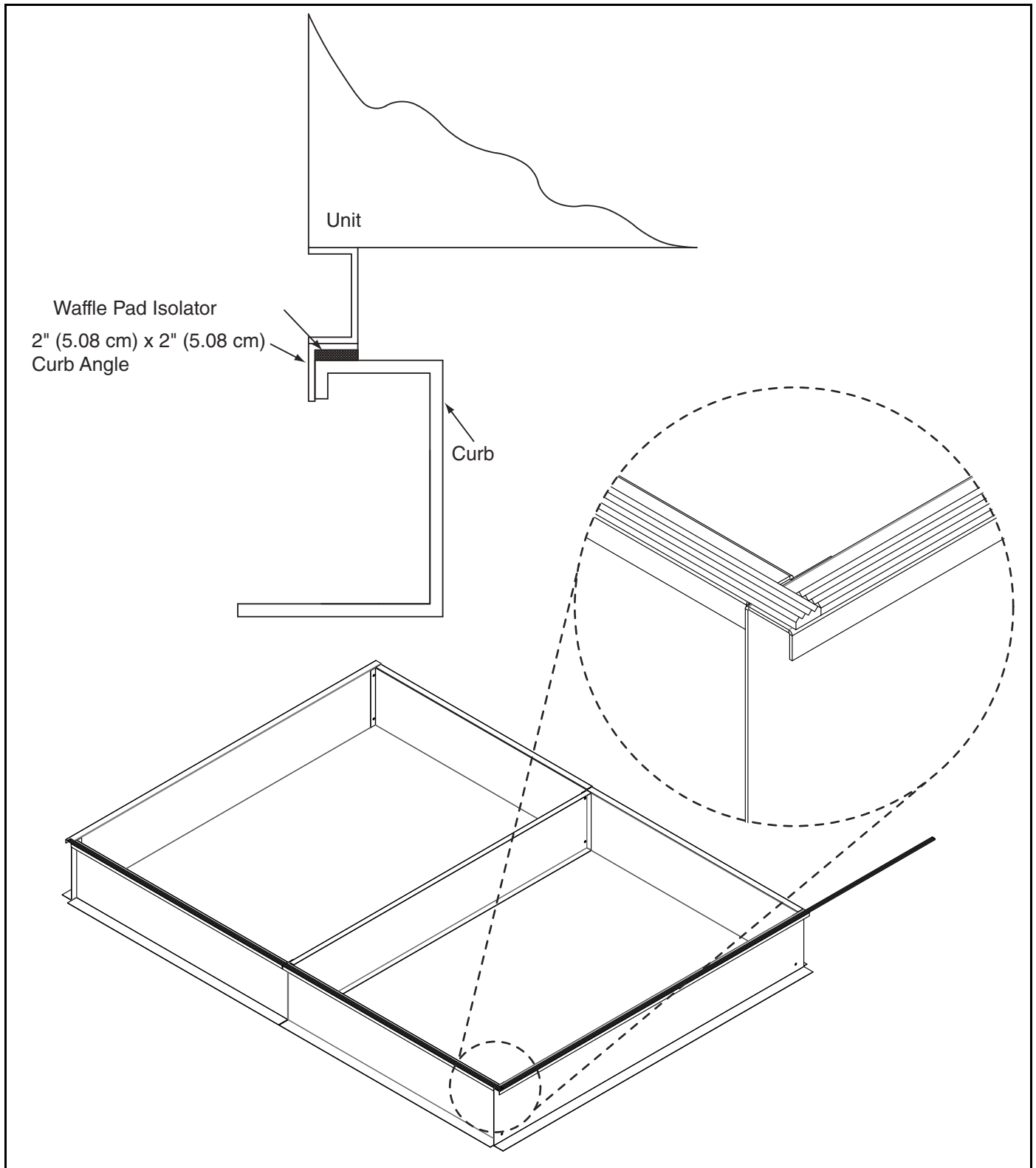
FIGURE 23: Pad Isolator Installation Instructions

8.2 Neoprene or Spring Isolators for Hanger-Mounted Units

The hanger style isolator, which is available in either a neoprene version or spring version, is used to suspend the air handler from any overhead support.

It is supplied with a rectangular steel housing which incorporates the neoprene element or spring. See *Page 32, Figure 24*. The design permits either the housing to be bolted directly to the ceiling or support structure or be suspended from hanger rods (which are sized and supplied by the installer along with all

hardware). Neoprene style is normally selected when noise is also a consideration besides vibration. The spring style is normally selected when the concern is strictly vibration.

FIGURE 24: Hanging Isolators

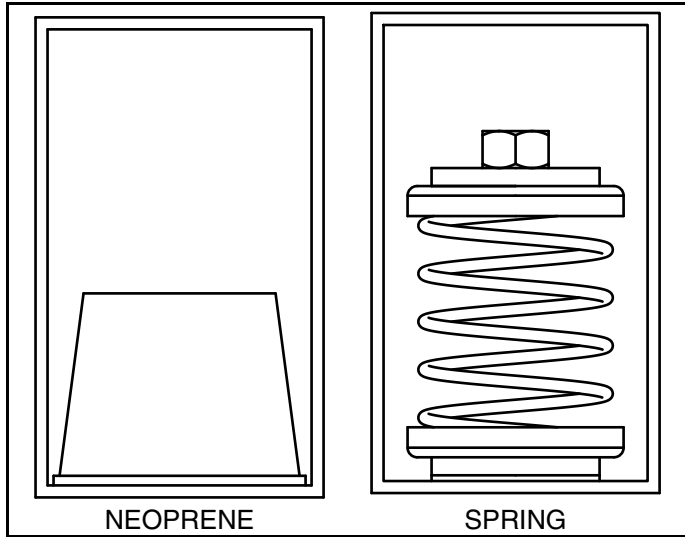

8.2.1 Installation Instructions for Neoprene or Spring Isolators for Hanger-Mounted Units

All hardware, which includes nuts, washers and hanger rods are to be supplied by the installer.

1. Equipment should be hung at its proper elevation by using temporary fixtures that can be removed after vibration isolators are installed and adjusted.
2. Isolators may be fastened directly to the structure or inserted in the hanger rods. (See Page 32, Figure 25) For best results, isolators should be located at or near the ceiling.
3. Install isolators.
4. Turn nut on lower rod assembly clockwise one complete turn on each isolator. Repeat this procedure until temporary hanging fixtures are loose and load of equipment is suspended completely on the vibration isolators. See Page 32, Figure 25.
5. Remove temporary hanger fixtures and level equipment by taking additional turns on the lower isolator rod nut clockwise to raise, counter clockwise to lower as required.

NOTE: It is recommended on models 35 - 125 that the hanger rod pass through the upper support tube and attach to the lower support tube. See Page 33, Figure 26.

It is recommended on models 150 - 450 that the hanger rod pass through the upper and lower flange of the structural base and attach to the lower flange. See Page 34, Figure 27.

FIGURE 25: Hanger Isolators' Installation Instructions

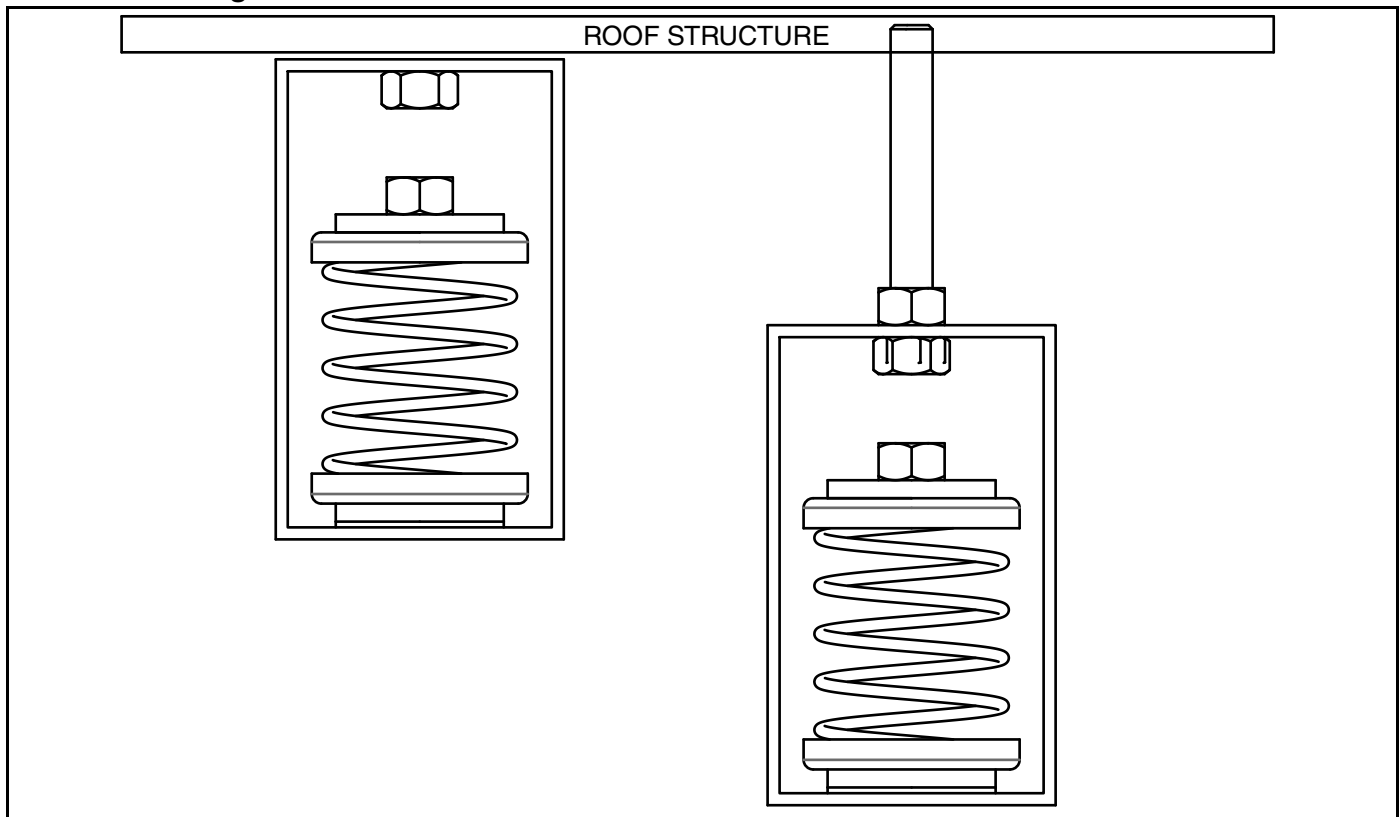

FIGURE 26: Hanging Rods' Installation Instructions (Models 35 - 125)

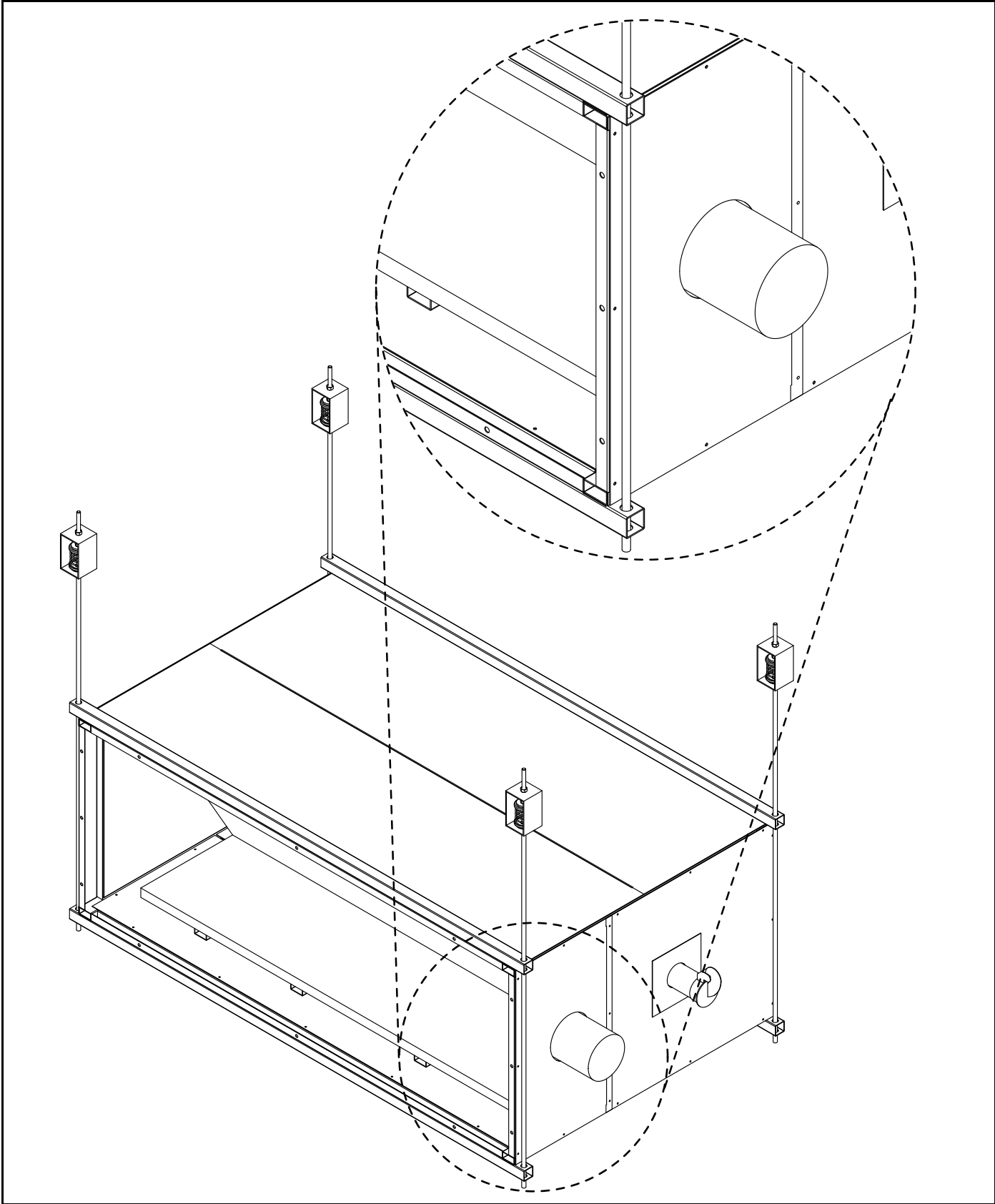
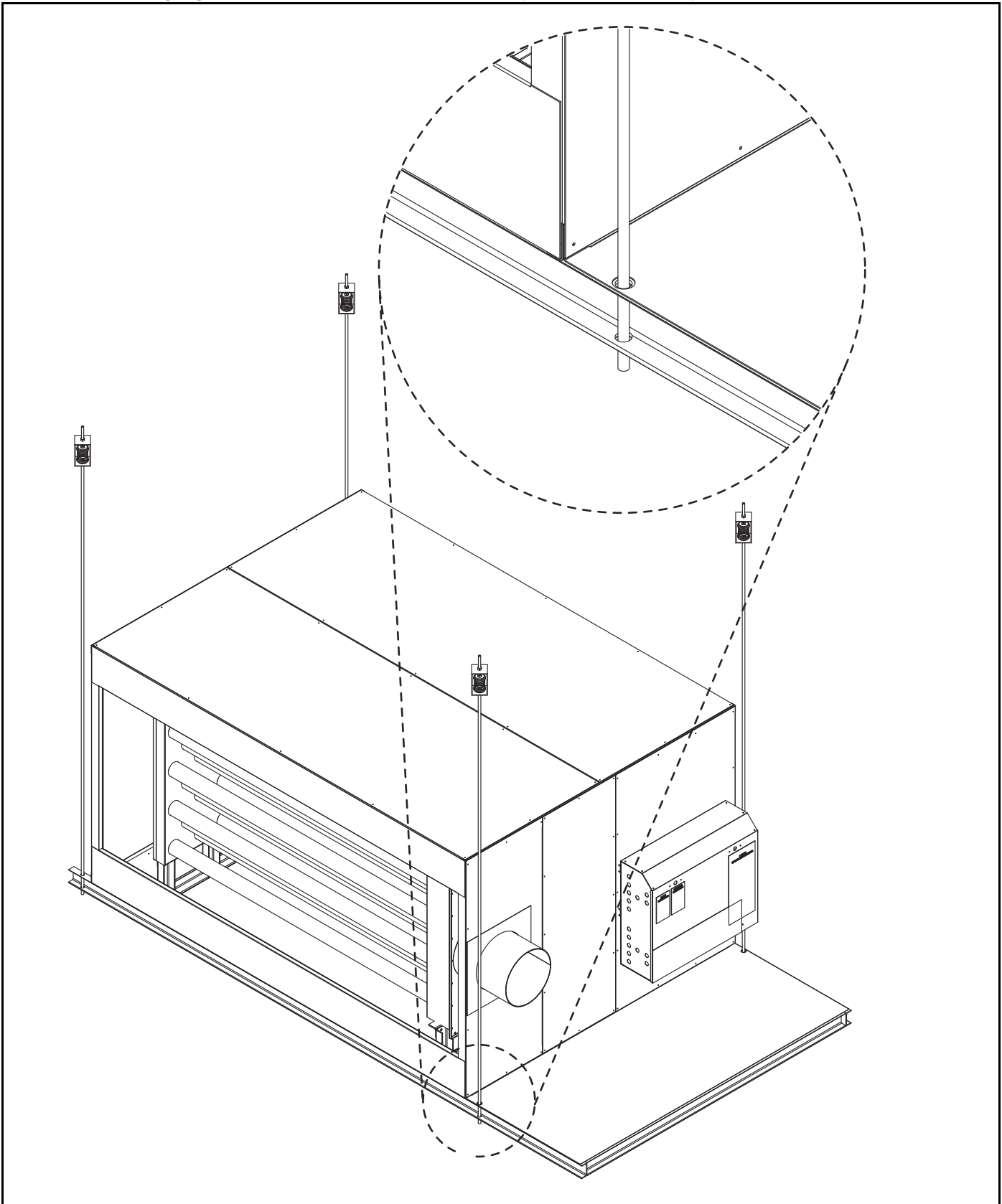

FIGURE 27: Hanging Rods' Installation Instructions (Models 150 - 450)



8.3 Neoprene or Spring Isolators for Pad-Mounted Units

The mount style is available in either a neoprene version or spring. It is used to support and isolate the air handler from a base pad or structural frame.

8.3.1 Neoprene Mount Isolator

The neoprene mount is a single piece unit and design to be bolted directly to the bottom support base of the air handling equipment and the pad or base it rests on (See Page 35, Figure 28). Neoprene style is normally selected when the equipment requires up to ½ inch (12.7 mm) of static deflection.

FIGURE 28: Pad Mounting of Neoprene Isolator

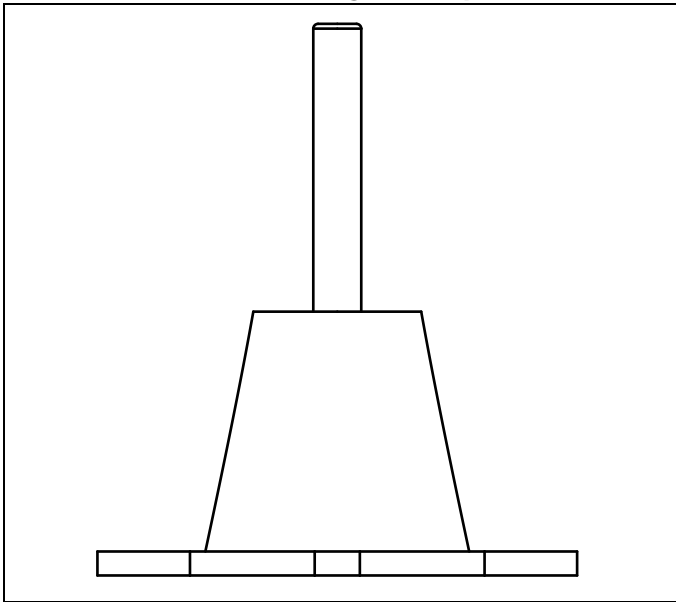

8.3.2 Installation Instructions for Neoprene Mount Isolator

All hardware is to be supplied by the installer.

1. Install blockers under the air handler equipment to allow the isolator to be slid in place.
2. Locate the isolator between the structure and support base of the air handler.
3. Bolt the base of the isolator securely to the structure.
4. Pass a bolt passing through the base of the air handler and screw it into the isolator. See Page 36, Figure 29 through Page 37, Figure 30.

FIGURE 29: Pad Mounting Instructions for Neoprene Isolator (Models 35 - 125)

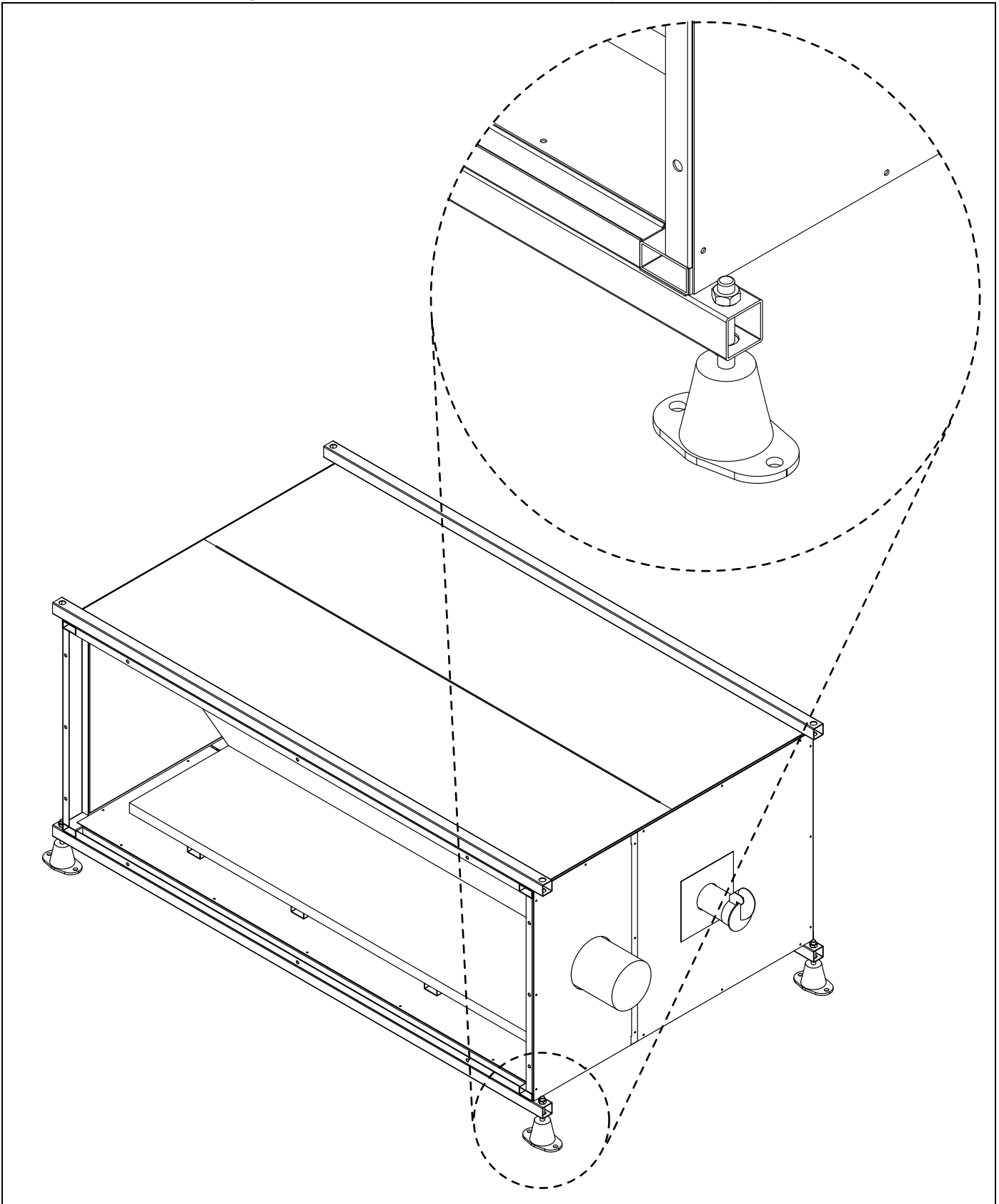
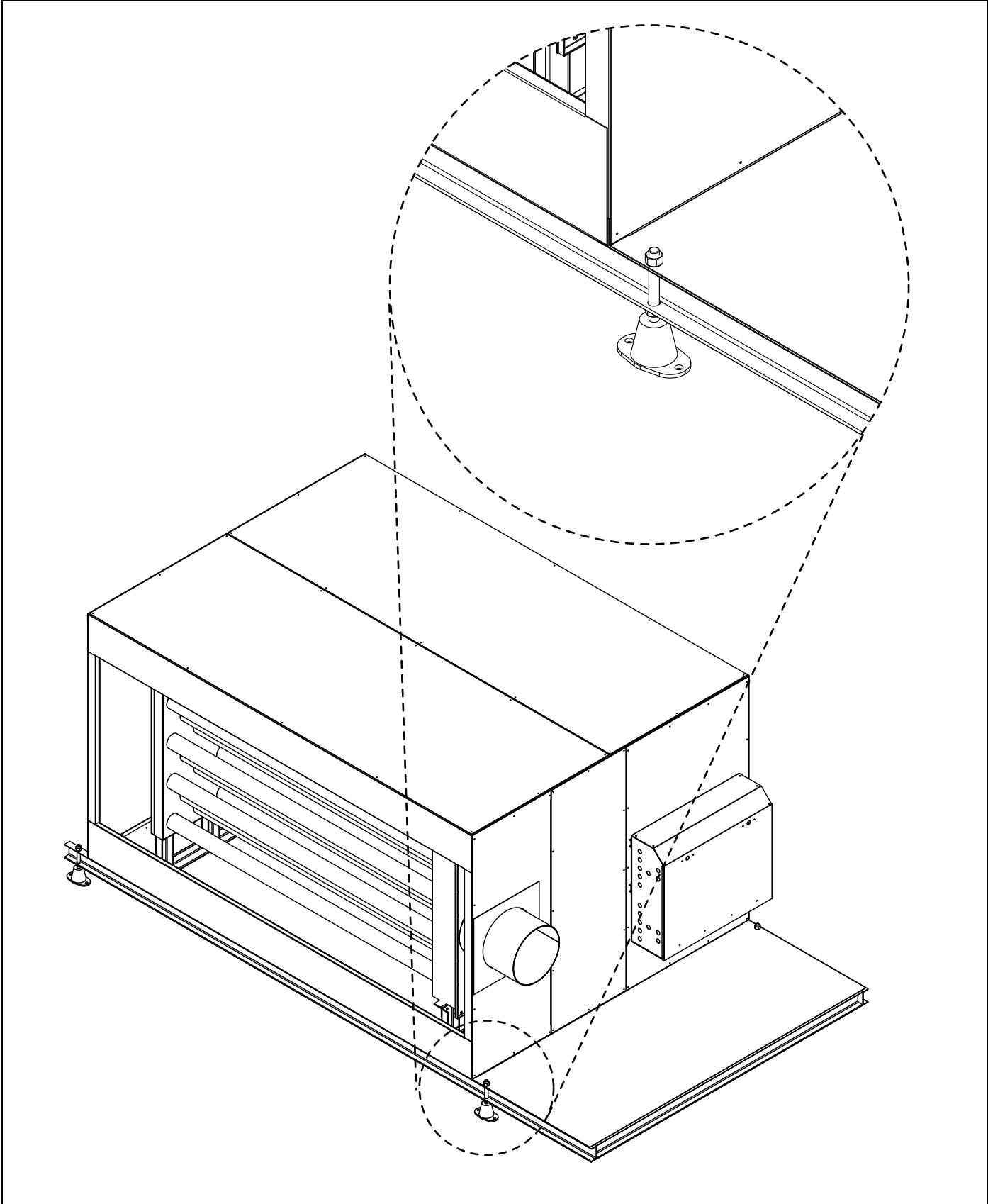

FIGURE 30: Pad Mounting Instructions for Neoprene Isolator (Models 150 - 450)



8.4 Spring Mount Isolator

The spring mount is supplied with a rectangular steel housing which incorporates the spring and load tensioning adjustment bolt. It is equipped with neoprene stabilizers to provide lateral control without binding. Spring style is normally selected when the equipment requires up to 1" (25.4 mm) in deflection. See Page 38, Figure 31.

FIGURE 31: Pad Mounting of Spring Isolator

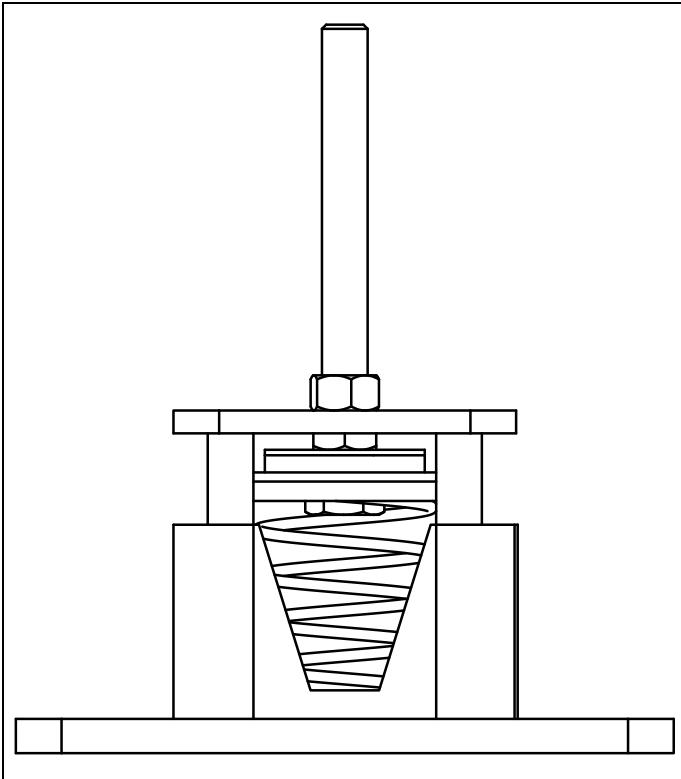

8.4.1 Installation Instructions for Spring Mount Isolator

All hardware required to mount the isolator to the structure is to be supplied by the installer.

1. The spring mount housing serves as the blocking during erection. Locate it between the structure and support base of the air handler.
2. Bolt the base of the isolator securely to the structure.
3. The equipment is held in place by the adjustment bolt passing through the base of the air handler.
4. Adjust the isolator so that the spring pressure plate is a minimum $\frac{1}{4}$ " (6.35 mm) above the lower housing and no more than $\frac{1}{2}$ " (12.7 mm) above the lower housing.

FIGURE 32: Pad Mounting Instructions for Spring Isolator (Models 35 - 125)

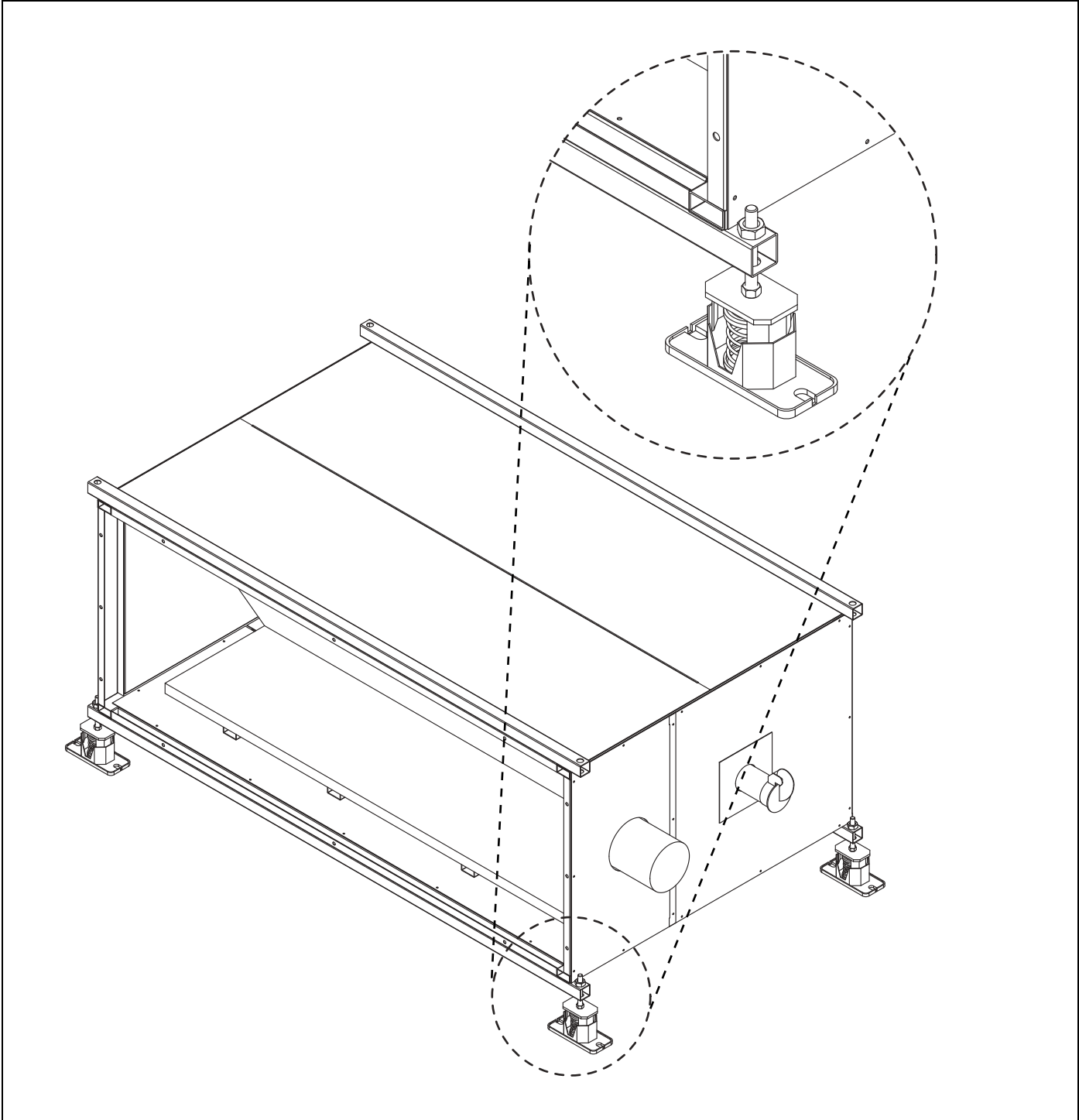
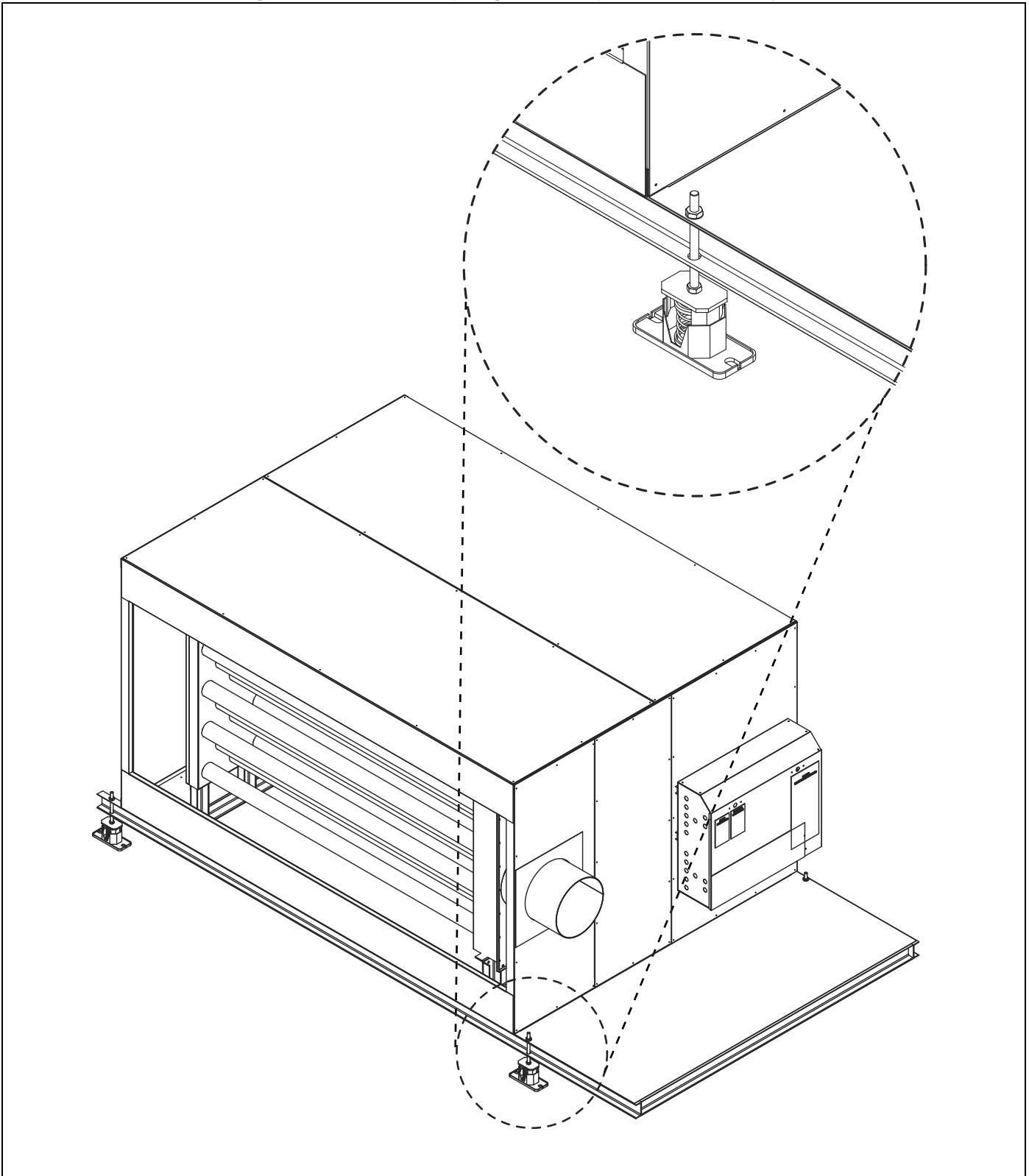

FIGURE 33: Pad Mounting Instructions for Spring Isolator (Models 150 - 450)



SECTION 9: ROOF CURB

⚠ WARNING			
			
Crush Hazard Use proper lifting equipment and practices.	Falling Hazard Use proper safety equipment and practices to avoid falling.	Severe Injury Hazard Use proper lifting practices and equipment. Equipment and accessories are heavy.	Cut/Pinch Hazard Wear protective gear during installation, operation and service. Edges are sharp.
Failure to follow these instructions can result in death, injury or property damage.			

Roof curbs that support the air handler and accessory sections are available for all horizontal air handlers that are to be installed on a typical flat roof (ie. bonded or corrugated). Roof curbs are shipped knocked down and require field assembly. Note: Before installation, verify that you have the correct roof curb and that all required components are present. If any are missing, contact your ROBERTS GORDON® independent representative.

9.1 Roof Curb Assembly and Installation

Assemble roof curb according to the assembly drawing on *Page 42, Figure 34*. Supplied hardware must be torqued to recommended specifications on *Page 13, Table 1*.

Place the curb on the roof in the position in which it will be installed. Check that the diagonal measurements are within 1/8"(3 mm) of each other. To ensure a weatherproof seal between the air handler and the curb, the curb must be level with no twist from end to end. Shim level as required and secure curb to roof deck using best building practices. The curb is self-flashing. Install roofing material as required.

NOTE: Check the installation location to ensure proper clearances to combustibles and clearance for access. See *Page 13, Section 3.1*.

FIGURE 34: Roof Curb

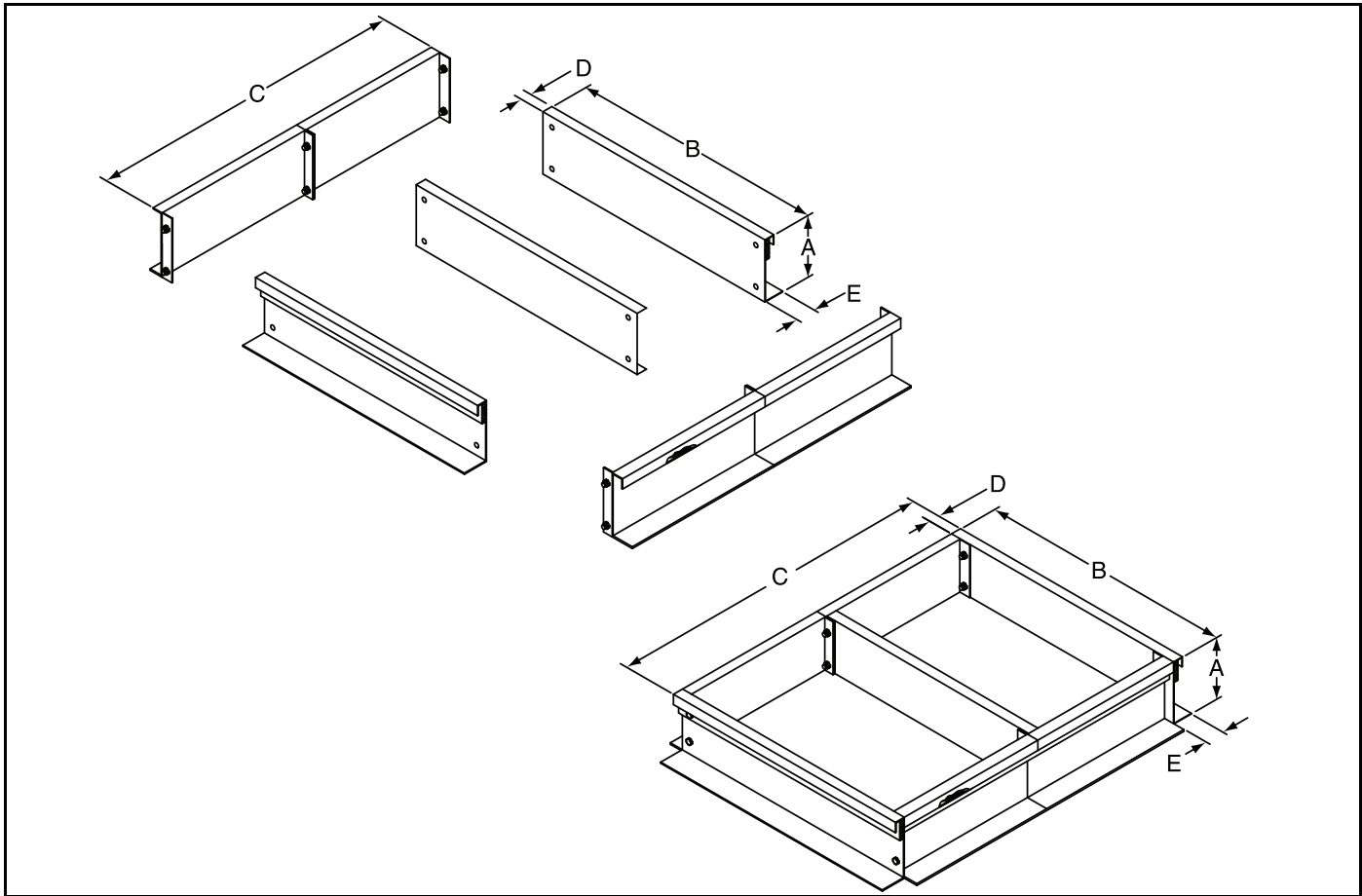

Table 15: Roof Curb Dimensions

Model		A (Height)		B (Width)	C (Length)*			D	E
		16" (40.6 cm) Curb	24" (61.0 cm) Curb		Burner and Blower Sections	Filter Section	Mixing Box Section		
35/45	(in)	16.0	24.0	59.0	89.0	28.0	43.0	1.9	3.0
	(cm)	40.6	61.0	149.8	226.1	71.1	109.2	4.8	7.6
50/60/75	(in)	16.0	24.0	71.0	79.0	28.0	43.0	1.9	3.0
	(cm)	40.6	61.0	180.3	200.7	71.1	109.2	4.8	7.6
85/100	(in)	16.0	24.0	71.0	89.0	24.0	43.0	1.9	3.0
	(cm)	40.6	61.0	180.3	226.1	60.9	109.2	4.8	7.6
125	(in)	16.0	24.0	84.0	101.0	26.0	43.0	1.9	3.0
	(cm)	40.6	61.0	213.4	256.5	66.1	109.2	4.8	7.6
150/175	(in)	16.0	24.0	99.0	113.0	26.0	43.0	1.9	3.0
	(cm)	40.6	61.0	251.4	287.0	66.1	109.2	4.8	7.6
200/225	(in)	16.0	24.0	115.0	126.0	26.0	43.0	1.9	3.0
	(cm)	40.6	61.0	292.1	320.0	66.1	109.2	4.8	7.6
250/275/300	(in)	16.0	24.0	115.0	144.0	26.0	43.0	1.9	3.0
	(cm)	40.6	61.0	292.1	365.8	66.1	109.2	4.8	7.6
350/400/450	(in)	16.0	24.0	159.0	161.0	26.0	43.0	1.9	3.0
	(cm)	40.6	61.0	403.9	408.9	66.1	109.2	4.8	7.6

*To calculate the total length of the roof curb, add together lengths of applicable sections.

Table 16: Roof Curb Weights

Model		16" (40.6 cm) High Curb			24" (61.0 cm) High Curb		
		Burner and Blower Sections	Filter Section	Mixing Box Section	Burner and Blower Sections	Filter Section	Mixing Box Section
35/45	(lb)	200.0	70.0	70.0	266.0	93.1	93.1
	(kg)	90.7	31.8	31.8	120.7	42.2	42.2
50/60/75	(lb)	200.0	70.0	70.0	266.0	93.1	93.1
	(kg)	90.7	31.8	31.8	120.7	42.2	42.2
85/100	(lb)	220.0	75.0	75.0	292.6	99.8	99.8
	(kg)	99.8	34.0	34.0	132.7	45.2	45.2
125	(lb)	300.0	100.0	100.0	399.0	133.0	133.0
	(kg)	136.1	45.4	45.4	181.0	60.3	60.3
150/175	(lb)	350.0	115.0	115.0	465.5	153.0	153.0
	(kg)	158.8	52.2	52.2	211.1	69.4	69.4
200/225	(lb)	375.0	125.0	125.0	498.8	166.3	166.3
	(kg)	170.1	56.7	56.7	226.2	75.4	75.4
250/275/300	(lb)	500.0	165.0	165.0	665.0	219.5	219.5
	(kg)	226.8	74.8	74.8	301.6	99.5	99.5
350/400/450	(lb)	620.0	205.0	205.0	824.6	272.7	272.7
	(kg)	281.2	93.0	93.0	374.0	123.7	123.7

NOTE: *To calculate the total weight of the roof curb, add together weights of applicable sections.

9.2 Air Handler Mounting to Roof Curb

After the curb has been installed, the air handler may be placed on the curb. There must be a 1/8" (.3 cm) x 2" (5.1 cm) neoprene closed cell, adhesive-back gasket (supplied by others) between the top of the curb and the base surface of the air handler to prevent moisture from leaking into the building (ie. from driving rains or melting snow.)

The installer is responsible for tying the air handler to the curb per all applicable codes. See Page 43, Figure 35 through Page 44, Figure 36 for details.

FIGURE 35: Curb Mounting (Models 35 -125)

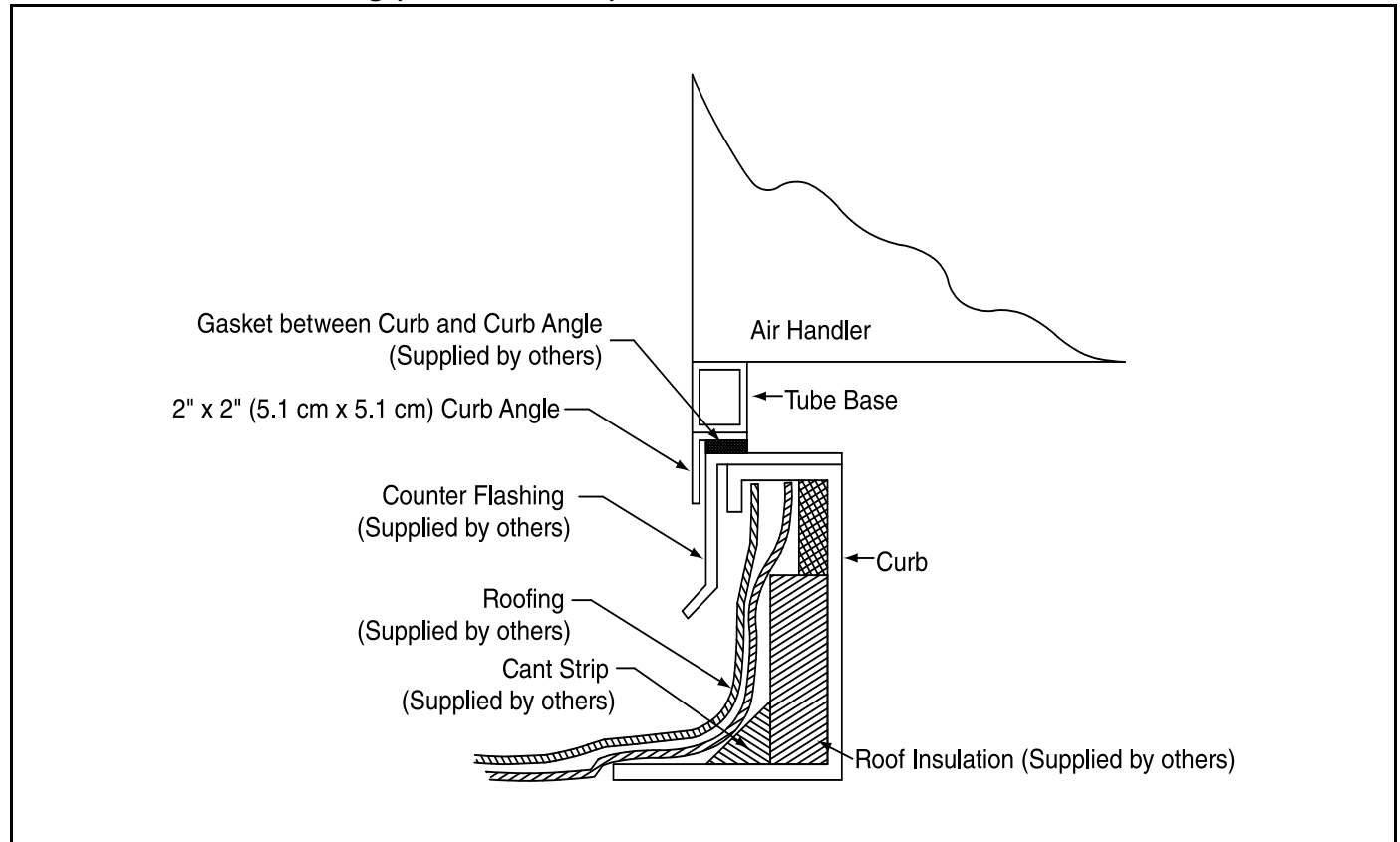
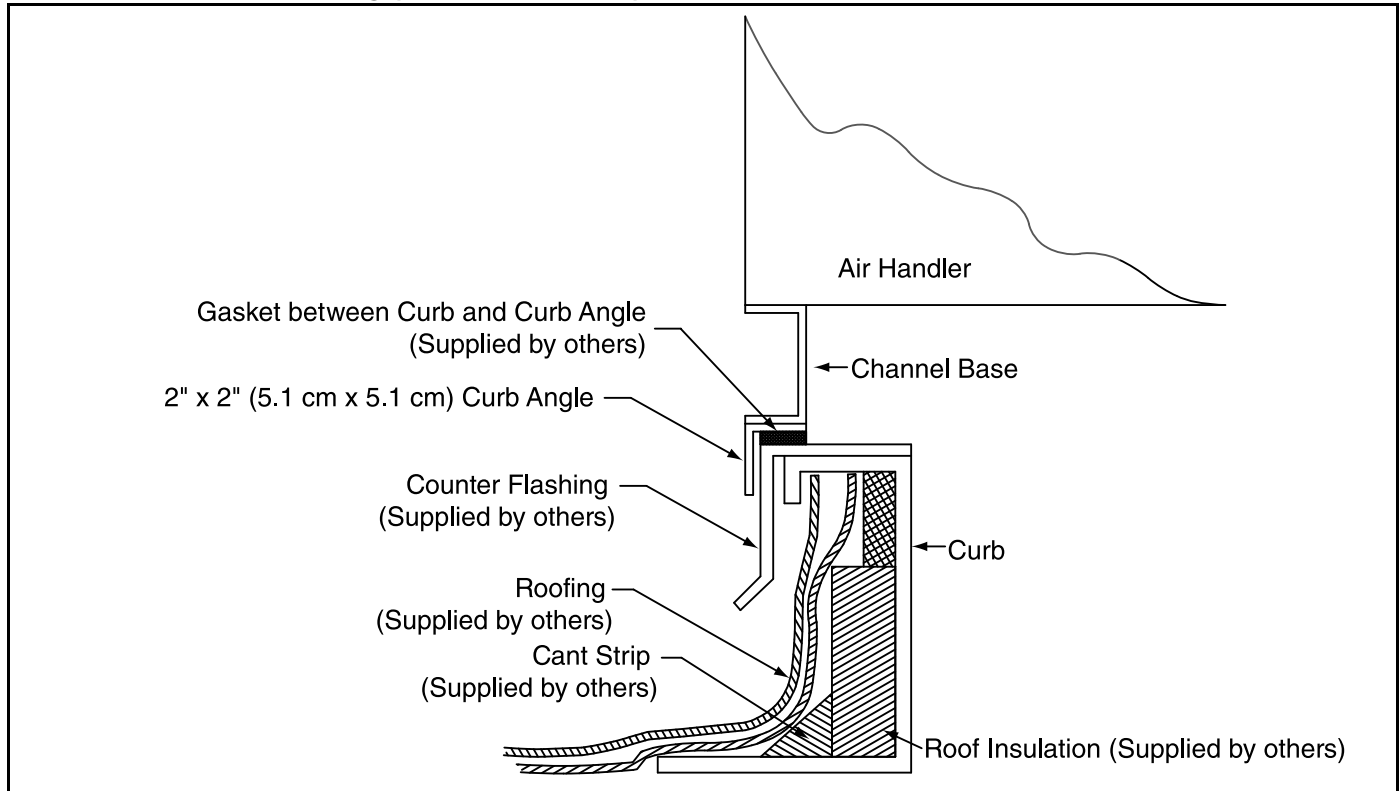

FIGURE 36: Curb Mounting (Models 150 - 450)



SECTION 10: UPRIGHT STAND

⚠ WARNING			
			
Crush Hazard Use proper lifting equipment and practices.	Falling Hazard Use proper safety equipment and practices to avoid falling.	Severe Injury Hazard Use proper lifting practices and equipment. Equipment and accessories are heavy.	Cut/Pinch Hazard Wear protective gear during installation, operation and service. Edges are sharp.
Failure to follow these instructions can result in death, injury or property damage.			

When installing an upright air handler, an upright air handler stand should be used.

For models 35 - 100, See Page 46, Figure 37 for stand dimensions. For models 125 - 450, See Page 46, Figure 38 for stand dimensions.

The stand must first be fastened to the concrete slab or floor before the air handler is mounted.

10.1 Upright Stand Installation

To attach the stand to a concrete slab, it must be secured with the use of studs embedded in the concrete. Four studs must be installed in the slab, one for each corner of the stand. For models 35 -100, the mounting holes are to be field-drilled in the stand pads for installation of the studs. For models 125 - 450, the stand has four 3/4" (19.1 cm) holes drilled through the stand pads. See Page 47, Figure 39. A stud must be installed in the slab for each hole. Fasten the stand to the slab with four hex nuts and lock washers (provided by others).

10.2 Attaching Air Handler to Stand

Once the stand is secured to a concrete slab, the air handler may be placed on the stand. Prior to lifting the air handler, apply a 1/2" (1.27 cm) thick double-sided urethane foam tape (provided by others) to the top edge of the stand. Lift the air handler on to the mounting stand. See Page 25, Section 6.1 for safe lifting practices. Once the air handler is placed on the stand, secure it with the provided hardware per recommended torque settings. See Page 13, Section

3.2. After placing the air handler on the mounting stand, seams between the mounting stand and the air handler must be properly caulked (caulk provided by others).

NOTE: If using the filter section or mixing box section with the upright air handler and stand, the filter section or mixing box must be set down onto the stand before the air handler is mounted on the stand. The 1/2" (1.27 cm) thick double-sided urethane foam tape should be applied between the stand and the filter section or mixing box section.

FIGURE 37: Upright Stand Detail (Models 35 - 100)

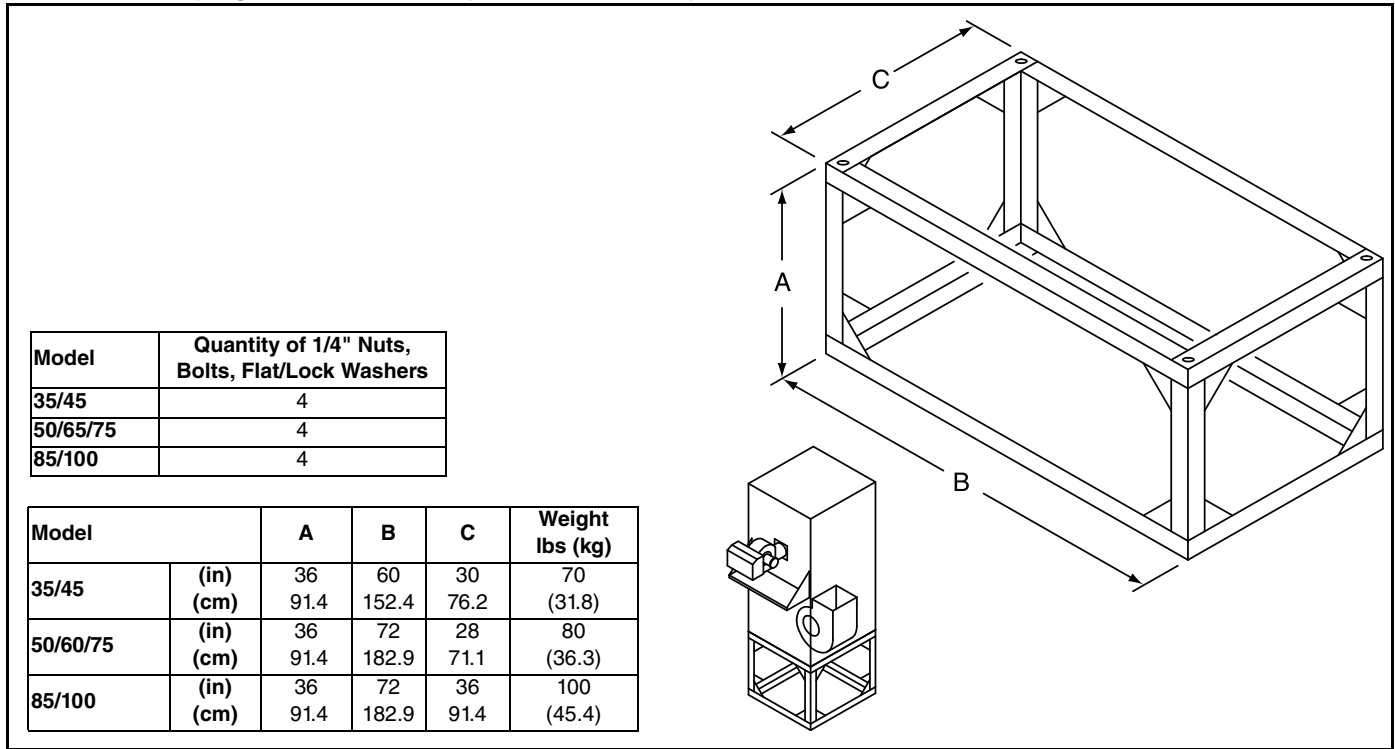

FIGURE 38: Upright Stand Detail (Models 125 - 450)

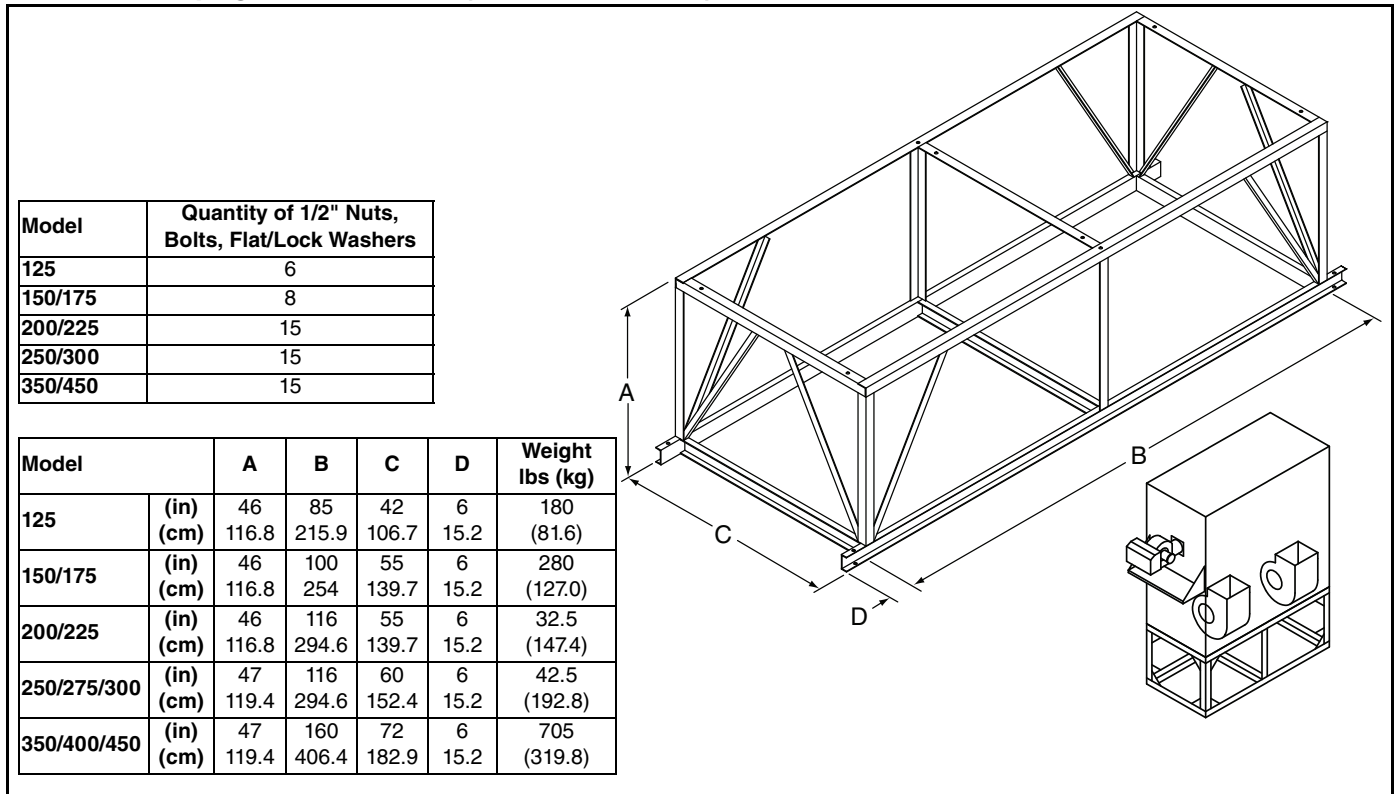
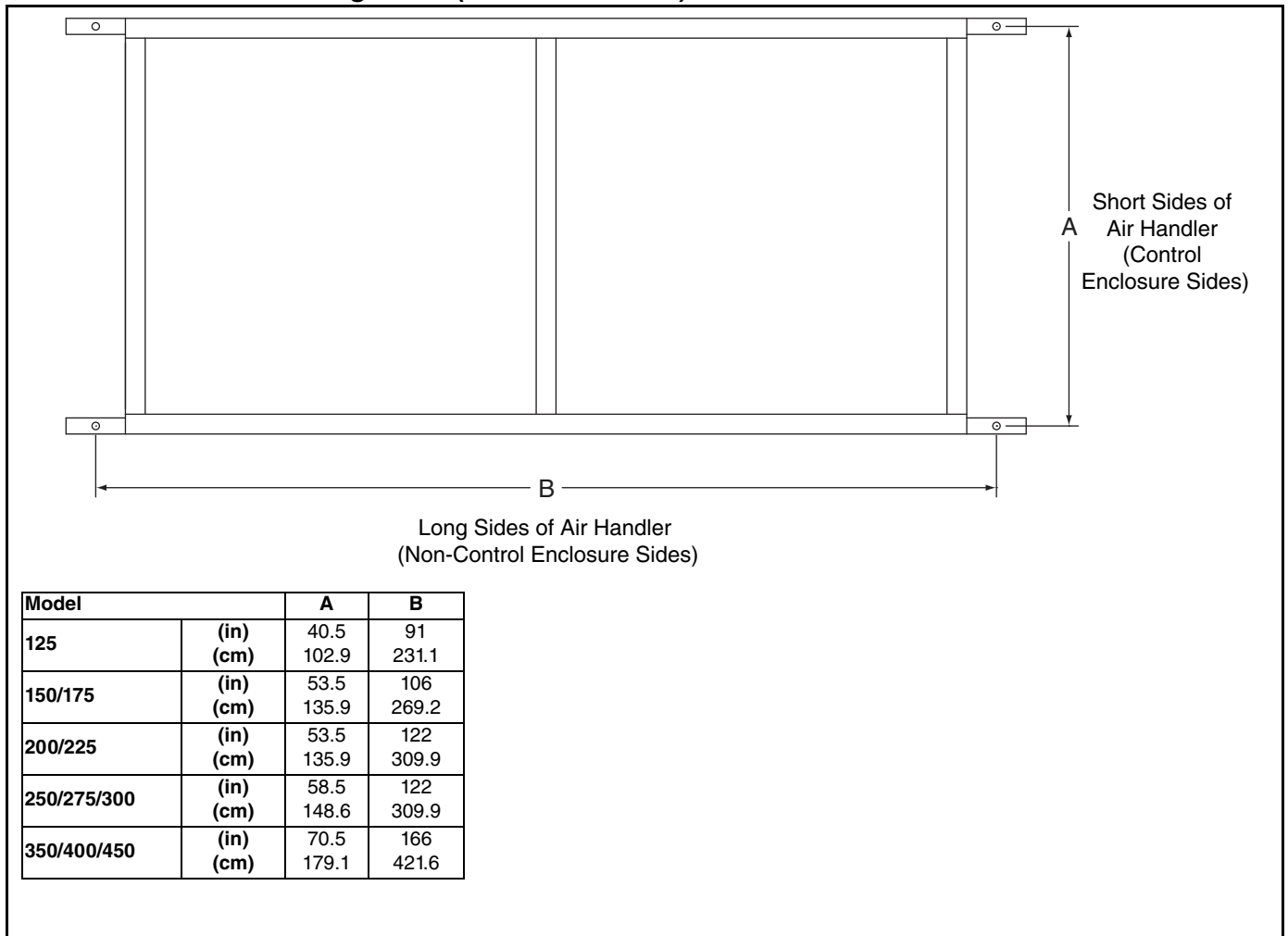

FIGURE 39: Stand Mounting Detail (Models 125 - 450)

SECTION 11: FILTER SECTION

⚠ WARNING			
			
<p>Crush Hazard Use proper lifting equipment and practices.</p>	<p>Falling Hazard Use proper safety equipment and practices to avoid falling.</p>	<p>Severe Injury Hazard Use proper lifting practices and equipment. Equipment and accessories are heavy.</p>	<p>Cut/Pinch Hazard Wear protective gear during installation, operation and service. Edges are sharp.</p>
<p>Failure to follow these instructions can result in death, injury or property damage.</p>			

All filter sections are shipped assembled.

NOTE: Check to be sure that all required components are present. If any are missing, contact your ROBERTS GORDON® independent distributor.

11.1 Filter Section Installation - Horizontal Air Handlers (Models 35 - 450)

For installation directly onto the inlet of the air handler, use the supplied hardware and bolt the filter section to the air handler through the pre-drilled holes. Supplied hardware must be torqued to recommended specifications on Page 13, Table 1. Caulk (provided by others) the sides, roof and bottom seams between the filter section and air handler.

Once caulk has been applied, the provided roof seam cover should be drill screwed over the caulked seam every 12" (30.5 cm) with the provided drill screws. See Page 27, Table 14 for quantity of screws required. Verify that the factory installed filters are properly placed and filter access door is secured in the closed position. For details See Page 49, Figure 40.

FIGURE 40: Filter Section Installation on Horizontal Air Handler

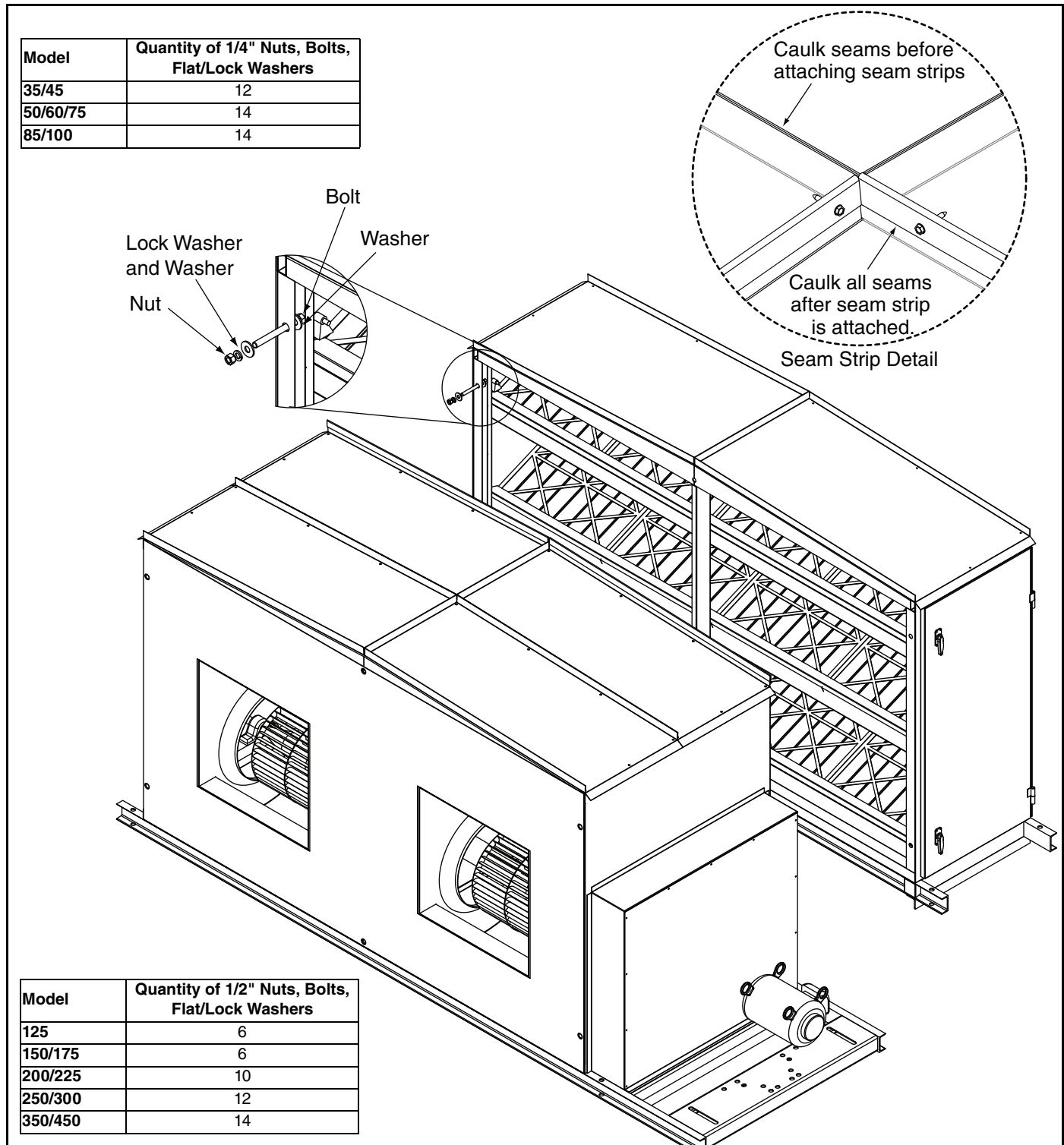

11.2 Filter Section Installation - Upright Air Handlers (Models 35 - 450)

For installation directly onto the inlet of the air handler, use the supplied hardware and bolt the filter section to the air handler through pre-drilled holes. If the air handler and filter section are to be set on a stand, mount the filter section on the stand first and then install the air handler. See Page 45, Section 10.2. Supplied hardware must be torqued to recommended specifications on Page 13, Table 1. Caulk (provided by others) the seams between the filter section and air handler. Verify that the factory installed filters are properly placed and filter access door is secured in the closed position. For details See Page 50, Figure 41.

FIGURE 41: Filter Section Installation on Upright Air Handler

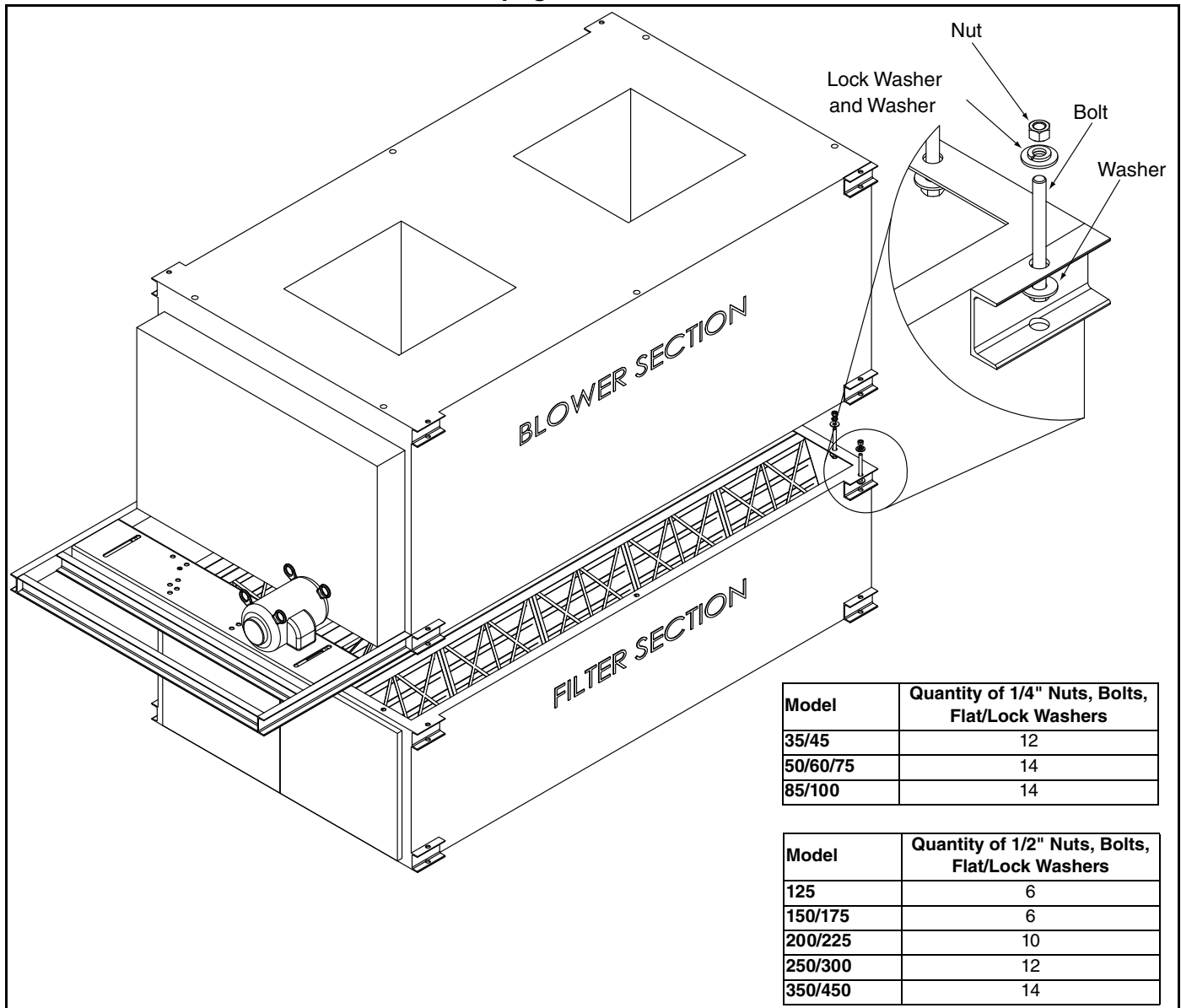

SECTION 12: MIXING BOX

⚠ WARNING			
			
Crush Hazard Use proper lifting equipment and practices.	Falling Hazard Use proper safety equipment and practices to avoid falling.	Severe Injury Hazard Use proper lifting practices and equipment. Equipment and accessories are heavy.	Cut/Pinch Hazard Wear protective gear during installation, operation and service. Edges are sharp.
Failure to follow these instructions can result in death, injury or property damage.			

All mixing box sections are shipped assembled with dampers installed.

14 for quantity of screws required. See Page 52, Figure 42.

NOTE: Check to be sure that all required components are present. If any are missing, contact your ROBERTS GORDON® independent distributor.

12.1 Mixing Box Section Installation - Horizontal Air Handlers (Models 35 - 450)

For installation directly onto the inlet of the air handler, use the supplied hardware and bolt the mixing box section with the air handler through pre-drilled holes. Supplied hardware must be torqued to recommended specifications on Page 13, Table 1. Caulk (provided by others) the sides, roof and bottom seams between the mixing box section and air handler. Once caulk has been applied, the provided roof seam cover should be drill screwed over the caulked seam every 12" (30.5 cm) with the provided drill screws. See Page 27, Table 14 for quantity of screws required.

For installation onto the filter section, first install filter section onto the inlet of the air handler through pre-drilled holes. See Page 49, Section 11.1. Use the supplied hardware and bolt the mixing box section to the filter section. Supplied hardware must be torqued to recommended specifications on Page 13, Table 1. Caulk (provided by others) the sides, roof and bottom seams between the mixing box section and filter section. Once caulk has been applied (see Page 28, Figure 20), the provided roof seam cover should be drill screwed over the caulked seam every 12" (30.5 cm) with the provided drill screws. See Page 27, Table

FIGURE 42: Mixing Box Section Installation on Horizontal Air Handler

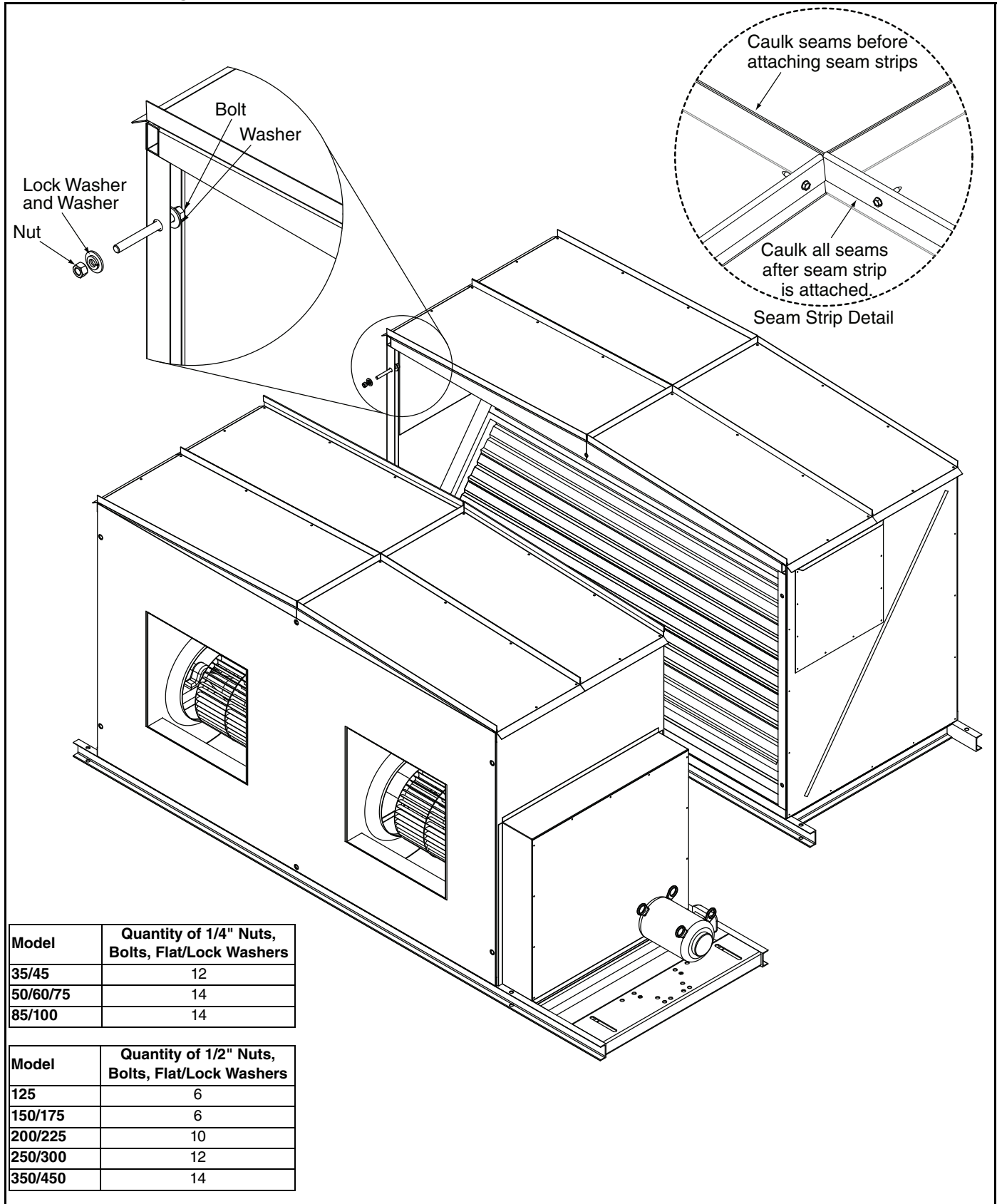

Model	Quantity of 1/4" Nuts, Bolts, Flat/Lock Washers
35/45	12
50/60/75	14
85/100	14

Model	Quantity of 1/2" Nuts, Bolts, Flat/Lock Washers
125	6
150/175	6
200/225	10
250/300	12
350/450	14

12.2 Mixing Box Section Installation - Upright Air Handlers (Models 35 - 450)

For installation directly onto the inlet of the air handler, use the supplied hardware and bolt the mixing box section to the air handler through pre-drilled holes. If the air handler and mixing box section are to be set on a stand, mount the mixing box section on the stand first and then install the air handler. See Page 45, Section 10.2. Supplied hardware must be torqued to recommended specifications on Page 13, Table 1. Caulk (provided by others) the seams between the mixing box section and air handler.

For installation onto the filter section, first install filter section onto the inlet of the air handler as per Page 50, Section 11.2 and then use the supplied hardware and bolt the mixing box section to the filter section through pre-drilled holes. If the air handler, filter section and mixing box section are to be set on a stand, mount the mixing box section on the stand first. Then install the filter section and air handler. See Page 45, Section 10.2. Supplied hardware must be torqued to recommended specifications on Page 13, Table 1. Caulk (provided by others) the sides, roof and bottom seams between the mixing box section and filter section. See Page 53, Figure 43.

FIGURE 43: Mixing Box Section Installation on Upright Air Handler

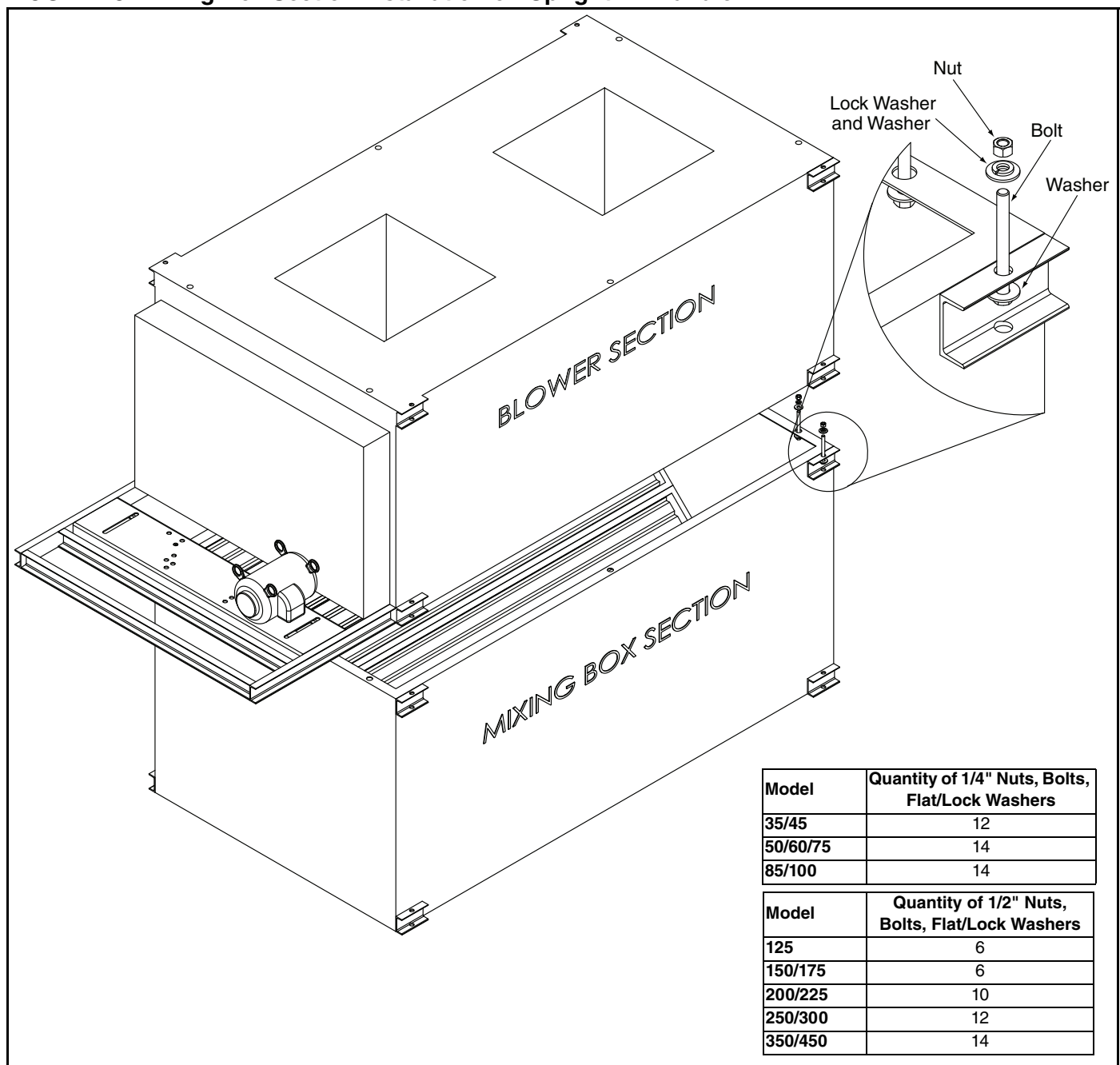

SECTION 13: INLET HOODS

⚠ WARNING			
			
<p>Crush Hazard Use proper lifting equipment and practices.</p>	<p>Falling Hazard Use proper safety equipment and practices to avoid falling.</p>	<p>Severe Injury Hazard Use proper lifting practices and equipment. Equipment and accessories are heavy.</p>	<p>Cut/Pinch Hazard Wear protective gear during installation, operation and service. Edges are sharp.</p>
<p>Failure to follow these instructions can result in death, injury or property damage.</p>			

For models 35 - 125, inlet hoods are shipped as one piece. For models 150 - 450, inlet hoods are shipped as five pieces (four hood sections and one brace). Assembly and installation take place simultaneously.

The inlet hood may be installed either onto the inlet of the air handler or to an outside wall.

After installing an inlet hood, all hardware must be tightened with a torque wrench to recommended specifications *on Page 13, Table 1*. In addition, all seams must be caulked (supplied by others).

13.1 Inlet Hood Installation (Models 35 - 125)

Inlet hoods for models 35 - 125 are shipped in one piece.

To install the inlet hood on the cabinet of the air handler, use the supplied hardware. Before mounting to air handler, install bird screens to inlet of air handler with zip ties (supplied by others) and sandwich between the air handler and the inlet hood. See Page 64, Section 15.2.

To install the inlet hood on an exterior wall, drill holes every 8" (20.3 cm) in the flanges of the inlet hood and mount with lag bolts (supplied by others).

FIGURE 44: Inlet Hood Installation to Air Handler (Models 35 - 125)

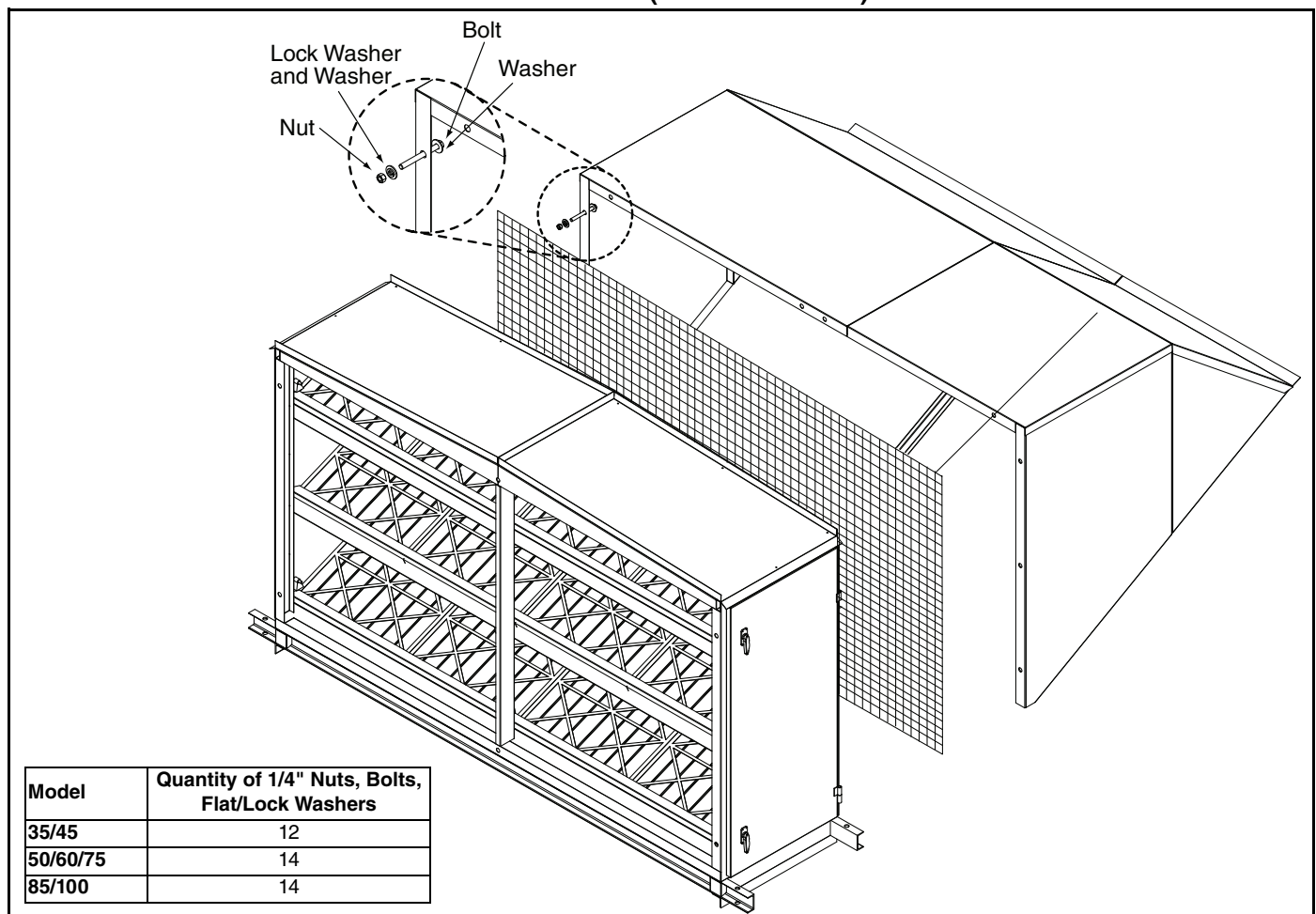

13.2 Inlet Hood Installation (Models 150 - 450)

Inlet hoods for models 150 - 450 are shipped in five pieces (four hood sections and one brace).

Before mounting inlet hood to air handler, install bird screens to inlet of air handler with zip ties (supplied by others) and sandwich between the air handler and the inlet hood. See *Page 57, Step 13.2.2*.

Step 13.2.1

Use supplied drill screws to fasten two large pieces together.

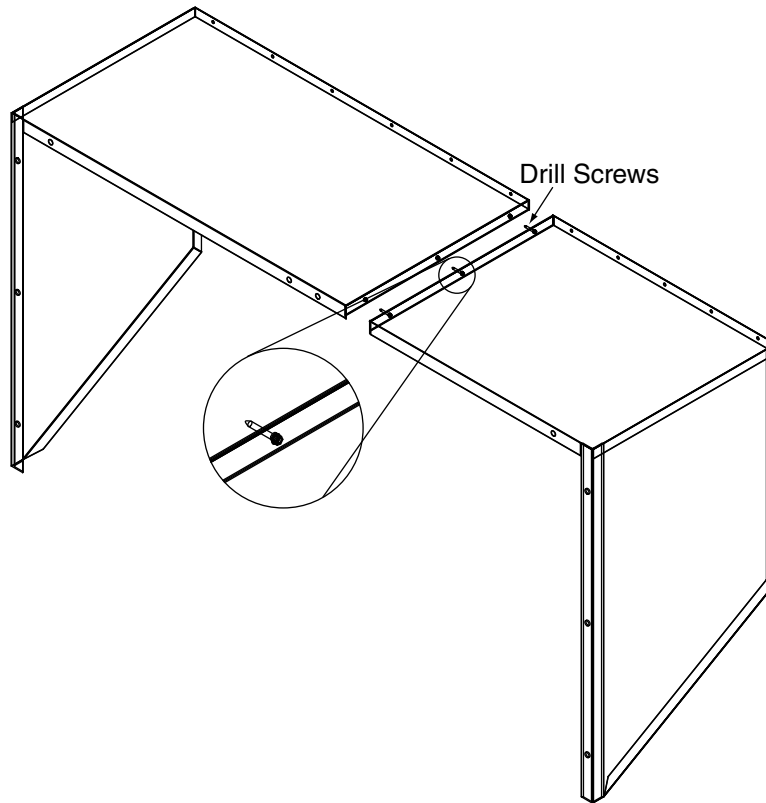

Step 13.2.2

Attach assembly to inlet section of air handler using supplied hardware.

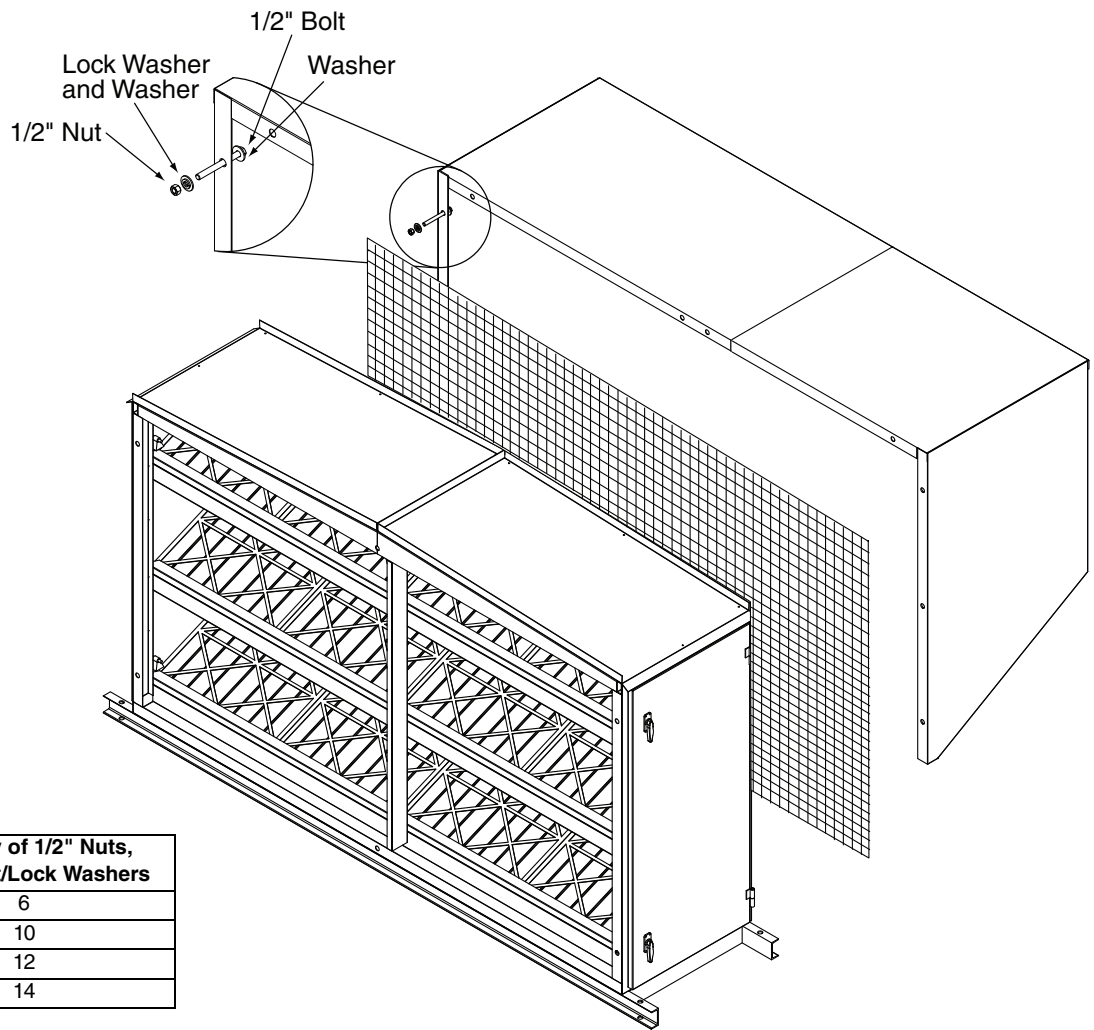
**Step 13.2.3**

Use supplied drill screws to fasten the smaller two pieces together.

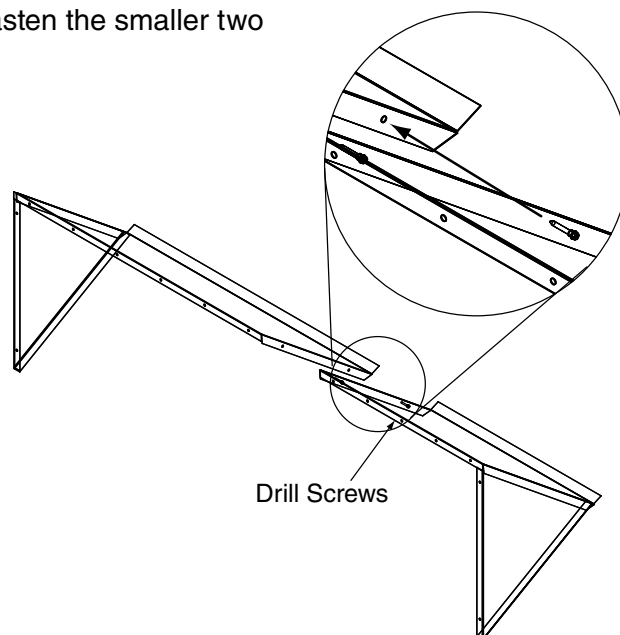

Step 13.2.4

Use supplied drill screws to attach assembly made in *Step 13.2.3* to the larger section of the inlet hood that was attached to the air handler in *Step 13.2.2*.

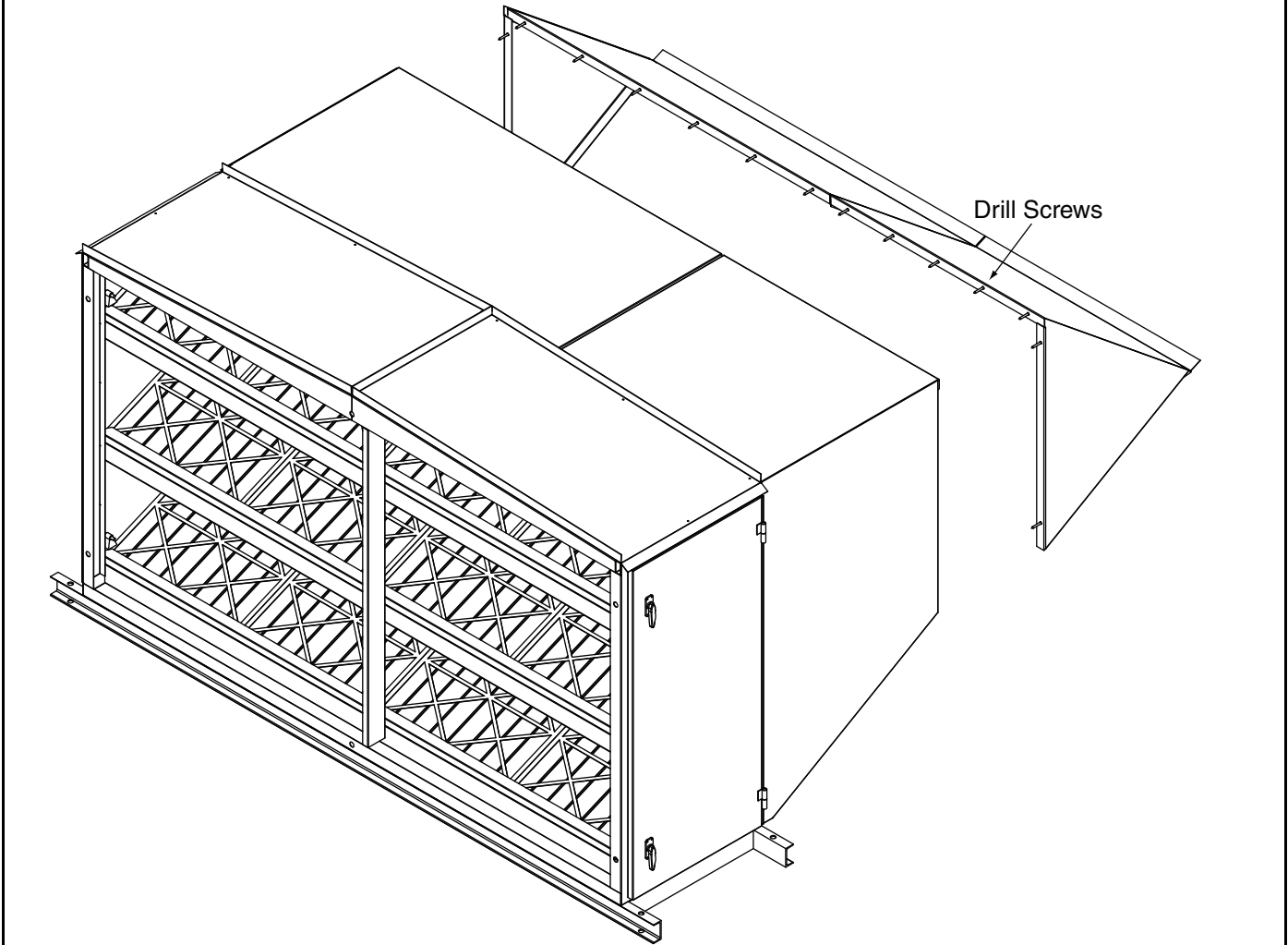

Step 13.2.5

Drill screw factory supplied hood support channel through side of support and side flanges of inlet hood.

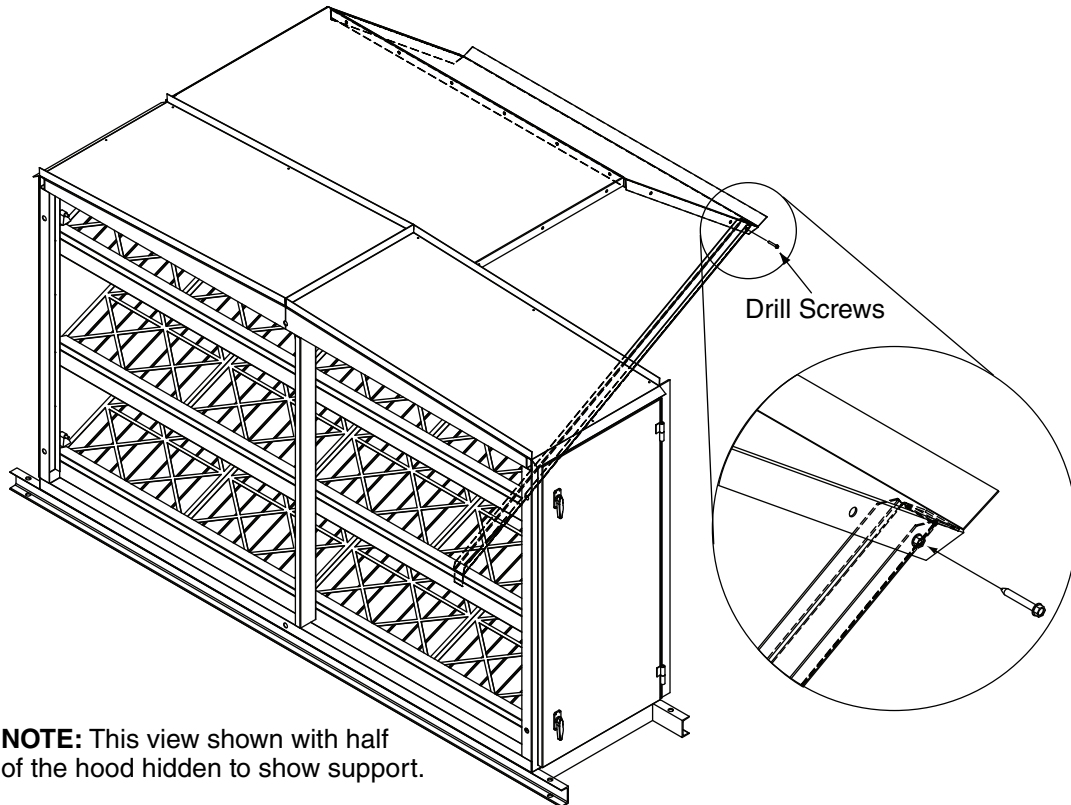
**Step 13.2.6**

Drill screw factory supplied hood support to bottom flange at base of air handler.

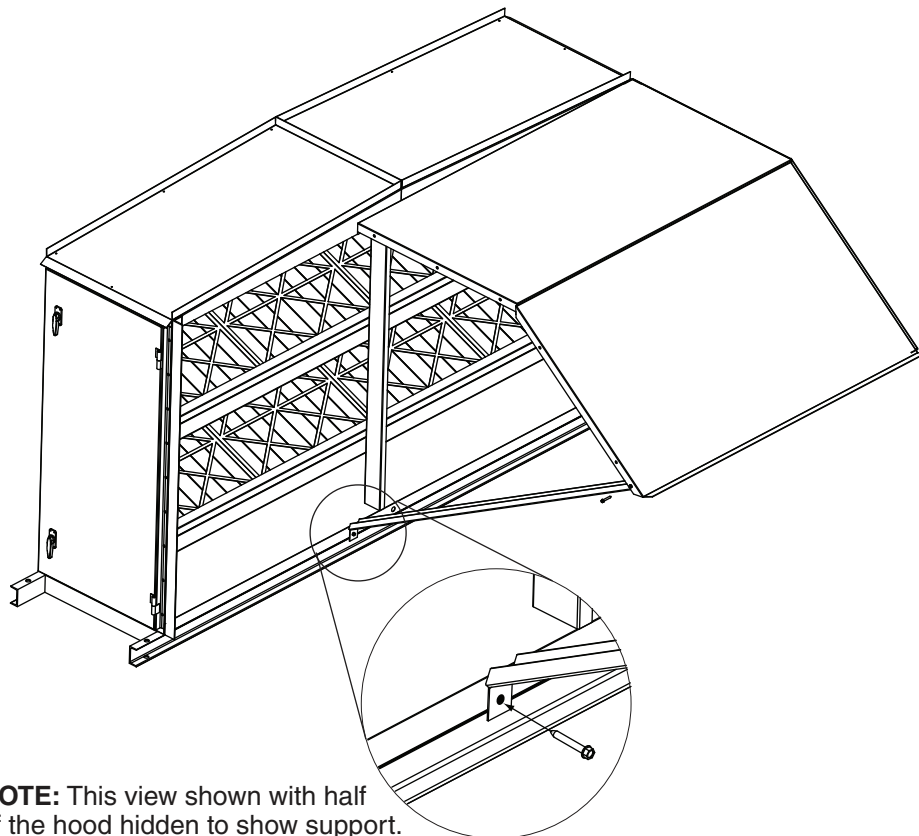

SECTION 14: SERVICE PLATFORM

⚠ WARNING			
			
<p>Crush Hazard Use proper lifting equipment and practices.</p>	<p>Falling Hazard Use proper safety equipment and practices to avoid falling.</p>	<p>Severe Injury Hazard Use proper lifting practices and equipment. Equipment and accessories are heavy.</p>	<p>Cut/Pinch Hazard Wear protective gear during installation, operation and service. Edges are sharp.</p>
<p>Failure to follow these instructions can result in death, injury or property damage.</p>			

All service platforms are shipped assembled and attached to the air handler on the control enclosure side. Upright air handlers supplied with both a stand and a service platform will have the service platform factory-mounted as an integral part of the stand. For custom upright units with different mounting locations, please refer to submittal drawings for specific details.

Service platform for all standard horizontal units (models 35 - 125) are welded to the burner/blower section. For custom horizontal units and for models 150 - 450, please refer to submittal drawings for specific details.

See Page 61, Figure 45 for layout and dimensions.

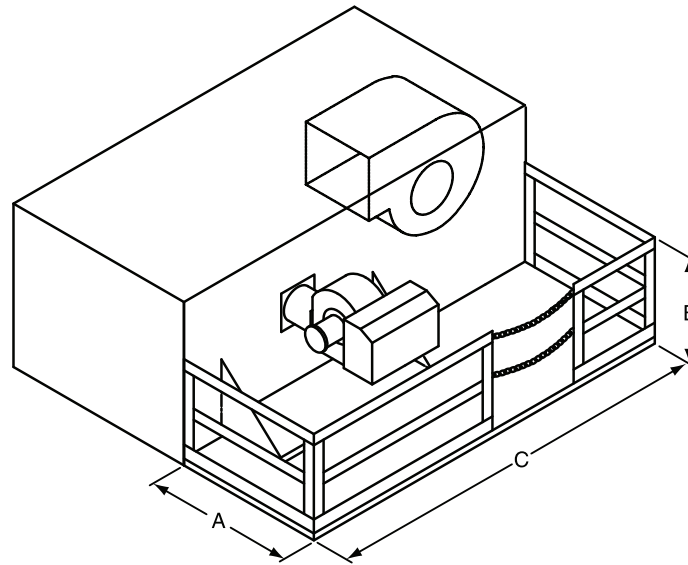
FIGURE 45: Horizontal Service Platform (Models 35 - 450)

Model		A	B	C			Weight			
				Burner and Blower Sections	Filter Section	Mixing Box Section		Burner and Blower Sections	Filter Section	Mixing Box Section
35/45	(in)	72.0	42.0	90.0	26.0	45.0	(lb)	480.0	240.0	240.0
	(cm)	182.9	106.7	228.6	66.0	114.3	(kg)	217.7	108.9	108.9
50/60/75	(in)	72.0	42.0	80.0	26.0	45.0	(lb)	480.0	240.0	240.0
	(cm)	182.9	106.7	203.2	66.0	114.3	(kg)	217.7	108.9	108.9
85/100	(in)	72.0	42.0	90.0	26.0	45.0	(lb)	660.0	470.0	470.0
	(cm)	182.9	106.7	228.6	66.0	114.3	(kg)	299.4	213.2	213.2
125	(in)	72.0	42.0	102.0	26.0	45.0	(lb)	800.0	470.0	470.0
	(cm)	182.9	106.7	259.1	66.0	114.3	(kg)	362.9	213.2	213.2
150/175	(in)	72.0	42.0	114.0	26.0	43.0	(lb)	940.0	550.0	550.0
	(cm)	182.9	106.7	289.6	66.0	109.2	(kg)	426.4	249.5	249.5
200/225	(in)	72.0	42.0	127.0	26.0	43.0	(lb)	1,100.0	550.0	550.0
	(cm)	182.9	106.7	322.6	66.0	109.2	(kg)	499.0	249.5	249.5
250/275/300	(in)	72.0	42.0	145.0	26.0	43.0	(lb)	1,100.0	630.0	630.0
	(cm)	182.9	106.7	368.3	66.0	109.2	(kg)	499.0	285.8	285.8
350/400/450	(in)	72.0	42.0	162.0	26.0	43.0	(lb)	1,260.0	630.0	630.0
	(cm)	182.9	106.7	411.5	66.0	109.2	(kg)	571.5	285.8	285.8

NOTE: To calculate the total length of the service platform, add together lengths of the applicable sections.
To calculate the total weight of the service platform, add together weights of the applicable sections.

FIGURE 46: Upright Service Platform (Models 35 - 450)

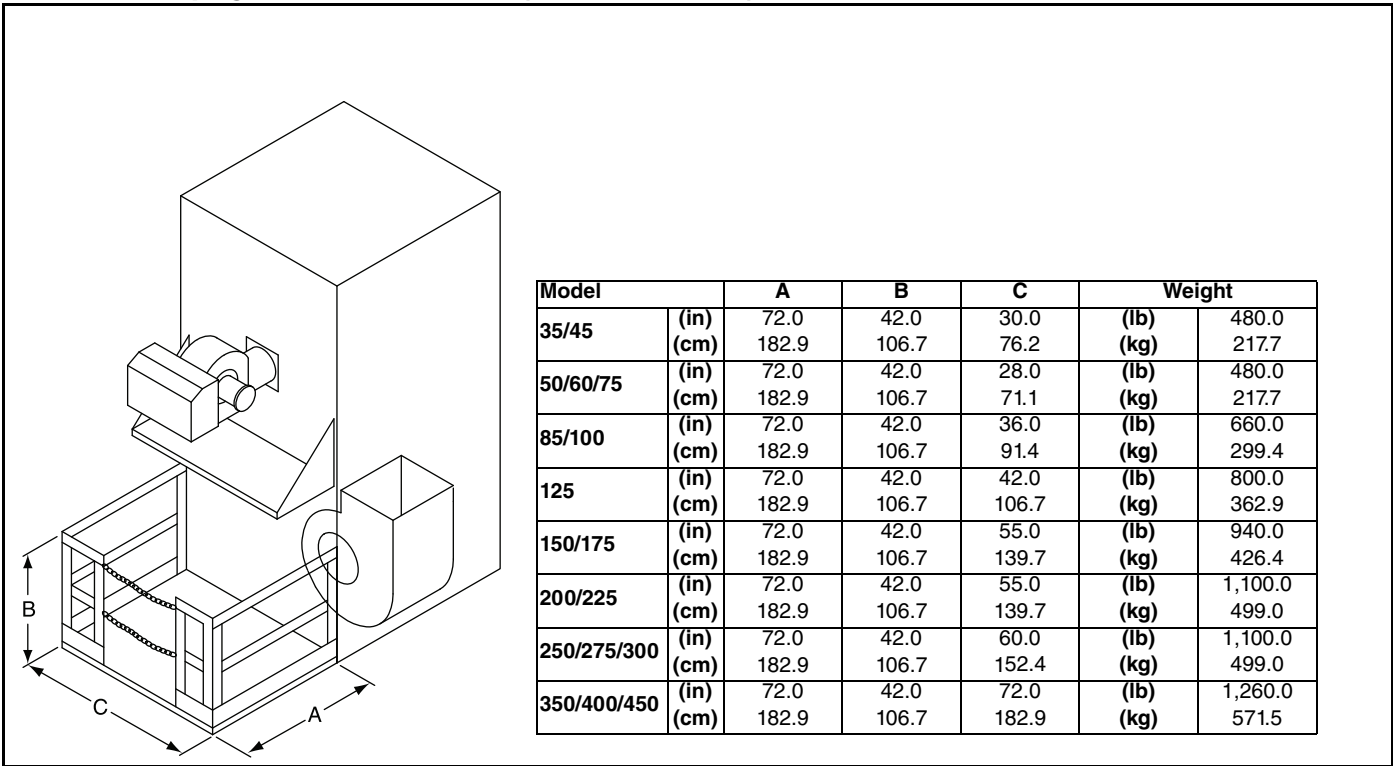

SECTION 15: DAMPERS

⚠ WARNING			
			
Crush Hazard Use proper lifting equipment and practices.	Falling Hazard Use proper safety equipment and practices to avoid falling.	Severe Injury Hazard Use proper lifting practices and equipment. Equipment and accessories are heavy.	Cut/Pinch Hazard Wear protective gear during installation, operation and service. Edges are sharp.
Failure to follow these instructions can result in death, injury or property damage.			

15.1 Discharge Damper Installation

As standard, discharge dampers ship mounted to the air handler except if the air handler is:

- In a horizontal orientation with a down discharge (all models).
- In a vertical orientation with a top discharge (Models 125, 350, 400 and 450).
- In a horizontal orientation with an end discharge (Models 350, 400 and 450).

If necessary, a customer may specify to ship loose an discharge damper that is normally factory mounted. Shipped loose discharge dampers are designed for mounting to the cabinet of the air handler (covering the discharge opening) or to an interior wall. It is recommended that a discharge damper be installed below the roof line for optimal access to the discharge damper actuator(s).

The discharge damper has four outward-turned flanges.

To install the discharge damper to the cabinet of the air handler, drive sheet metal screws or pop rivets (supplied by others) through the flanges into the air handler cabinet every 8" (20.5 cm) on all four sides of the discharge damper. See Page 64, Figure 47 which shows discharge damper for horizontal bottom hand arrangement.

To install the discharge damper on an interior wall, drill holes every 8" (20.5 cm) in the flanges on all four sides of the discharge dampers to accommodate lag bolts (supplied by others). See Page 64, Table 17 for recommended quantity of lag bolts to be installed.

No assembly is required for factory mounted discharge dampers.

FIGURE 47: Discharge Damper Installation for Horizontal Air Handler with Bottom Discharge

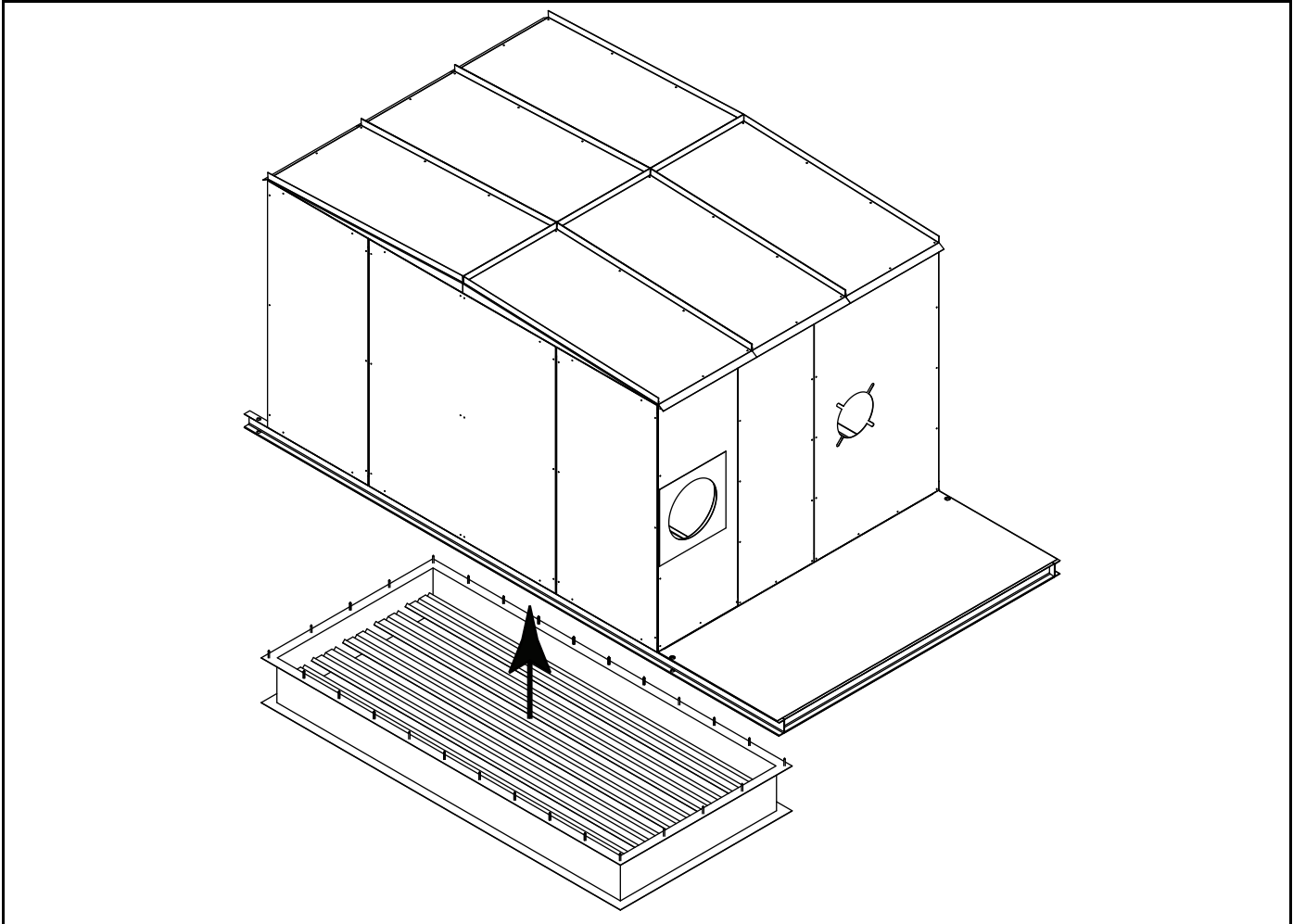

Table 17: Lag Bolts

Model	Quantity of Lag Bolts Recommended
35/45	18
50/65/75	20
85/100	20
125	28
150/175	32
200/225	34
250/300	36
350/450	52

To install the inlet damper to the face of the air handler, drive sheet metal screws or pop rivets (supplied by others) through the flanges into the air handler cabinet every 8" (20.5 cm) on all four sides of the inlet damper. See Page 65, Figure 48 for details.

To install the inlet damper on an exterior wall, drill holes every 8" (20.3 cm) in the flanges on all four sides of the inlet dampers to accommodate lag bolts (supplied by others). See Page 64, Table 17 for recommended quantity of lag bolts to be installed.

15.2 Inlet Damper Installation

As standard, inlet dampers ship mounted to the air handler except if the air handler does not have a filter section.

If necessary, a customer may specify to ship loose an inlet damper that is normally factory mounted. No assembly is required for factory mounted inlet dampers. Shipped loose inlet dampers are designed for mounting to the face of the air handler (covering the inlet opening) or to an exterior wall.

The inlet damper has four outward-turned flanges.

FIGURE 48: Inlet Damper

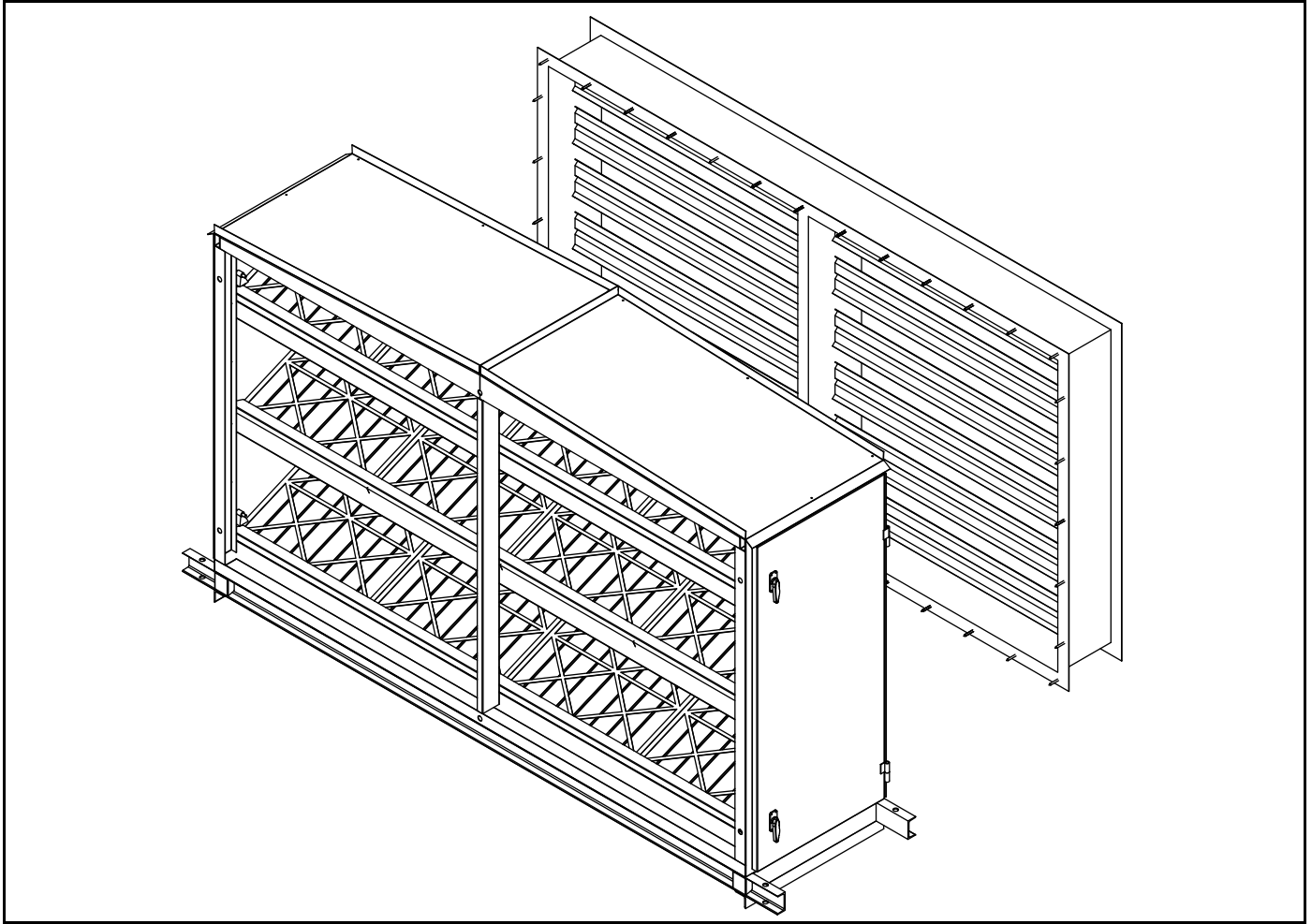

SECTION 16: DISCHARGE HEADS AND DISCHARGE LOUVERS

⚠ WARNING			
			
<p>Crush Hazard Use proper lifting equipment and practices.</p>	<p>Falling Hazard Use proper safety equipment and practices to avoid falling.</p>	<p>Severe Injury Hazard Use proper lifting practices and equipment. Equipment and accessories are heavy.</p>	<p>Cut/Pinch Hazard Wear protective gear during installation, operation and service. Edges are sharp.</p>
<p>Failure to follow these instructions can result in death, injury or property damage.</p>			

16.1 Discharge Heads' Installation

All discharge heads are shipped assembled. The discharge head is designed for mounting to the cabinet of the air handler (covering the discharge opening) or to an interior wall. The discharge head has four outward-turned flanges. To install discharge head to the cabinet of the air handler, drive sheet metal screws or pop rivets (supplied by others) through the flanges into the air handler cabinet every 8" (20.5 cm) on all four sides of the discharge head. In this type of installation, the discharge head must be field-supported.

To install the discharge head on an interior wall, drill holes every 8" (20.3 cm) in the flanges on all four sides of the discharge heads to accommodate lag bolts (supplied by others). See *Page 64, Table 17* for recommended quantity of lag bolts to be installed. In this type of installation, the discharge head is self-supporting; no other support is needed in a standard installation.

For four, three and one way discharge heads, see *Page 67, Figure 49* for layout and dimensions.

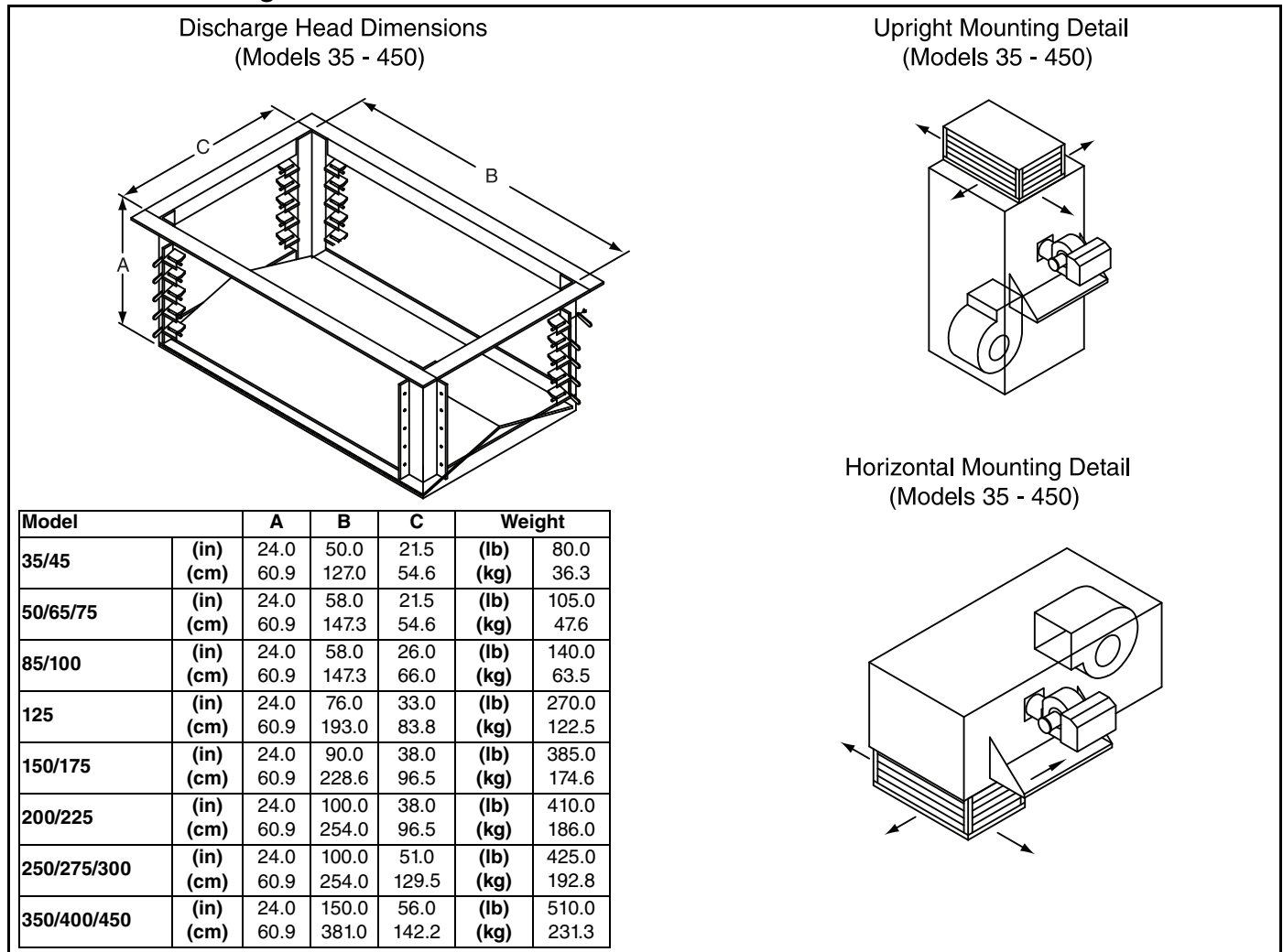
FIGURE 49: Discharge Heads

16.2 Discharge Louvers' Installation

All discharge louvers are shipped assembled. The discharge louvers are designed for mounting to the cabinet of the air handler (covering the discharge opening) or to an interior wall. To install the discharge louvers to the cabinet of the air handler, drive sheet metal screws or pop rivets (supplied by others) through the flanges into the air handler cabinet every 8" (20.3 cm) on all four sides of the discharge louvers. In this type of installation, the discharge louvers must be field-supported.

To install the discharge louvers on an interior wall, drill holes every 8" (20.3 cm) in the flanges on all four sides of the discharge louvers to accommodate lag bolts (supplied by others). See *Page 64, Table 17* for recommended quantity of lag bolts to be installed. In this type of installation, the discharge louvers are self-supporting; no other support is needed in a standard installation.

See *Page 68, Figure 50* for layout and dimensions.

FIGURE 50: Double Deflection Discharge Louvers

Discharge Louvers Dimensions
(Models 35 - 450)

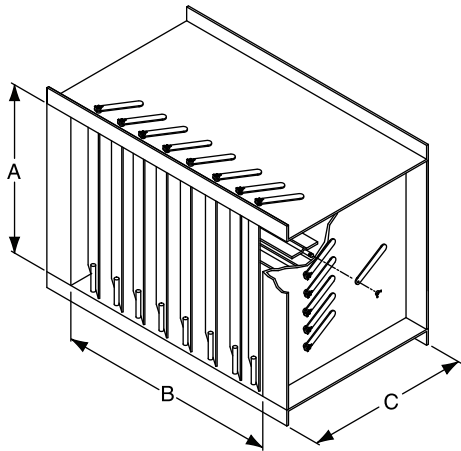

Upright Mounting Detail
(Models 35 - 450)

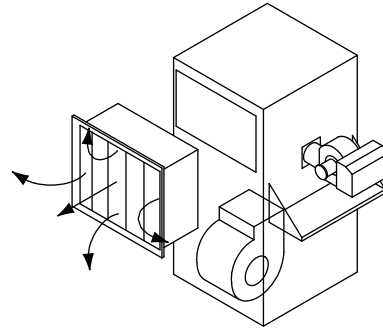

Horizontal Mounting Detail
(Models 35 - 450)

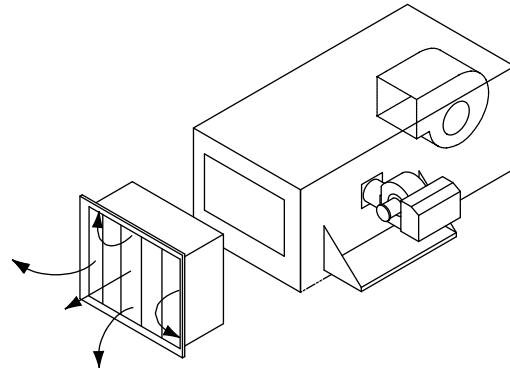

Model		A	B	C	Weight	
35/45	(in)	21.5	50	24.0	(lb)	70.0
	(cm)	54.6	127.0	60.9	(kg)	31.8
50/65/75	(in)	21.5	58	24.0	(lb)	95.0
	(cm)	54.6	147.3	60.9	(kg)	43.1
85/100	(in)	26	58	24.0	(lb)	130.0
	(cm)	66.0	147.3	60.9	(kg)	59.0
125	(in)	33	76	24.0	(lb)	260.0
	(cm)	83.8	193.0	60.9	(kg)	117.9
150/175	(in)	38	90	24.0	(lb)	375.0
	(cm)	96.5	228.6	60.9	(kg)	170.1
200/225	(in)	38	100	24.0	(lb)	395.0
	(cm)	96.5	254.0	60.9	(kg)	179.2
250/275/300	(in)	51	100	24.0	(lb)	415.0
	(cm)	129.5	254.0	60.9	(kg)	188.2
350/400/450	(in)	56	150	24.0	(lb)	500.0
	(cm)	142.2	381.0	60.9	(kg)	226.8

SECTION 17: DUCT CONSIDERATIONS

The air handler has been designed to operate at the specific air volume and external static pressure that was ordered. This static pressure is generated by any additional components that are added to the heater (i.e. inlet hood, filter section, mix box, dampers, ductwork, discharge heads, etc). Additional static pressure beyond that ordered will affect the performance of the air handler and lessen the air volume that can be delivered.

Proper engineering methods need to be employed when calculating duct and component static pressure (i.e. 2009 ASHRAE Handbook - Fundamentals, Chapter 21).

The system ductwork must comply with Sheet Metal and Air Conditioning Contractors Nationals Association (SMACNA) or any other recognized standards.

It is recommended that flexible duct connections (with proper operating temperature rating) be incorporated into the duct work design to prevent the transmission of any vibrations, either mechanical or harmonic.

As a general rule, all ducts should have a straight run of at least 3 hydraulic duct diameters immediately before and after the air handler before adding any fittings, elbows, restrictions, etc.

Hydraulic duct diameter for round ducts (in inches):

$$D_h = d$$

D_h: hydraulic diameter

d: round duct inside diameter

Hydraulic duct diameter for rectangular ducts (in inches):

$$D_h = (2 \cdot H \cdot W) / (H + W)$$

D_h: hydraulic diameter

H: rectangular duct inside height

W: rectangular duct inside width

The air handler is not designed to support the weight of ductwork. Ductwork must be constructed in a fashion that is self-supporting.

Depending on the options ordered with the air handler, flanges (either external or internal) may be provided to facilitate connection of ductwork. In cases where flanges are not provided, flat surfaces on the exterior skin of the air handler are provided to facilitate connection of ductwork.

Neither the flanges nor exterior skin of the air handler are capable of supporting the load of the ductwork. Ductwork support must come from the structure itself

that the air handler is servicing. On horizontal runs, it is recommended that ductwork be supported every 6' (1.8 m) for ductwork that has a cross section of 10 ft² (0.9 m²) or less and every 4' (1.2 m) for ductwork which has a cross section of greater than 10 ft² (0.9 m²). On vertical runs, it is recommended that ductwork be supported every 10' (3.0 m). On both cases, supporting members should be sized to carry the weight load.

17.1 Inlet Duct Work

Inlet duct work height and width must be no smaller than the air handler inlet height and width and supply only uncontaminated air to the air handler. (See Page 16, Figure 12 through Page 19, Figure 15 for inlet dimensions).

17.2 Return Air Duct

Return air duct work height and width must be no smaller than the air handler return air opening height and width. (See Page 16, Figure 12 through Page 19, Figure 15 for return air opening dimensions).

17.3 Discharge Duct Work

Flexible connections on discharge ductwork must have a minimum temperature rating of 500° F (260° C).

Air handlers with twin blowers should have a common discharge duct. (See Page 69, Table 18 for minimum discharge duct sizes by model).

Table 18: Minimum Discharge Duct Connection Size

Model		Height	Width
35/45	(in)	21.5	50
	(cm)	54.6	127
50/65/75	(in)	21.5	58
	(cm)	54.6	147.3
85/100	(in)	26	58
	(cm)	66.0	147.3
125	(in)	33	76
	(cm)	83.8	193.0
150/175	(in)	38	90
	(cm)	96.5	228.6
200/225	(in)	38	100
	(cm)	96.5	254.0
250/275/300	(in)	51	100
	(cm)	129.5	254.0
350/400/450	(in)	56	150
	(cm)	142.2	381.0

SECTION 18: VENTING**! WARNING****Carbon Monoxide Hazard**

Air handler must be vented.

Air handler must be installed according to the installation manual.

Failure to follow these instructions can result in death or injury.

18.1 General Venting Requirements

This air handler must be vented in accordance with the rules contained in this manual and with the following national codes and any state, provincial or local codes which may apply:

United States: Refer to NFPA 54/ANSI Z223.1-latest revision, National Fuel Gas Code for natural gas and LPG units. Refer to NFPA Article 31 - latest revision, Standard for the Installation of Oil-Burning Equipment for oil units.

Canada: Refer to CSA B149.1 - latest revision, Natural Gas and Propane Installation Code for natural gas and LPG units. Refer to CSA B139 - latest revision, Installation Code for Oil-Burning Equipment for oil units.

18.2 Recommended Flue Venting Practices

All indirect-fired air handlers are shipped without flue/vent pipe components. It is the responsibility of the installer to supply the venting components.

All indirect fired air handlers must be vented. Each air handler must have an individual vent pipe and vent terminal.

Termination of the vent pipe must be located so that the combustion fumes can not be drawn back into the air handler or into any other outside air intakes.

Vent pipe diameter must match the diameter of the air handler's flue pipe extension. Recommended vent pipe is a minimum 26 gauge galvanized steel or stainless steel for models 35-75; minimum 16 gauge galvanized steel or stainless steel for models 85-450. The installer must provide a rain cap or weather cap.

All joints must be sealed. Type "B" vents are not acceptable.

Do not support the weight of the vent pipe on the equipment's flue pipe extension. Vent pipe must be self supporting.

On equipment with a high turndown burner, it is recommended to insulate single wall vent pipes.

Insulation must have a minimum temperature rating of 1000° F (537.8° C).

Maximum vent pipe length (horizontal or vertical) is 40' (12.2 m). A total equivalent vent pipe length can be calculated using equivalent straight pipe lengths for tees and elbows reducing the maximum vent pipe length by 6' (1.8 m) for each sweep elbow, 2.5' (.7 m) for the termination tee, and 10' (3.0 m) for each short radius elbow.

The vent pipe should be fitted with a drip leg with a clean out and a drain plug in the bottom. The vent pipe shall be constructed so that any water or condensate that collects in the vent will remain in the drip leg and not drain back into the air handler. Be sure the drip leg is constructed in a way that water or condensate will not fall on air handler's controls when drain plug is removed on gas-fired air handlers only. Pitch horizontal vents downward 1/4" (.6 cm) per foot toward outlet for condensate drainage. On oil-fired and combination gas-fired/oil-fired air handlers, pitch horizontal vents downward 1/4" (.6 cm) per 1' (.3 m) towards the air handler for drainage. Support horizontal runs as required to prevent sagging.

Do not install dampers or other restrictive devices in the vent pipe.

On air handlers installed outdoors, vertical portions of vent pipe must be a minimum of 5' (1.5 m) above the roofline of the air handler. Guide wires may be required to brace the vent pipe.

The vent pipe should not be installed in such a manner that access to the components is obstructed.

Maximum clearances to combustibles around the vent pipe are significantly higher than for the air handler.

The vent pipe shall have a minimum of at least 36" (91.4 cm) clearance to combustibles, and be guarded to protect personnel from coming in contact.

Approved listed thimble is to be used wherever the vent pipe passes through a combustible wall or ceiling/roof.

18.3 Heat Exchanger Condensate Drain Connection

Indirect fired air handlers are provided with a male NPT condensate drain connection. Refer to the air handler drawings for the exact location. This connection must be extended away from the air handler for proper drainage. Use pipe, preferably stainless steel or similar material that will be non-corrosive and can handle the high heat.

On indoor air handlers, a P-Trap is preferred and should be constructed using *Page 71, Figure 51* as a guideline.

FIGURE 51: Condensate Drain

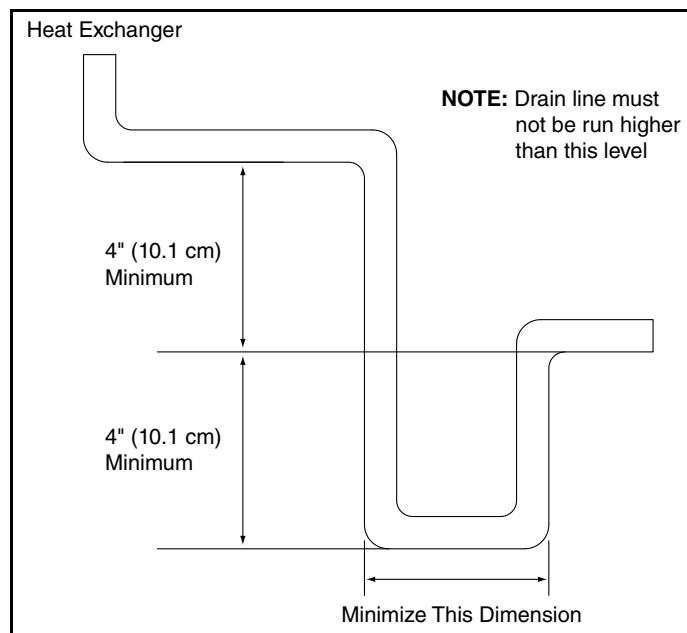

A P-Trap should not be installed on outdoor air handlers as the condensate could be exposed to freezing temperatures. Drainage of condensate directly onto the roof may be acceptable; refer to local codes. It is recommended that a small drip pad of either stone, mortar, wood or metal be provided to protect the roof against possible damage.

If condensate is to be piped into the building drainage system, the drain line should be pitched away from the unit at a minimum of 1/8" (.32 cm) per foot. The drain line must penetrate the roof external to the air handler. Refer to local codes for additional requirements. Sealed drain lines require venting to assure proper condensate flow.

SECTION 19: BURNERS**⚠ WARNING****Explosion Hazard**

Leak test all components of gas/oil piping before operation.

Gas/oil can leak if piping is not installed properly.

Do not high pressure test gas/oil piping with air handler connected.

Failure to follow these instructions can result in death, injury or property damage.

19.1 Principle of Operation

The burner is a self-contained unit comprised of a blower assembly, firing head, igniter and flame monitoring system. Gas burners use multiple orifices with venturi operation for proper combustion.

Oil burners use pressure atomization for proper combustion.

The "Type J" burner is used on gas-fired air handlers with an input of 300 - 2,200 MBH (87.9 - 644.8 kW). See Page 72, Figure 52. The "Type C" burner is used on all oil-fired air handlers and on gas-fired air handlers with an input of 2,201 - 5,625 MBH (644.9 - 1648.5 kW). See Page 73, Figure 53.

For more information on the burner provided in a specific air handler, refer to the burner manufacturer's documentation with the air handler.

Air for combustion is furnished by an integrally mounted, motor-driven combustion air fan and is controlled by a multi-louvered damper assembly. The combustion air then discharges into the burner blast tube assembly. High turbulence flow is controlled by means of an adjustable fan diffuser system.

The different modes of operation are achieved by using appropriate control valves and fuel/air actuators. Burners are available with on/off, high/low/off and full modulating modes. The air/fuel ratio is established at the time of start-up and proven with combustion test equipment to provide the lowest practical emissions with a clean flame. See Page 136, Section 25.9 through Page 137, Section 25.10 for proper procedures and emission levels.

FIGURE 52: Typical "Type J" Burner

FIGURE 53: Typical "Type C" Burner**19.2 Burner Pilot Assemblies**

"Type J" burners on the air handlers can utilize either a flame rod (natural gas only) or a ultraviolet scanner. On/Off, High/Low/Off and 3:1 modulating natural gas "J" burners use a flame rod as standard. 8:1 and 10:1 modulating natural gas "J" burners and all LPG "J" burners use a ultraviolet scanner as standard.

All "Type C" burners use an ultraviolet scanner. All burners are preset at the factory for proper operation and firing rate. If field re-adjustment of ignition electrodes or flame rod is required refer to *Page 73, Figure 54 through Page 76, Figure 57* for the proper pilot assembly set-up.

FIGURE 54: "Type J" Burner with Flame Rod - Natural Gas Only (Not for use with LPG)**19.3 Combustion Air Intake Collar**

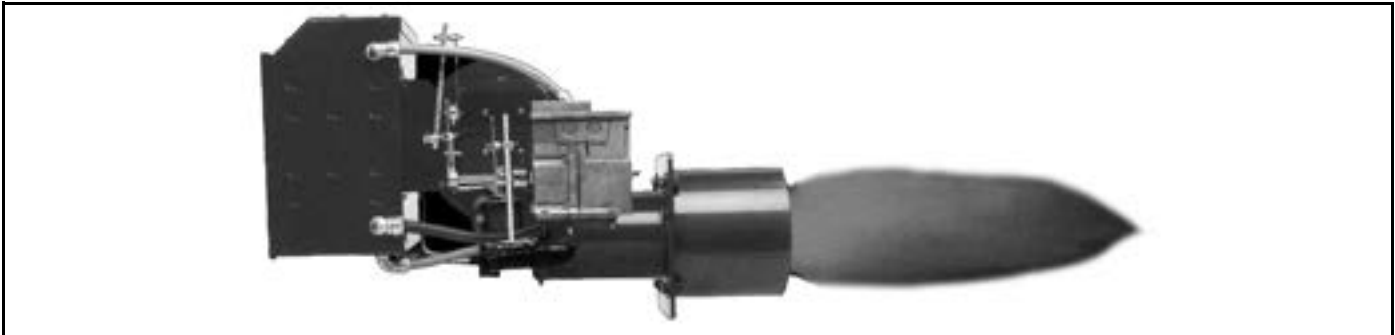
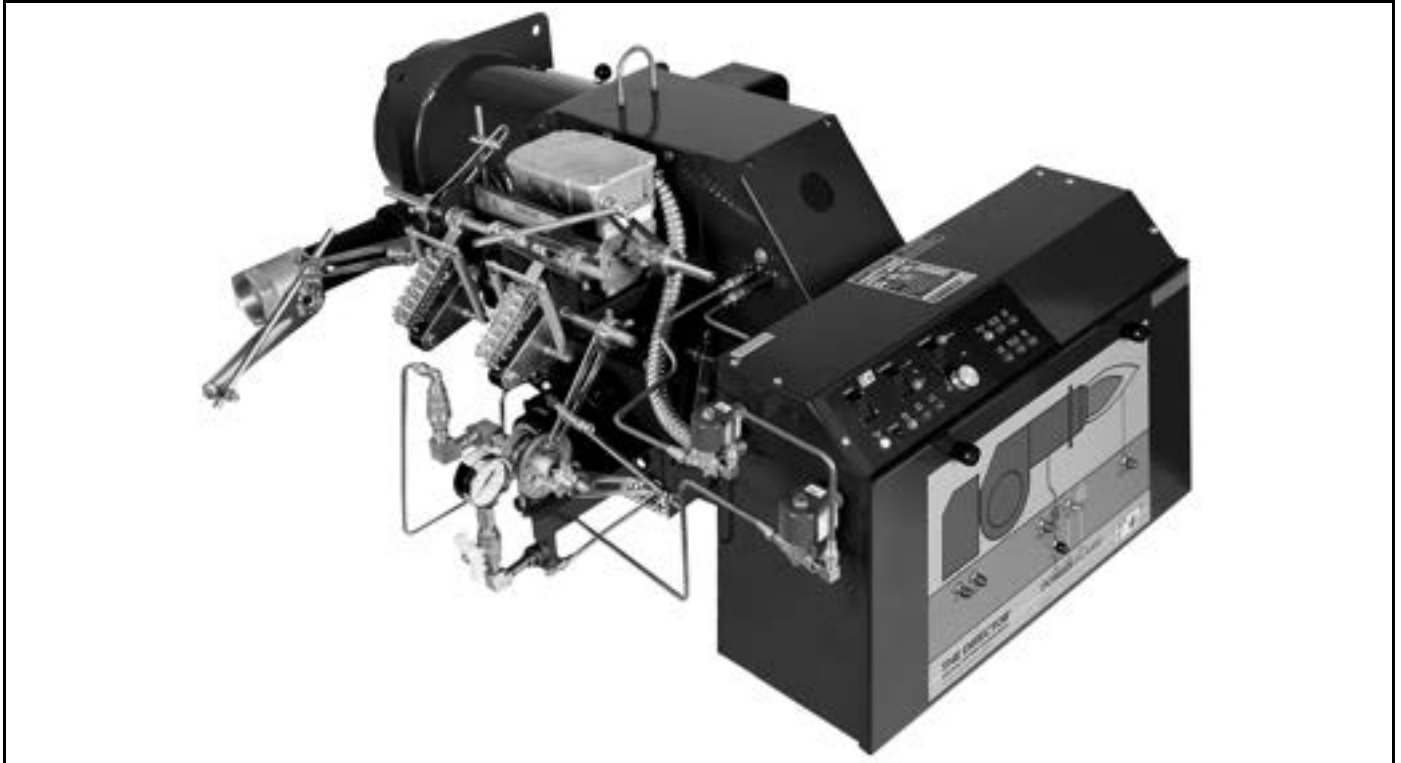
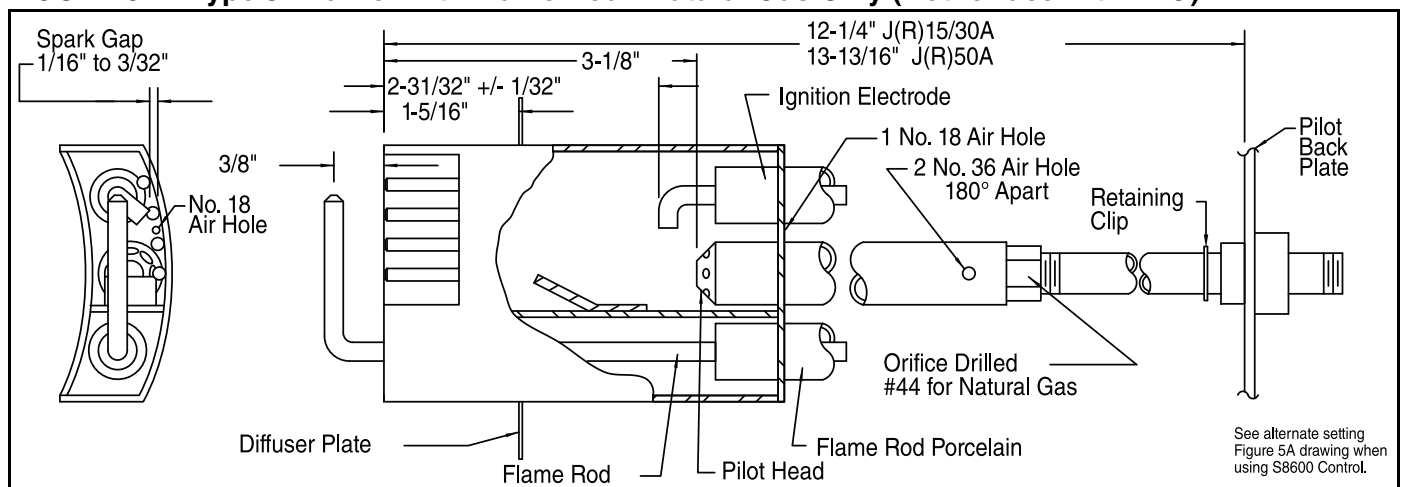
A burner can be factory-fitted with an optional combustion air intake collar, thereby allowing the

burner to pull its combustion air from outside of the unit's immediate vicinity. This collar adapts the square combustion air intake of the burner to a round duct connector or converts it to a square duct flange.

See Page 74, Table 19 for standard burner collar diameter / flange size. Consult factory for non-standard burners as collar diameters / flanges may vary.

Table 19: Combustion Air Duct Collar Sizing

Type	Size - Outer Dimensions		Burner Type			
			Gas		Oil and Gas/Oil	
			Max Input (MBH)	Max Input (kW)	Max Input (MBH)	Max Input (kW)
Round	6.0	15.2	1075	315	1360	398.6
Round	8.0	20.3	2200	644.8	2200	644.8
Square	8.0	20.3	5250	1538.6	5250	1538.6
Square	12.0	30.5	5600	1641.2	5600	1641.2

When ducting outside combustion air to the burner air inlet, several considerations must be taken in account:

- Temperature variations when using outside fresh air: Changes in air temperature affect density of the air and the volume of air delivered to the combustion process. This must be taken in

account when performing combustion performance. For example: For each 30° F (33.3° C) change in the air temperature, a 1% change in the oxygen reading will be experienced.

- Condensation in the fresh air duct: A drain connection is required in the lowest point of the duct or the duct must be pitched a minimum of a 0.25" (.6 cm) per foot (30.5 cm) away from the burner for condensate drainage.
- Duct Sizing: Size the fresh air duct to provide a minimum of 20 CFM (34 m³/h) per 10,000 Btu/hr (2,931 kW) of input firing rate. The velocity of the air must not exceed 1000 FPM (5.0 m/s) and cause less than 0.1" wc (<.25 mbar) pressure drop, including all screens, filters and fittings. The inlet to this duct must be protected from weather (rain, snow and/or ice) and must have an inlet screen to protect from pest and debris.

FIGURE 55: "Type J" Burner with Ultraviolet Scanner - Natural Gas or LPG

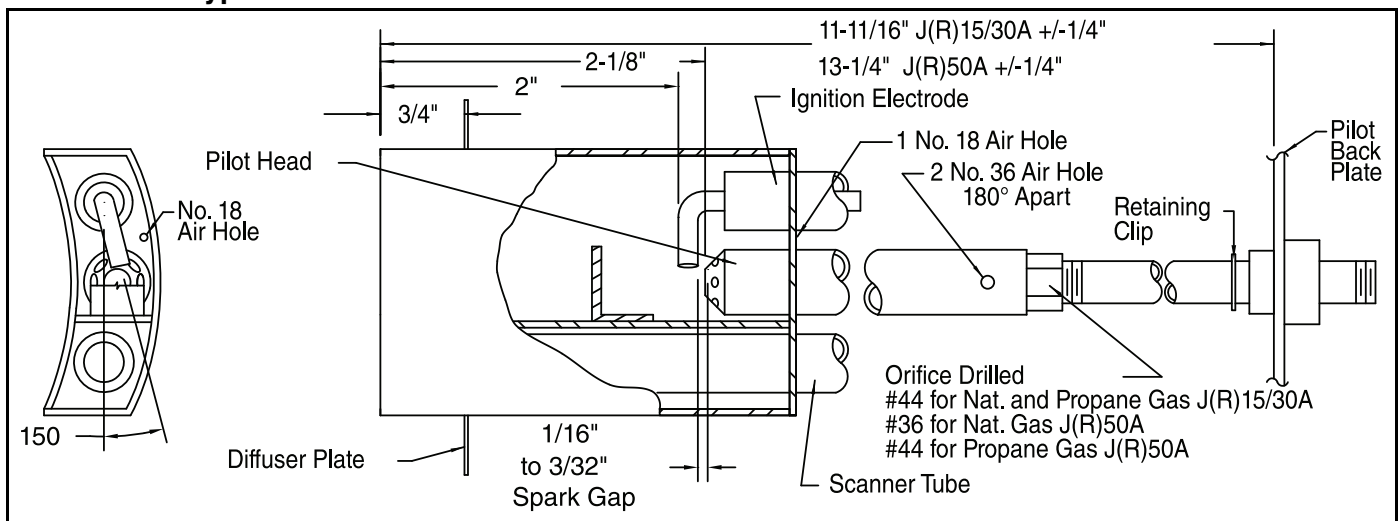
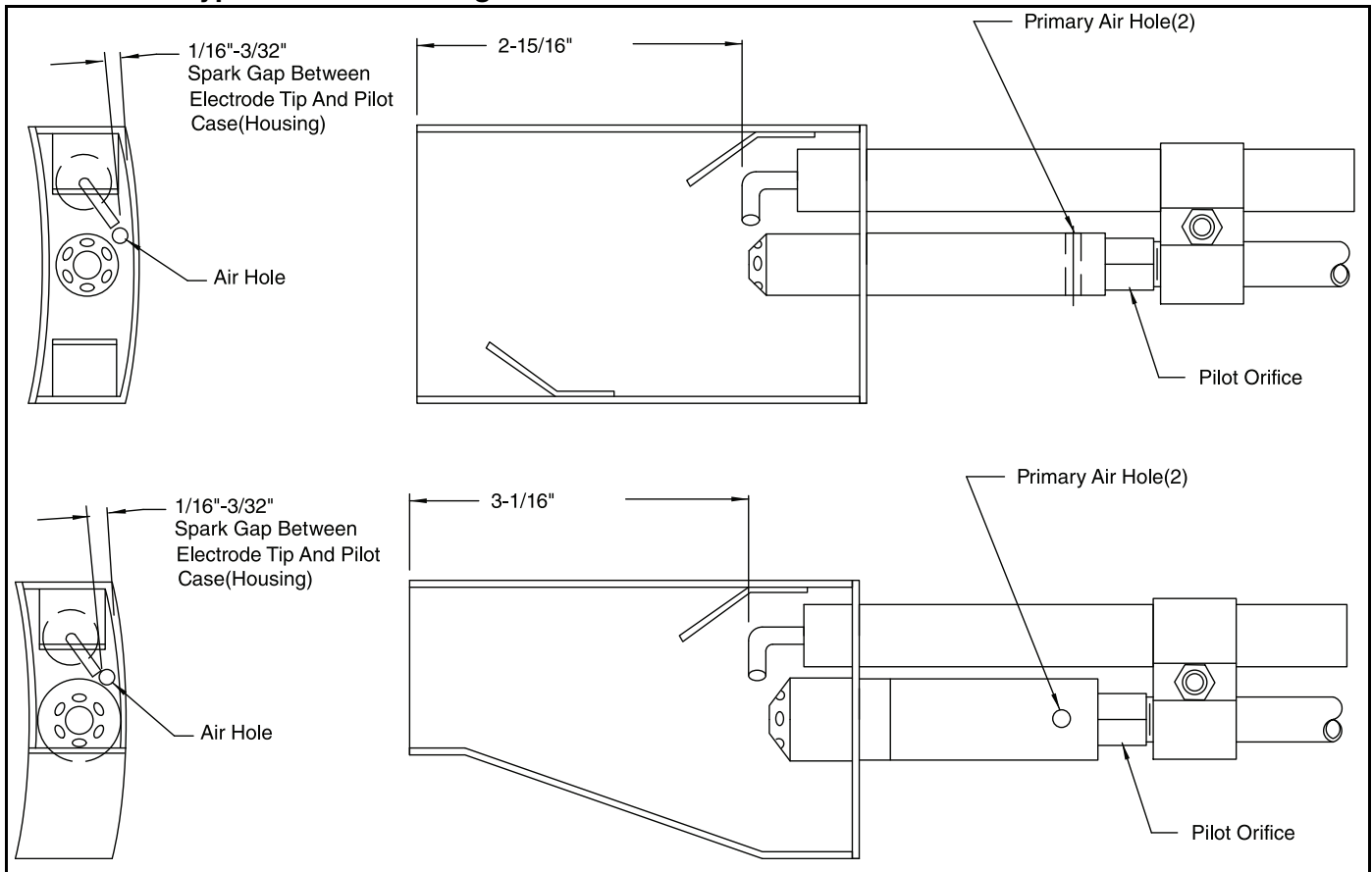
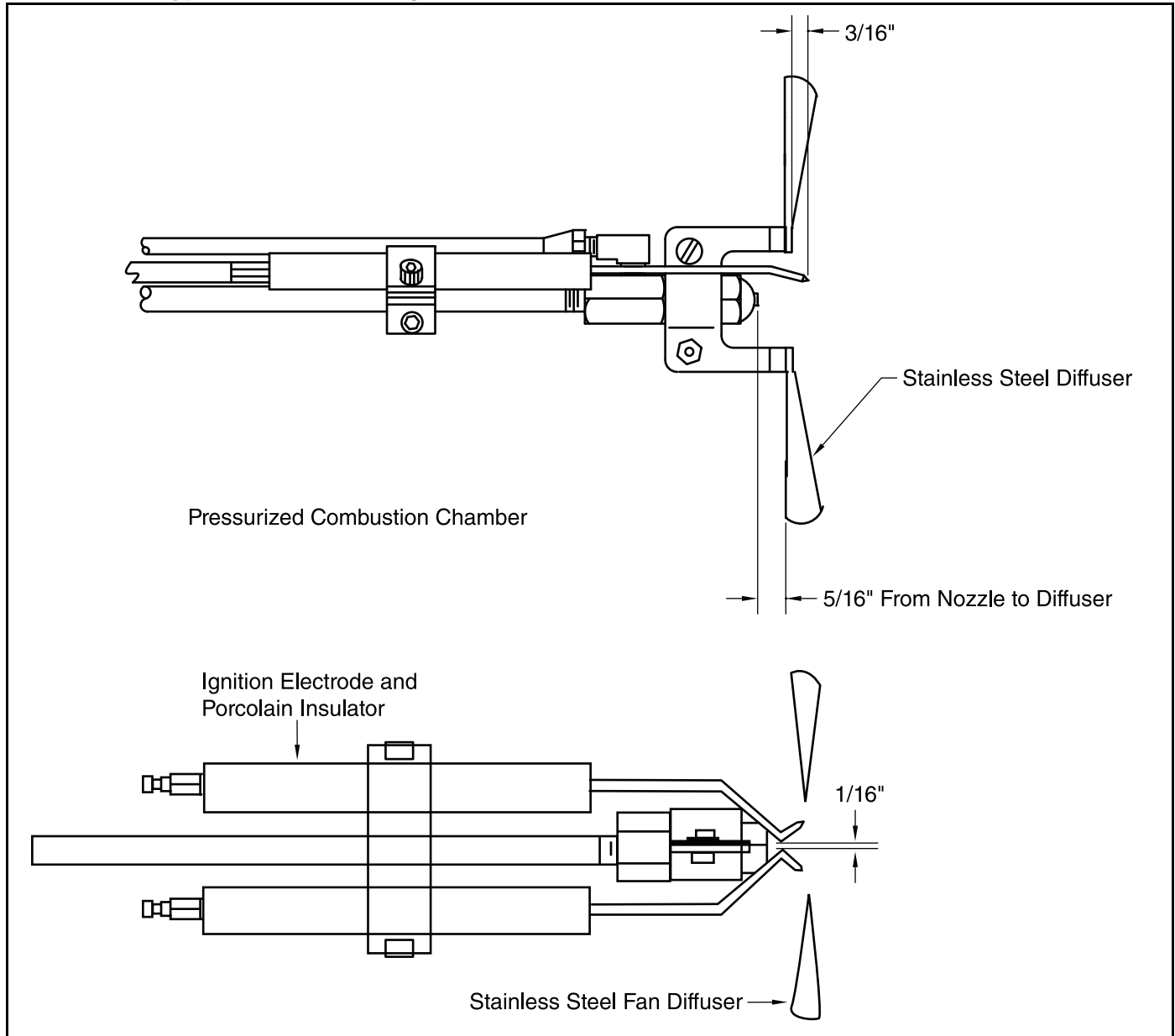



FIGURE 56: "Type C" Burner with Ignition Electrode - Natural Gas or LPG

NOTE: "Type C" Gas Burner - The arc from the electrode tip should jump from the tip to the body of pilot housing and should be lined up with the hole in the backside of pilot housing, so that the blower air passing through this hole will cause the arc to flag or move around. Normal spark gap should be 1/16" (1.6 mm) - 3/32" 2.4 mm). Electrode should not be moved so far forward that the pilot flame will impinge on the porcelain insulator. This condition will cause the porcelain to crack and break off at the point of flame impingement.

FIGURE 57: "Type C" Burner with Ignition Electrode - Oil



SECTION 20: GAS PIPING FOR GAS-FIRED AIR HANDLERS

⚠ WARNING

Explosion Hazard
<p>Leak test all components of gas/oil piping before operation.</p> <p>Gas/oil can leak if piping is not installed properly.</p> <p>Do not high pressure test gas/oil piping with air handler connected.</p> <p>Failure to follow these instructions can result in death, injury or property damage.</p>

pressure gas regulator and safety shut off valve.

For minimum inlet gas pressures refer to *Page 78, Table 20.*

20.1 Gas Manifolds

All gas piping to the air handler must comply with:

United States: Refer to NFPA 54/ANSI Z223.1-latest revision, National Fuel Gas Code for natural gas and LPG units. Refer to NFPA Article 31 - latest revision, Standard for the Installation of Oil-Burning Equipment for oil units.

Canada: Refer to CSA B149.1 - latest revision, Natural Gas and Propane Installation Code for natural gas and LPG units. Refer to CSA B139 - latest revision, Installation Code for Oil-Burning Equipment for oil units.

The air handlers are available with two different types of manifolds:

- Factory Mutual (FM)/Underwriters Laboratories (UL) Compliant
- XL Insurance (former Industrial Risk Insurers[IRI]) Compliant

20.2 Gas Piping and Pressures

The air handler is equipped with a gas manifold suitable for connection to supply pressure of up to 1 PSIG (68.9 mbar). When gas supply exceeds this maximum gas pressure, an additional high pressure gas regulator will be required to insure that the correct gas pressure is supplied to the regulator. Pressure should be measured between the high

Table 20: Gas Manifold Size

Model	Minimum Heat Output		Maximum Heat Input		Gas NPT Connection	Minimum Inlet Gas Pressure
	MBH	kW	MBH	kW	in	in wc
35	300	88	435	127	1.00	7.0
45	300	88	560	164	1.00	7.0
50	300	88	630	185	1.00	7.0
65	640	188	810	237	1.00	10.0
75	650	190	938	275	1.00	10.0
	939	275	940	275	1.25	7.0
85	650	190	938	275	1.00	10.0
	939	275	1,060	311	1.25	7.0
100	650	190	938	275	1.00	10.0
	939	275	1,250	366	1.25	8.0
125	700	205	938	275	1.00	10.0
	939	275	1,250	366	1.25	8.0
	1,251	367	1,565	459	1.50	10.0
150	700	205	938	275	1.00	10.0
	939	275	1,250	366	1.25	8.0
	1,251	367	1,875	550	1.50	10.0
	1,876	550	1,880	551	2.00	7.0
175	750	220	938	275	1.00	10.0
	939	275	1,250	366	1.25	8.0
	1,251	367	1,875	550	1.50	10.0
	1,876	550	2,190	642	2.00	7.0
200	750	220	938	275	1.00	10.0
	939	275	1,250	366	1.25	8.0
	1,251	367	1,875	550	1.50	10.0
	1,876	550	2,500	733	2.00	10.0
225	750	220	938	275	1.00	10.0
	939	275	1,250	366	1.25	8.0
	1,251	367	1,875	550	1.50	10.0
	1,876	550	2,800	821	2.00	10.0
250	750	220	938	275	1.00	10.0
	939	275	1,250	366	1.25	8.0
	1,251	367	1,875	550	1.50	10.0
	1,876	550	3,125	916	2.00	10.0
	3,126	916	3,130	917	2.50	8.0
275	900	264	938	275	1.00	10.0
	939	275	1,250	366	1.25	8.0
	1,251	367	1,875	550	1.50	10.0
	1,876	550	3,125	916	2.00	10.0
	3,126	916	3,440	1,008	2.50	8.0
300	900	264	938	275	1.00	10.0
	939	275	1,250	366	1.25	8.0
	1,251	367	1,875	550	1.50	10.0
	1,876	550	3,125	916	2.00	10.0
	3,126	916	3,750	1,099	2.50	10.0
350	900	264	938	275	1.00	10.0
	939	275	1,250	366	1.25	8.0
	1,251	367	1,875	550	1.50	10.0
	1,876	550	3,125	916	2.00	10.0
	3,126	916	4,380	1,284	2.50	10.0
400	1,750	513	1,875	550	1.50	10.0
	1,876	550	3,125	916	2.00	10.0
	3,126	916	5,000	1,465	2.50	12.0
450	1,750	513	1,875	550	1.50	10.0
	1,876	550	3,125	916	2.00	10.0
	3,126	916	5,000	1,465	2.50	12.0
	5,001	1,466	5,600	1,641	2.50	15.0

FIGURE 58: Manifold Diagram for Gas-Fired Air Handler with any FM-Compliant Manifold/XL-Compliant Manifold Rated for Less Than 1,000 MBH (293 kW) and with On/Off or High/Low/Off Burners

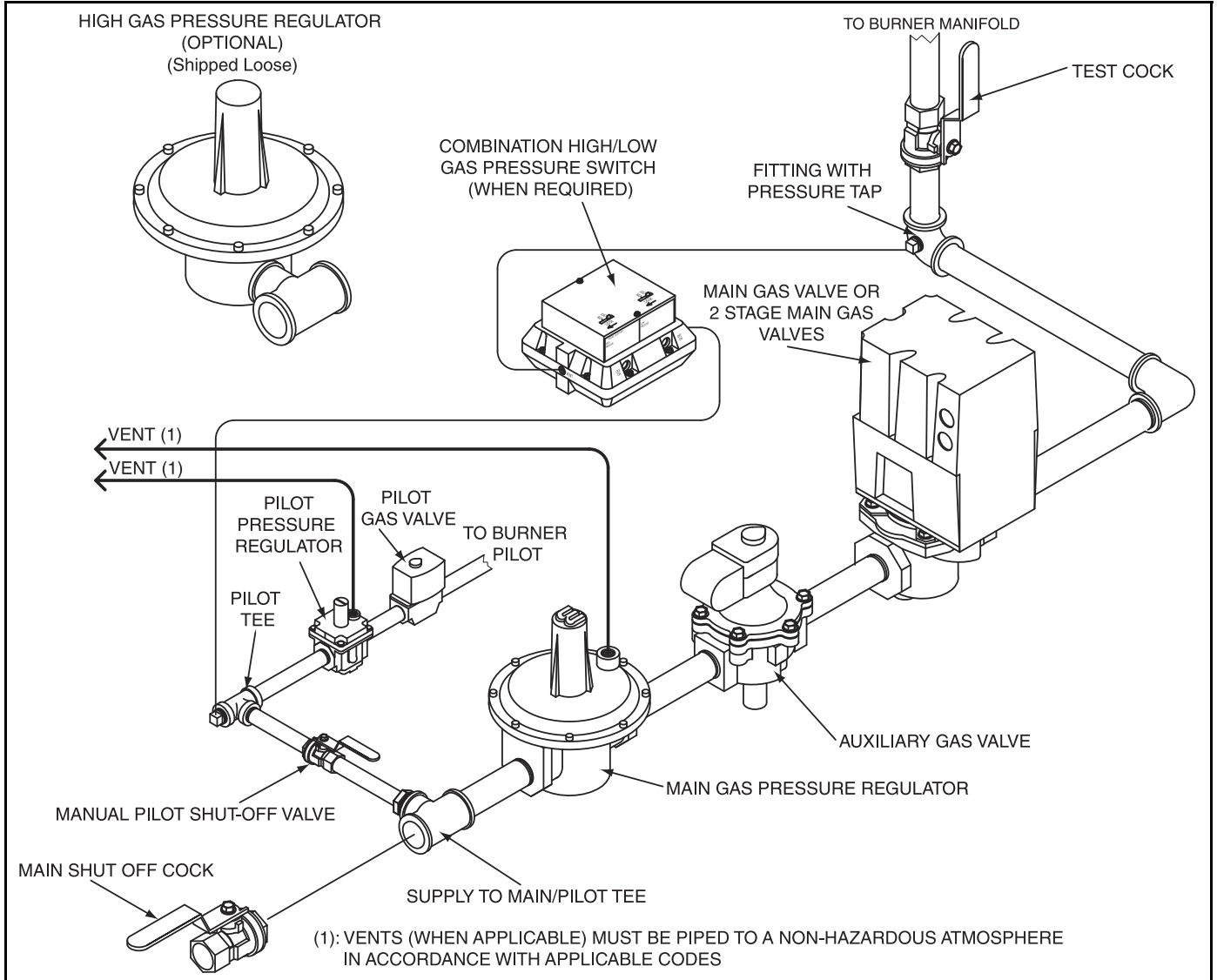

FIGURE 59: Manifold Diagram for Gas-Fired Air Handler with any FM-Compliant Manifold/XL-Compliant Manifold Rated for Less Than 1,000 MBH (293 kW) and with Modulating Burner

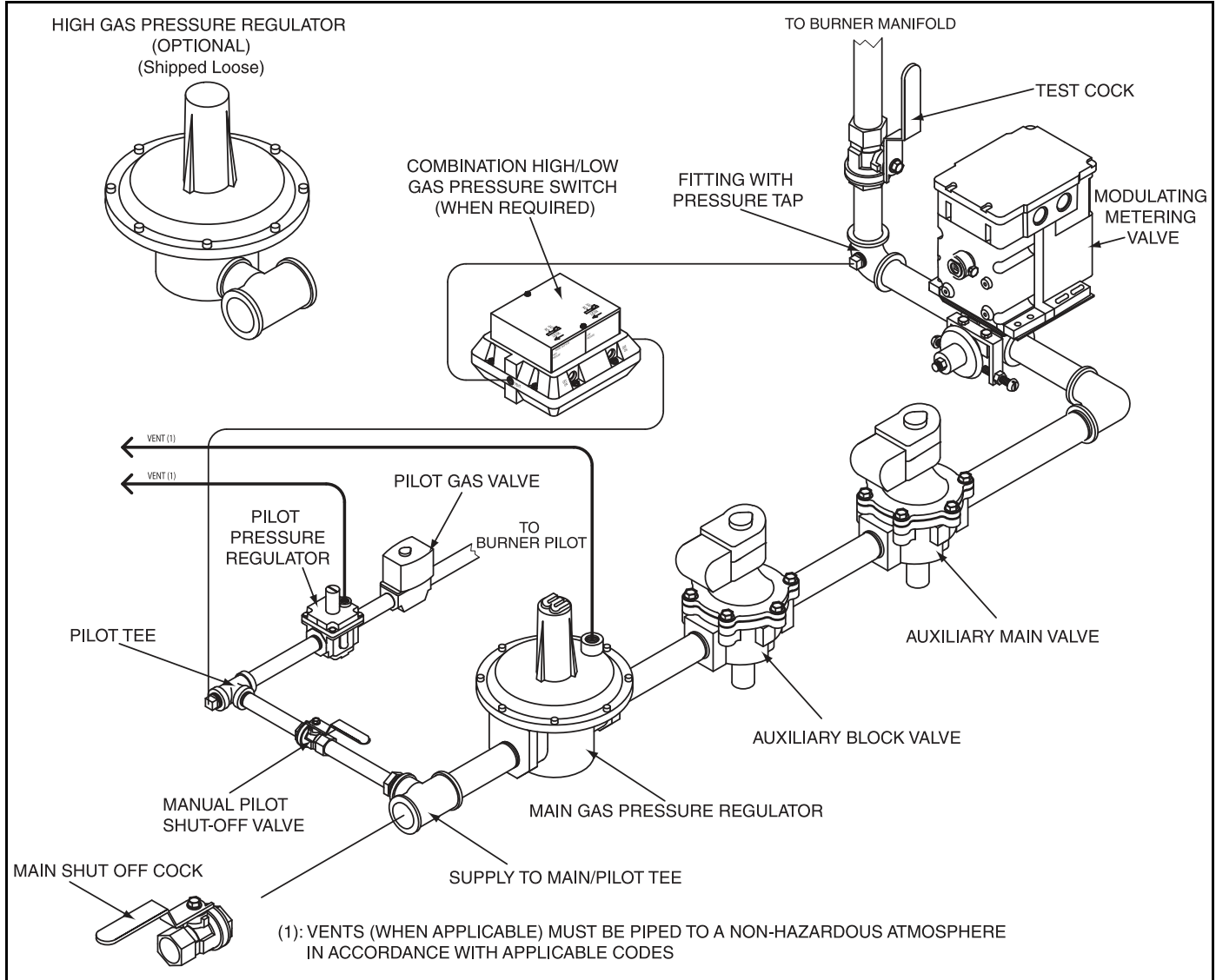

FIGURE 60: Manifold Diagram for Gas-Fired Air Handler with XL-Compliant Manifold Rated for More Than 1,000 MBH (293 kW) and with On/Off or High/Low/Off Burner

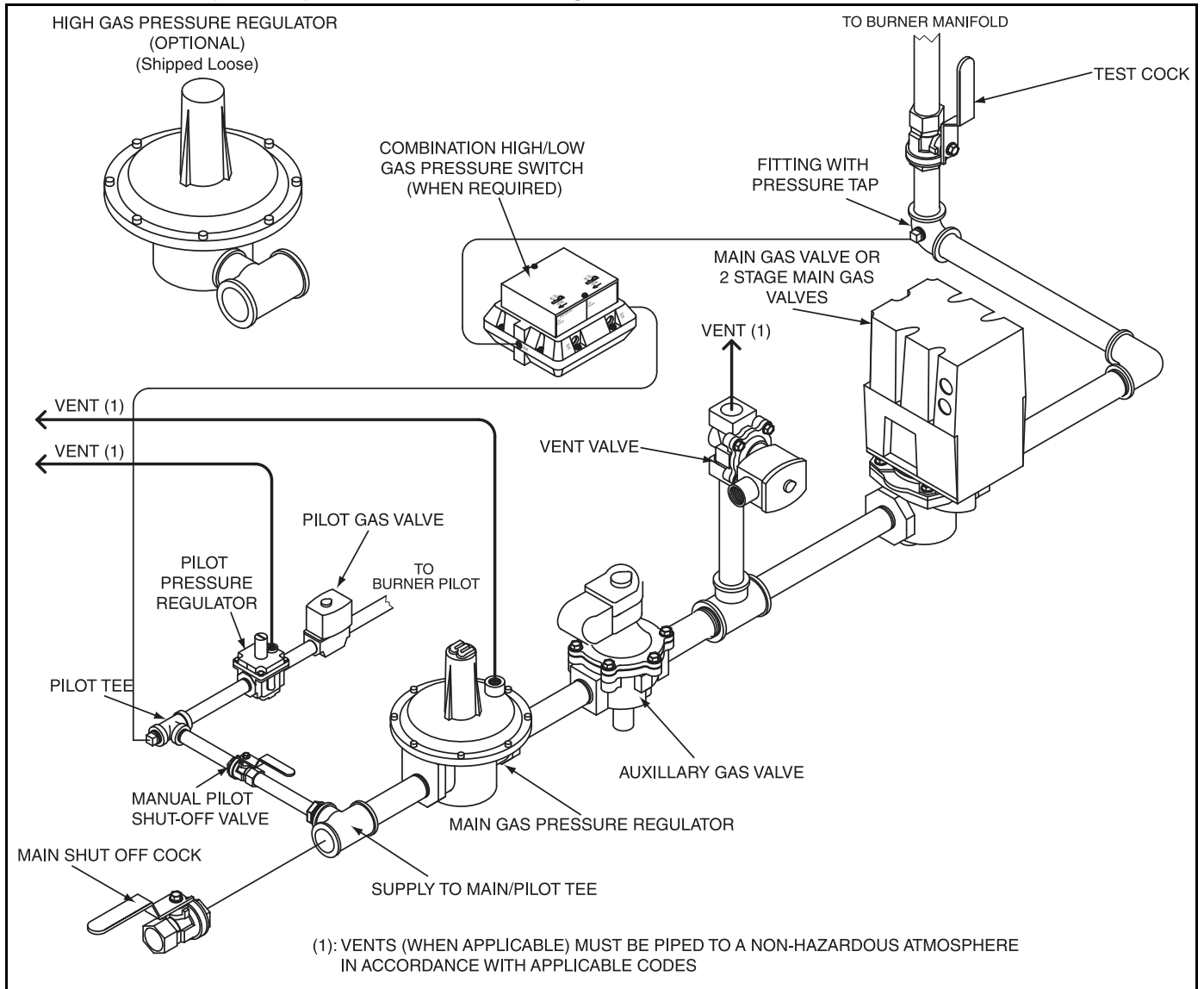
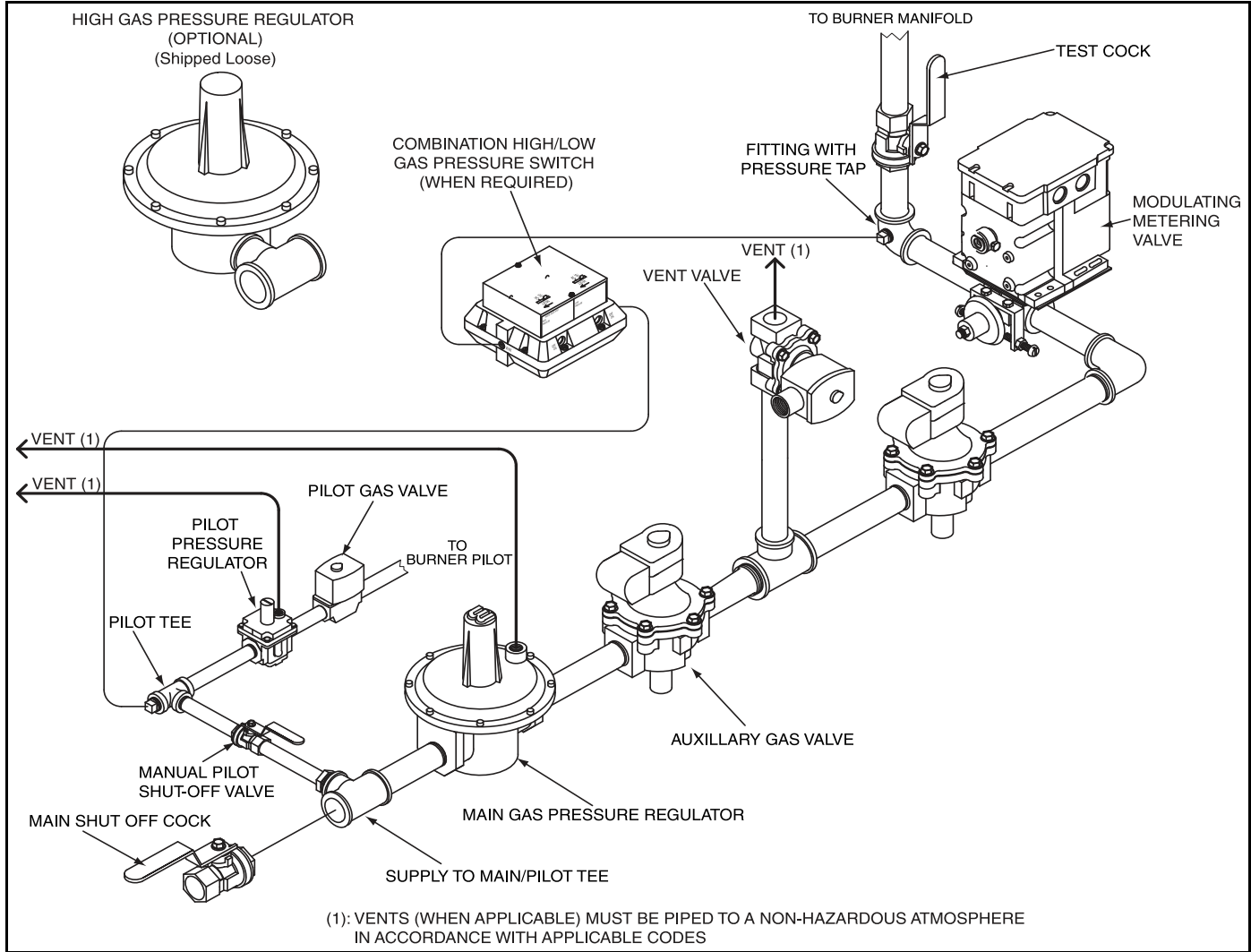

FIGURE 61: Manifold Diagram for Gas-Fired Air Handler with XL-Compliant Manifold Rated for More Than 1,000 MBH (293 kW) and with Modulating Burner



20.3 Gas Manifold Venting

Vent valves fitted on XL-compliant manifolds must be piped to the atmosphere outside the structure. This is the responsibility of the installer.

20.3.1 Main Gas Regulator Venting

The main regulator used on 1 ¼" and larger manifolds must be piped to the atmosphere outside the structure. This is the responsibility of the installer.

20.3.2 Vent Line Installation

The following may be used as a guideline for installation, but all applicable codes and regulations must be followed.

- Natural gas and LPG are toxic and flammable substances. They must be released where they will not cause personal injury or property damage. The end of the vent line must be located where it is safe to release gas.
- Pipe the vent line outside the structure.
- Use as short a vertical run of pipe as possible.
- Do not run pipe from a high point to a lower point to avoid obstacles.
- Use a minimum number of bends.
- Do not downsize the pipe from the origination point (must be same size or larger).
- Make sure vent line is free from obstructions.
- Do not group lines together into a common header.
- The outside termination must have a weatherproof cap or be directed downward for protection from the elements and must be screened to prevent the entry of any objects.

20.4 Gas Piping

The factory piping terminates with a female pipe connection in the pilot take off tee. The manual main gas shutoff valve is shipped loose for field installation. The gas manifold must be extended through the side of the control cabinet where the main shutoff valve is installed. Be sure that the fuel supply pipe connected at this point is large enough to ensure the proper gas flow and line pressure at the inlet of the unit. The piping must comply with:

United States: Refer to NFPA 54/ANSI Z223.1 - latest revision, National Fuel Gas Code.

Canada: Refer to CSA B149.1 - latest revision,

Natural Gas and Propane Installation Code.

Gas supply piping must conform to best building practices and local codes. During installation of the gas piping, be sure that no piping restricts accessibility to the air handler or its removable access doors.

Lockable manual shut-off valve must be added by the installer in compliance with Occupational Safety and Health Administration (OSHA) regulations.

20.5 Pressure Test Ports

There are 3/8" and 1/4" pressure test ports located on the manifold. The test ports are available to measure the manifold inlet gas pressure and the burner gas pressure during burner setup.

20.5.1 Manifold Inlet Gas Pressure - 3/8" NPT

The pressure test port for measuring manifold inlet pressure is located on the pilot tee which is located on the manifold inlet tee. Refer to the air handler rating plate for the acceptable inlet gas pressure. See *Page 83, Figure 62*.

FIGURE 62: Test Port Location

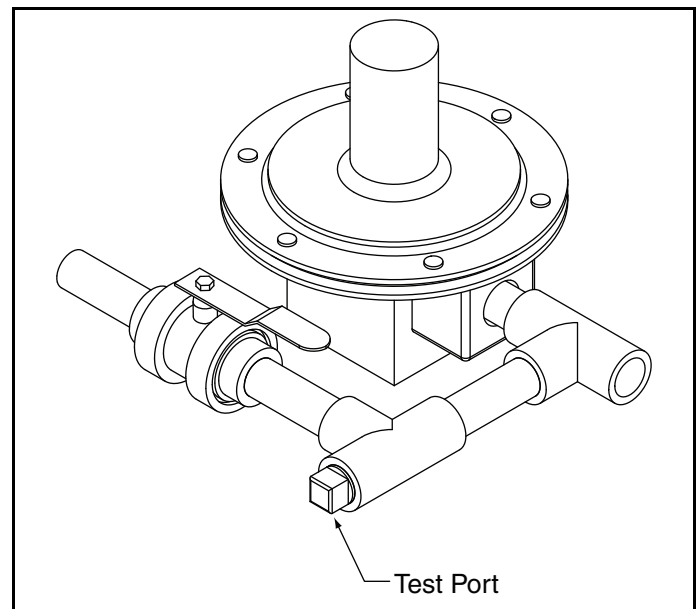

20.5.2 Burner Gas Pressure - 1/4" NPT

The pressure test port for measuring burner gas pressure is located at the burner inlet orifice tee. Refer to the air handler rating plate for the burner pressure required for high fire. See *Page 84, Figure 63*.

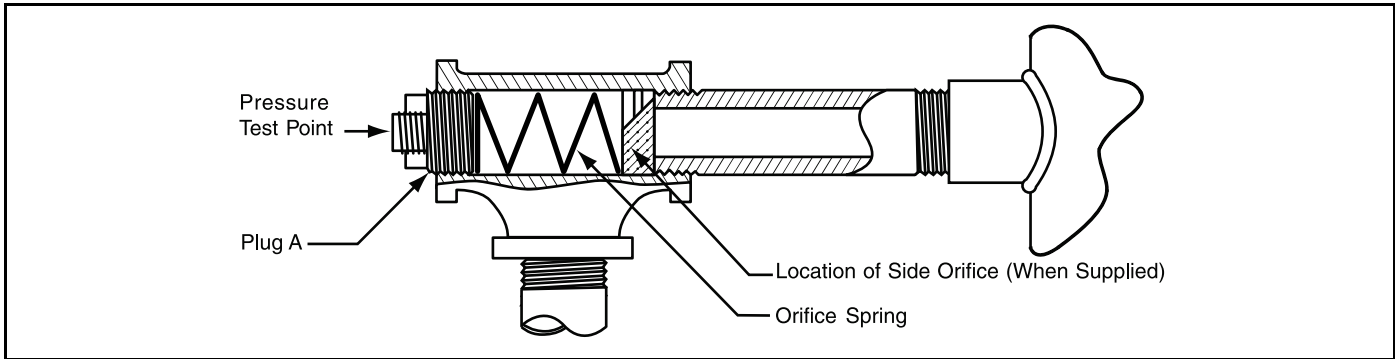
FIGURE 63: Location of Side Orifice

20.6 Line Pressure Test - Leak Testing

The air handler and its individual shut-off valve must be disconnected from the gas supply piping systems during any pressure testing of that system at test pressures in excess of 1 PSIG (68.9 mbar). The air handler must be isolated from the gas supply piping system by closing its individual manual gas valve that is located immediately upstream of the safety shut-off gas valve.

SECTION 21: OIL PIPING FOR OIL-FIRED AIR HANDLERS

⚠ WARNING

Explosion Hazard
Leak test all components of gas/oil piping before operation.
Gas/oil can leak if piping is not installed properly.
Do not high pressure test gas/oil piping with air handler connected.
Failure to follow these instructions can result in death, injury or property damage.

All oil piping to the air handler must comply with:

United States: Refer to NFPA 31 - latest revision, Standard for the Installation of Oil Burning Equipment.

Canada: Refer to CSA B139 - latest revision, Installation Code for Oil Burning Equipment.

The air handlers are available with two different types of manifolds:

- Factory Mutual (FM)/Underwriters Laboratories (UL) Compliant
- XL Insurance (former IRI) Compliant

21.1 Oil Piping and Pressures

Do not use any sealant whether paste or tape that contains Teflon™ on the pipe or fittings. Teflon™ will cause valves to fail and block nozzles.

The burners utilized on the air handler are designed for a two-pipe oil system for Number 1 and 2 fuel oil. See Page 85, Figure 64. Systems designed for a two-pipe system can not be used with a one-pipe system.

FIGURE 64: Two-Pipe Oil System

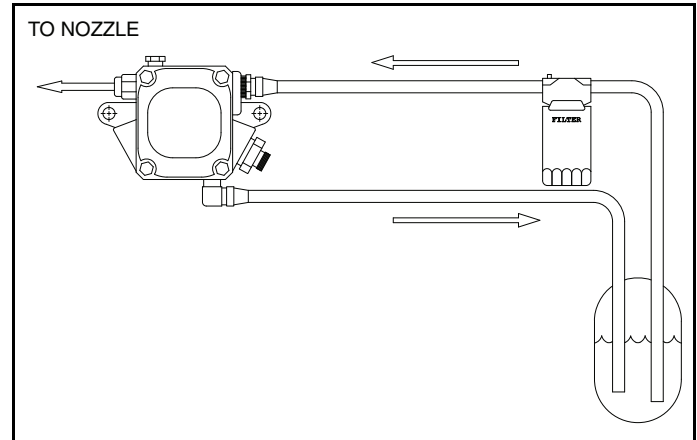

The maximum pressure allowable on the suction side of the pump is 3 PSIG (137.9 mbar) static and 2 PSIG (206.8 mbar) operating. The maximum vacuum allowable on the suction side of the pump is 10" HG.

There is no factory piping for the suction line or return line for the oil supply as they are located on the burner's pump. See Page 86, Figure 65 through Page 86, Figure 66. The size of the suction line is dependent on the type of oil, amount of lift, length of suction line and the pump capacity. On single air handler installations, the return line should be the same size as the suction line. On multiple air handler installations, each unit must have its own individual suction line, but one return line may be used if it is appropriately sized to handle the flow of all the air handlers.

A hand shut off valve must be provided by others in the suction line near the burner along with a filter. Shut-off valves must not be installed in the return line unless required by a specific code and even then, only if an automatic relief valve is installed across this shut-off valve to allow oil to bypass directly back to the tank if the valve is inadvertently left in the closed position. Use copper tubing with flare fittings or iron pipe on all installations.

The piping must comply with:

United States: Refer to NFPA 31 - latest revision, Standard for the Installation of Oil Burning Equipment.

Canada: Refer to CSA B139 - latest revision, Installation Code for Oil Burning Equipment.

Oil supply piping must conform to best building practices and local codes. During installation of the oil piping, be sure that no piping restricts accessibility to the air handler or its removable access doors.

21.2 Line Pressure Test - Leak Testing

The air handler and its individual shut-off valve must be disconnected from the oil supply piping systems during any pressure testing of that system at test pressures. The air handler must be isolated from the oil supply piping system by disconnecting the supply and return pipe from the pump. Only use air or nitrogen to leak test the piping.

FIGURE 65: Suntec Two Step Pump

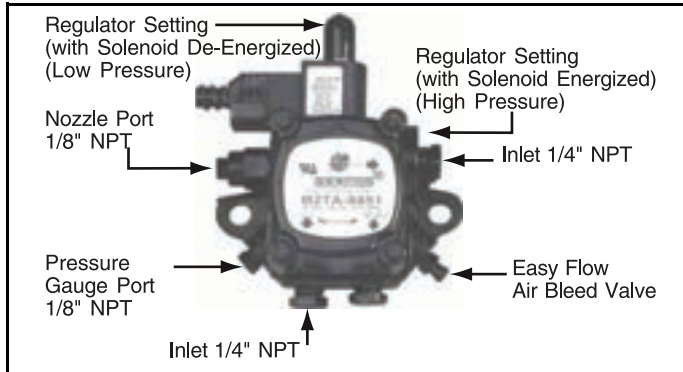
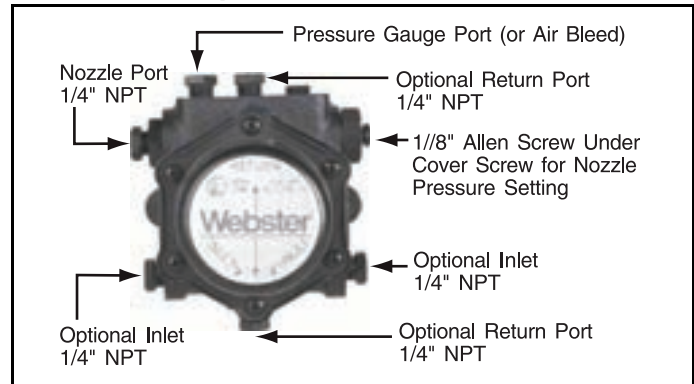

FIGURE 66: Webster 3450 RPM Blower Motor Driven Oil Pump



21.3 Pressure Test Ports

There are pressure test ports located on the burner's pump. The test ports are available to measure the nozzle pressure and bypass pressure (if so equipped). See Page 86, Figure 65 through Page 86, Figure 66. The Suntec pump is typically used for On/Off and High/Low/Off burners up to 23 GPH (87.1 LPH). The Webster pump is typically used for On/Off and High/Low/Off burners above 23 GPH (87.1 LPH) and all fully-modulating burners.

21.4 Oil Manifolds

FIGURE 67: FM or XL-Compliant Manifold for Air Handlers with Suntec Pump and On/Off Burner

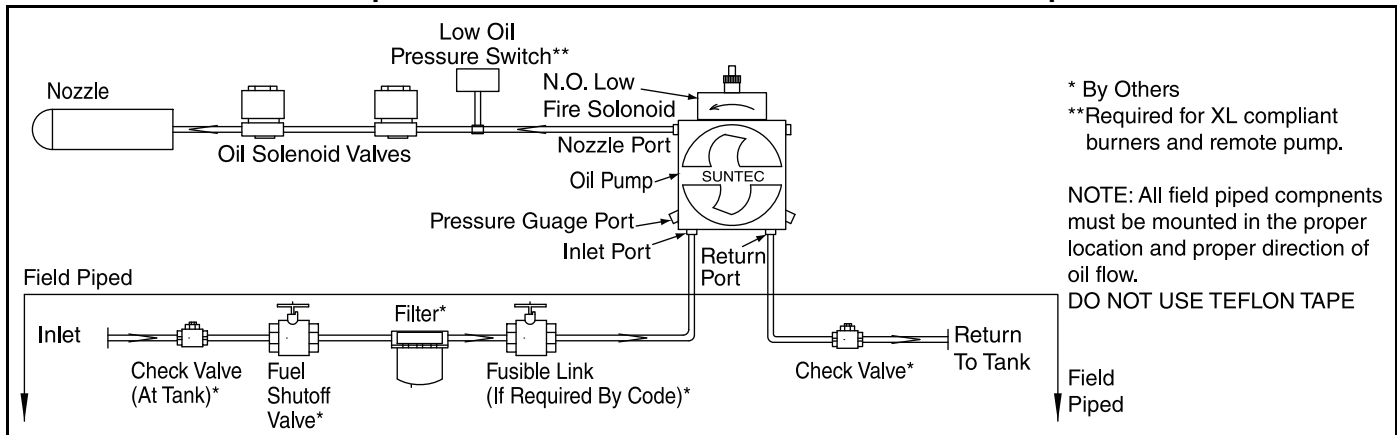

FIGURE 68: FM or XL-Compliant Manifold for Air Handlers with Suntec Pump and High/Low/Off Burner

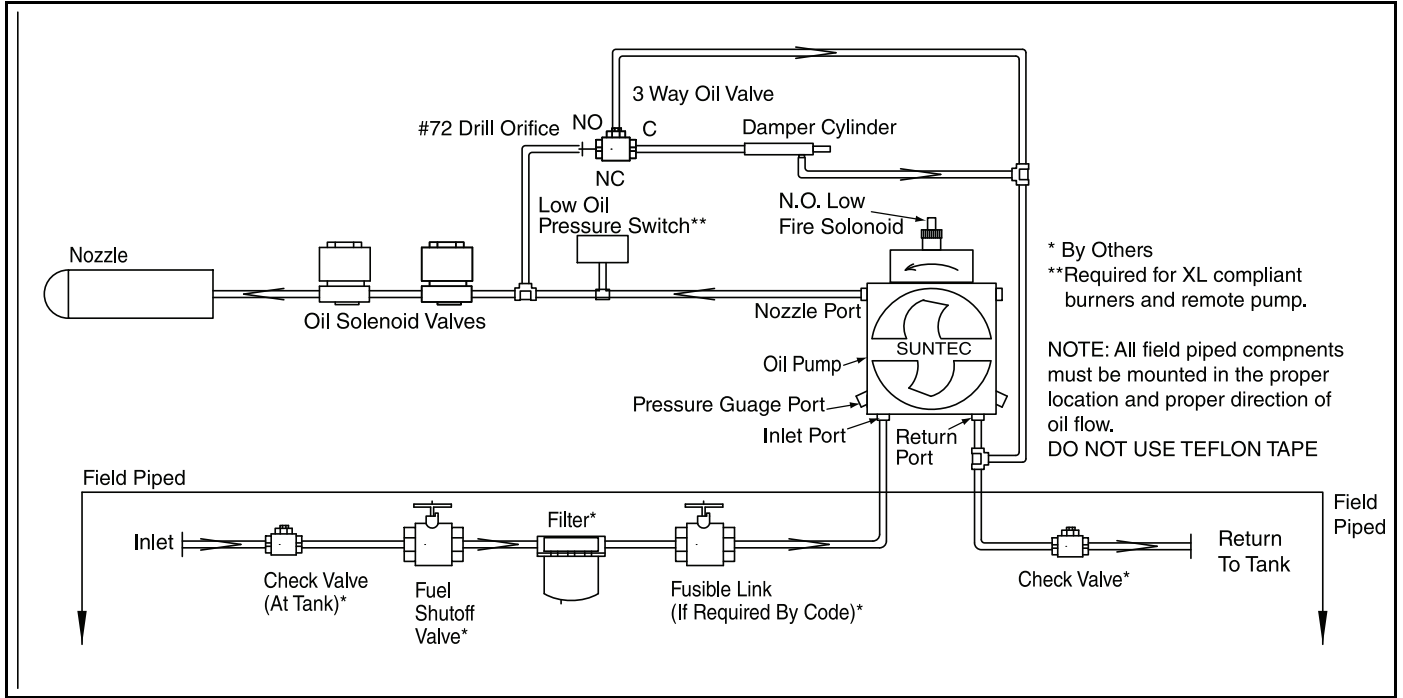

FIGURE 69: FM or XL-Compliant Manifold for Air Handlers with Webster Pump and High/Low/Off Burner

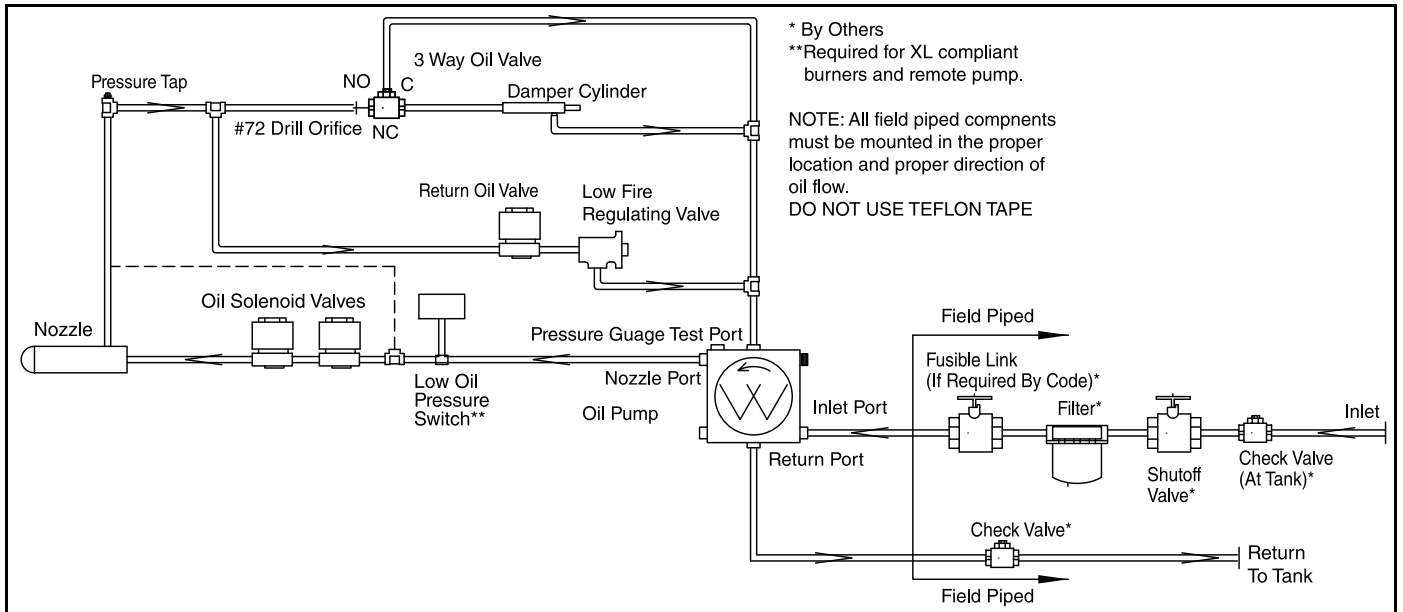
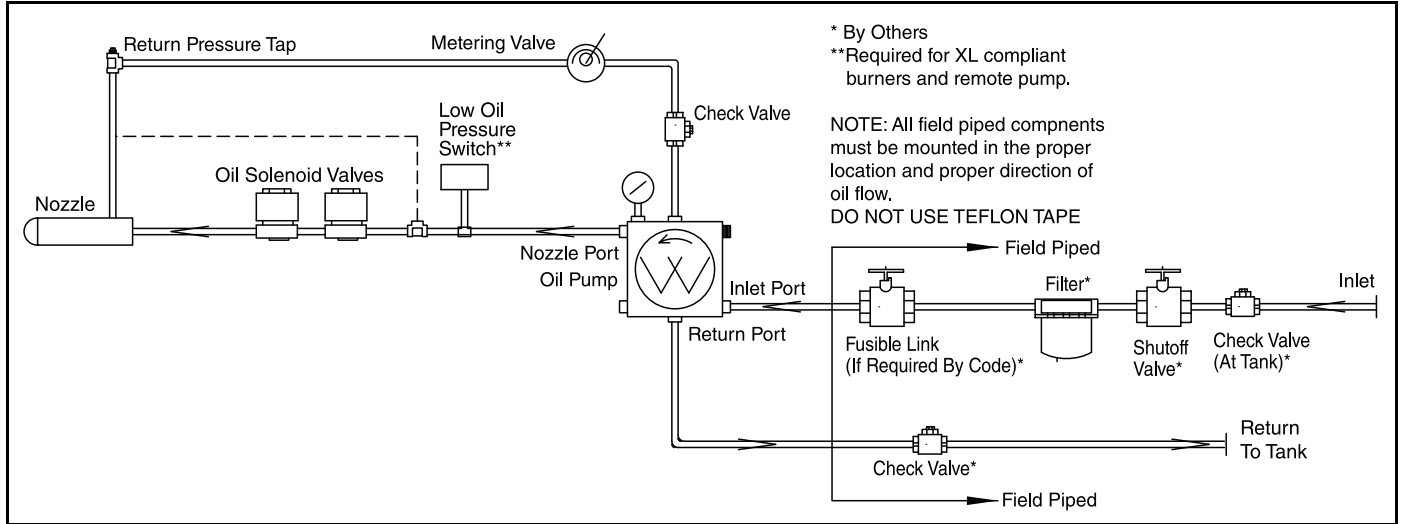

FIGURE 70: FM or XL-Compliant Manifold for Air Handlers with Webster Pump and Fully-Modulating Burner



SECTION 22: COMBINATION GAS AND OIL BURNERS

⚠ WARNING**Explosion Hazard**

Leak test all components of gas/oil piping before operation.

Gas/oil can leak if piping is not installed properly.

Do not high pressure test gas/oil piping with air handler connected.

Failure to follow these instructions can result in death, injury or property damage.

Burners are available that burn both natural gas/LPG and oil. They have an independent manifold and ignition system for each fuel. They share the flame safeguard control and control linkage - See Page 89, Figure 71.

FIGURE 71: Typical Linkage for a Combination Gas/Oil Burner

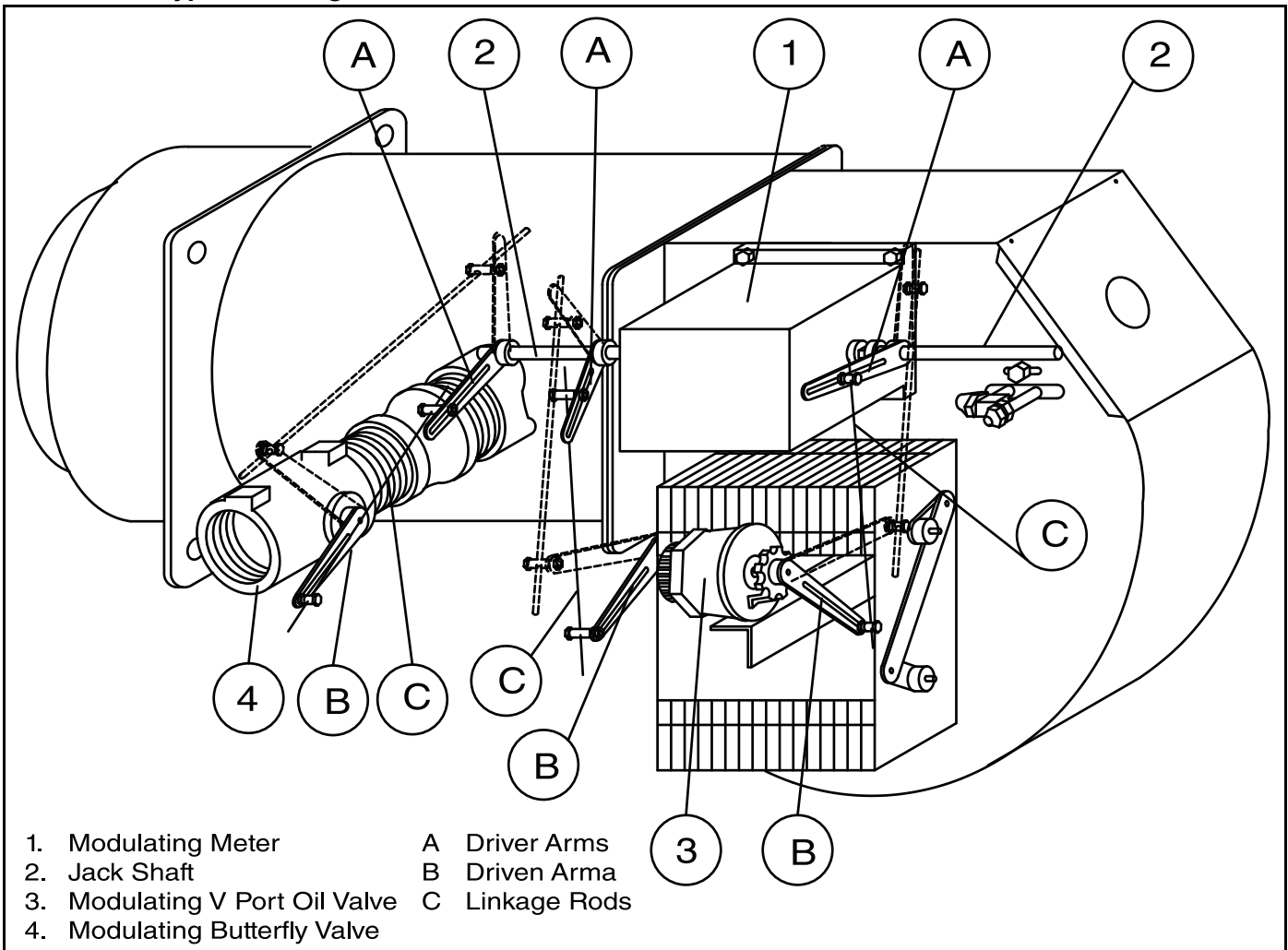

22.1 Switching Between Fuels

There are two methods of switching between natural gas/LPG and oil. The first method is the semi-automatic changeover (standard equipment offering) and the second is fully automatic changeover (optional equipment offering).

22.2 Semi-Automatic Change Over

In this standard method, a fuel transfer switch (located on the burner) will energize the appropriate manifold and ignition systems. Because proper oil flow to the pump can not be guaranteed, the pump must either be manually connected in the burner (when switching from gas to oil) or disconnected

(when switching from oil to gas). Failure to do this can result in pump failure. To connect/disconnect the pump, the connection coupling is located inside of the burner and connects the input shaft of the pump to the output shaft of the burner blower motor. See *Page 90, Figure 72*.

To disable the oil pump, access the coupling through the access panel of the burner. Using a 1/8" allen wrench, loosen the screws (located one at each end) holding the coupling to the shafts. Slide the coupling towards the pump, which removes it from the blower shaft. Retighten the screw holding it to the pump shaft. Reverse the procedure to reconnect the pump.

FIGURE 72: Burner Oil Pump Shaft Coupling Location

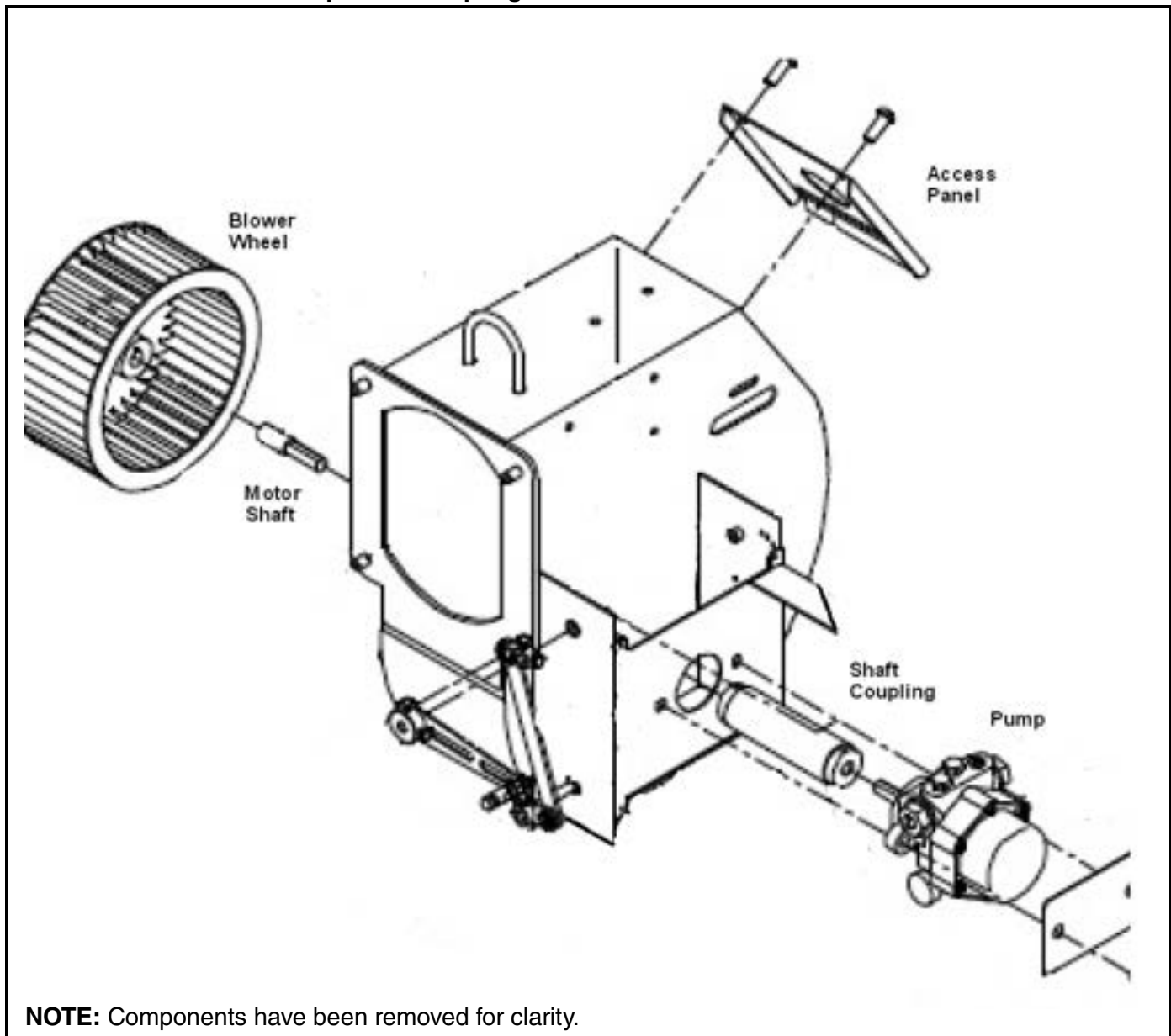

22.3 Fully-Automatic Change Over

In this optional method, a fuel transfer switch (located on the burner) will energize the appropriate manifold and ignition systems. The oil pump, mounted remotely from the burner and equipped with its own drive motor, does not require manual connection/disconnection. See *Page 91, Figure 73*. This pump assembly is mounted adjacent to the burner and is factory piped to the burner assembly.

FIGURE 73: Remote Oil Pump



SECTION 23: ELECTRICAL

⚠ DANGER



Electrical Shock Hazard

Disconnect electric before service.

More than one disconnect switch may be required to disconnect electric from equipment.

Equipment must be properly grounded.

Failure to follow these instructions can result in death or electrical shock.

Each air handler is equipped with a wiring diagram which will vary depending on the type of controls and options supplied.

Note: Spark testing or shorting of the control wires by any means will render the transformers inoperative.

23.1 Wiring and Electrical Connections

All electrical wiring and connections, including electrical grounding, must comply with;

United States: Refer to National Electrical Code®, NFPA 70 - latest revision. Wiring must conform to the most current National Electrical Code®, local ordinances, and any special diagrams furnished.

Canada: Refer to Canadian Electrical Code, CSA C22.1 Part 1 - latest revision.

Check rating plate on air handler for supply voltage and current requirements.

If any of the original control wire supplied with the air handler must be replaced, replace it with type THHN 221° F (105°C), 600 V, 16 gauge wire or equivalent. For all other wires, replace with the equivalent size and type of wire that was originally provided with the air handler.

23.2 Remote Panel

All power supply and motor wiring must be type THWN - or equivalent, minimum with a 167° F (75° C) temperature rise. For wire gauge sizes, See Page 92, Table 21.

23.2.1 Remote Panel Mounting Distance

If the interconnection wiring between the remote panel and the air handler control enclosure is run in a single conduit, the wire run can be as long as 200' (60.9 m). For longer wire runs, consult the factory. Care should be used to avoid running the interconnect wiring near large industrial loads or high voltage wire runs as that may further limit the length of the interconnect wire run.

Table 21: Control Voltage Wiring For All Control Systems

VOLTS	WIRE GAUGE	WIRE FEET
120	18	150
120	16	250
120	14	350

NOTE: Wiring for temperature controls must be run in shielded cable as indicated on the wiring diagram.

23.2.2 Low Voltage Control Wiring

Low voltage (24V - AC/DC) control wiring in excess of 100' (30.5 m) in length should be in its own separate conduit run to prevent interference.

23.3 Motor Current Draw

For current requirements of the motor, see rating plate located on the blower motor.

23.4 Control Current Draw

The maximum current draw for an air handler's controls and accessories is 4.5 A.

23.5 Safety Systems

Safety systems are required for proper performance of the air handler. The air handler shall not be permitted to operate with any safety system disabled. If a fault is found in any of the safety systems, then the system shall be repaired only by a contractor qualified in the installation and service of indirect fired heating equipment, using only components that are sold and supplied by Roberts-Gordon LLC. See Page 93, Table 22 for a brief description of each safety device, its location and its switching voltage.

Table 22: Safety Systems

Safety Controls	Location	Voltage
Fan / Limit Switch	Air Handler Control Enclosure	120
Auxiliary Manual Reset High Temperature Limit Switch	Air Handler Control Enclosure	120
Cabinet Airflow Switch	Air Handler Control Enclosure	120
Gas Pressure Switches	Air Handler Gas Train	120
Flame Control	Air Handler Control Enclosure	120

23.5.1 Fan / Limit Switch

The fan / limit switch acts as a blower control and a high temperature control. It combines the function of a high temperature limit control with that of a fan controller. It has two control relays: one controls the air handler's blower and the other acts as a high temperature controlling relay. The fan relay has two settings or set points - one for turning on the air handler's blower and one for turning it off. The limit's relay only has one set point.

The fan portion of the switch has its set point set at 120° F (48.8° C). After the air surrounding the heat exchanger reaches set point, the fan relay closes and power is supplied to the air handler's blower motor starter coil, which turns the blower motor on if it is not already running. If the sensor for the fan relay cools down below its set point (based on the second set point), it will open shutting down the air handler's blower if required. The second set point for the fan portion of the switch is labeled "HYS" which stands for Hysteresis. This is the degrees below the fan set point at which the relay will open. A setting of 15° F (8.3° C) is recommended for this equipment.

Note: This feature of the fan/limit switch could cause the air handler's main blower to cycle on and off a number of times after a heating cycle ends to cool down the heat exchanger. This could continue even with other controls turned off. Only turning off the main power disconnect will disable the feature.

The limit portion of the switch has its set point set at 200° F (93.3° C). After the air surrounding the heat exchanger reaches set point, the limit relay will open the circuit to the burner system and discontinue all burner functions. Restarting of the burner can only be accomplished after the sensor for the limit has cooled down below its set point.

23.5.2 Auxiliary Manual Reset High Temperature Limit Switch

If for any reason, the temperature of the air

surrounding the heat exchanger reaches the limit set point of 250° F (121.1° C), the high temperature limit switch will open the circuit to the air handler's control system and shut it down. Restarting of the burner can only be accomplished after the limit has cooled down and the reset button on the switch is depressed.

23.5.3 Pressure Switches

23.5.4.1 Cabinet Airflow Switch

The cabinet airflow switch monitors the airflow through the blower section of the air handler; its function is to protect the air handler and downstream components from improper low airflow conditions. The burner is allowed to function via the warm-up bypass timer contacts even though the blower may not be running. Once the air handler's blowers are turned on the air handler's airflow switch closes and the warm-up bypass timer completes its time out cycle, removing the bypass circuit. This only allows the burner to function as long as airflow is present throughout the air handler (except during warm-up).

This airflow switch is adjusted by turning the adjustment screw clockwise, till the screw is two turns from flush of its housing.

23.5.5.2 Gas Pressure Switches

Gas pressure switches are standard on certain models (UL & FM compliant gas trains above 2,500 MBH and XL compliant gas trains above 400 MBH) and are also available as an option on the others. The version used combines the function of both into one component.

The function of the gas pressure switches is to protect against insufficient, lack of gas pressure and excessive pressure in the system.

On the low gas pressure switch side, this switch opens its internal switch which shuts the burner down and prevents its operation due to insufficient gas pressure.

On the high gas pressure switch side, its internal switch will open, shutting down the burner due to excessive gas pressure passing through the gas train.

The settings of the gas pressure switches are field adjustable. The one monitoring the incoming gas pressure is the low gas pressure switch. The low gas pressure switch must be set to the minimum required gas pressure as indicated on the data plate.

The high gas pressure switch must be set to 1" wc (2.5 mbar) above the high fire setting established

during commissioning.

If either switch senses a pressure which is lower (low gas pressure switch) or higher (high gas pressure switch) than its set point, then the switch will open and lock out, shutting the burner down. The switch will have to be reset manually, once the condition has been corrected.

23.5.6 Flame Control

This device will check for both pilot flame and main flame (main flame only on oil fired equipment) within the burner. When a flame signal from the pilot flame is available (on gas-fired equipment), it will allow the main gas valve to open.

If the pilot flame (gas-fired) or the main flame signal (oil-fired) is not present, the electrical signal cannot be continued so the pilot valve (gas-fired) or main valve (oil-fired) will close. If ignition does not occur, the flame safeguard relay will lockout, and must be manually reset. (See the Trouble-Shooting Guide - *Page 162, Section 28.6*)

23.5.7 Discharge Temperature Sensor

This device senses the discharge temperature of the air handler. The discharge temperature sensor reports the discharge temperature to the burner control device. Should this system fail, the automatic and manual high temperature limit switches will turn the burner off. DDC-ready air handlers do not come equipped with this sensor and must be field-supplied.

FIGURE 74: Wiring Diagram Key**NOTES:**

- 1.) DRAWING ONLY PROVIDED TO SHOW FIELD WIRING REQUIRED BETWEEN ELECTRICAL COMPONENTS THAT ARE SHIPPED LOOSE AND AIR HANDLER CONTROL PANEL
- 2.) THIS DRAWING IS NOT INTENDED TO SHOW ELECTRICAL RECONNECT BETWEEN AIR HANDLER SECTIONS. SOME RECONNECT MAYBE REQUIRED BETWEEN SECTIONS SPLIT FOR SHIPMENT.
- 3.) INSTALLER OF FIELD WIRING AND GROUNDING TO COMPLY WITH ALL LOCAL AND NATIONAL ELECTRICAL CODE REQUIREMENTS.
- 4.) USE ONLY COPPER CONDUCTORS FOR FIELD WIRING. CONDUCTORS MUST BE RATED 167° F (75° C) OR GREATER.
- 5.) TERMINALS #60 AND ABOVE ARE DESIGNATED AS LOW VOLTAGE. ALL FIELD WIRING FOR LOW VOLTAGE ARE TO BE RUN IN SEPARATE CONDUIT(S).
- 6.) CONDUCTOR TIGHTENING TORQUE REQUIREMENT.
 - A.) CONTROL TERMINALS @ 12 in/lbs
 - B.) POWER DISTRIBUTION BLOCK
 - LINE SIDE- WIRE SIZE:
 - #2/0 - #6 @ 120 in/lbs
 - #8 @ 45 in/lbs
 - #10 - #14 @ 35 in/lbs
 - LOAD SIDE- WIRE SIZE:
 - #4 - #14 @ 35 in/lbs

KEY:

- TERMINAL LOCATED ON MAIN PANEL
- ▲ TERMINAL LOCATED ON REMOTE PANEL
- TERMINAL LOCATED ON COMPONENT
- f
----- FIELD WIRING
- ||| ○ SHIELDED WIRE GROUNDED
- * LOCATED ON REMOTE PANEL
- ** SHIPPED LOOSE FOR FIELD INSTALLATION

FIGURE 75: Wiring Diagram for Gas-Fired Air Handler with FM-Compliant Manifold and On/Off Burner with Input Less Than 2,500 MBH (732.7 kW)

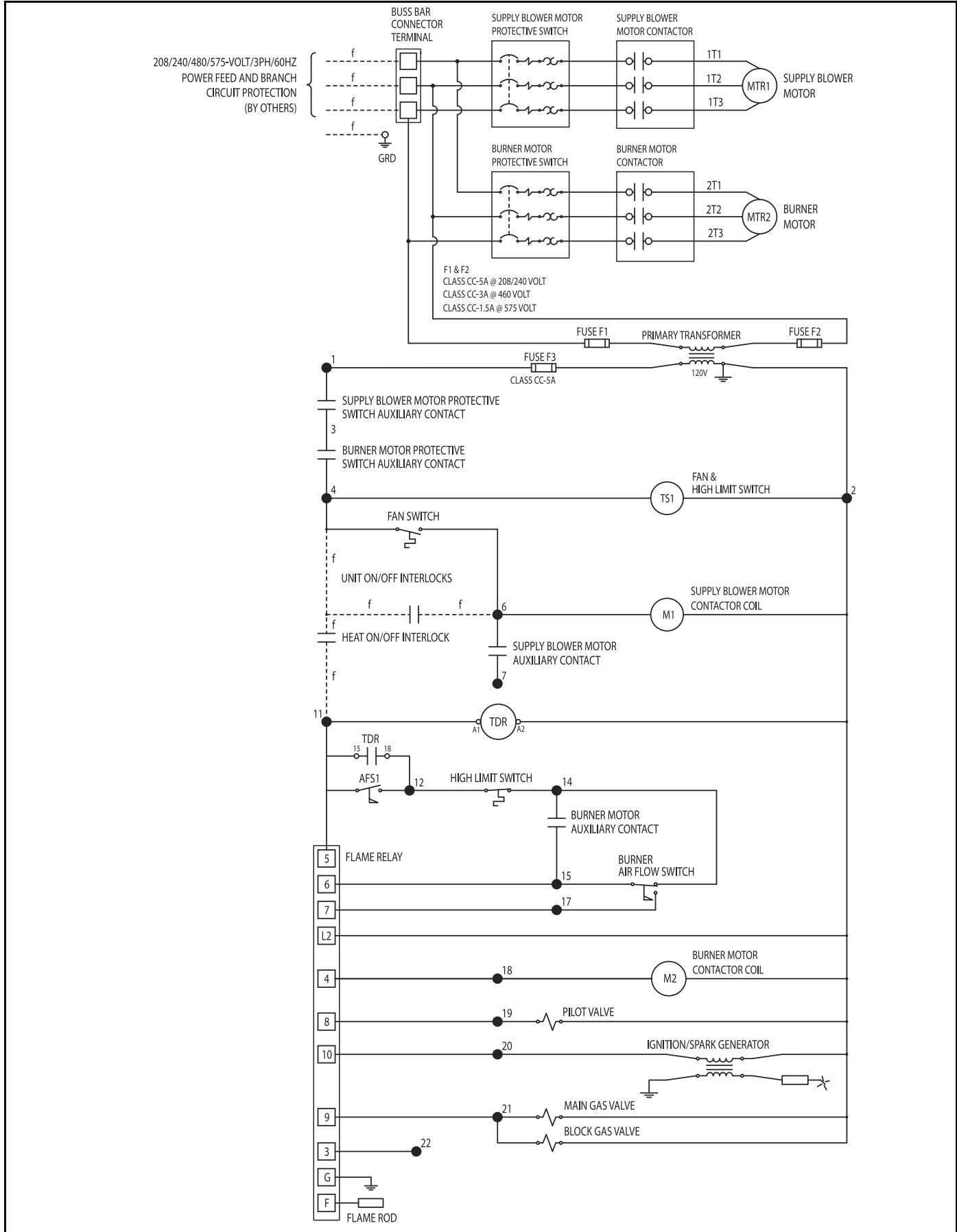

FIGURE 76: Wiring Diagram for Gas-Fired Air Handler with FM-Compliant Manifold and High/Low/Off Burner with Input Less Than 2,500 MBH (732.7 kW)

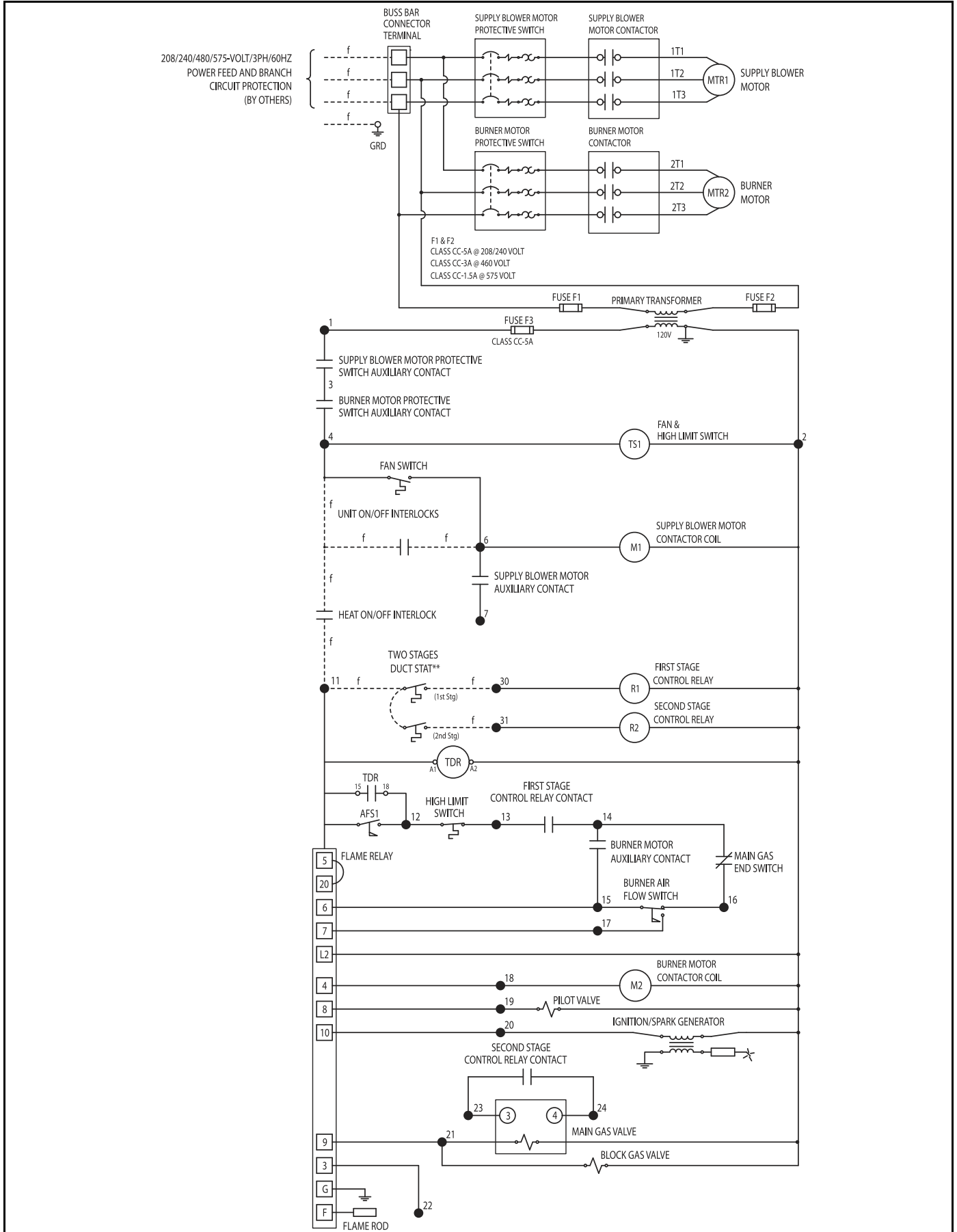

FIGURE 77: Wiring Diagram for Gas-Fired Air Handler with FM-Compliant Manifold and High/Low/Off Burner with Input 2,500 to 5,000 MBH (732.7 - 1465.4 kW)

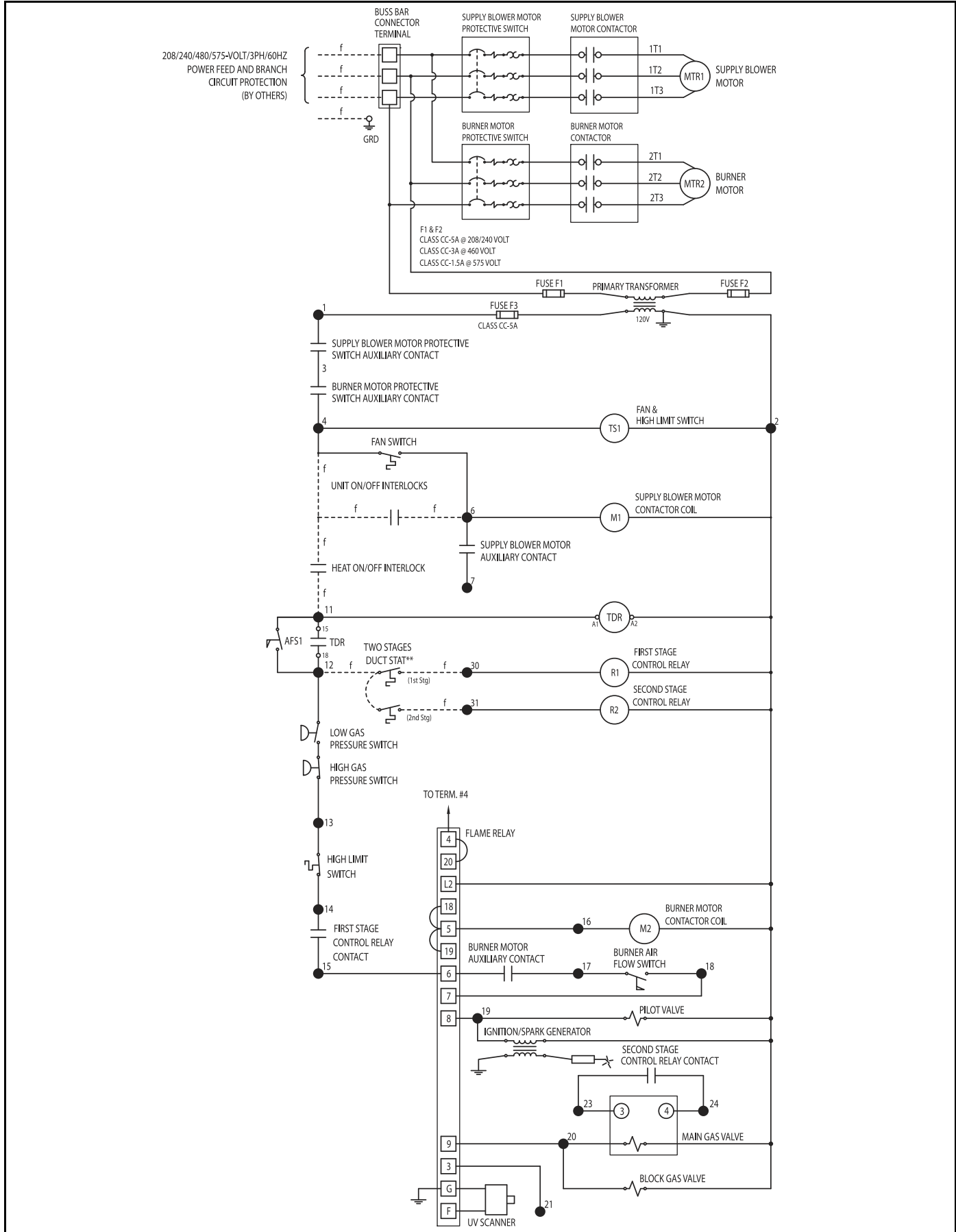

FIGURE 78: Wiring Diagram for Gas-Fired Air Handler with FM-Compliant Manifold and High/Low/Off Burner with Input More Than 5,000 MBH (1465.4 kW)

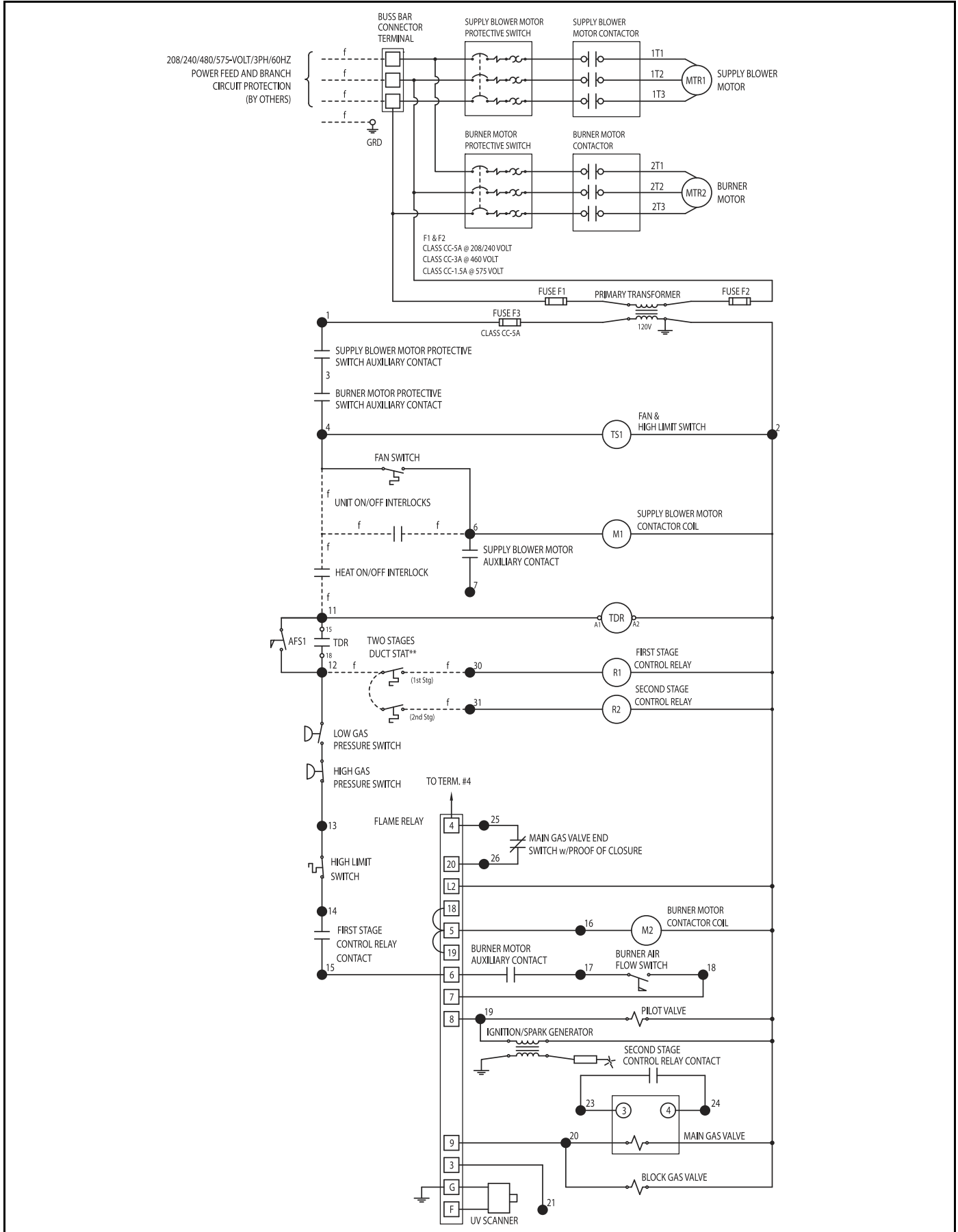

FIGURE 79: Wiring Diagram for Gas-Fired Air Handler with FM-Compliant Manifold and Fully-Modulating Burner with Input Less Than 2,500 MBH (732.7 kW)

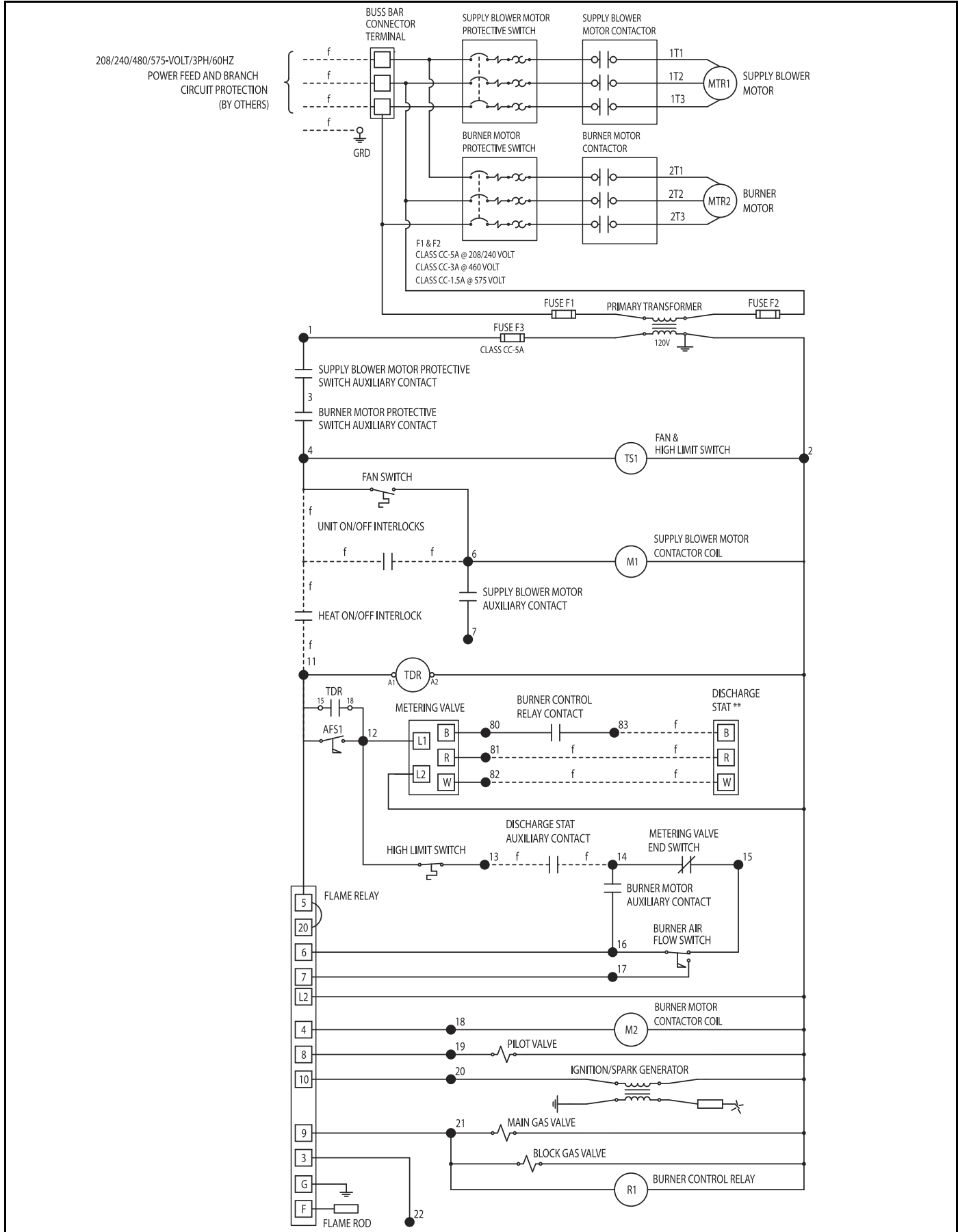

FIGURE 80: Wiring Diagram for Gas-Fired Air Handler with FM-Compliant Manifold and Fully-Modulating Burner with Input 2,500 to 5,000 MBH (732.7 - 1465.4 kW)

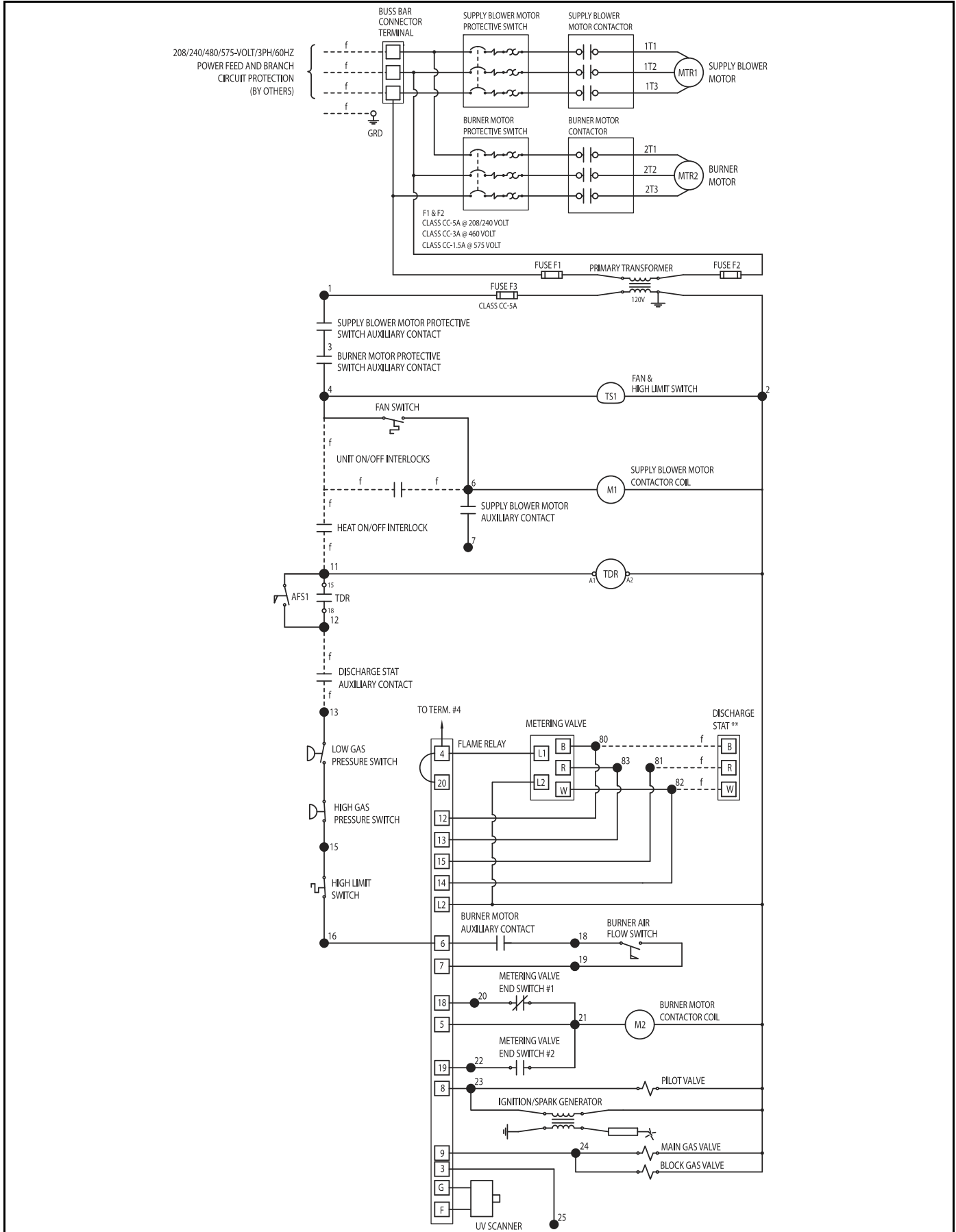

FIGURE 81: Wiring Diagram for Gas-Fired Air Handler with FM-Compliant Manifold and Fully-Modulating Burner with Input More Than 5,000 MBH (1465.4 kW)

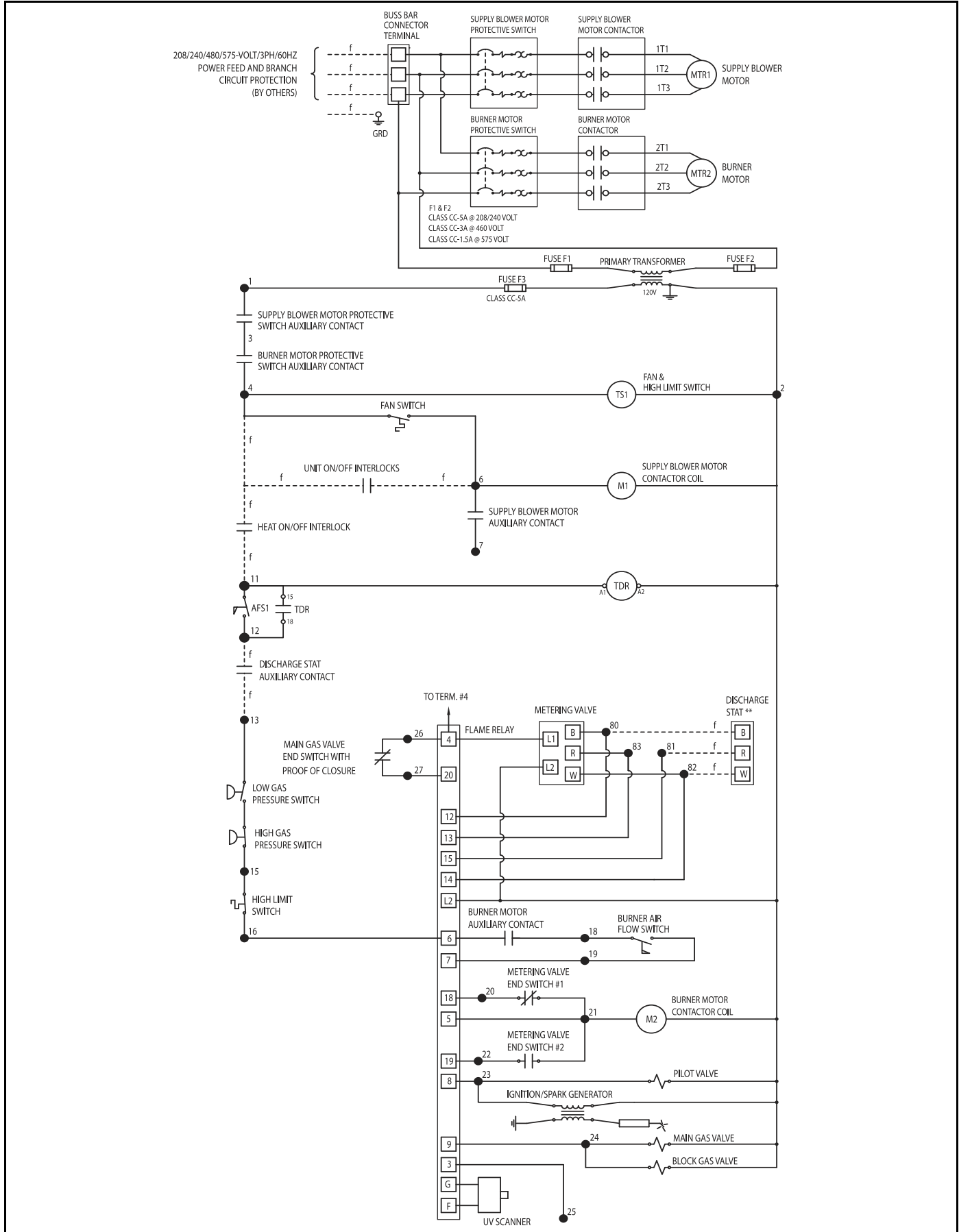

FIGURE 82: Wiring Diagram for Gas-Fired Air Handler with XL-Compliant Manifold and On/Off Burner with Input Less Than 1,000 MBH (293.1 kW)

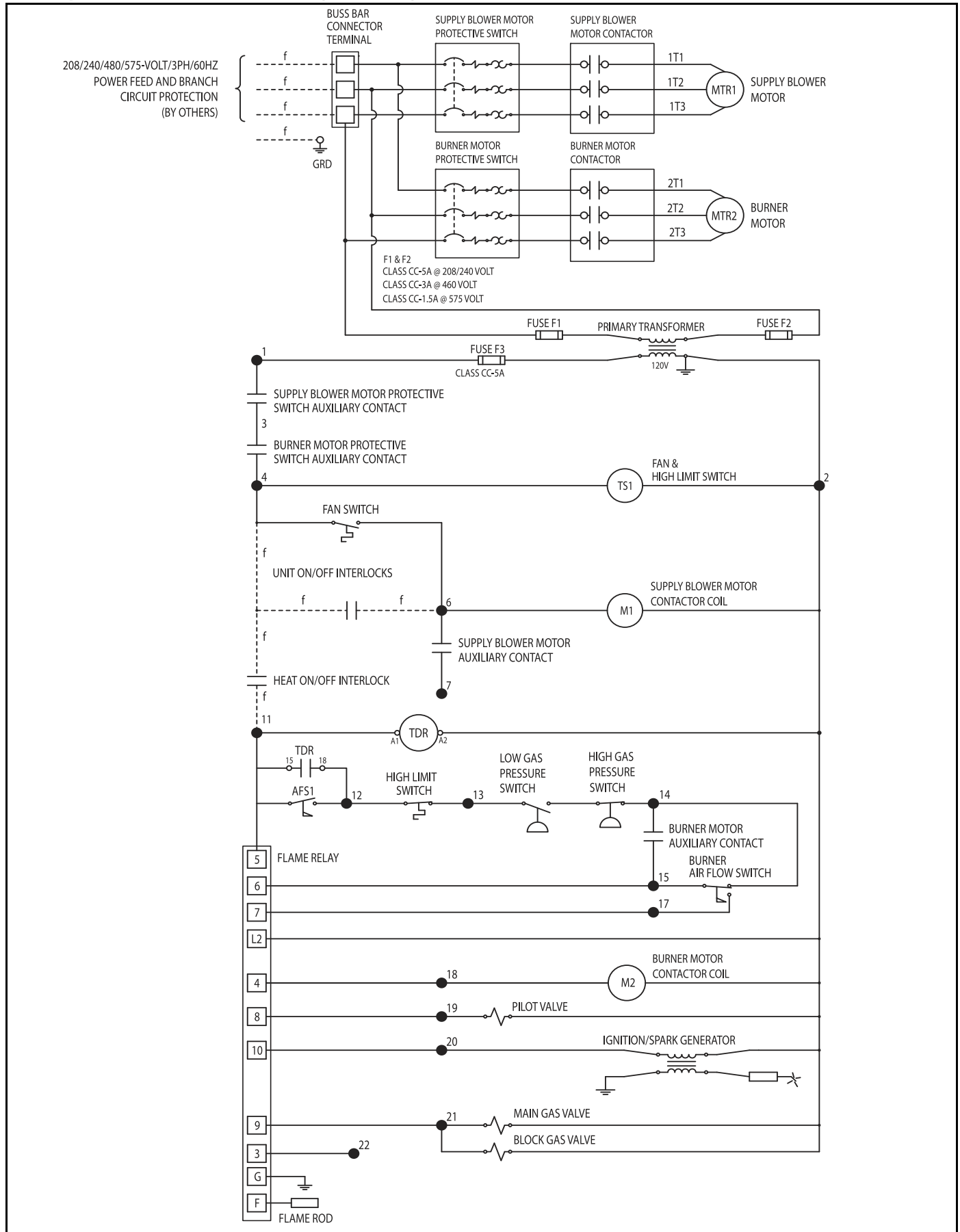

FIGURE 83: Wiring Diagram for Gas-Fired Air Handler with XL-Compliant Manifold and On/Off Burner with Input 1,000 to 2,500 MBH (293.1 - 732.7 kW)

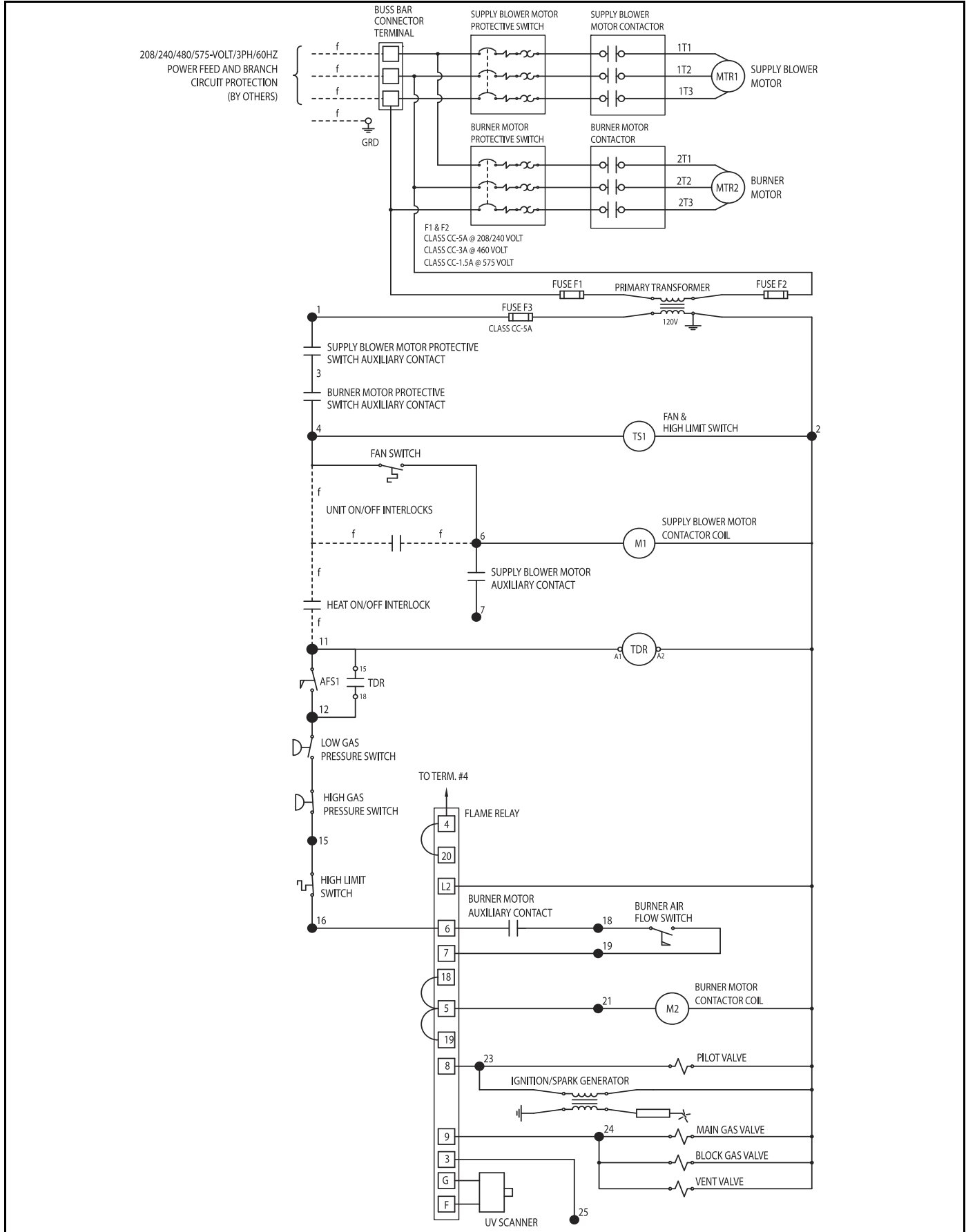

FIGURE 84: Wiring Diagram for Gas-Fired Air Handler with XL-Compliant Manifold and High/Low/Off Burner with Input Less Than 1,000 MBH (293.1 kW)

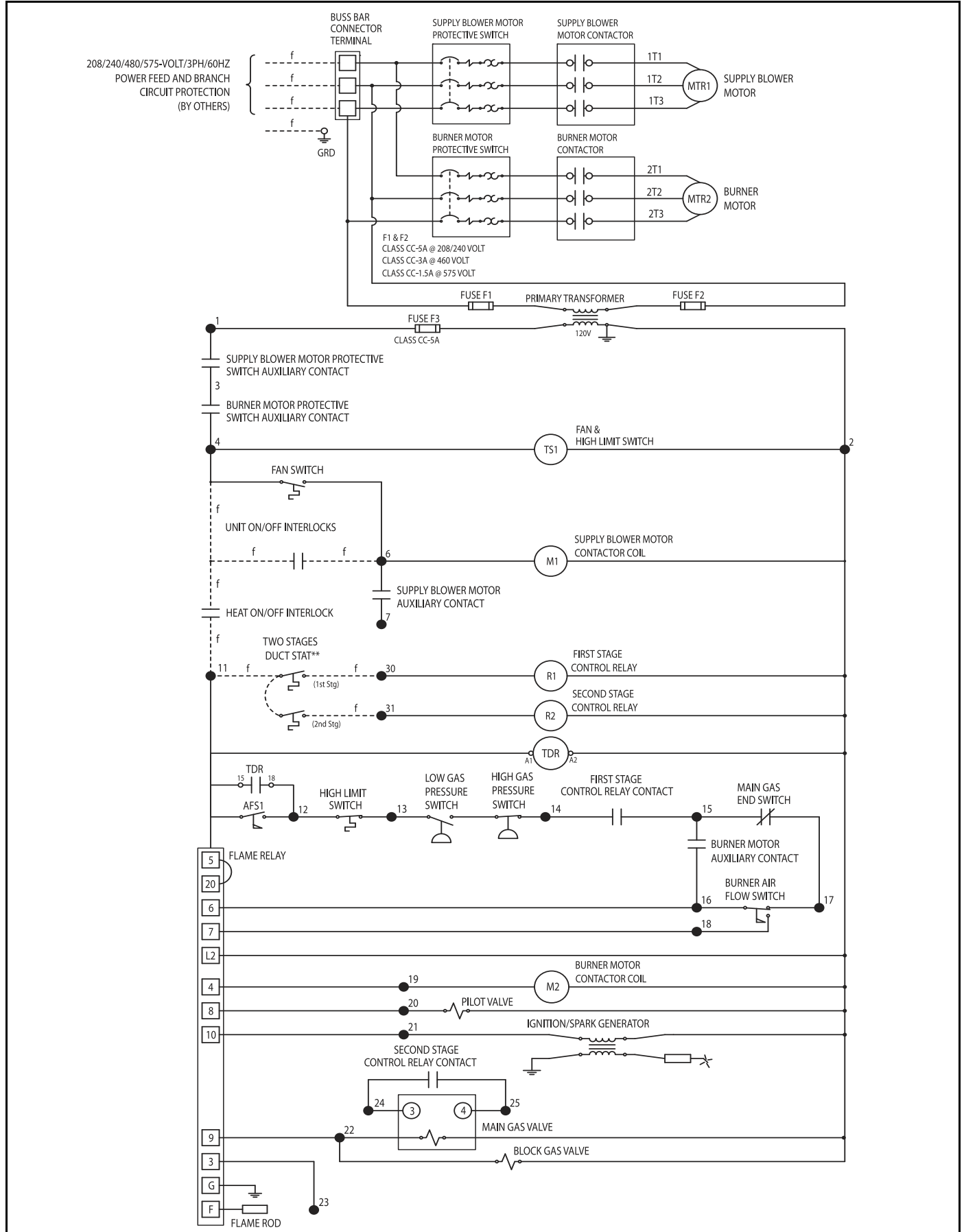

FIGURE 85: Wiring Diagram for Gas-Fired Air Handler with XL-Compliant Manifold and High/Low/Off Burner with Input 1,000 to 5,000 MBH (293.1 - 1465.4 kW)

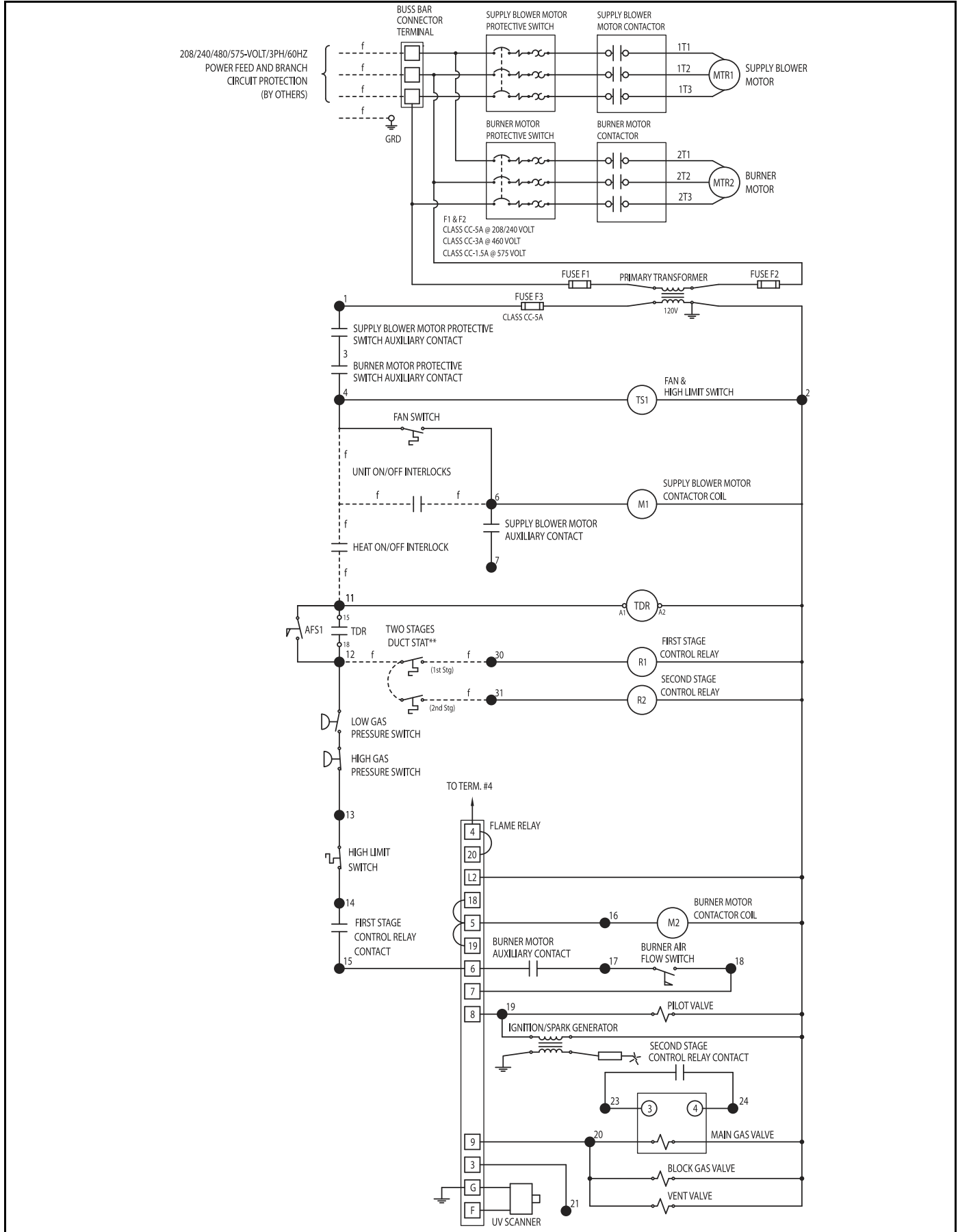

FIGURE 86: Wiring Diagram for Gas-Fired Air Handler with XL-Compliant Manifold and High/Low/Off Burner with Input More Than 5,000 MBH (1465.4 kW)

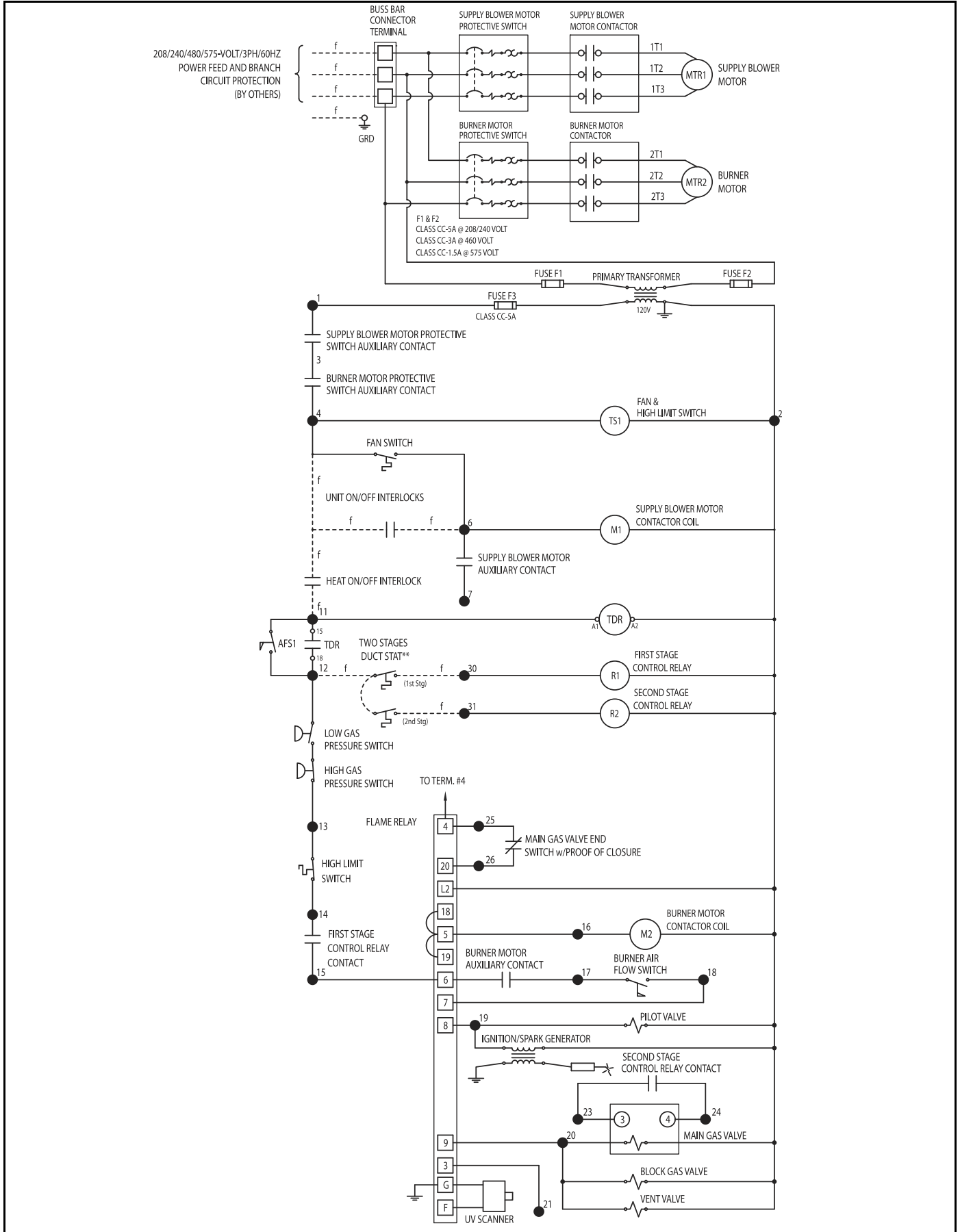

FIGURE 87: Wiring Diagram for Gas-Fired Air Handler with XL-Compliant Manifold and Fully-Modulating Burner with Input Less Than 1,000 MBH (293.1 kW)

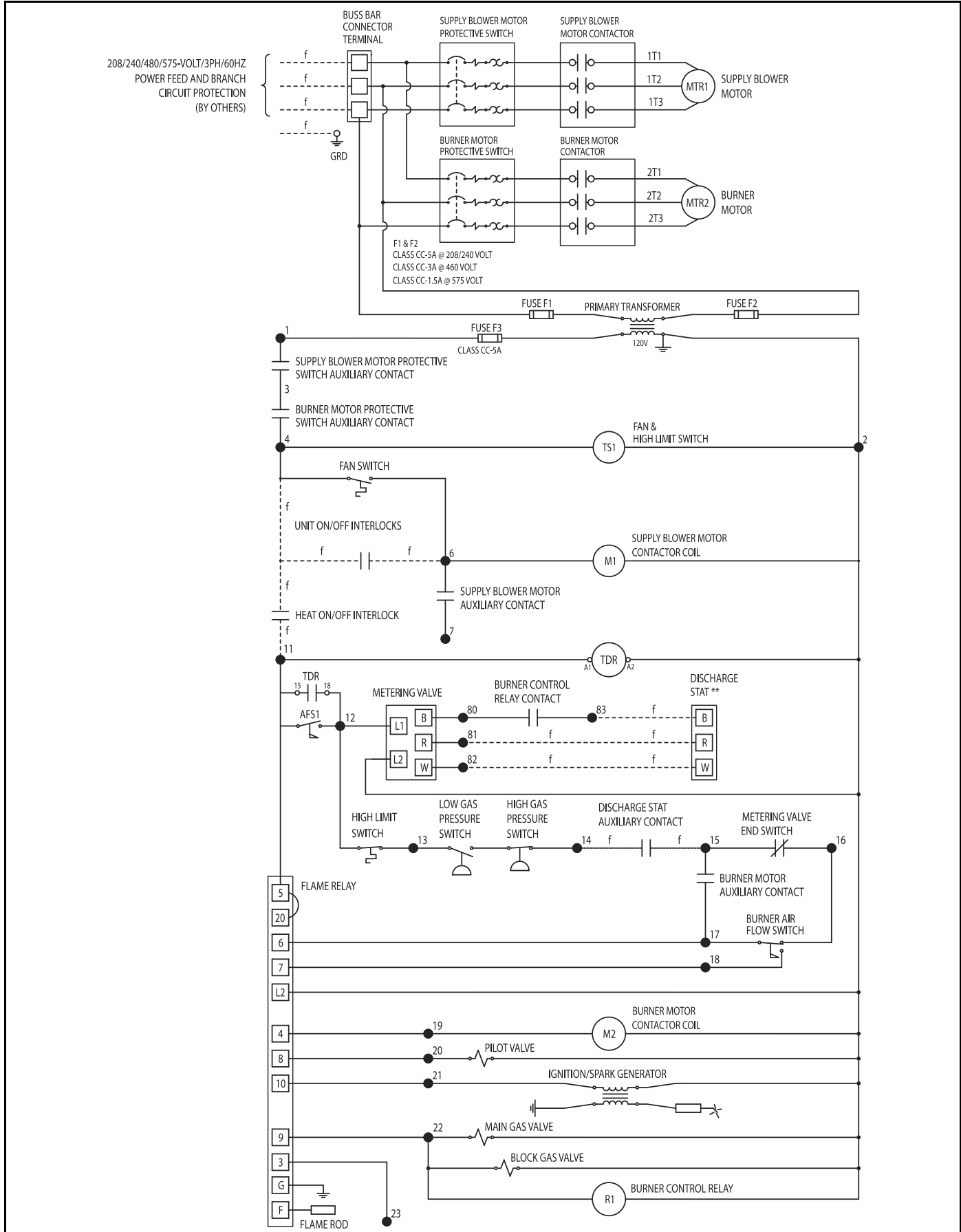

FIGURE 88: Wiring Diagram for Gas-Fired Air Handler with XL-Compliant Manifold and Fully-Modulating Burner with Input 1,000 to 5,000 MBH (293.1 - 1465.4 kW)

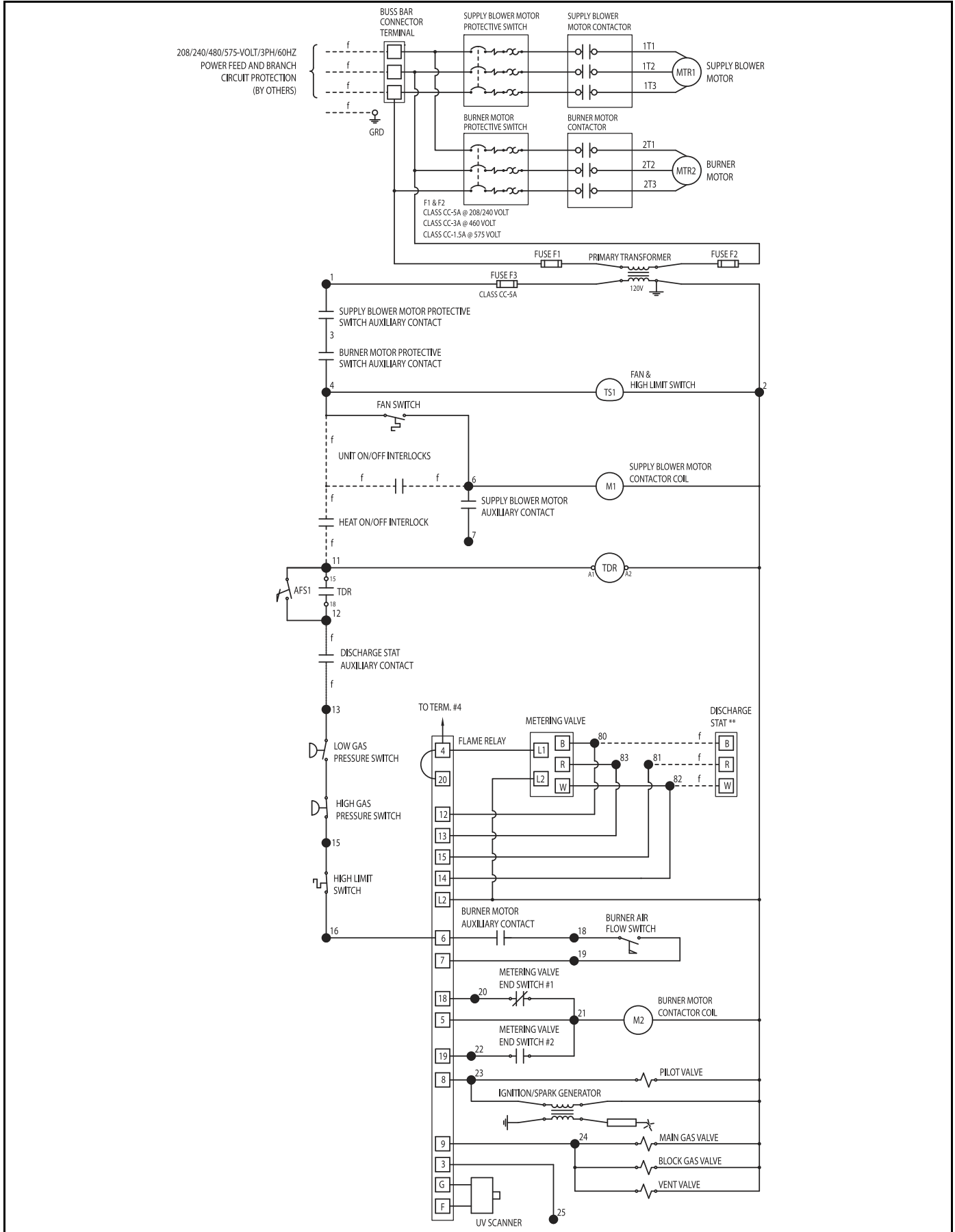

FIGURE 89: Wiring Diagram for Gas-Fired Air Handler with XL-Compliant Manifold and Fully-Modulating Burner with Input More Than 5,000 MBH (1465.4 kW)

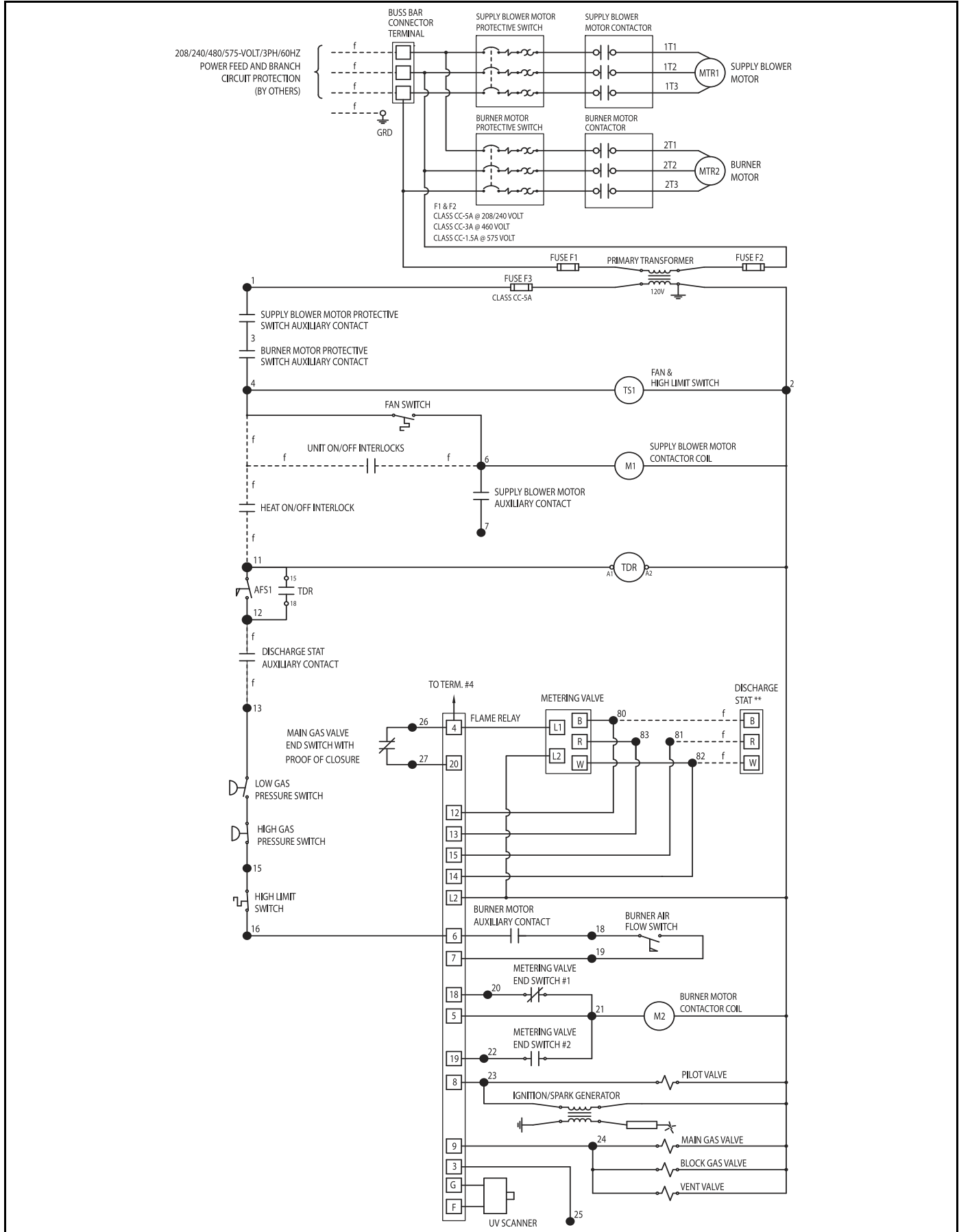

FIGURE 90: Wiring Diagram for Oil-Fired Air Handler with FM-Compliant Manifold and On/Off Burner with Input Less Than 2,500 MBH (732.7 kW)

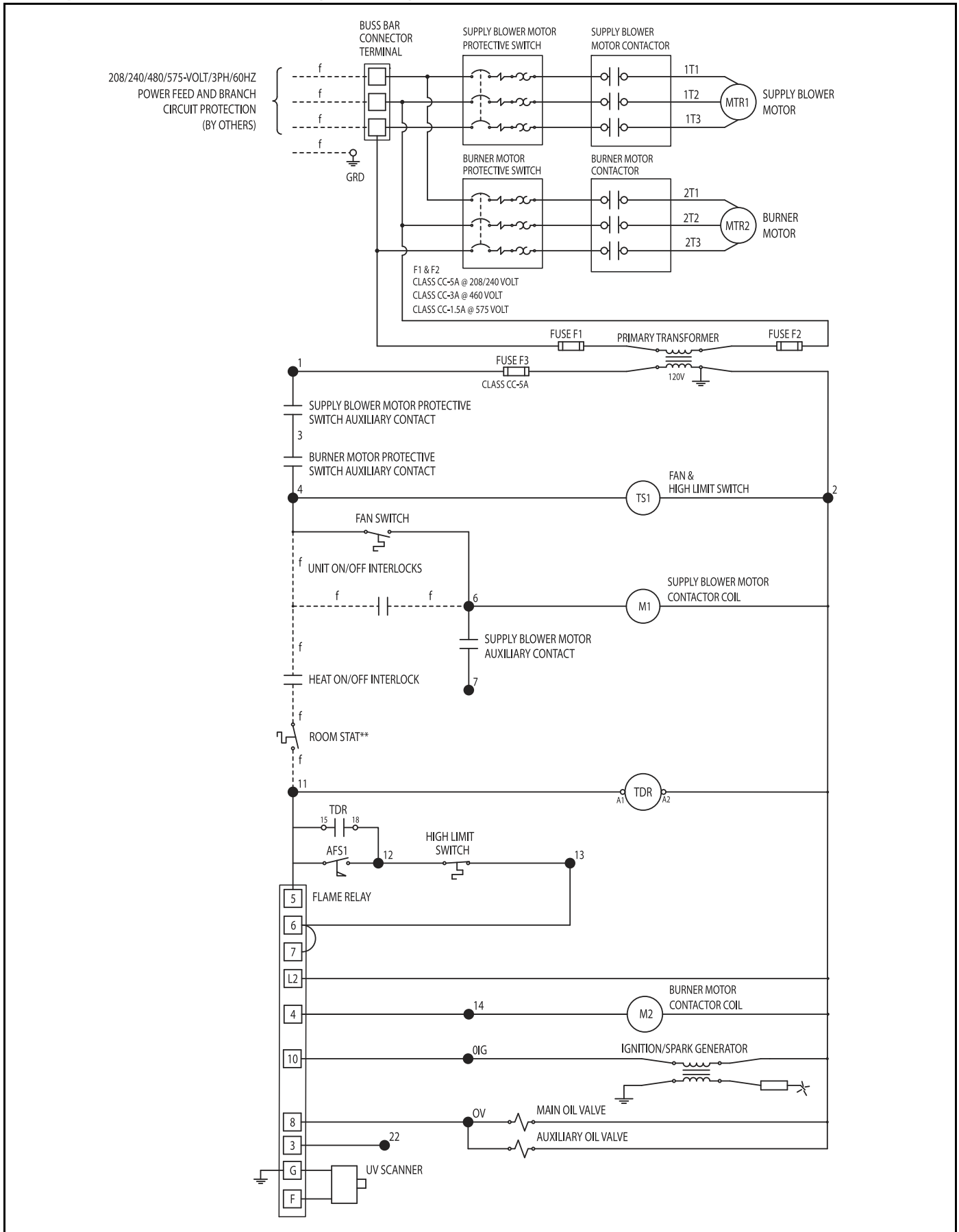

FIGURE 91: Wiring Diagram for Oil-Fired Air Handler with FM-Compliant Manifold and High/Low/Off Burner with Input Less Than 2,500 MBH (732.7 kW)

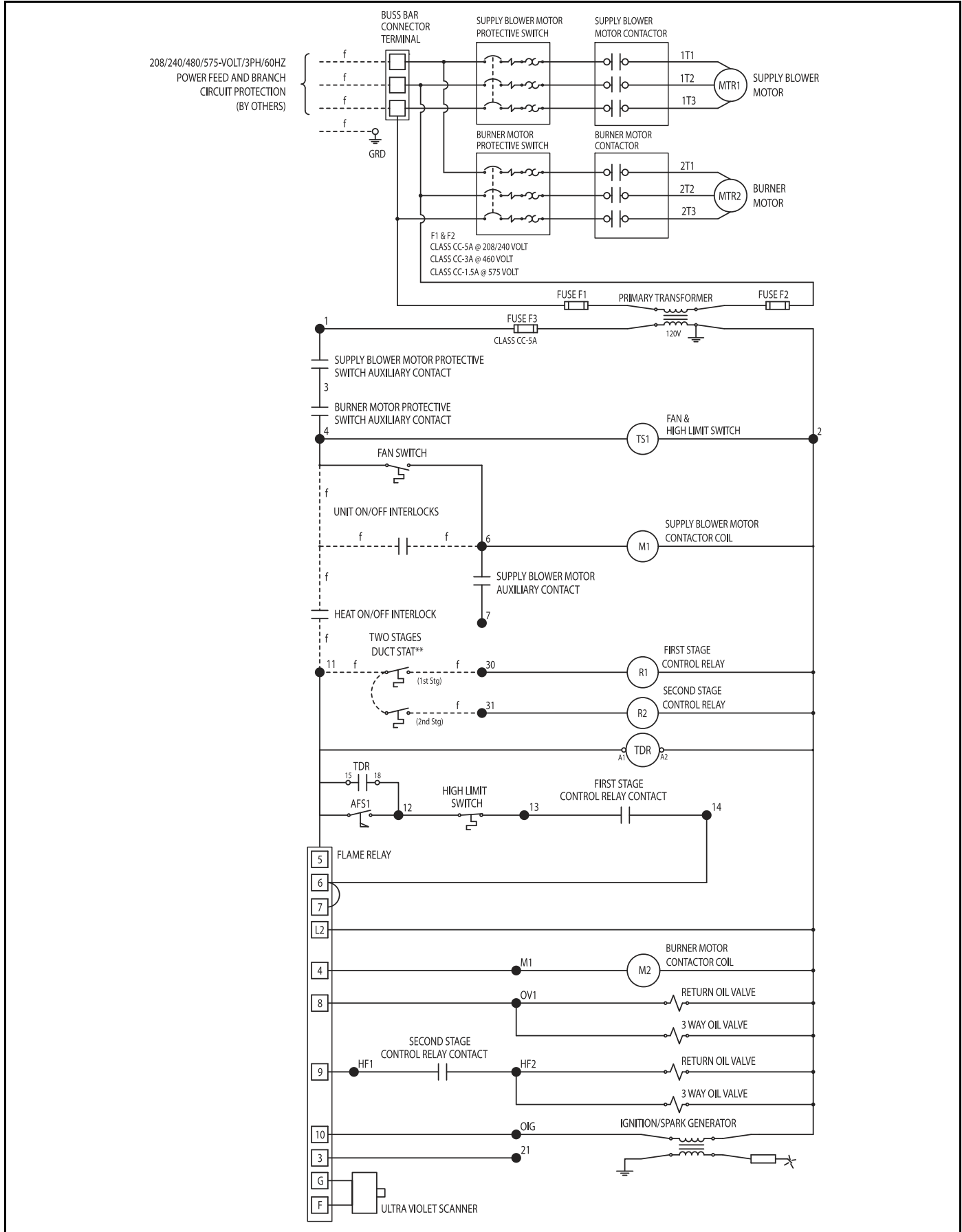

FIGURE 92: Wiring Diagram for Oil-Fired Air Handler with FM-Compliant Manifold and High/Low/Off Burner with Input More Than 2,500 MBH (732.7 kW)

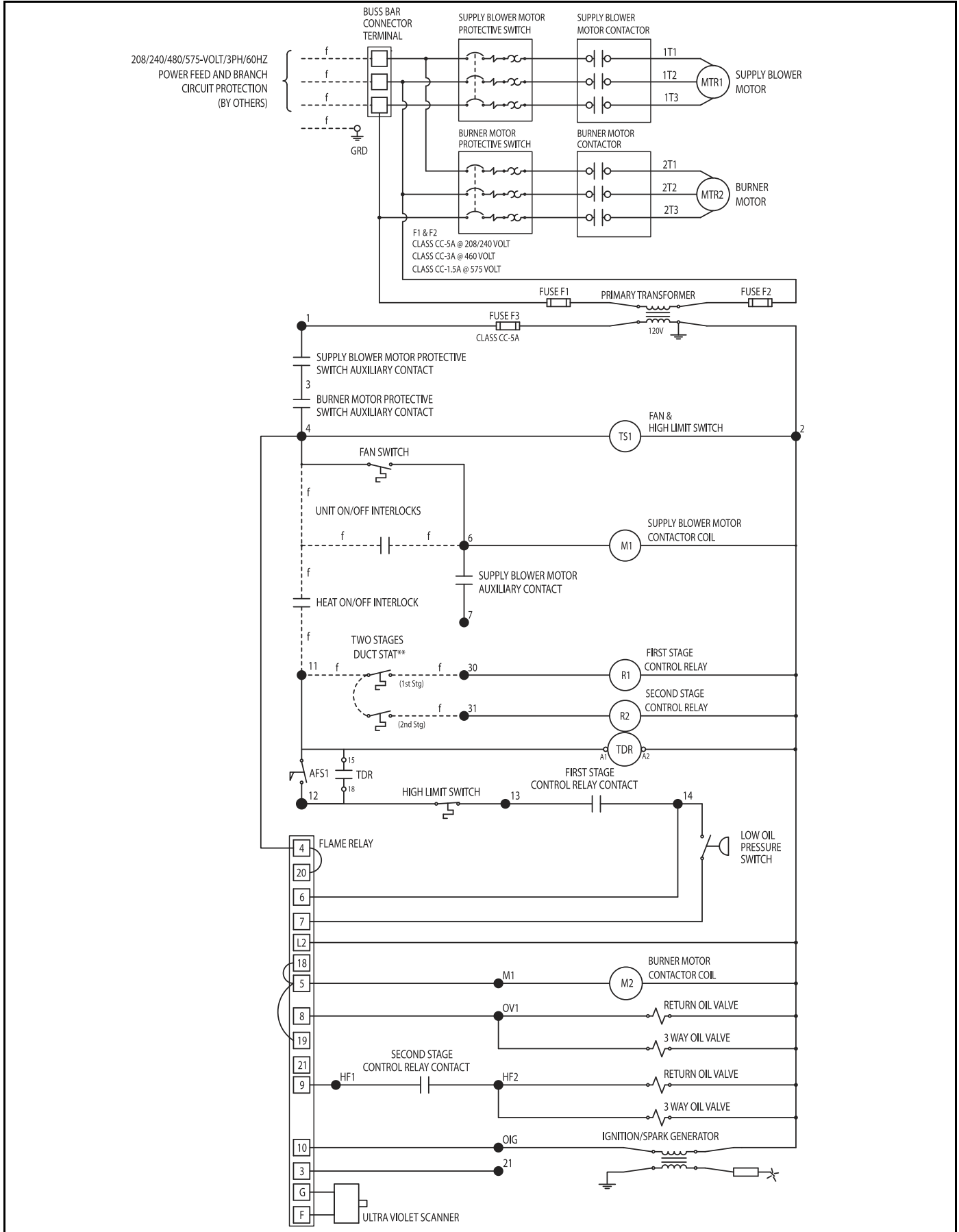

FIGURE 93: Wiring Diagram for Oil-Fired Air Handler with FM-Compliant Manifold and Fully-Modulating Burner with Input Less Than 2,500 MBH (732.7 kW)

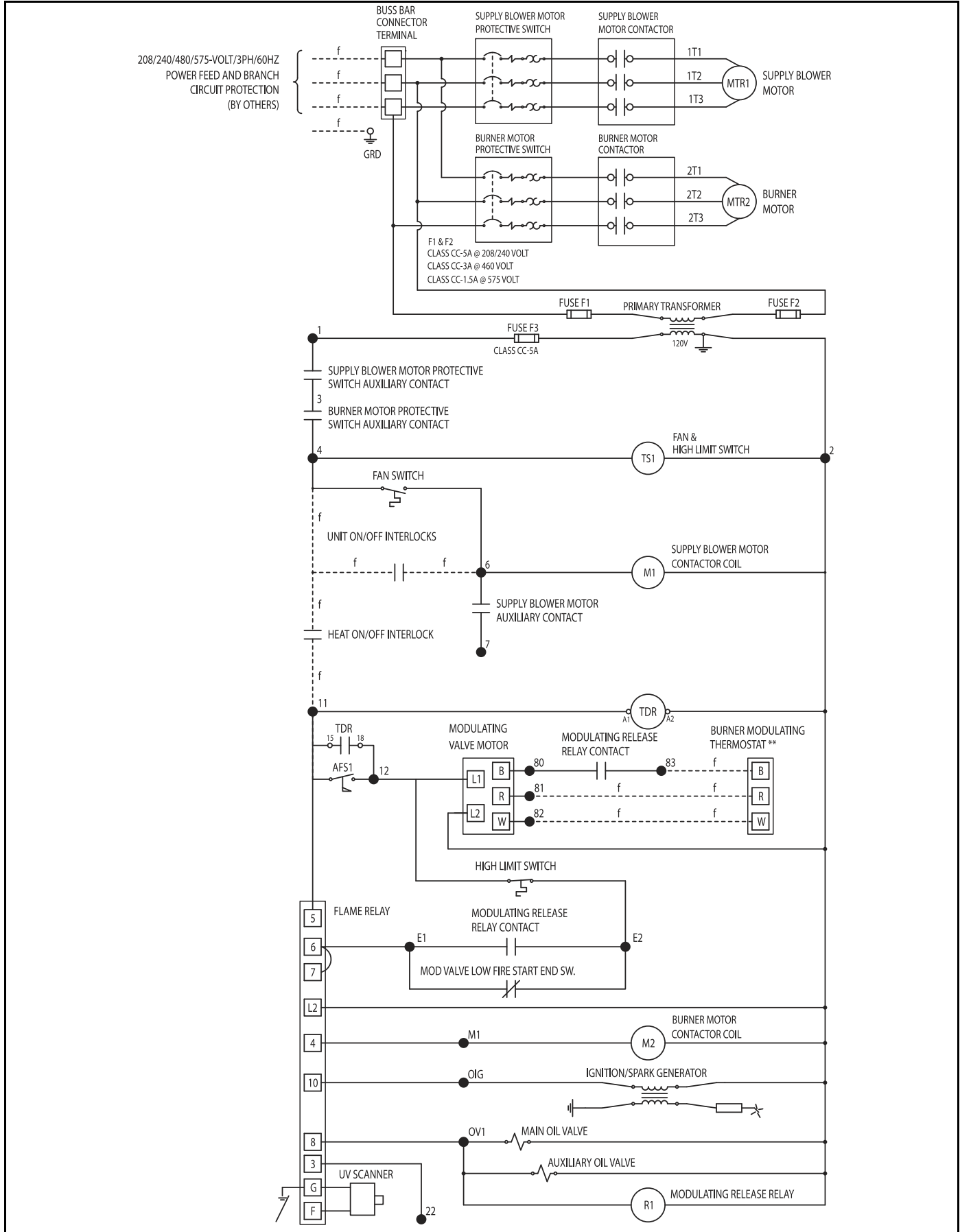

FIGURE 94: Wiring Diagram for Oil-Fired Air Handler with FM-Compliant Manifold and Fully-Modulating Burner with Input More Than 2,500 MBH (732.7 kW)

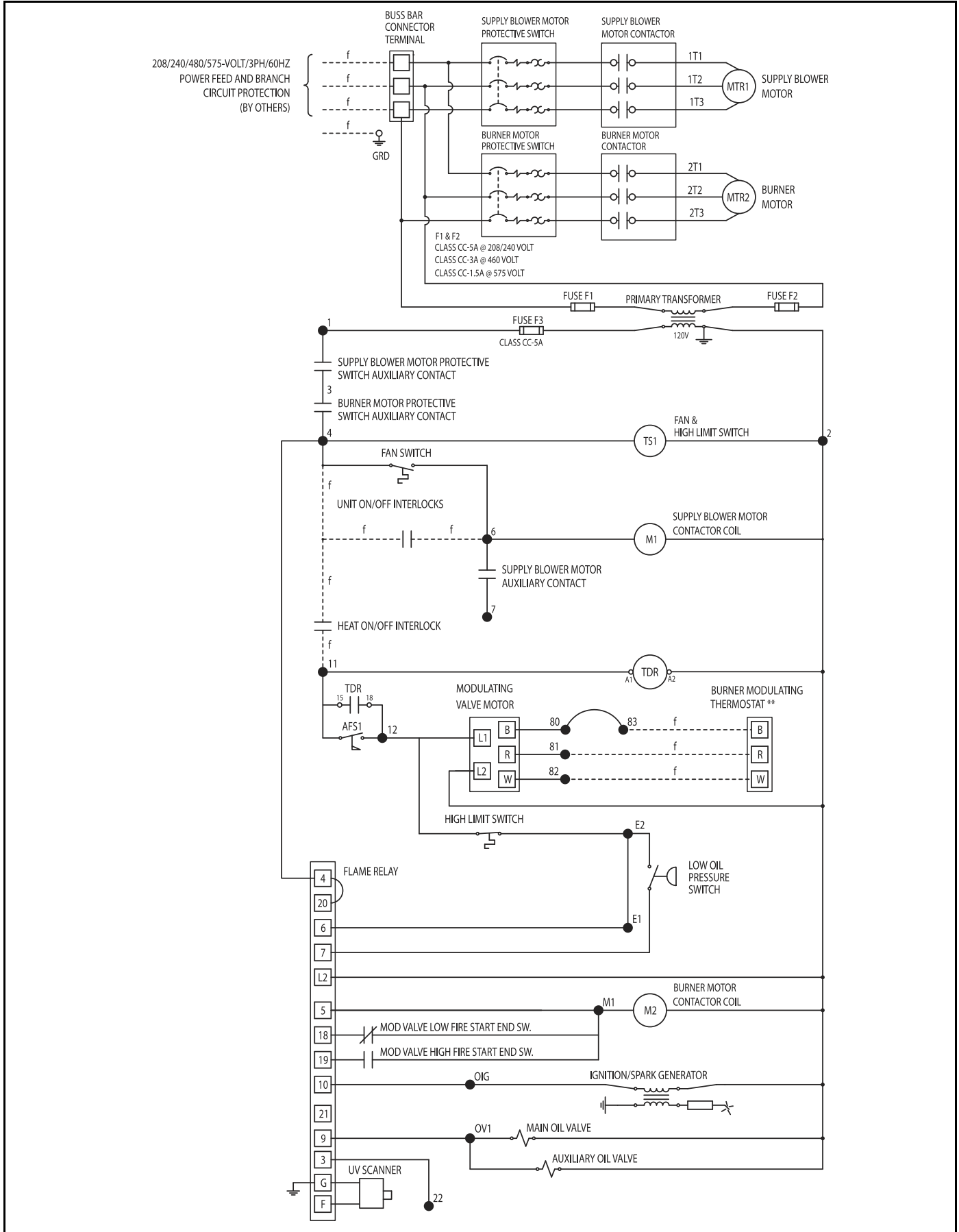

FIGURE 95: Wiring Diagram for Oil-Fired Air Handler with XL-Compliant Manifold and On/Off Burner with Input Less Than 1,000 MBH (293.1 kW)

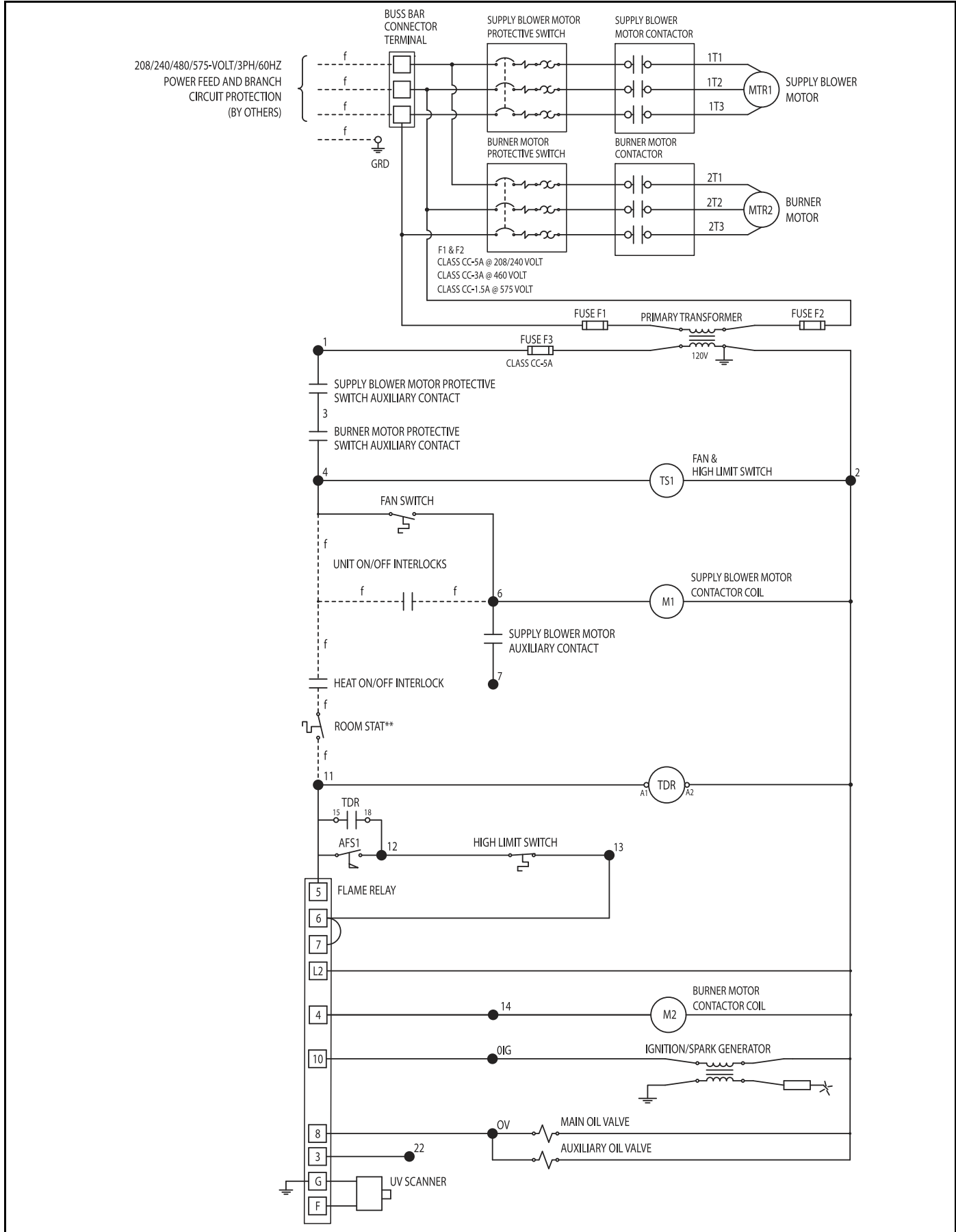

FIGURE 96: Wiring Diagram for Oil-Fired Air Handler with XL-Compliant Manifold and On/Off Burner with Input Less Than 2,500 MBH (732.7 kW)

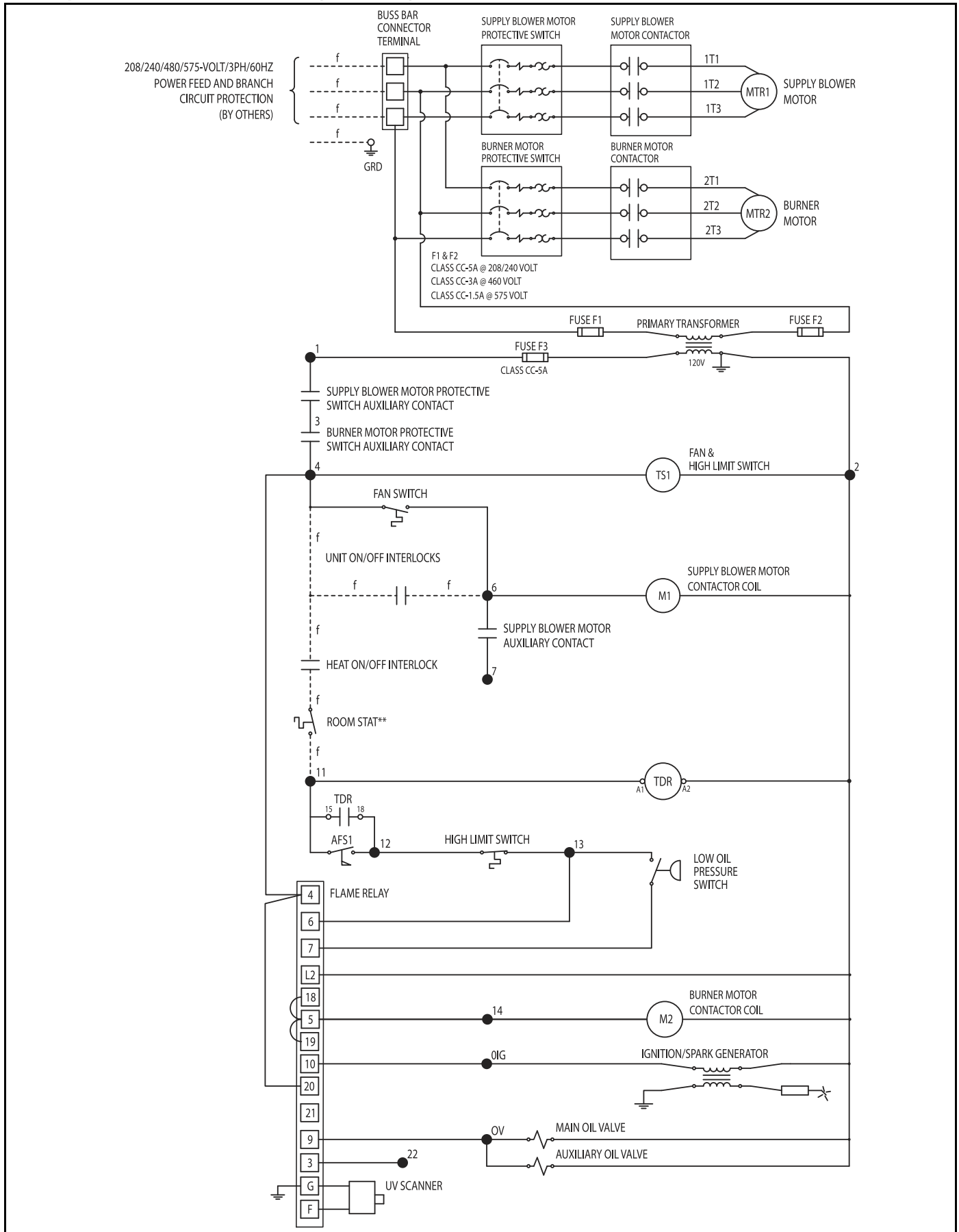

FIGURE 97: Wiring Diagram for Oil-Fired Air Handler with XL-Compliant Manifold and High/Low/Off Burner with Input Less Than 1,000 MBH (293.1 kW)

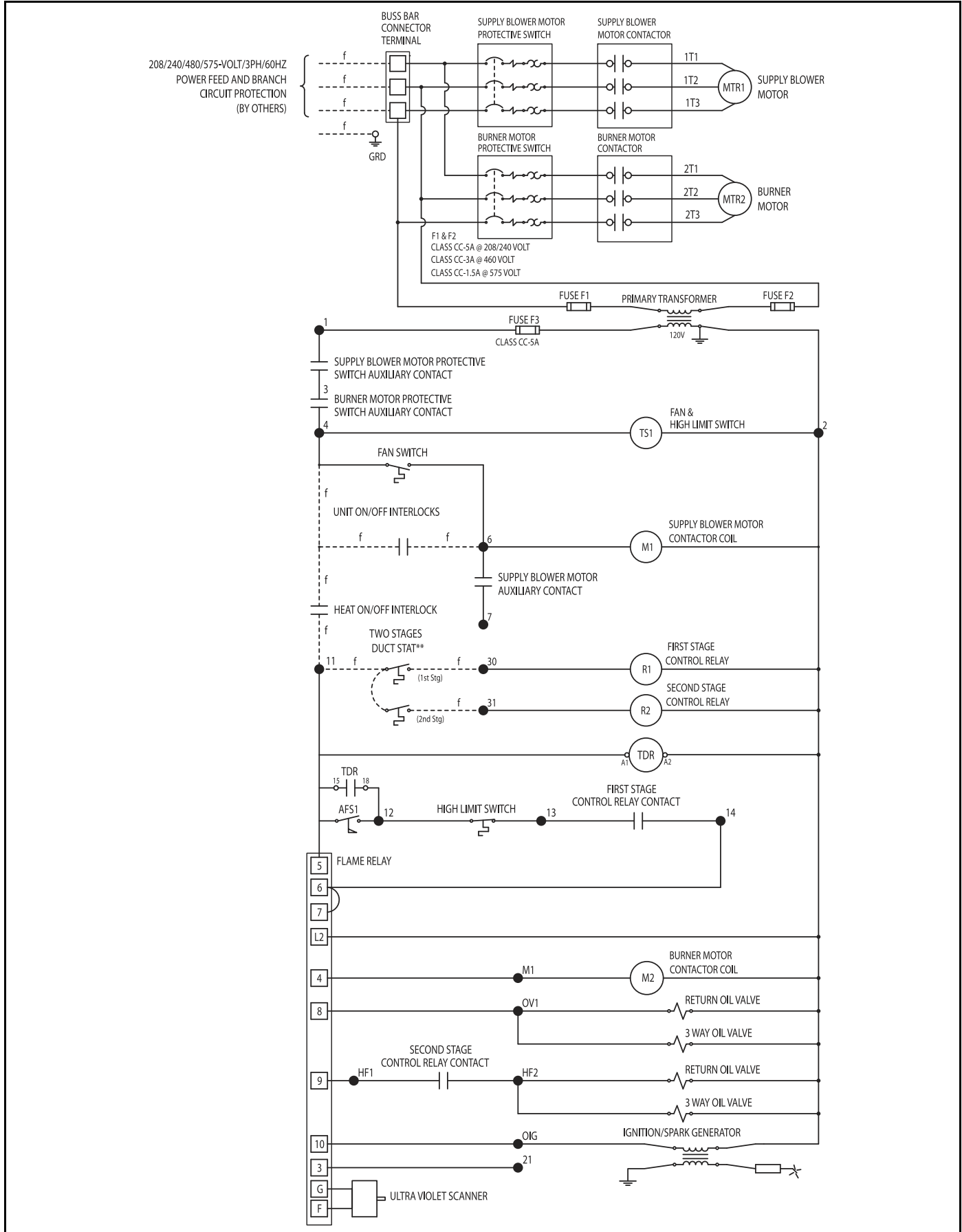

FIGURE 98: Wiring Diagram for Oil-Fired Air Handler with XL-Compliant Manifold and High/Low/Off Burner with Input More Than 1,000 MBH (293.1 kW)

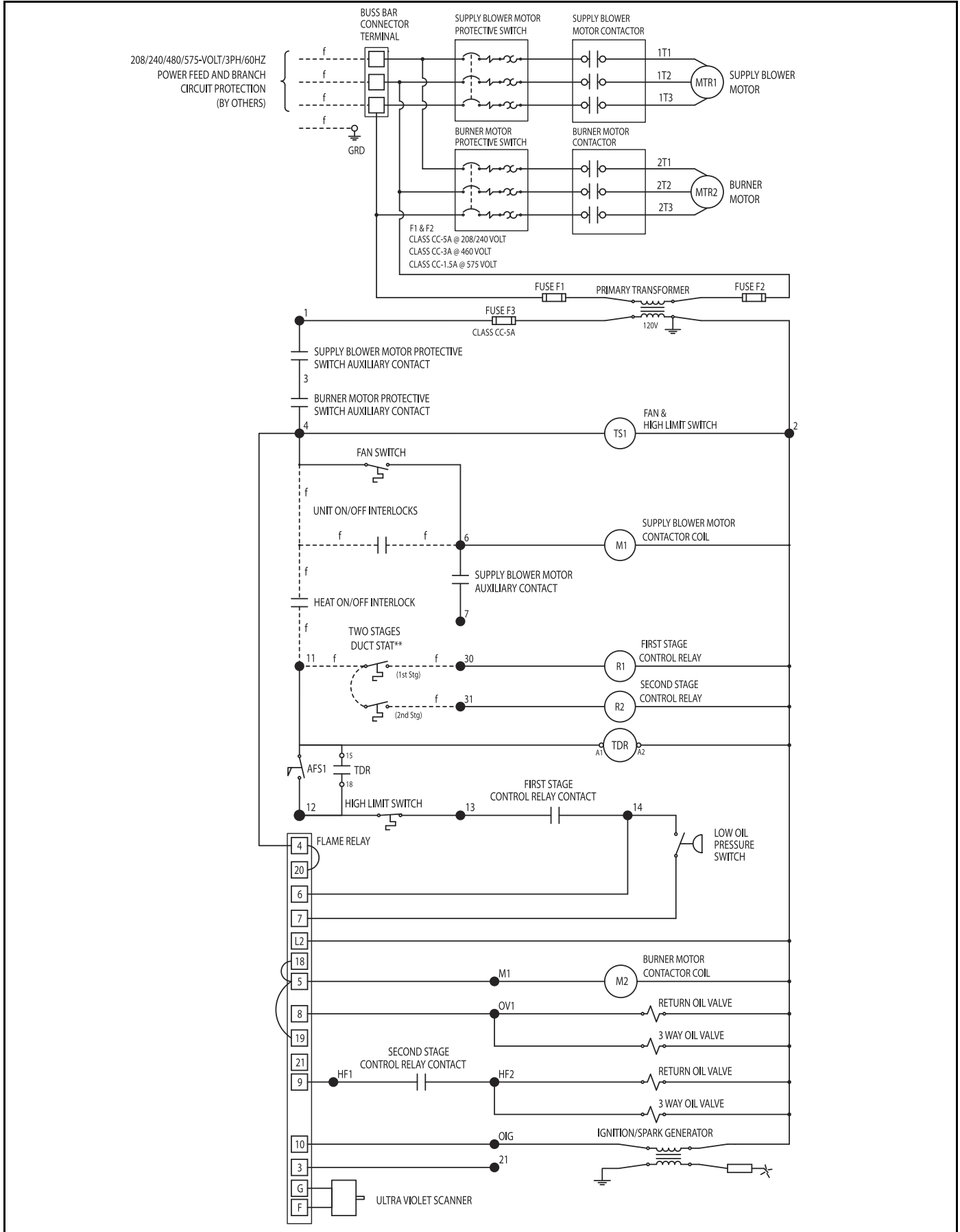

FIGURE 99: Wiring Diagram for Oil-Fired Air Handler with XL-Compliant Manifold and Fully-Modulating Burner with Input Less Than 1,000 MBH (293.1 kW)

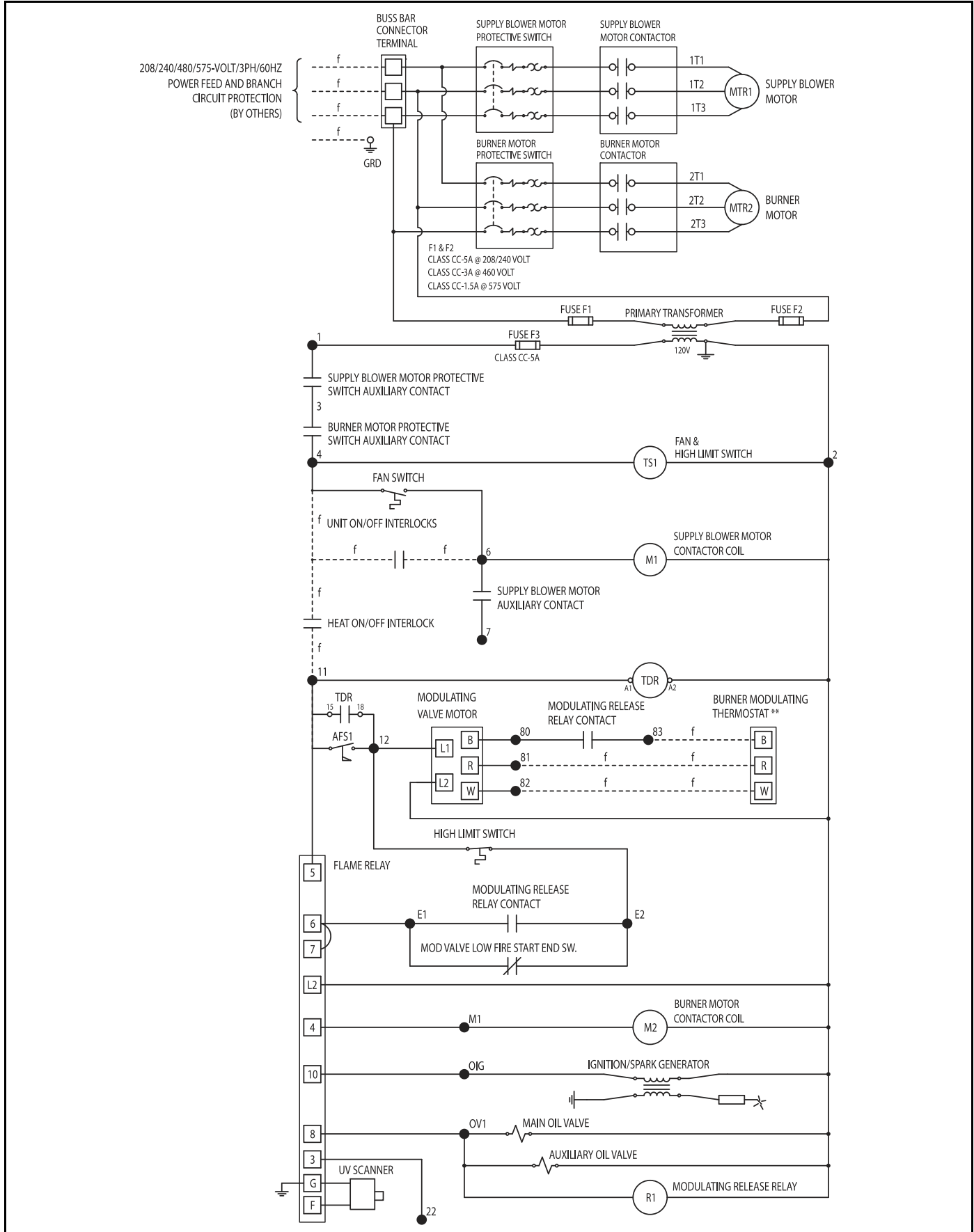
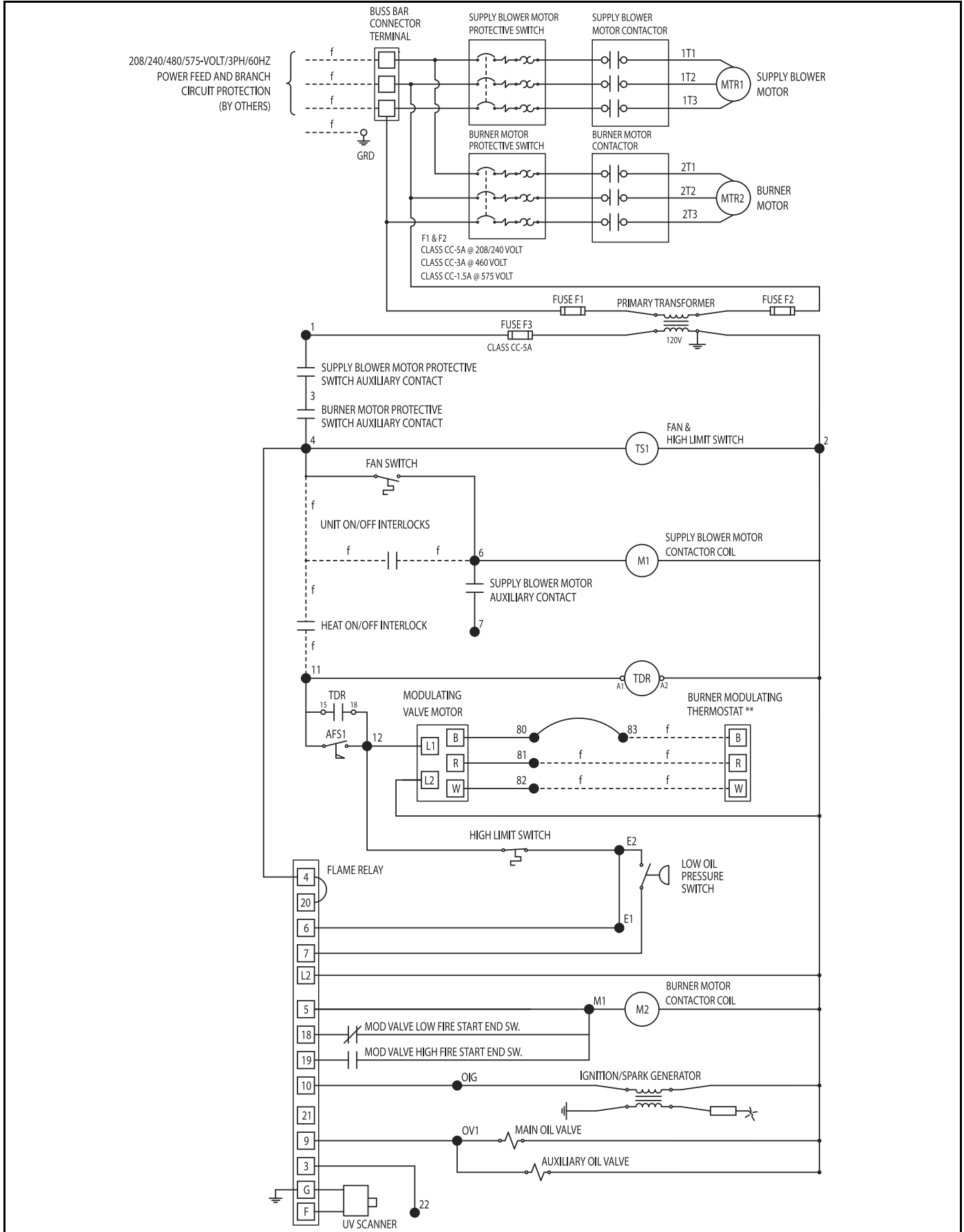

FIGURE 100: Wiring Diagram for Oil-Fired Air Handler with XL-Compliant Manifold and Fully-Modulating Burner with Input More Than 1,000 MBH (293.1 kW)



SECTION 24: SEQUENCE OF OPERATION

⚠ DANGER**Electrical Shock Hazard****Disconnect electric before service.****More than one disconnect switch may be required to disconnect electric from equipment.****Equipment must be properly grounded.****Failure to follow these instructions can result in death or electrical shock.****24.1 Air Handler Configuration**

Based on the air handler application, the air handler may be configured in any of the following styles to achieve the described functionality. These configurations are available on all air handlers. For a comparison of these configurations, see *Page 122, Table 23 and Page 123, Figure 101*.

Table 23: Configuration Chart

Heater Configuration	Air Flow	Air Volume	Control
Make Up Air (MUA)	100% Outside Air	Constant	-
Fixed Return (FR)	Adjustable between 100% Outside Air and 100% Return Air	Constant	Manual Potentiometer on Remote Panel
Air Management (AM)	Adjustable between 100% Outside Air and 100% Return Air	Constant	Building Pressure Control

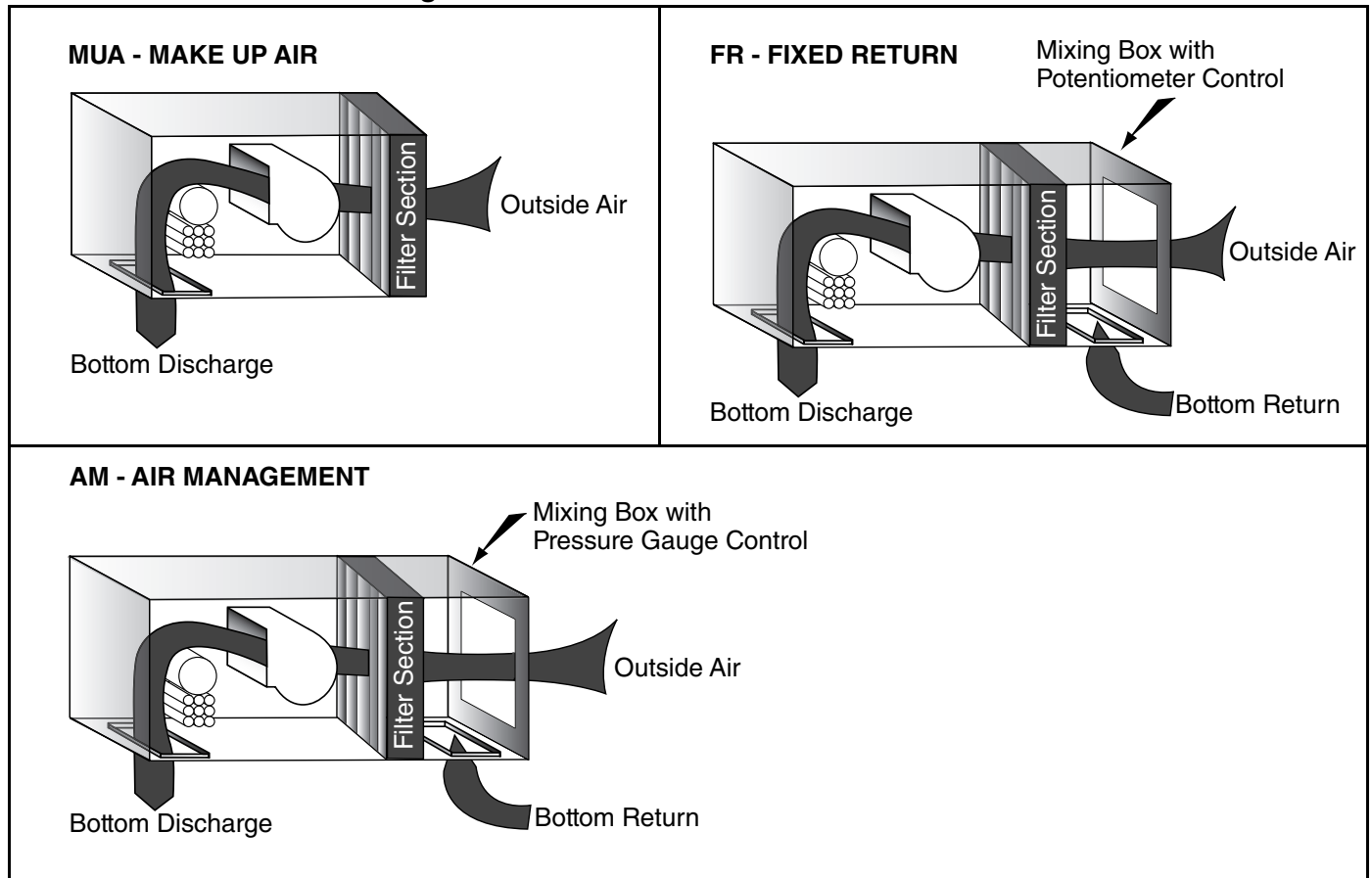
FIGURE 101: Air Handler Configurations

24.2 Remote Panel Options

The remote panel should be mounted in the conditioned space in a convenient location for controlling the air handler. Care must be taken when locating a remote panel that contains temperature sensing equipment, such that it is not located in an area that is directly affected by this air handler or another heat source as it may interfere with the operation of the air handler.

24.2.1 8.1 Remote Panel



The 8.1 Remote Panel includes Summer/Off/Winter switch and blower, burner, and flame failure indicators in a NEMA 1 style enclosure.

Blower Indicator:

Indicates the air handler is supplying power to the main fan motor via the motor controls.

Burner Indicator:

Indicates that the air handler has supplied power to open the main fuel shut off valve.

Flame Failure Indicator:

The burner control module has experienced a fault and will need to be reset. The burner control module must be reset at the air handler. Refer to the Maintenance and Trouble Shooting sections of this manual to determine the cause of the fault.

Summer/Off/Winter Switch:

Summer position:

The blower will operate without the burner for summer ventilation.

Winter position:

The blower and burner will operate as needed for the application to maintain airflow and temperature.

24.2.2 8.5 Remote Panels

8.5 Remote Panel for Air Handlers with On/Off or High/Low/Off Burners



8.5 Remote Panel for Air Handlers with Modulating Burners



The 8.5 Remote Panel includes Summer/Off/Winter switch and blower, burner, and flame failure indicators in a NEMA 1 enclosure and temperature controller.

Blower Indicator:

Indicates the air handler is supplying power to the main fan motor via the motor controls.

Burner Indicator:

Indicates that the air handler has supplied power which opens the main fuel shut off valves.

Flame Failure Indicator:

The burner control module has experienced a fault and will need to be reset. The burner control module must be reset at the air handler. Refer to the Maintenance and Trouble Shooting sections of this manual to determine the cause of the fault.

Summer/Off/Winter Switch:

Summer position:

The blower will operate without the burner for summer ventilation.

Winter position:

The blower and burner will operate as needed for the application to maintain airflow and temperature.

The On-Off / Staged / Modulating temperature controller (whether space / discharge / return air) would be set from here.

24.2.3 DDC - Ready Option

The DDC-ready option provides inputs to receive control signals from a customer determined control system and outputs to provide sequence status to the same. With this option, the customer's control system would supply the blower and call for heat on/off function. For temperature control, this option allows for the customer to supply the following input signals; On/Off, Two-Stage or Modulation (4-20 mA, 0 or 2-10 vdc). The customer may control the temperature either based on discharge, space or return air temperature. A discharge sensor is required whenever space or return air control is used to limit the discharge temperature for proper air handler performance. For optimum efficiency, Roberts-Gordon LLC suggests to limit discharge temperature to 120° F (48.9° C). On FR and AM style air handlers, the customer's control system would also provide the input signal for the mixed box modulating dampers.

24.3 Basic Sequence of Operation

The following is an overview of the sequence of operation. Depending on the application and options supplied with the air handler, this can vary greatly. Thoroughly review all documentation for the air handler, including the electrical print, to familiarize and understand the actual sequence of operation.

Summer (Blower Only)

With power supplied to the air handler and the Summer/Off/Winter switch on the remote panel in the SUMMER position, power is supplied to the blower motor starter coil, allowing the blower motor to start. The burner circuit is NOT energized.

Winter (Blower & Burner)

With power supplied to the air handler and the Summer/Off/Winter switch on the remote panel in the Winter position, power is supplied to the heating circuit.

The flame relay is powered up through the air handler's airflow switch warm-up bypass timer circuit, high temperature limit switch, and low gas pressure switch and high gas pressure switch (if provided).

When combustion airflow is proven by the burner

airflow switch, the burner ignition system is energized.

After the pilot flame or main flame is proven by the flame detector, the main and blocking valves are opened and the ignition system is de-energized.

The temperature control system is powered separately and controls the flow of the fuel/air mixture to maintain applicable space / discharge / return air set point temperature.

NOTE: Refer to the separate manufacturer's literature included with the documentation shipped with the air handler for proper set-up and operation of the temperature controls supplied.

After the heat exchanger reaches operating temperature, the fan controller closes and power is supplied to the air handler's blower motor starter coil, allowing the blower motor to start. The air handler's airflow switch closes and the warm-up bypass timer completes its time out cycle, removing the bypass circuit and allowing the burner to function only as long as airflow is present throughout the air handler.

Light-Off of On/Off Burners

This firing mode is only available for models having an input of 2,500 MBH (732.7 kW) or less.

The combustion air dampers are adjusted and locked in place for the most efficient firing rate. Smooth light-off on gas is achieved by the use of a slow opening valve, which, once open, allows gas flow to steadily increase from the initial light-off volume up to required firing rate.

Smooth light-off on oil is achieved by the use of a solenoid valve bypass system which allows a reduced amount of oil to be burned at light-off and then switching to the required firing rate once low fire has been established.

Light-Off of High/Low/Off Burners

For gas, movable combustion air dampers are mechanically linked with a slow opening valve to provide a smooth light-off position. The flow of gas is controlled by this valve which will move to its designated low fire volume and then to its high fire volume through readjusting the combustion air dampers through mechanical linkage. As requirements change, the burner will move between low fire and high fire, as needed.

For oil, the same dampers are operated by a hydraulic cylinder which, through mechanical linkage, provides a smooth light-off in the low fire position and then open to a point where the high fire rate will be

achieved if needed. Smooth oil light-off is further achieved by the use of a solenoid valve bypass system, which allows a reduced amount of oil to flow at light-off and then switches to the high fire rate (simultaneously energizing the hydraulic cylinder) as needed once low fire has been established.

Light-Off of Fully-Modulating Burners

The gas system utilizes an automatic valve to control the on/off flow of the fuel. A modulating motor controls the modulated positioning of a butterfly type proportioning valve. The modulating motor also controls the positioning of the combustion air dampers, through appropriate sequencing - providing low fuel/air input for a smooth low fire start and an infinite number of fuel air positions between low and high fire.

The oil system utilizes a solenoid valve to control the on/off flow of the fuel to the oil nozzle. A modulating motor controls the modulated positioning of a V ported metering oil valve located in the oil nozzle return line. The modulating motor also controls the positioning of the combustion air dampers, through appropriate sequencing - providing low fuel/air input for a smooth low fire start and an infinite number of fuel air positions between full low and high fire.

24.3.1 Burner Control Module

Two types of burner control modules are used as standard. They are the Honeywell RM7897 and the RM7800. The Honeywell model RM7897 is used on air handlers with a FM compliant manifold and less than 2,500 MBH (732.7 kW) input and XL compliant equipment less than 1,000 MBH (293.1 kW) input. The Honeywell model RM7800 is used on air handlers with a FM compliant manifold and with 2,500 MBH (732.7 kW) input and greater and on air handlers with a XL compliant manifold and with 1,000 MBH (293.1 kW) input and greater. The burner control module is a safety device and not serviceable. See Page 126, Figure 102 and Page 127, Figure 103 for the detailed sequence of operation.

FIGURE 102: Wiring Subbase and Sequence Chart for RM7897 Burner Control Module

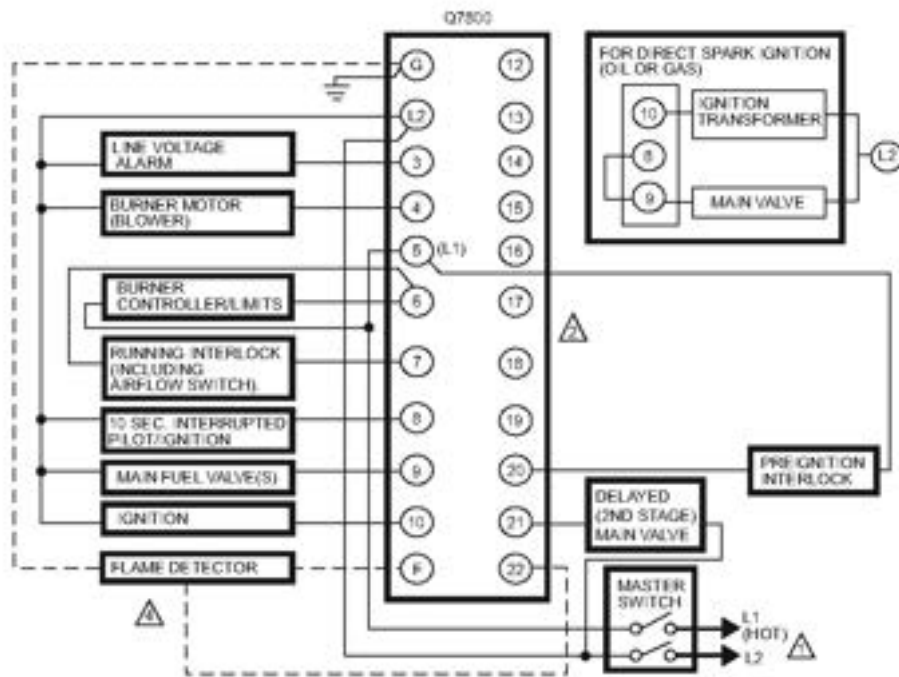

	INITIAL POWERUP ONLY	STANDBY	00 TIMED PREPURGE	00 10 SEC. PURGE (4 SEC. IF JRT CLIPPED)	10 MFEP	20 RUN	00 POSTPURGE	STANDBY
LED DISPLAY	● POWER ○ ○ ○ ○	● POWER ○ ○ ○ ○	● POWER ○ PLOT ○ FLAME ○ MAIN ○ ALARM	● POWER ● PLOT ● FLAME ○ MAIN ○ ALARM	● POWER ● PLOT ● FLAME ● MAIN ○ ALARM	● POWER ○ PLOT ○ FLAME ● MAIN ○ ALARM	● POWER ○ ○ ○ ○	● POWER ○ ○ ○ ○
BURNER			BURNER/BLOWER MOTOR (4)					
			(10) IGNITION					
			INTERRUPT/PILOT (8)					
				MAIN VALVE (9)				
				DELAYED MAIN VALVE (21)				
OPERATING CONTROLS AND INTERLOCKS			LIMITS AND BURNER CONTROLLER CLOSED (L1 TO 6)					
			RUNNING INTERLOCK (6 TO 7)					
			PRE-IGNITION INTERLOCK CLOSED (5 TO 20)					PI
FLAME SIGNAL		SAFE START CHECK			FLAME PROVING			SSC

⚠ 120 VAC, 50/60 HZ POWER SUPPLY. PROVIDE DISCONNECT MEANS AND OVERLOAD PROTECTION AS REQUIRED

⚠ DO NOT CONNECT ANY WIRES TO UNUSED TERMINALS.

⚠ PROGRAMMABLE POST PURGE TIMING USING S7800A1142 KDM.

⚠ SEE FLAME DETECTOR SPECIFICATIONS FOR CORRECT WIRING.

⚠ PURGE TIME DEPENDS ON WHICH S7800 IS INSTALLED.

FIGURE 103: Wiring Subbase and Sequence Chart for RM7800 Burner Control Module

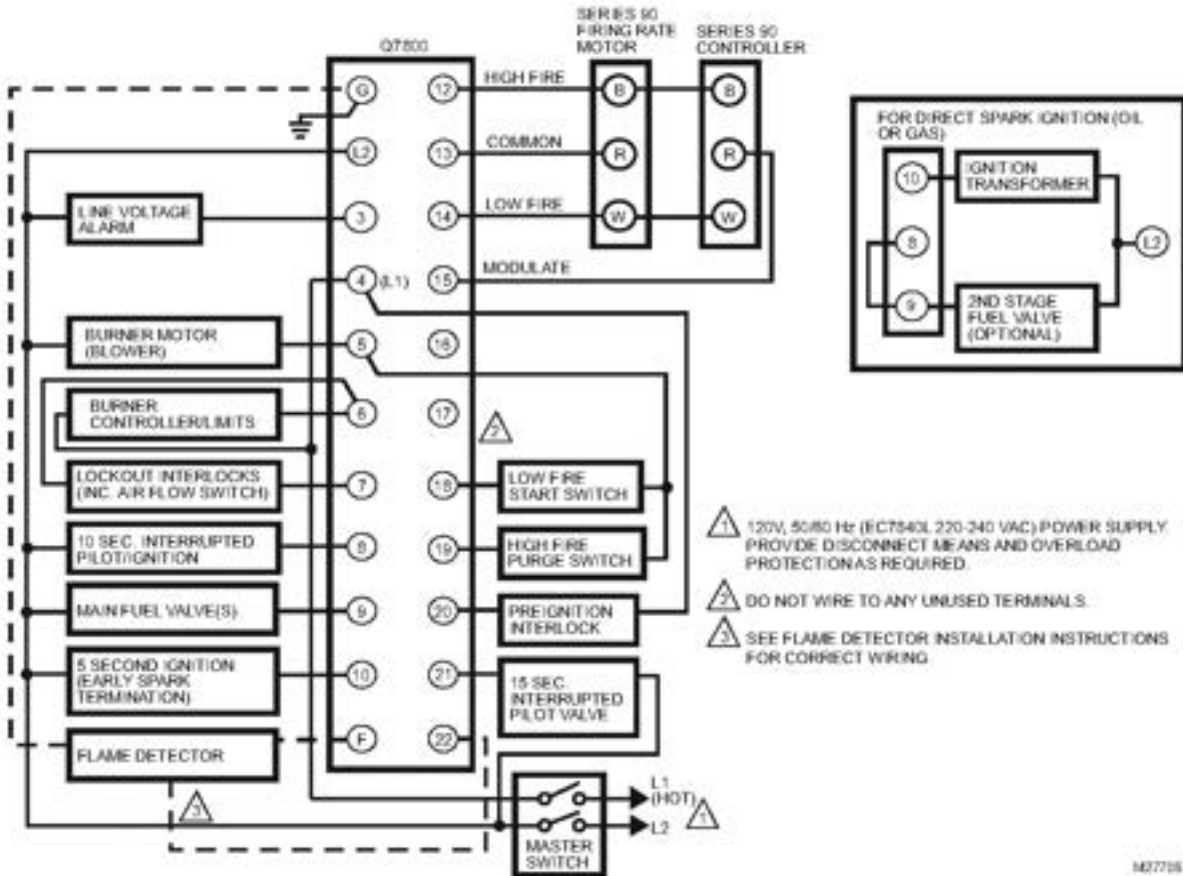

M07758

RM7800/RM7840L/EC7840L

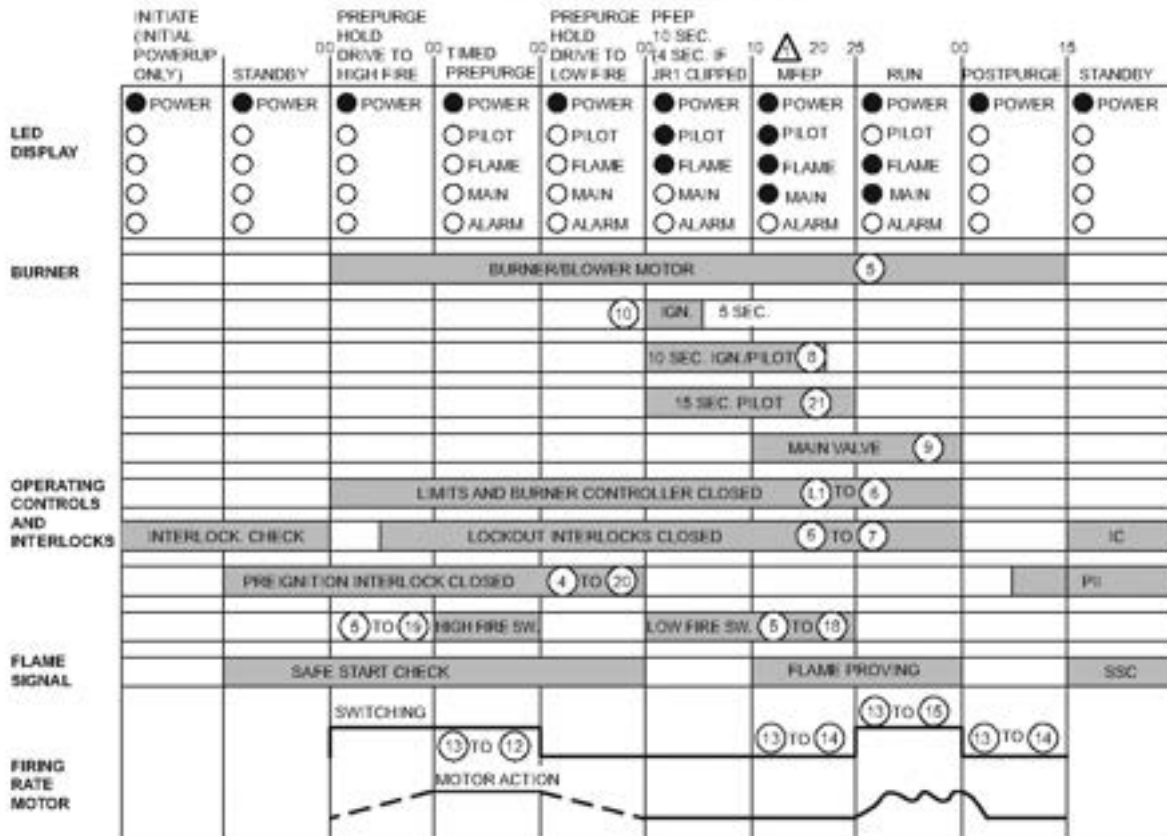

△ RM7840L1091 HAS A FOUR SECOND MFEP

M07757

24.4 Night Setback Options

24.4.1 Night Setback with Occupied/Unoccupied Switch

This option provides manual control of occupied and unoccupied cycles, operated by an occupied/unoccupied switch. It includes a line voltage room thermostat (shipped loose) and an occupied/unoccupied switch (mounted on remote panel). During the unoccupied cycle, the air handler remains off until the room thermostat calls for heat. At that time, the air handler goes to a standard daytime sequence until the thermostat is satisfied.

24.4.2 Night Setback with Electro-Mechanical Time Clock

This option provides automatic control of occupied and unoccupied cycles, operated by an electro-mechanical time clock. It includes a seven-day electro-mechanical time clock (shipped loose). The time clock can be set for different on and off times any of the days during the seven-day period. During the unoccupied cycle, the air handler remains off until the room thermostat calls for heat. At that time, the air handler goes to a standard daytime sequence until the thermostat is satisfied.

24.4.3 Night Setback with Electronic Time Clock

This option provides automatic control of occupied and unoccupied cycles, operated by an electronic time clock. It includes a seven-day electronic time clock (mounted on the remote panel). The time clock can be set for different on and off times any of the days during the seven-day period. During the unoccupied cycle, the air handler remains off until the room thermostat calls for heat. At that time, the air handler goes to a standard daytime sequence until the thermostat is satisfied.

24.5 Other Control Options

24.5.1 Exhaust Fan Interlock

This option provides an interlock between an exhaust fan and an air handler. It includes a break in the control circuitry to which wiring from an auxiliary set of contacts on the starter of an exhaust fan can be connected.

24.5.2 Burner On/Off Outdoor Thermostat

This option de-energizes the burner circuit when the outside air temperature meets or exceeds the thermostat's setpoint. It includes a thermostat and

outside air sensor. The range of thermostat is 25 - 100° F (-3.9 - 37.8° C).

24.5.3 Low Limit Control

This option shuts down the air handler when the discharge temperature falls below the controller's setpoint. It includes a solid-state controller with timer and a thermistor-type discharge air temperature probe. The temperature range of the controller is 30 - 75° F (-1.1 - 23.9° C) and the timer range of the controller is 1-10 minutes. The controller is typically set for 35° F (1.7° C) and a 5-minute time delay in order to allow a warm-up period for the air handler when first being energized.

24.5.4 Unit Mounted On/Off Switch

This option provides manual operation of the air handler. It includes a double-pole, double-throw (DPDT) toggle switch (mounted in the air handler's control panel).

24.5.5 Post-Purge Timer

This option allows the supply fan on the equipment to run for a timed period (adjustable 1 to 100 minutes) after burner shutdown. It includes timer (mounted on air handler).

24.5.6 Pre-Purge Timer

This option allows the supply fan on the equipment to run for a timed period (adjustable 0.1 to 15 minutes) before allowing the burner to fire and run. It includes timer (mounted on air handler).

24.5.7 Clogged Filter Switch With Indicator Light

This option monitors the differential pressure drop across the filters and, when it meets or exceeds the setpoint, illuminates a light mounted on the remote panel. It includes a pressure differential switch (mounted on the air handler) and an indicator light (mounted on the remote panel).

24.5.8 Mixing Box Section Economizer Control

This option provides "free" cooling when the outside air temperature is below the conditioned space setpoint through automatic control of a mixing box section's outside air and return air dampers. It includes a controller, outside air sensor, and mixed (outside and return) air sensor.

24.5.9 Audible Alarm for Flame Failure

This option sounds an alarm upon burner failure. It includes an alarm bell/horn (mounted on the air handler's control panel or remote panel).

24.5.10 Service Receptacle Powered by Others

This option provides a service receptacle. It includes ground-fault interrupter (GFI) receptacle (mounted on the air handler). Power to the receptacle is supplied by the installer.



24.5.11 Service Receptacle with a 7 A Power Source from Air Handler



This option provides a service receptacle. It includes ground-fault interrupter (GFI) receptacle (mounted on the air handler). Power to the receptacle is supplied by a 7A power source from the air handler itself.

24.5.12 UL-Listed Flame Control Panel

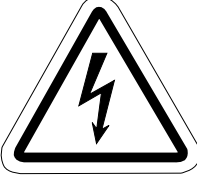
This option provides for the air handler's control panel to be built to Underwriters Laboratories (UL) standards. It includes an UL label on the control panel.

SECTION 25: START-UP PROCEDURES

⚠ DANGER	
	
<p style="text-align: center;">Electrical Shock Hazard</p> <p>Disconnect electric before service.</p> <p>More than one disconnect switch may be required to disconnect electric from equipment.</p> <p>Equipment must be properly grounded.</p>	<p style="text-align: center;">Severe Injury Hazard</p> <p>Do not enter equipment while in operation.</p> <p>Equipment may start automatically.</p> <p>Do not operate with door open.</p> <p>Installation, operation and service must be done by a trained technician only.</p>
<p>Failure to follow these instructions can result in death, electrical shock or injury.</p>	

⚠ WARNING		
		
<p style="text-align: center;">Explosion Hazard</p> <p>Leak test all components of equipment gas/oil piping before operation.</p> <p>Gas/oil can leak if piping is not installed properly.</p> <p>Do not high pressure test gas/oil piping with equipment connected.</p>	<p style="text-align: center;">Falling Hazard</p> <p>Use proper safety equipment and practices to avoid falling.</p> <p>Do not use any part of equipment as support.</p>	<p style="text-align: center;">Burn Hazard</p> <p>Allow equipment to cool before service.</p> <p>Internal components of equipment may still be hot after operation.</p>
<p>Failure to follow these instructions can result in death, injury or property damage.</p>		

Installation Code and Annual Inspections:

All installation and service of ROBERTS GORDON® equipment must be performed by a contractor qualified in the installation and service of equipment sold and supplied by Roberts-Gordon LLC and conform to all requirements set forth in the ROBERTS GORDON® manuals and all applicable governmental authorities pertaining to the installation, service operation and labeling of the equipment.

To help facilitate optimum performance and safety, Roberts-Gordon LLC recommends that a qualified contractor conduct, at a minimum, annual inspections of your ROBERTS GORDON® equipment and perform service where necessary, using only replacement parts sold and supplied by Roberts-Gordon LLC.

Check installation site to ensure all codes and engineering specifications are correct. This section of the manual is intended to be used as an instructional guide to the commissioning of the indirect fired air handler. Fill out the attached start up sheet (located at the back of the manual) as each step of the procedure is performed. This procedure should be completed by the commissioning contractor and returned to Roberts-Gordon LLC.

25.1 Mechanical**25.1.1 Sheave Alignment**

Sheaves are factory aligned. On all air handlers, check sheave alignment as follows.

1. Attach a string to the vertical surface next to the blower shaft bearing. (See Page 131, Figure 104)
2. Wrap the string around the blower sheave and across both sheave surfaces as shown.
3. Adjust until all four contact points (triangle) touch the sheave surfaces. "IN" or "OUT" adjustment of the motor sheave and/or motor adjustment may be required.
4. Pull the string away from the motor sheave and then move it slowly back towards the sheave, making sure the string remains straight while touching all contact points.
5. Remove string before turning air handler on.

NOTE: Allowances must be made for motor sheaves which are wider than the blower sheaves.

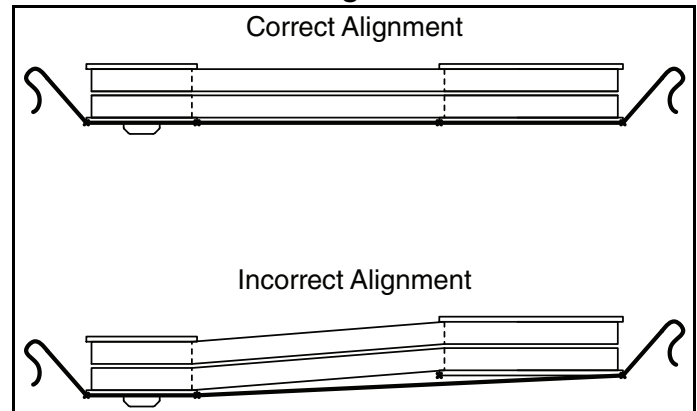
FIGURE 104: Sheave Alignment**25.1.2 Belt Tension**

- Belt tension should be checked with a belt-tension gauge when one is available. Follow the belt tension gauge instructions.
- When a tension gauge is not available, measure the belt span of the belts.
- Allow for 1/64" (.04 cm) of deflection for each inch of center distance length for the charted pounds of force. Check the table below for proper deflection force.
 - EXAMPLE: A 40" (101.6 cm) shaft center distance would dictate 40"/64" or 5/8" (1.59 cm) of deflection. With a standard B-type V-belt and a motor sheave measuring between 5.8" (1.59 cm) and 8.6" (21.84 cm), the belt will have proper tension if a 5/8" deflection can be achieved with a minimum of 6-3/8 inch lbs. and a maximum of 8-3/4 inch lbs. of pressure as measured with a belt tensioning gauge.

FIGURE 105: Belt Tension

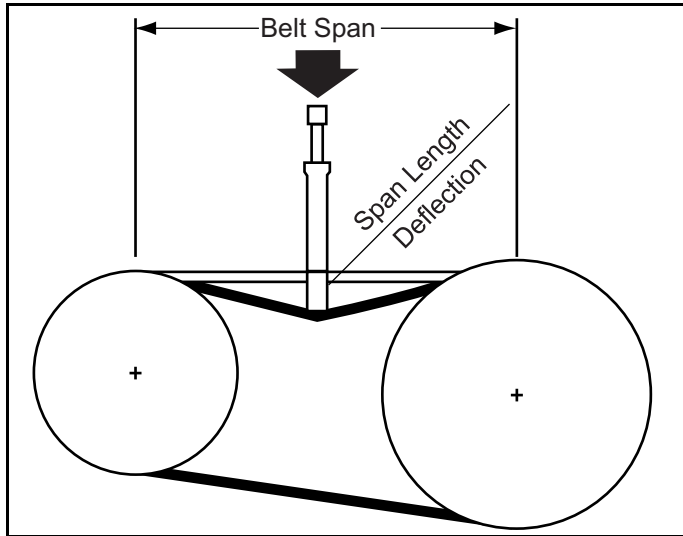

Table 24: Deflection Force of V-Belts

Belt Cross-Section	Motor Sheave Dimension Range (Inches) - (cm)	TYPE B		TYPE B-X (High H.P.)	
		Min.	Max.	Min.	Max.
B	3.4 - 4.2	4	5 1/2	5 3/4	8
	4.4 - 5.6	5 1/8	7 1/8	6 1/2	9 1/8
	5.8 - 8.6	6 3/8	8 3/4	7 3/8	10 1/8

NOTE: If drive belts squeal during start-up, increase belt tension to the highest allowed value. Re-check tension during each inspection.

25.2 Electrical

1. Check motor starter for proper overload settings. The overload setting must equal the full load amps (FLA) of motor.
2. Measure the supply voltage with the air handler off and then on. For a system that is powered with three phase power, measure the voltage of each phase.
3. Verify correct blower rotation.
4. While the blower is running and the burner is off, measure the total system current draw with an ammeter. Measure the system current draw again after the burner adjustments are made and with the burner and blower both on.
5. If applicable, compare all variable frequency drive programming parameters with specifications provided on electrical drawing.

25.3 Airflow

Factory calibrated, the air flow switches are safety devices for burner air flow. If an air flow switch does not close, the problem may not be the air flow switch. It could be an indication of an air flow problem (incorrect blower rotation, duct restrictions, etc.)

25.4 General Start-up Procedures (All Fuels)

A thoroughly qualified burner technician should be employed to provide the initial burner start up. Before beginning start up, the technician should thoroughly study and become familiar with the exact sequence of operation and all other details of the specific flame safeguard control system being used. Because of the various flame safeguard controls being utilized, a separate manufacturer's bulletin is supplied with the air handler.

Complete and/or review all precautions and inspection procedures in previous sections and burner manufacturers' literature.

Close main and manual burner shut-off valves. Open oil suction line manual valves and others as appropriate.

Tighten all screws on terminal blocks in control cabinet in case some may have loosened during transit.

Check vent stack to ensure it is open and unobstructed.

Check rotation of main supply motor and burner blower by momentarily making contact of the motor contactors/starters. Proper rotation is imprinted on the air handler for the supply fan and on the fan housing for the burner.

Check operating controls, limit controls, flame safeguard control reset, high and low gas and/or oil pressure switches (if used) and low fire interlocks (if used) and all other applicable interlocks. All contacts should be closed (an exception would be the low gas and/or oil pressure switch).

25.5 Blower Start-Up

Place main disconnect switch in the on position and the fan selector switch in the manual position and the Summer/Off/Winter switch in the summer position.

With the main supply fan motor running take and record its amp draw, return the selector to the off position.

25.6 Burner Start-Up

The standard burners are manufactured by Power Flame Incorporated®. The following start up information pertains to these burners. If a different manufacturer's burner is utilized, refer to the separate manufacturer's literature included with the documentation shipped with the air handler.

To help prevent unburned fuel in the heat exchanger,

do not repeatedly cycle the burner. Specific instructions relative to component sequencing are provided in the flame safeguard manufacturer's bulletin which is included with the documentation shipped with the burner.

Proper test equipment must be used in order to achieve maximum system operational reliability and fuel efficiencies.

All fuel/air adjustments should be made to achieve required input rate, satisfactory combustion test values, flame stability and appearance.

25.7 Gas Pressure Adjustments

All high fire adjustments, for whatever burner type - on/off, high/low/off and full modulation are accomplished by adjusting the main gas regulator located in the gas manifold. Refer to the equipment's serial tag for proper burner manifold pressure at high fire. See Page 79, Figure 58 through Page 82, Figure 61.

To adjust low fire on a high/low/off burner, the control actuator contains the adjustment means. See Page 133, Figure 106.

FIGURE 106: Low Fire Adjustment for High/Low/Off Burner

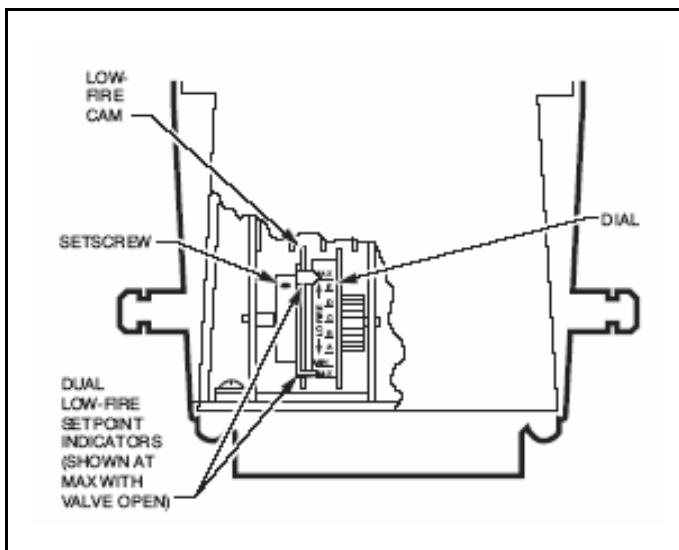

A dial on the low-fire cam indicates the low-fire setting. Because the cam rotates as the valve opens, scales are marked on the dial so the low-fire setting can be observed with the valve in any position. One scale is visible when the actuator is closed, and the other is visible when it is open. These scales are not independent; the same setting applies to both. The actuator is shipped from the factory with the low-fire

setting at a valve gas flow of approximately 40 percent, which is adequate for safe light-off until the final setting can be determined.

25.7.1 Recommended Procedure

To adjust the low-fire setting without energizing the actuator, proceed as follows:

1. Remove the wiring compartment cover.
2. Manually rotate the cam and dial assembly downward so that the setscrew is accessible from the front of the actuator.
3. Loosen the setscrew on the low-fire cam using the special wrench (supplied-taped to the inside of the actuator cover).
4. Set the cam to the predetermined low-fire setting for the burner being used.
5. Tighten the setscrew in the cam.
6. Replace the wiring compartment cover.

25.7.2 Alternate Procedure

To adjust the low-fire setting after the burner is in operation, use the following instructions:

1. Remove the wiring compartment cover.
2. Check to be sure the low-fire adjustment is set at 40% to assure a safe light-off. (Low-fire adjustment is preset at the factory.)
3. Disconnect the firing rate controller lead wire from terminal 4 on the actuator to keep the valve in the low-fire position.
4. Start the system and establish the main burner flame.
5. Loosen the setscrew in the cam with the special wrench. Keep the wrench seated in the setscrew. Rotate the cam slightly downward (by moving the wrench toward the actuator base) to open the bleed valve. The actuator will start to close.
6. When the valve reaches the desired low-fire position, quickly tighten the setscrew and remove the wrench. If the desired low-fire setting is missed, loosen the setscrew and rotate the cam in the opposite direction to the desired set point.
7. Shut down the burner, and then restart. Repeat several times to be sure the low-fire setting is suitable for correct burner light off. Readjust, if necessary.
8. Disconnect power and reconnect the controller lead wire removed in step 3.

9. Replace the wiring compartment cover.

To adjust low fire on a fully-modulating burner, the butterfly metering valve controls the adjustment means. See Page 134, Figure 107 and Figure 108. There are two types of butterfly metering valves used on these air handlers; the first determines the low fire position by linkage adjustment only, the second has an actual stop screw which controls the flow of gas for low fire. In each case, the low fire flow is adjusted to the smallest flow possible while still achieving the best combustion results. See Page 136, Section 25.9, Step 10 for adjustment information.

FIGURE 107: Low Fire Adjustment for Fully-Modulating Burner with Linkage Adjustment



FIGURE 108: Low Fire Adjustment for Fully-Modulating Burner with Stop Screw Adjustment

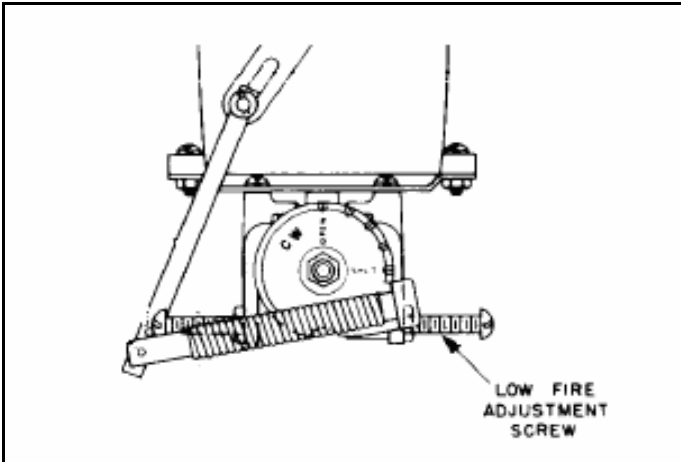

25.8 Oil Pressure Adjustments

All adjustments, for all burner types - on/off, high/low/off and fully-modulating are accomplished by adjusting the oil pump pressure settings. Refer to the pump manufacturer's bulletin packed with the burner.

25.8.1 Oil Pressure Adjustments for On/Off Burner

The on-off system uses a single stage, high suction lift oil pump with a simplex oil nozzle. The nozzle oil flow rate is set by adjusting the oil pump pressure regulating valve. Turn clockwise to increase the pressure and counter-clockwise to decrease the pressure to the nozzle. Normal nozzle pressure will be 100 to 300 PSI (6894 - 20684 mbar). Refer to the burner's manufacturer's manual packed with the burner to determine specific nozzle pressures and firing rates. Nozzle pressures are taken at the nozzle pressure gauge port. The oil on-off flow to the nozzle is controlled by the oil solenoid valve. The combustion air dampers are adjusted and locked in place with the air damper arms. The burner operates at one fixed firing rate.

FIGURE 109: Oil Pressure Adjustments for On/Off Burner

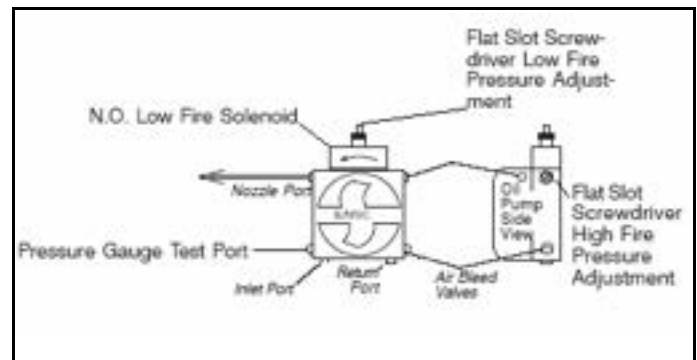

25.8.2 Oil Pressure Adjustments for High/Low Off Burner with Suntec Pump

This low-high-off system uses a two-step oil pump with a simplex oil nozzle in conjunction with movable combustion air dampers to provide a low fire start and a high fire run sequence. Nozzle flow rate pressure is taken at the 1/8" plugged pump pressure gauge port. The low fire oil rate is set by adjusting the oil pump low pressure regulator. The high fire oil flow rate is set by adjusting the oil pump high pressure regulator. For both high and low fires, turn the adjustment screws clockwise to increase the pressure and counterclockwise to decrease the pressure to the nozzle. Approximate low fire oil pressures are 100 to 125 psig (6894 - 8618 mbar) and high fire, 200 to 300 psig (13789 - 20684 mbar).

Both settings will vary depending upon the specific nozzle size selected and job conditions. Refer to the burner's manufacturer's manual packed with the burner to determine specific nozzle pressures and

firing rates.

At light off, the main oil solenoid valves are energized, allowing fuel to the nozzle. A normally open pump mounted oil solenoid valve allows a controlled flow of oil to the nozzle in accordance with the pressure setting of the pump low fire adjustment. When the low fire flame is proven by the flame detector, the pump-mounted, normally open solenoid valve is energized (closes), putting full high fire pump pressure on the nozzle. Simultaneously, the three-way solenoid valve is energized, allowing oil into the hydraulic oil cylinder which mechanically drives the air damper arm to the high fire open position. The burner operates at full high fire until the system demand is satisfied.

FIGURE 110: Oil Pressure Adjustment High/Low/Off Burner with Suntec Pump

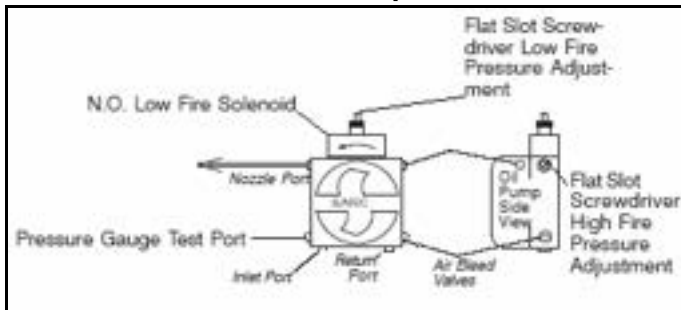

25.8.3 Oil Pressure Adjustments for High/Low/Off Burner with Webster Pump

This high/low/off system uses a two-stage oil pump with a simplex oil nozzle or an internal bypass nozzle in conjunction with movable combustion air dampers to provide a low fire start and a high fire run sequence. Nozzle supply pressure is set by adjusting the oil pump pressure regulator. Turn clockwise to increase the pressure and counter-clockwise to decrease the pressure to the nozzle.

Nozzle supply pressure is taken at the plugged pump nozzle pressure gauge port. Nozzle supply pressure will normally be approximately 300 PSI (20684 mbar) at both high and low firing rates. Flow rate pressure for both high and low fire is taken at bypass pressure gauge tee. Low fire pressures are set by adjusting the low fire regulating valve. Turning the low fire regulating valve adjustment nut clockwise will increase the pressure at the bypass pressure test tee gauge (increasing the low fire input) and counter clockwise will reduce the pressure at the gauge (decreasing the low fire input). Low fire return pressure will normally be in 60 to 100 PSI (4135 -

6894 mbar) range and at high fire in the 180 to 225 PSI (12410 - 15513 mbar) range, but both pressures will vary according to the specific nozzle being used, as well as job conditions.

At light-off, the main oil solenoid valve is energized, allowing fuel to flow to the nozzle. At the same instant a portion of the oil bypasses the nozzle through the adjustable low fire regulating valve, reducing the pressure at the nozzle as required for low fire rates. When the low fire flame is proven by the flame detector, the return oil solenoid valve is de-energized, putting full high fire pump pressure on the nozzle. Simultaneously, the three-way solenoid valve is energized, allowing oil into the hydraulic cylinder which mechanically drives the air damper arm to the high fire position. The burner operates at full high fire until the system demand is satisfied. Refer to the burner's manufacturer's manual packed with the burner to determine specific nozzle pressures and firing rates.

NOTE: Some high/low/off will be supplied with simplex, rather than internal bypass type, oil nozzles. The mechanical operation of the simplex nozzle system is essentially the same as the internal bypass system - except that low fire oil pressures should be set at 100 to 125 psig (6894 - 8618 mbar) (adjust to suit job conditions) and high fire oil pressures at 280 to 300 psig (19305 - 20684 mbar) at the oil pump nozzle pressure gauge test port. Refer to the burner's manufacturer's manual packed with the burner to determine specific nozzle pressures and firing rates.

FIGURE 111: Oil Pressure Adjustments for High/Low/Off Burner with Webster Pump

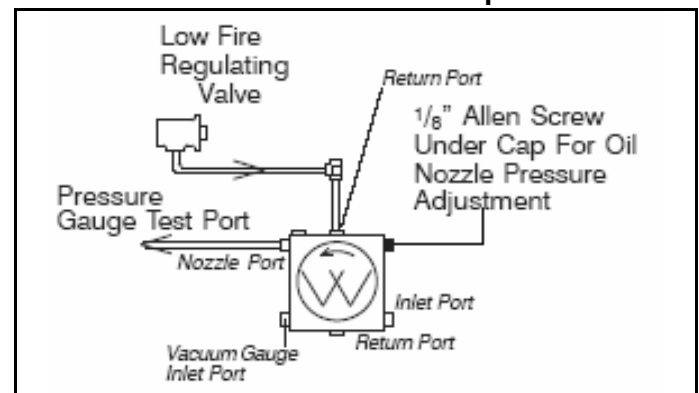

25.8.4 Oil Pressure Adjustments for Fully-Modulating Burner with Webster Pump

The full modulating system uses a two-stage oil pump with an internal bypass type oil nozzle. A modulating actuator controls the positioning of the

combustion air dampers and the modulating oil valve in the nozzle return line through mechanical linkage. At main flame light-off, the normally-closed oil valve is energized, allowing oil to flow to the nozzle. The modulating oil valve is adjusted to allow a controlled amount of oil to bypass the nozzle, which keeps the pressure reduced to the nozzle for low fire light off. Nozzle oil supply pressure is set by adjusting the oil pump pressure regulator. Turn clock-wise to increase the pressure and counter-clockwise to decrease the pressure to the nozzle.

The low fire nozzle pressures should be taken at the oil pump gauge port and should be approximately 300 PSI (20684 mbar) with pressure at the nozzle bypass gauge port from 60 to 100 PSI (4136 - 6894 mbar), these pressures vary with nozzle size and job conditions. A typical low fire oil flow setting on the modulating oil valve would be number 7, but will vary with job conditions. After a brief period of time for the low fire flame to stabilize, the modulating actuator will drive the fuel/air linkage to the high fire position.

At this point, the combustion air dampers will be fully-open (or as required for good combustion) and the modulating oil valve will be at the closed position and the nozzle bypass line will be fully closed, putting full oil pressure to the nozzle. The oil pump pressure gauge port pressure reading will show approximately 300 PSI (20684 mbar) and pressures at the bypass pressure gauge port will be 180 to 225 PSI (12410 - 15513 mbar), although this will vary with the specific nozzle size being used. Refer to the burner's manufacturer's manual packed with the burner to determine specific nozzle pressures and firing rates.

FIGURE 112: Oil Pressure Adjustments for Fully-Modulating Burner with Webster Pump

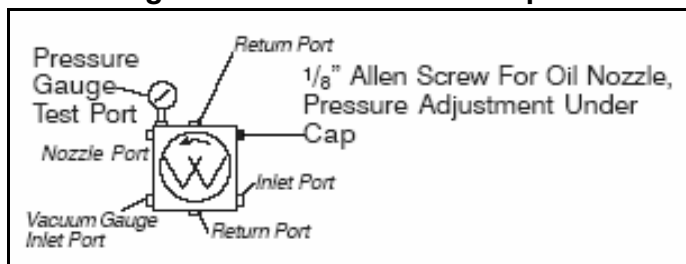

25.9 Gas Fired Equipment Start-Up Procedures

- Review the procedures in this section before proceeding.
- Verify the burner air dampers are approximately 1/4" (.64 cm) open, and with the pilot cock closed, open the main gas cock (to allow the low gas pressure switch, if supplied, to make its circuit).
- Start the burner. With the pilot gas cock closed, the burner will go through a blower pre-purge period, after which the pilot ignition transformer will be energized, although no pilot will be established. At the end of the pilot trial for ignition and blower purge period, the flame safeguard control should shut the system down in a safety lock-out mode, requiring manual reset of the flame safeguard control to restart the burner.
- Reset the flame safeguard control safety switch and open the pilot gas cock. If the flame safeguard control has a timer "Stop/Run" switch, stop the timer while the pilot is on and make adjustments as required once the blower pre-purge period ends and the burner is energized. Refer to the burner manufacturers' bulletin for pilot ignition adjustments. If the flame safeguard control does not have a timer "stop/run" switch, it will be necessary to keep the burner in the pilot light-off position by electrically disconnecting the motorized gas valve or modulating valve to complete pilot adjustments.
- With pilot adjustments completed, reset the timer switch to the "run" position, which will allow the sequence to proceed to the automatic gas valve energizing position. If the motorized gas valve or modulating valve has been disconnected, shut the burner off and reconnect to allow normal operation.
- When the main automatic gas valve begins to open, slowly open the firing gas cock to light off the main flame. The main flame should light immediately. If not, it may be necessary to eliminate air from the main gas line and/or adjust main gas pressure regulator flow rates.
- Adjust the burner as necessary to provide smooth ignition of the main flame. If the flame signal drops significantly when the main automatic gas valve opens, slightly increase the pilot gas pressure to attain a stable flame signal value.
- For on/off burners - adjust the main gas pressure regulator to achieve the proper main flame gas input. Set and lock the air dampers to provide 8.5 to 10% carbon dioxide (CO₂) and 0% carbon monoxide (CO). Make certain the pilot operates reliably at the final fuel/air settings.
- For high/low/off burners - adjust the main gas pressure regulator in combination with the air

damper linkage operation to achieve 8.5 to 10% CO₂ and 0% CO at the full high fire input rate position. Make certain the linkage operates smoothly and without binding or over travel of the air damper stops. Run burner to the low fire position and lock motorized gas valve internal low fire adjustment to a setting that will attain 7 to 9% CO₂ and 0% CO at the desired low fire input rate.

10. For full modulation burners, adjust the main gas pressure regulator in combination with the air damper and metering valve linkage operation to achieve 8.5 to 10% CO₂ and 0% CO at the full high fire input rate position. Run burner to the low fire position and lock the metering valve external adjustment to a setting that will attain 7 to 9% CO₂ and 0% CO at the desired low fire input rate. Check for proper combustion at the midpoint rate (7 to 9% CO₂ and 0% CO) and make sure the linkage operates smoothly and without binding or over travel of the air damper and metering valve stops.
11. Re-check all reset switches - burner relay, limits, pressure cut-off switches, and, if necessary, main fan & burner motor overload reset button(s). Set the room thermostat and/or duct thermostat to the desired temperatures.

NOTE: When firing natural gas and LPG, it is possible to attain CO₂ readings that appear to be acceptable (i.e., 8%, 9%, 10%, etc.) while actually producing an unsafe condition. At such CO₂ readings, a deficiency of air will create the formation of CO (Carbon Monoxide) in the flue gases. Therefore, when firing gas, test for CO to make certain that the burner is adjusted so that it has an excess, rather than a deficiency, of air, CO is a dangerous product of incomplete combustion and is associated with combustion inefficiency and increased fuel cost. 0% CO (Carbon Monoxide) may not be achievable. Readings between 0 and 100 PPM are desirable with the maximum level determined by local codes.

25.10 Oil Fired Equipment Start-Up Procedures

1. Review the procedures in this section before proceeding.
2. Verify the burner air dampers are approximately 1/4" (.64 cm) open and start the burner. The ignition circuit will be energized after the blower pre-purge period has been completed and all limit and other interlock circuits have been closed.
3. The burner is direct spark ignited. Either remove the flame sensor from its sight pipe or electrically disconnect the main oil solenoid valve and start the burner. Regardless of how the burner is started, the flame safeguard control will not detect flame and should go into a safety lockout mode requiring manual reset of the flame safeguard control. There must be no indication of oil pressure at the oil nozzle until the main oil valve is energized through the flame relay.
4. Restart the burner and allow normal sequencing to bring on ignition. Once the main solenoid oil valve is energized, the oil flame should be established immediately. If not, shut the system down and make corrections as required. DO NOT repeatedly recycle the burner, allowing accumulation of unburned fuel in the combustion chamber. **This could result in fire or explosion.**
5. For small "on/off" burners with a simplex nozzle, adjustments consist primarily of attaining correct fuel/air ratios. Adjustments should be set to obtain 11-12% CO₂ and no more than #2 smoke.
6. Fixed air low fire start burners with simplex nozzles require correct fuel/air ratios for high fire and should be set no more than #2 smoke at high fire with 11-12% CO₂. Low fire nozzle pressures are set to achieve smooth light-off with the air dampers fixed in the high fire position.
7. High/low/off burners should have initial adjustments made at the light-off position. After the light-off fuel/air adjustments are made, run the burner to the high fire position and make adjustments as required for good operation. Adjustments should provide 11-12% CO₂ with no more than #2 smoke at high fire and 8-10% CO₂ with no more than a #2 smoke on low fire.
8. For full modulation burners, start adjustments in the low fire position. Adjust the air and fuel linkage to obtain a fuel/air ratio of 8-10% CO₂ and no more than #2 smoke. Mark the linkage for this setting. Increase the firing rate to the mid-fire position. Set the fuel/air ratios to achieve 9-11% CO₂ and no more than #2 smoke. Mark the linkage as a reference point for this mid-fire position. Increase the rate to the high fire position. Results should be 12.5% CO₂ and no more than #2 smoke. Mark this position on the linkage. Operate the modulating arm through the three previously determined reference points. Minor setting changes may be required to ensure that the proper CO₂ and smoke requirements are achieved. Run



the modulating motor through its full travel to ensure that the linkage moves freely and that the travel limits on the metering device and air dampers are not exceeded. Refer to the burner manufacturer's bulletin for oil pump pressure settings.



9. Re-check all reset switches - burner relay, limits, pressure cut-off switches, and, if necessary, main fan & burner motor overload reset button(s). Set the room thermostat and/or duct thermostat to the desired temperatures.

25.11 Accessories and Controls Start-Up

Refer to the separate manufacturer's literature included in the documentation shipped with the air handler for proper set-up and operation of other included accessories and controls.

SECTION 26: MAINTENANCE

⚠ DANGER	
	
<p style="text-align: center;">Electrical Shock Hazard</p> <p>Disconnect electric before service.</p> <p>More than one disconnect switch may be required to disconnect electric from equipment.</p> <p>Equipment must be properly grounded.</p>	<p style="text-align: center;">Severe Injury Hazard</p> <p>Do not enter equipment while in operation.</p> <p>Equipment may start automatically.</p> <p>Do not operate with door open.</p> <p>Installation, operation and service must be done by a trained technician only.</p>
Failure to follow these instructions can result in death, injury or property damage.	

⚠ WARNING		
		
<p style="text-align: center;">Explosion Hazard</p> <p>Leak test all components of equipment gas/oil piping before operation.</p> <p>Gas/oil can leak if piping is not installed properly.</p> <p>Do not high pressure test gas/oil piping with equipment connected.</p>	<p style="text-align: center;">Falling Hazard</p> <p>Use proper safety equipment and practices to avoid falling.</p> <p>Do not use any part of equipment as support.</p>	<p style="text-align: center;">Burn Hazard</p> <p>Allow equipment to cool before service.</p> <p>Internal components of equipment may still be hot after operation.</p>
Failure to follow these instructions can result in death, injury or property damage.		

Prior to any maintenance or service to the air handler, shut off, lockout and tagout, the electrical disconnect and fuel valve that supplies the unit in accordance with OSHA regulations and allow ample time for the air handler to cool. After maintenance is performed or unit is serviced, the unit shall be re-commissioned to the start-up procedure as outlined on *Page 130, Section 25*.

Installation Code and Annual Inspections:

All installation and service of ROBERTS GORDON® equipment must be performed by a contractor qualified in the installation and service of equipment sold and supplied by Roberts-Gordon LLC and

conform to all requirements set forth in the ROBERTS GORDON® manuals and all applicable governmental authorities pertaining to the installation, service, operation and labeling of the equipment.

To help facilitate optimum performance and safety, Roberts-Gordon LLC recommends that a qualified contractor conduct, at a minimum, annual inspections of your ROBERTS GORDON® equipment and perform service where necessary, using only replacement parts sold and supplied by Roberts-Gordon LLC.

26.1 General

First 8 Hours of Operation	Check belts and adjust as required (<i>See Page 131, Section 25.1.2</i>). Though belts were properly adjusted at the factory, they will stretch after the first few hours of operation.
First 100 Hours of Operation	Re-check belt tension and adjust if necessary.
Annual Fall Start-Up	Follow the entire start-up procedure at this time and check control settings and operation.

26.2 Unit Exterior

Cabinet Exterior	After installation, touch up scratches. Periodic painting should be done thereafter as required. The caulk around weather enclosures and over field joints should be inspected annually. Re-apply caulk as needed to maintain integrity.
Unit Location	Verify that no flammable objects, liquids or vapors are present near the air handler. Minimum clearances to combustibles around the vent pipe are significantly higher than for the air handler. <i>See Page 13, Section 3.1</i> . Do not hang anything from or place anything on the air handler. Keep the area under and around the air handler free of all objects.
Heat Exchanger Inspection/Relief Cap	This cap must remain closed at all times. It is opened when the heat exchanger experiences extreme internal pressure. Every six months check for tightness of retaining collar, freeness of hinge movement and hinge spring strength/condition. Replace if cap is not securely held closed.
Ductwork	Check flexible duct connection for deterioration. Repair as required. Minimum temperature rating for flexible duct connections must be 500° F (260° C).
Vent Pipe and Terminals	Look for dirt, obstructions, cracks on the pipe, gaps in the sealed areas and corrosion. Clean or replace as required. Do not use the air handler if there is dirt, sagging, cracking or distortion. Remove any carbon deposits or scale using a wire brush. If applicable, check insulation of vent pipe. Repair as required. Insulation must have a minimum temperature rating of 1000° F (537.8° C).

26.3 Blower Section

Blower Wheel	Inspect blower wheel and clean as necessary. A small build up of dust can cause a significant decrease in blower performance. Check for excessive vibration, repair as required.
Drive Belts and Sheaves	Check for belt ride in the groove. In multiple groove drives, belt ride should be uniform. Check groove wear area for wear. Side wall of groove should be straight, not dished out. Bottom of groove should show no signs of belt contact. Sheave alignment, set screw torque and belt tension should be checked after 8, 24, and 100 hours of initial start-up. Visually inspect belts and sheaves for excessive wear. If belts have a slick, glazed look, the belts are slipping. Check drive capacity and belt tension. Never replace only one belt in a used set, as used belts will elongate. Replace the entire set if replacement is necessary.

**Blower Bearing
Lubrication**

The blower bearings should be re-lubricated every 3,000 hours of operation or 6 months, whichever occurs first. The recommended lubricant is Shell Alvania #2 or S3 grease. To re-lubricate the blower pillow block/flange bearings, be sure that the grease fittings on the bearing housing (or air handler cabinet wall in the case of extended grease lines) are clean. Apply the recommended grease to the fitting with a low-pressure grease gun and add slowly while the shaft is spun by hand. Do not over-grease. Over-greasing will reduce the service life of the bearings.

Motors
Inspection:

1. Inspect motor every 3 months or 500 hours of operation, which ever occurs first. Keep the motor clean and vent openings clear.

Lubrication:

1. Motors with grease fittings must be lubricated based on the table below.

Table 25: Motor Lubrication Intervals

NEMA Frame Size (Motor HP)	Rated at 1800 RPM (Hrs)
Up to 210 (3 - 5)	6,000
Over 210 to 280 (7.5 - 20)	4,750
Over 280 to 360 (25 - 50)	3,700

Note: These intervals are based on severe duty. Over lubricating bearings could result in reduced motor life.

2. A high grade ball or roller bearing grease must be used. Recommended grease for standard service is Polyrex EM (Exxon Mobil). Other compatible greases include; Texaco Polystar, Rykon Premium #2, Pennzoil Pen 2 Lube and Chevron SRI.
3. Motors without grease fittings are sealed for life and do not require re-lubrication.

Instructions for Lubricating

Before greasing, be sure fittings are clean and free from dirt. Remove grease relief plug or plate and, using a low-pressure grease gun, pump in the required grease. Do not over-grease. Relubrication intervals are specified in the table above. After relubricating, allow motor to run for 10 minutes before replacing relief hardware.

NOTE: In general it is not recommended to mix greases of different brands. The mixing of different types of thickeners may destroy the composition and physical properties of the grease. In the event that a different grease is required by the end user, the following steps can be taken. Using the instructions for lubrication, open grease outlet and purge the system as much as possible of the old or unwanted grease. Repeat this same operation after 1 week of service. Consult Roberts-Gordon LLC or the motor manufacturer for further recommendations on grease compatibility.

26.4 Manifold and Controls

Manifold	Periodically check fuel control assembly, and internal and external piping for leaks. Relief vent lines to outdoors on fuel controls should be checked to ensure against blockage caused by insects or any other substance. Clean as required.
Air Flow Switch	An annual check of the tubes attached to the air flow switch should be made to ensure against blockage caused by insects or any other substance. Clean as required.
Electric Components	Check to see there is no physical damage on any of the electric components and verify all electrical connections are secure. Ensure equipment is properly grounded.
Temperature Sensors	Calibrate room, outdoor air, and discharge air sensors as required.

26.5 Burner

An annual inspection of the burner and components must be made to insure proper and safe operation. For the most part, the burner is self cleaning. However, if the application is extremely dirty or dusty, it may become necessary to periodically clean the burner. Refer to the burner manufacturer's literature for guidance.

26.6 Dampers

Check linkage when applicable and tighten set screws as required. All moving parts of dampers should be cleaned and then thoroughly lubricated with light molybdenum oil in aerosol can. Dampers furnished with stainless steel side seals should also have the seals lubricated generously. Dampers should then be manually operated several times until linkages and blades operate freely. Reconnect linkages and check dampers for proper operation.

26.7 Filters

Filters should be checked for dirt restriction on a monthly basis (or as required). Replace filters with filters of equal specification when they appear dirty.

26.8 Motor and Drive Components





Gain access to the blower and motor by removing the belt guard or weather-proof cover. First, release tension on the belts by adjusting the motor base closer to the blower pulley. Remove the belts.

To remove the motor pulley, first loosen the adjustment set screws and count the number of turns to fully close the pulley (this number will be required to re-install the pulleys to the previous adjustment). Open the adjustable sheaves to gain access to the shaft set screws. Loosen the set screw(s) that hold it to the motor shaft and pull away from the motor.

To remove the blower pulley, remove the bolts from the bushing and insert into the previously unused threaded holes of the bushing. Carefully press the blower pulley off the bushing, tightening the bolts evenly. Loosen the Allen Head setscrew (located on top of the keyway) and slide the pulley bushing off the shaft.

To remove the motor, first remove any guards and/or covers around motor and then remove motor pulley as described above. Disconnect the motor power wiring and conduit at the junction box in the side of the motor. Support the motor so that it will be secure when disconnected from the adjustable base. Remove the bolts that hold the motor to the adjustable base. The motor may now be removed.

SECTION 27: REPLACEMENT PARTS

⚠ DANGER		⚠ WARNING	
			
Electrical Shock Hazard	Explosion Hazard	Fire Hazard	Carbon Monoxide Hazard
Use only genuine ROBERTS GORDON® replacement parts per this installation, operation and service manual.			
Failure to follow these instructions can result in death, electric shock, injury or property damage.			

Replacement parts list is for general indirect fired applications and MAY NOT BE APPLICABLE FOR your specific unit configuration. Before ordering replacement parts, please contact factory to make sure that the replacement parts are the direct replacement for your specific unit.

27.1 Replacement Blower Components

Description	Mfg. Model Number	Part Number
BEARING DRIVE- MODELS 35/45	F4B-SXR-115	81900090
BEARING DRIVE- MODELS 50/65	F4B-SXR-103	81900060
BEARING DRIVE- MODELS 75/85/100	F4B-SXR-115	81900090
BEARING DRIVE- MODEL 125	F4B-SXR-115	81900090
BEARING DRIVE- MODELS 150/175	F4B-SXR-115	81900090
BEARING DRIVE- MODELS 200/225	F4B-SXR-115	81900090
BEARING DRIVE- MODELS 250/275/300	F4B-SXR-115	81900090
BEARING DRIVE- MODELS 350/400/450	F4B-SXR-203	81900100
BEARING- MODELS 35/45	F4B-SXR-103	81900060
BEARING- MODELS 50/65	P2B-SXR-103	81900000
BEARING- MODELS 75/85/100	F4B-SXR-103	81900060
BEARING- MODEL 125	F4B-SXR-103	81900060
BEARING- MODELS 150/175	P2B-SXR-103	81900000
BEARING- MODELS 200/225	P2B-SXR-103	81900000
BEARING- MODELS 250/275/300	P2B-SXR-103	81900000
BEARING- MODELS 350/400/450	P2B-SXR-103	81900000
BUSHING, FIXED PULLEY, 0.875"	SD78	82200580
BUSHING, FIXED PULLEY, 1.1875"	SD1316	14153100
BUSHING, FIXED PULLEY, 1.4375"	SD1716	82200590
BUSHING, FIXED PULLEY, 1.5"	SD150	82200595
BUSHING, FIXED PULLEY, 1.9375"	SD11516	14142800
BUSHING, FIXED PULLEY, 1.625"	SD158	82200600
BUSHING, FIXED PULLEY, 1.875"	SD178	82200620
BUSHING, FIXED PULLEY, 1.25"	SDS114	82200470
BUSHING, FIXED PULLEY, 1.6875"	SDS11116	82200520
BUSHING, FIXED PULLEY, 1.5"	SDS112	82200550
BUSHING, FIXED PULLEY, 1.9375"	SDS11516	82200540
BUSHING, FIXED PULLEY, 13/16"	SDS1316	82200480
BUSHING, FIXED PULLEY, 1.375"	SDS138	82200490
BUSHING, FIXED PULLEY, 1.625"	SDS158	82200510
BUSHING, FIXED PULLEY, 1.4375"	SDS1716	82200500
BUSHING, FIXED PULLEY, 1.4375"	SF1716	14130500
BUSHING, FIXED PULLEY, 1.6875"	SF11116	82200830
BUSHING, FIXED PULLEY, 1.9375"	SF11516	82200840

Description	Mfg. Model Number	Part Number
BUSHING, FIXED PULLEY, 1.625"	SF158	82200850
BUSHING, FIXED PULLEY, 2.9375"	SF21516	82200900
BUSHING, FIXED PULLEY, 2.6875"	SF21116	14173900
BUSHING, FIXED PULLEY, 2.125"	SF218	82201000
BUSHING, FIXED PULLEY, 2.1875"	SF2316	82200860
BUSHING, FIXED PULLEY, 2.375"	SF238	14071000
BUSHING, FIXED PULLEY, 2.4375"	SF2716	82200870
BUSHING, FIXED PULLEY, 2.875"	SF278	82200880
BUSHING, FIXED PULLEY, 0.75"	SH75	14220000
BUSHING, FIXED PULLEY, 1.1875"	SH1316	82200420
BUSHING, FIXED PULLEY, 1.6875"	SH1688	82210700
BUSHING, FIXED PULLEY, 1.375"	SH138	82200430
BUSHING, FIXED PULLEY, 1.625"	SH158	82200450
BUSHING, FIXED PULLEY, 1.4375"	SH1716	82200440
BUSHING, FIXED PULLEY, 1.375"	SK1375	82200670
BUSHING, FIXED PULLEY, 1.6875"	SK11116	82200700
BUSHING, FIXED PULLEY, 1.5"	SK112	82201030
BUSHING, FIXED PULLEY, 1.9375"	SK11516	82200720
BUSHING, FIXED PULLEY, 1.125"	SK118	82201020
BUSHING, FIXED PULLEY, 1.1875"	SK1316	82200660
BUSHING, FIXED PULLEY, 1.625"	SK158	82200690
BUSHING, FIXED PULLEY, 1.4375"	SK1716	82200680
BUSHING, FIXED PULLEY, 1.875"	SK178	82200710
BUSHING, FIXED PULLEY, 2.1875"	SK2188	82200740
BUSHING, FIXED PULLEY, 2.4375"	SK2438	82200750
BUSHING, FIXED PULLEY, 2.6875"	SK2688	82200760
BUSHING, FIXED PULLEY, 2.125"	SK218	82200730
BUSHING, FIXED PULLEY, 2.375"	SK238	82201010
BUSHING, MODELS 50/65	QA 1 3/16	14052100
COUPLING W/EPDM SLEEVE- MODELS 50/65	6B	14052000
PULLEY, FIXED-1B X 11.0 1-3/16	-	82105120
PULLEY, FIXED-1B X 11.0 PD SDS	-	14093210
PULLEY, FIXED-1B X 12.4 1-3/16	-	82105140
PULLEY, FIXED-1B X 12.4 PD SDS	-	14189300
PULLEY, FIXED-1B X 13.6 1-3/16	-	82105150
PULLEY, FIXED-1B X 13.6 PD SDS	-	82105160
PULLEY, FIXED-1B X 16.0 PD SDS	-	82100270
PULLEY, FIXED-1B X 18.4 PD SK	-	82100280
PULLEY, FIXED-1B X 20.0 PD SK	-	82100290
PULLEY, FIXED-1B x 3.4 PD 1-3/16"	-	14129000
PULLEY, FIXED-1B X 3.6 PD SH	-	14228902
PULLEY, FIXED-1B X 4.0 PD 1-3/16	-	14106400
PULLEY, FIXED-1B X 4.2 PD SH	-	14228903
PULLEY, FIXED-1B X 4.6 PD 1-3/16	-	14118900
PULLEY, FIXED-1B X 40 SH	-	14087110
PULLEY, FIXED-1B X 5.0 PD 5/8	-	14087100
PULLEY, FIXED-1B X 5.2 PD SDS	-	14110800
PULLEY, FIXED-1B X 5.8 1-3/16	-	82100110
PULLEY, FIXED-1B X 6.0 SDS	-	14120410
PULLEY, FIXED-1B X 6.2 PD SDS	-	14228904
PULLEY, FIXED-1B X 6.8 1-3/16	-	82105060
PULLEY, FIXED-1B X 7.4 1-3/16	-	82105070
PULLEY, FIXED-1B X 7.4 PD SDS	-	82100180
PULLEY, FIXED-1B X 8.6 1-3/16	-	82105080
PULLEY, FIXED-1B X 9.4 PD SDS	-	82100220
PULLEY, FIXED-2B X 11.0 PD SK	-	82100560
PULLEY, FIXED-2B X 12.4 PD SK	-	82100570
PULLEY, FIXED-2B X 13.6 PD SK	-	82100580
PULLEY, FIXED-2B X 15.4 PD SK	-	82100590
PULLEY, FIXED-2B X 16.0 PD SK	-	82100600
PULLEY, FIXED-2B X 18.4 PD SK	-	82100610
PULLEY, FIXED-2B X 20.0 PD SF	-	82100620

Description	Mfg. Model Number	Part Number
PULLEY, FIXED-2B X 25.0 SF	-	82100630
PULLEY, FIXED-2B X 3.4 PD SH	-	14228901
PULLEY, FIXED-2B X 4.2 PD SH	-	82100360
PULLEY, FIXED-2B X 4.4 PD SH	-	82100370
PULLEY, FIXED-2B X 4.6 PD SDS	-	82100380
PULLEY, FIXED-2B X 4.8 PD SDS	-	82100390
PULLEY, FIXED-2B X 5.2 PD SDS	-	82100410
PULLEY, FIXED-2B X 5.4 PD SDS	-	82100420
PULLEY, FIXED-2B X 5.6 PD SDS	-	82100430
PULLEY, FIXED-2B X 5.8 PD SDS	-	82100440
PULLEY, FIXED-2B X 6.0 PD SDS	-	82100450
PULLEY, FIXED-2B X 6.2 PD SDS	-	82100460
PULLEY, FIXED-2B X 6.4 PD SDS	-	82100470
PULLEY, FIXED-2B X 6.6 PD SDS	-	82100480
PULLEY, FIXED-2B X 6.8 PD SDS	-	82100490
PULLEY, FIXED-2B X 7.0 PD SK	-	82100500
PULLEY, FIXED-2B X 7.4 PD SK	-	82100510
PULLEY, FIXED-2B X 8.0 PD SK	-	82100520
PULLEY, FIXED-2B X 8.6 PD SK	-	82100530
PULLEY, FIXED-2B X 9.4 PD SK	-	82100550
PULLEY, FIXED-3B X 5.2 PD SD	-	82100740
PULLEY, FIXED-3B X 11.0 PD SK	-	82100890
PULLEY, FIXED-3B X 12.4 PD SK	-	82100900
PULLEY, FIXED-3B X 13.6 PD SK	-	82100910
PULLEY, FIXED-3B X 15.4 PD SK	-	82100930
PULLEY, FIXED-3B X 18.4 PD SK	-	82100940
PULLEY, FIXED-3B X 20.0 PD SF	-	82100950
PULLEY, FIXED-3B X 25.0 PD SF	-	82100960
PULLEY, FIXED-3B X 30.0 PD SF	-	82100970
PULLEY, FIXED-3B X 31.5 PD SH	-	14120900
PULLEY, FIXED-3B X 4.4 PD SD	-	82100700
PULLEY, FIXED-3B X 4.6 PD SD	-	82100710
PULLEY, FIXED-3B X 4.8 PD SD	-	82100720
PULLEY, FIXED-3B X 5.0 PD SD	-	82100730
PULLEY, FIXED-3B X 5.4 PD SD	-	82100750
PULLEY, FIXED-3B X 5.6 PD SD	-	82100760
PULLEY, FIXED-3B X 5.8 PD SD	-	82100770
PULLEY, FIXED-3B X 6.0 PD SD	-	82100780
PULLEY, FIXED-3B X 6.2 PD SD	-	82100790
PULLEY, FIXED-3B X 6.4 PD SD	-	82100800
PULLEY, FIXED-3B X 6.6 PD SD	-	82100810
PULLEY, FIXED-3B X 6.8 PD SD	-	82100820
PULLEY, FIXED-3B X 7.0 PD SF	-	14209910
PULLEY, FIXED-3B X 7.0 PD SK	-	82100830
PULLEY, FIXED-3B X 7.4 PD SK	-	82100840
PULLEY, FIXED-3B X 8.0 PD SD	-	82100750
PULLEY, FIXED-3B X 8.0 PD SF	-	14225100
PULLEY, FIXED-3B X 8.6 PD SK	-	82100860
PULLEY, FIXED-3B X 9.4 PD SK	-	82100880
PULLEY, FIXED-4B X 11.0 PD SK	-	82101220
PULLEY, FIXED-4B X 12.4 PD SK	-	82101230
PULLEY, FIXED-4B X 13.6 PD SK	-	82101240
PULLEY, FIXED-4B X 15.4 PD SF	-	82101250
PULLEY, FIXED-4B X 16.0 PD SF	-	82101260
PULLEY, FIXED-4B X 18.4 PD SF	-	82101270
PULLEY, FIXED-4B X 20.0 PD SF	-	82101280
PULLEY, FIXED-4B X 5.2 PD SD	-	14100400
PULLEY, FIXED-4B X 5.6 PD SD	-	14188400
PULLEY, FIXED-4B X 5.8 PD SD	-	82101100
PULLEY, FIXED-4B X 6.0 PD SD	-	82101110
PULLEY, FIXED-4B X 6.2 PD SD	-	82101120
PULLEY, FIXED-4B X 6.4 PD SD	-	82101130

Description	Mfg. Model Number	Part Number
PULLEY, FIXED-4B X 6.6 PD SD	-	82101140
PULLEY, FIXED-4B X 6.8 PD SD	-	82101150
PULLEY, FIXED-4B X 7.0 PD SK	-	82101160
PULLEY, FIXED-4B X 7.4 PD SK	-	82101170
PULLEY, FIXED-4B X 8.0 PD SK	-	82101180
PULLEY, FIXED-4B X 8.6 PD SK	-	82101190
PULLEY, FIXED-4B X 9.4 PD SK	-	82101210
PULLEY, VARIABLE- 1B X 3.1 -4.1 1-1/8"	-	82105560
PULLEY, VARIABLE- 1B X 3.1-4. 1 7/8"	-	82105550
PULLEY, VARIABLE- 1B x 3.7-4.7 1-1/8"	-	82105580
PULLEY, VARIABLE- 1B x 4.3-5.3 1-7/8"	-	82101560
PULLEY, VARIABLE- 1B x 4.3-5.3 5/8"	-	82101540
PULLEY, VARIABLE- 1B x 4.3-5.3 7/8"	-	82101550
PULLEY, VARIABLE- 1B x 4.6-5.6 7/8"	-	82101650
PULLEY, VARIABLE- 1B x 4.9-5.9 1-1/8"	-	82101620
PULLEY, VARIABLE- 1B x 4.9-5.9 1-1/8"	-	82105610
PULLEY, VARIABLE- 1B x 4.9-5.9 1-3/8"	-	82105610
PULLEY, VARIABLE- 1B x 4.9-5.9 5/8"	-	82107620
PULLEY, VARIABLE- 1B x 4.9-5.9 7/8"	-	82101610
PULLEY, VARIABLE- 1B x 5.0-6.5 1-3/8"	-	82105930
PULLEY, VARIABLE- 1B x 6.0-7.4 1-1/8"	-	82101630
PULLEY, VARIABLE- 1B X 6.3-7.3 1-1/8"	-	14128900
PULLEY, VARIABLE- 2B X 3.5-4.9 1-3/8"	-	82101810
PULLEY, VARIABLE- 2B X 3.5-4.9 7/8"	-	82101790
PULLEY, VARIABLE- 2B X 4.3-5.3 1-3/8"	-	82101890
PULLEY, VARIABLE- 2B X 4.3-5.4 1-3/8"	-	14228905
PULLEY, VARIABLE- 2B X 4.5-5.9 1- 1/8"	-	82101910
PULLEY, VARIABLE- 2B X 4.5-5.9 1-3/8"	-	82101920
PULLEY, VARIABLE- 2B X 4.5-5.9 1-5/8"	-	82101930
PULLEY, VARIABLE- 2B X 4.5-6.3 1-1/8"	-	82101950
PULLEY, VARIABLE- 2B X 4.9-5.9 1-3/8"	-	82101960
PULLEY, VARIABLE- 2B X 4.9-5.9 1-5/8"	-	82101970
PULLEY, VARIABLE- 2B X 4.9-5.9 7/8"	-	82101940
PULLEY, VARIABLE- 2B X 4.9-6.3 1"	-	14105900
PULLEY, VARIABLE- 2B X 5.0-6.4 1-1/8"	-	82102170
PULLEY, VARIABLE- 2B X 5.0-6.4 1-3/8"	-	82102180
PULLEY, VARIABLE- 2B X 5.5-6.6 1-3/8"	-	82102120
PULLEY, VARIABLE- 2B X 5.5-6.6 1-5/8"	-	82102130
PULLEY, VARIABLE- 2B X 5.5-6.9 1-5/8"	-	82102670
PULLEY, VARIABLE- 2B X 5.6-6.6 1-3/8"	-	82105850
PULLEY, VARIABLE- 2B X 5.8-6.9 1-1/8"	-	82102210
PULLEY, VARIABLE- 2B X 6.0-7.4 1-1/8"	-	82102010
PULLEY, VARIABLE- 2B X 6.0-7.4 1-3/8"	-	82102190
PULLEY, VARIABLE- 2B X 6.0-7.4 1-5/8"	-	82102200
PULLEY, VARIABLE- 2B X 7.0-8.4 1-3/8"	-	14154300
PULLEY, VARIABLE- 2B X 8.0-9.4 1-3/8"	-	82102230
PULLEY, VARIABLE- 2B X 8.0-9.4 1-5/8"	-	82102240
PULLEY, VARIABLE- 2B X5.0-6.4 1-5/8"	-	82102030
PULLEY, VARIABLE- 3B X 4.0-5.4 1-5/8"	-	82102290
PULLEY, VARIABLE- 3B X 4.5-5.9 1-3/8"	-	82102310
PULLEY, VARIABLE- 3B X 4.5-5.9 1-5/8"	-	82102320
PULLEY, VARIABLE- 3B X 4.5-5.9 1-7/8"	-	82102321
PULLEY, VARIABLE- 3B X 4.9-5.9 1-1/8"	-	82102300
PULLEY, VARIABLE- 3B X 5.0-6.4 1-5/8"	-	82102350
PULLEY, VARIABLE- 3B X 5.5-6.9 1-3/8"	-	14153800
PULLEY, VARIABLE- 3B X 5.5-6.9 1-5/8"	-	82102390
PULLEY, VARIABLE- 3B X 5.5-6.9 1-7/8"	-	82102400
PULLEY, VARIABLE- 3B X 6.0-7.4 1-5/8"	-	14228917
PULLEY, VARIABLE- 3B X 6.0-7.4 1-7/8"	-	82102420
PULLEY, VARIABLE- 3B X 6.0-7.4 2-2/16"	-	82102510
PULLEY, VARIABLE- 3B X 7.0-8.4 1-5/8"	-	82102450
PULLEY, VARIABLE- 3B X 7.0-8.4 1-7/8"	-	14122800

Description	Mfg. Model Number	Part Number
PULLEY, VARIABLE- 3B X 8.0-9.4 1-7/8	-	82102500
PULLEY, VARIABLE- 4B X 4.5-5.9 1-5/8	-	14228912
PULLEY, VARIABLE- 4B X 4.5-5.9 1-7/8	-	82102610
PULLEY, VARIABLE- 4B X 5.0-6.4 1-5/8	-	82102640
PULLEY, VARIABLE- 4B X 5.5-6.9 1-7/8	-	82102680
PULLEY, VARIABLE- 4B X 6.0-7.4 1-5/8	-	82102701
PULLEY, VARIABLE- 4B X 6.0-7.4 1-7/8	-	82102700
PULLEY, VARIABLE- 4B X 6.0-7.4 2-1/8	-	82102710
PULLEY, VARIABLE- 4B X 7.0-8.4 1-7/8	-	14125200
PULLEY, VARIABLE- 4B X 7.0-8.4 2-1/8	-	82102750
PULLEY, VARIABLE- 4B X 8.0-9.4 2-1/8	-	82102790
PULLEY, VARIABLE- 4B X 8.0-9.4 2-3/8	-	14124700
PULLEY, VARIABLE- 4B X 8.9-9.4 1-7/8	-	14228913
SHAFT, 1 3/16 x 28 TG&P- 50/65	-	77017006
SHAFT, 1 3/16 x 42- 50/65	-	32585000
SHAFT, 110"- MODELS 200/225	-	30315401
SHAFT, 110"- MODELS 250/275/300	-	30315401
SHAFT, 152"- MODELS 350/400/450	-	30315701
SHAFT, 71"- MODELS 35/45	-	30315600
SHAFT, 83"- MODELS 75/85/100	-	30315503
SHAFT, 96"- MODEL 125	-	30315504
SHAFT, 98"- MODELS 150/175	-	30315403
WHEEL, 12"- MODELS 50/65	0084033P	82000000
WHEEL, 15"- MODELS 35/45	012837-12P	10807701
WHEEL, 15"- MODELS 75/85/100	012837-12P	10807701
WHEEL, 18"- MODELS 125	012838-21P	10807702
WHEEL, 20"- MODELS 150/175	05031504C	10807703
WHEEL, 25"- MODELS 200/225	05031804J	10807704
WHEEL, 25"- MODELS 250/275/300	05031804J	10807704
WHEEL, 30"- MODELS 350/400/450	05032008J	10807705

27.2 Replacement V-Belts

Description	Part Number
V-BELT B-036	33689436
V-BELT B-040	33689440
V-BELT B-041	33689441
V-BELT B-042	33689402
V-BELT B-043	33689443
V-BELT B-044	33689444
V-BELT B-045	33689445
V-BELT B-046	33689446
V-BELT B-047	33689447
V-BELT B-048	33689448
V-BELT B-050	33689450
V-BELT B-052	33689452
V-BELT B-053	33689453
V-BELT B-054	33689454
V-BELT B-057	33689457
V-BELT B-058	33689458
V-BELT B-060	33689460
V-BELT B-062	33689462
V-BELT B-063	33689463
V-BELT B-064	33689464
V-BELT B-065	33689465
V-BELT B-066	33689466
V-BELT B-067	33689467
V-BELT B-068	33689468
V-BELT B-069	33689469
V-BELT B-070	33689470
V-BELT B-071	33689471
V-BELT B-072	33689472
V-BELT B-073	33689473

Description	Part Number
V-BELT B-074	33689474
V-BELT B-075	33689475
V-BELT B-076	33689476
V-BELT B-077	33689477
V-BELT B-078	33689478
V-BELT B-079	33689479
V-BELT B-080	33689480
V-BELT B-081	33689481
V-BELT B-082	33689482
V-BELT B-083	33689483
V-BELT B-084	33689484
V-BELT B-085	33689485
V-BELT B-086	33689486
V-BELT B-088	33689488
V-BELT B-089	33689489
V-BELT B-090	33689490
V-BELT B-091	33689491
V-BELT B-092	33689492
V-BELT B-093	33689493
V-BELT B-094	33689494
V-BELT B-095	33689495
V-BELT B-096	33689496
V-BELT B-097	33689497
V-BELT B-099	33689499
V-BELT B-100	33689400
V-BELT B-101	33689401
V-BELT B-103	33689403
V-BELT B-104	33689404
V-BELT B-105	33689405
V-BELT B-108	33689408
V-BELT B-112	33689412
V-BELT B-115	33689415
V-BELT B-120	33689420
V-BELT B-128	33689428
V-BELT B-150	33689411
V-BELT B-154	33689413
V-BELT BX-49	33689549
V-BELT BX-50	33689550
V-BELT BX-51	33689551
V-BELT BX-52	33689552
V-BELT BX-62	33689562
V-BELT BX-64	33689564
V-BELT BX-65	33689565
V-BELT BX-67	33689567
V-BELT BX-70	33689570
V-BELT BX-72	33689572
V-BELT BX-76	33689576
V-BELT BX-77	33689577
V-BELT BX-78	33689578
V-BELT BX-80	33689580
V-BELT BX-81	33689581
V-BELT BX-82	33689582
V-BELT BX-83	33689583
V-BELT BX-84	33689584
V-BELT BX-85	33689585
V-BELT BX-86	33689586
V-BELT BX-87	33689587
V-BELT BX-88	33689588
V-BELT BX-90	33689590
V-BELT BX-93	33689593
V-BELT BX-95	33689595
V-BELT BX-96	33689596

Description	Part Number
V-BELT BX-97	33689597
V-BELT BX-98	33689598
V-BELT BX-99	33689599
V-BELT BX-100	33689500
V-BELT BX-103	33689501
V-BELT BX-105	33689505
V-BELT BX-108	33689508
V-BELT BX-113	33689513
V-BELT BX-116	33689516
V-BELT BX-117	33689517
V-BELT BX-120	33689520
V-BELT BX-128	33689528
V-BELT BX-133	33689533

27.3 Replacement Damper Components

Description	Mfg. Model Number	Part Number
ACTUATOR POSITIONER - PANEL MOUNT	SGF24	14297900
ACTUATOR POSITIONER - PANEL MOUNT	205860	14321550
AUXILIARY SWITCH PACKAGE	SW2-US	14321551
COVER TRANSFORMER 120VOLT TO 24VOLT	5001746-003	11136204
CRANK ARM KIT	ZGAF	16025200
CRANK/ARM ADP KIT FOR SM MOTORS	ZG-AM	14286201
CRANKARM (FOR FOOT MOUNT ACTUATORS)	221455A	14160800
CRANKARM ADAPT/NM	ZGNM3	14286200
CRANKARM, LONG (BARBER COLEMAN)	AM-113-1/2	81100050
CRANKARM, SHORT (BARBER COLEMAN)	AM-757-1/2	81100051
CRANKARMW/BRACKET AF/NF	ZG-AF108	14300800
DAMPER END SWITCH FOR NM 1SPDT	S1A	14283701
DAMPER END SWITCH FOR SM/GM 1SPDT	SN1	14283700
DAMPER END SWITCH FOR SM/GM2SPDT	S2A	14283702
DAMPER END SWITCH MOTORS/2SPDT	SN2	14283703
FOOT MOUNT KIT (DIRECT DRIVE ACTUATOR)	5000D1194-001	14321560
MOUNT SM/GM/MOTOR	ZG103	14300801
MOUNT/BRACK/NM	ZG105	14300802

27.4 Replacement Burner Components

Description	Mfg. Model Number	Part Number
ADIABATIC CHAMBER FOR JR15/30	J20913	143132-16
ADIABATIC CHAMBER FOR JR50	J20914	143132-17
AIRFLOW SWITCH	17101	83100003
ELECTRODE, FLAME ROD	F10327	14117000
ELECTRODE, SPARK (JACOB LADDER) (OIL - 2 REQ'D)	X04220	14117101
ELECTRODE, SPARK ROD (GAS)	X04210	14117100
GASKET KIT, HTD REPLACEMENT - J15	-	33694011
GASKET KIT, HTD REPLACEMENT - J30	33694012	33694012
GASKET KIT, HTD REPLACEMENT - J50	33694013	33694013
MOTOR 1/3HP - 115-230/1/60 - JR30/50	05412	143132-22
MOTOR 1/3HP - 200-208/3/60 - JR15/30/50	05413R	143132-25
MOTOR 1/3HP - 208-230-460/3/60 - JR15/30/50	05413	143132-28
MOTOR 1/4HP - 115/1/60 - JR15	05000	143132-21
MOTOR 3/4HP - 115/230/1/60 - CR2	05418	143132-23
ORFICE, PILOT, NATURAL GAS - C1 AND 2	X04350-36	14281201
ORIFICE, PILOT, LPG GAS - C1 AND 2	X04350-48	14281203
ORIFICE, PILOT, LPG GAS - C3,4,5	X04350-48	14281204
ORIFICE, PILOT, NATURAL GAS - C3,4,5	X04350-30	14281202
PILOT ASSEMBLY/FLAME ROD W/NAT ORFICE- JR15/30	F30031	143132-01
PILOT ASSEMBLY/FLAME ROD W/NAT ORFICE- JR50	F30041	143132-02
PILOT ASSEMBLY/UV MOUNT W/NAT-LP ORFICE- JR15/30	F31008	143132-03
PILOT ASSEMBLY/UV MOUNT W/NAT-LP ORFICE- JR50	F31009	143132-04

Description	Mfg. Model Number	Part Number
SEALED COMBUSTION AIR INTAKE COLLAR JR15/30	J20502	143132-11
SEALED COMBUSTION AIR INTAKE COLLAR JR50	J20505	143132-13

27.5 Replacement Manifold Components

Description	Mfg. Model Number	Part Number
BUTTERFLY VALVE - 1" (ECLIPSE FULL PORT)	4BV-AB	13591019
BUTTERFLY VALVE - 1" (ECLIPSE REDUCED PORT)	4BV-ARB	13591011
BUTTERFLY VALVE - 1.25" (ECLIPSE REDUCED PORT)	5BV-ARB	N/A
BUTTERFLY VALVE - 1.25" (ECLIPSE FULL PORT)	5BV-AB	N/A
BUTTERFLY VALVE - 1.5" (ECLIPSE FULL PORT)	6BV-AB	13591018
BUTTERFLY VALVE - 1.5" (ECLIPSE REDUCED PORT)	6BV-ARB	13591013
BUTTERFLY VALVE - 2" (ECLIPSE FULL PORT)	8BV-AB	13591015
BUTTERFLY VALVE - 2" (ECLIPSE REDUCED PORT)	8BV-ARB	N/A
BUTTERFLY VALVE - 2.5" (ECLIPSE FULL PORT)	10BV-AB	N/A
BUTTERFLY VALVE - 2.5" (ECLIPSE REDUCED PORT)	10BV-ARB	13591006
BUTTERFLY VALVE- 1" (MIDCO)	MBF-100	14042301
BUTTERFLY VALVE- 1.25" (MIDCO)	MBF-125	14042302
BUTTERFLY VALVE- 1.5" (MIDCO)	MBF-150	14042303
BUTTERFLY VALVE- 2" (MIDCO)	MBF-200	14042304
BUTTERFLY VALVE- 2.5" (MIDCO)	MBF-250	14174100
HIGH/LOW MOTORIZED ACTUATOR	V4062A1123	10978600
MANUAL SHUT OFF VALVE- 1"	BV250-88	82580010
MANUAL SHUT OFF VALVE- 1.25"	BV250-1010	82580020
MANUAL SHUT OFF VALVE- 1.5"	BV250-1212	82580030
MANUAL SHUT OFF VALVE- 2"	BV250-1616	82580040
MANUAL SHUT OFF VALVE- 2.5"	BV250-2020	82580050
MANUAL SHUT OFF VALVE- 3/8"	BV250-33	82580260
MOTORIZED HIGH/LOW VALVE BODY-1"	V5055B1002	11002500
MOTORIZED HIGH/LOW VALVE BODY-1.25"	V5055B1010	14047900
MOTORIZED HIGH/LOW VALVE BODY-1.5"	V5055B1028	14043901
MOTORIZED HIGH/LOW VALVE BODY-2"	V5055B1069	10978600
MOTORIZED PROOF OF CLOSURE ACTUATOR	V4055D1001	83400301
MOTORIZED PROOF OF CLOSURE VALVE BODY-1"	V5055C1034	82585171
MOTORIZED PROOF OF CLOSURE VALVE BODY-1.25"	V5055C1042	82585301
MOTORIZED PROOF OF CLOSURE VALVE BODY-1.5"	V5055C1059	82585291
MOTORIZED PROOF OF CLOSURE VALVE BODY-2"	V5055C1000	82585261
MOTORIZED PROOF OF CLOSURE VALVE BODY-2.5"	V5055C1018	82585361
MOTORIZED VALVE BODY-1"	V5055A1002	82580171
MOTORIZED VALVE BODY-1.25"	V5055A1012	82580181
MOTORIZED VALVE BODY-1.5"	V5055A1020	82580191
MOTORIZED VALVE BODY-2"	V5055A1038	82580201
MOTORIZED VALVE BODY-2.5"	V5055A1046	82580211
MOTORIZED VALVE BODY-3"	V5055A1053	82580221
ON/OFF MOTORIZED ACTUATOR	V4055A1007	83400001
ON/OFF MOTORIZED ACTUATOR (SHAFT)	V4055A1064	11005800
REGULATOR 3/8	325-3	14036300
REGULATOR 1"	RV61	82600030
REGULATOR 1.25"	RV61	82600040
REGULATOR 1.5"	RV81	82600060
REGULATOR 2"	RV91	82600070
REGULATOR 2.5"	RV91	82600080
SOLENOID VALVE, POSITION INDICATION-1"	1" JB821450VI	82500032
SOLENOID VALVE, POSITION INDICATION-1.25"	1.25" JB821460VI	82500041
SOLENOID VALVE, POSITION INDICATION-1.5"	1.5" JB821470VI	82500051
SOLENOID VALVE, POSITION INDICATION-2"	2" JB821480VI	82500061
SOLENOID VALVE-1"	JB821450	82500031
SOLENOID VALVE-1.25"	JB821460	82500040
SOLENOID VALVE-1.5"	JB821470	10762900
SOLENOID VALVE-2"	JB821480	82500060
SOLENOID VALVE-3/8" (PILOT)	L8040H8	14036400

Description	Mfg. Model Number	Part Number
SOLENOID VENT VALVE-1"	JB821453	82500110
SOLENOID VENT VALVE-1.25"	8215C63	82500120
SOLENOID VENT VALVE-1.5"	8215C73	11056500
SOLENOID VENT VALVE-3/4"	8215G33	82500280

27.6 Replacement Electrical Components

Description	Mfg. Model Number	Part Number
AMPLIFIER-FLAME ROD	R7847A1033	15159802
AMPLIFIER-ULTRAVIOLET	R7851B1000	15159805
DISPLAY MODULE	S7800A1001	15160006
FLAME RELAY SUB-BASE- CHASSIS & KNOCKOUT BASE	Q7800B1003	15160000
FLAME RELAY SUB-BASE- CHASSIS ONLY	Q7800B1005	15160001
FLAME SAFEGUARD RELAY MODULE	RM7897A1002	15159600
FLAME SAFEGUARD RELAY MODULE	RM7800L1053	15159603
PURGE TIMER-60 SEC	ST7800A1054	15159702
PURGE TIMER-90 SEC	ST7800A1062	15159703
ULTRAVIOLET SENSOR-MINUS 40 TO 215 DEG	C7027A1031	15180900
CONTROLLER (ELECTRONIC)	T7350M1008	14265160
CONTROLLER (ELECTRONIC) DISCHARGE AIR SENSOR	C7041B2005	14302802
CONTROLLER (ELECTRONIC) OUTSIDE AIR SENSOR	C7031G2014	14303001
DUCTSTAT - 2 STAGE	T678A1015	11113200
DUCTSTAT - MODULATION	T991A1004	83200100
DUCTSTAT - ON/OFF	T675A1508	83200002
ECONOMIZER (ELECTRONIC)	W7212	11006003
ECONOMIZER SENSOR MIXED AIR (ELECTRONIC)	C7046A	14302801
ECONOMIZER SENSOR OUTSIDE AIR (ELECTRONIC)	RTD	14302803
MODULATION CONTROLLER (ELECTRONIC)	T775U2016	14302815
MODULATION DUCT STAT SENSOR	RTD	14302827
MODULATION ROOM STAT SENSOR	RTD	14302831
ROOM THERMOSTAT - 2 STAGE	T25A-1C	83200192
ROOM THERMOSTAT - ON/OFF	T451A2007	83200050
CONTACTOR- 115 AMPS	LC1D115G7	14320710
CONTACTOR- 150 AMPS	LC1D150G7	14320711
CONTACTOR- 18 AMPS	LC1D18G7	14320703
CONTACTOR- 25 AMPS	LC1D25G7	14320704
CONTACTOR- 32 AMPS	LC1D32G7	14320705
CONTACTOR- 40 AMPS	LC1D40G7	14320706
CONTACTOR- 50 AMPS	LC1D50G7	14320707
CONTACTOR- 65 AMPS	LC1D65G7	14320708
CONTACTOR- 80 AMPS	LC1D80G7	14320709
MOTOR PROTECTOR, ROTARY-.63-1 AMPS	GV2P05	14320505
MOTOR PROTECTOR, ROTARY- 1.6-2.5 AMPS	GV2P07	14320507
MOTOR PROTECTOR, ROTARY- 1-1.6 AMPS	GV2P06	14320506
MOTOR PROTECTOR, ROTARY- 13-18 AMPS	GV2P20	14320520
MOTOR PROTECTOR, ROTARY- 17-23 AMPS	GV2P21	14320521
MOTOR PROTECTOR, ROTARY- 2.5-4 AMPS	GV2P08	14320508
MOTOR PROTECTOR, ROTARY- 20-25 AMPS	GV2P22	14320522
MOTOR PROTECTOR, ROTARY- 24-32 AMPS	GV2P32	14320532
MOTOR PROTECTOR, ROTARY- 4-6.3 AMPS	GV2P10	14320510
MOTOR PROTECTOR, ROTARY- 6-10 AMPS	GV2P14	14320514
MOTOR PROTECTOR, ROTARY- 9-14 AMPS	GV2P16	14320516
MOTOR PROTECTOR, TOGGLE-.63-1 AMPS	GV2ME05	14320205
MOTOR PROTECTOR, TOGGLE- 1.6-2.5 AMPS	GV2ME07	14320207
MOTOR PROTECTOR, TOGGLE- 1-1.6 AMPS	GV2ME06	14320206
MOTOR PROTECTOR, TOGGLE- 13-18 AMPS	GV2ME20	14320220
MOTOR PROTECTOR, TOGGLE- 17-23 AMPS	GV2ME21	14320221
MOTOR PROTECTOR, TOGGLE- 2.5-4 AMPS	GV2ME08	14320208
MOTOR PROTECTOR, TOGGLE- 20-25 AMPS	GV2ME22	14320222
MOTOR PROTECTOR, TOGGLE- 24-32 AMPS	GV2ME32	14320232
MOTOR PROTECTOR, TOGGLE- 25-40 AMPS	GV2ME40	14320340
MOTOR PROTECTOR, TOGGLE- 45-63 AMPS	GV2ME63	14320363

Description	Mfg. Model Number	Part Number
MOTOR PROTECTOR, TOGGLE- 4-6.3 AMPS	GV2ME10	14320210
MOTOR PROTECTOR, TOGGLE- 6-10 AMPS	GV2ME14	14320214
MOTOR PROTECTOR, TOGGLE- 9-14 AMPS	GV2ME16	14320216
OVERLOAD-.4-.63 AMPS	LRD04	14320801
OVERLOAD-.63-1 AMPS	LRD05	14320802
OVERLOAD- 1.6-2.5 AMPS	LRD07	14320804
OVERLOAD- 1-1.6 AMPS	LRD06	14320803
OVERLOAD- 110-140 AMPS	LRD4369	14320820
OVERLOAD- 12-18 AMPS	LRD21	14320810
OVERLOAD- 16-24 AMPS	LRD22	14320811
OVERLOAD- 2.5-4 AMPS	LRD08	14320805
OVERLOAD- 23-32 AMPS	LRD32	14320812
OVERLOAD- 30-40 AMPS	LRD3355	14320813
OVERLOAD- 3-13 AMPS	LRD16	14320809
OVERLOAD- 37-50 AMPS	LRD3357	14320814
OVERLOAD- 4-6 AMPS	LRD10	14320806
OVERLOAD- 48-65 AMPS	LRD3359	14320815
OVERLOAD- 5.5-8 AMPS	LRD12	14320807
OVERLOAD- 55-70 AMPS	LRD3361	14320816
OVERLOAD- 63-80 AMPS	LRD3363	14320817
OVERLOAD- 7-10 AMPS	LRD14	14320808
OVERLOAD- 80-104 AMPS	LRD4365	14320818
OVERLOAD- 95-120 AMPS	LRD4367	14320819

27.7 Replacement Filters



Description	Mfg. Model Number	Part Number
FILTER, 30% POLYESTER 16 x 25	N/A	14074200
FILTER, 30% POLYESTER 20 x 20	N/A	14074201
FILTER, 30% POLYESTER 20 x 25	N/A	14074202
FILTER, DISPOSABLE 2 x 16 x 20	N/A	82400050
FILTER, DISPOSABLE 2 x 16 x 25	N/A	82400060
FILTER, DISPOSABLE 2 x 20 x 20	N/A	82400070
FILTER, DISPOSABLE 2 x 20 x 25	N/A	82400080
FILTER, PERMANENT 2 x 16 x 20	N/A	82400140
FILTER, PERMANENT 2 x 16 x 25	N/A	82400150
FILTER, PERMANENT 2 x 20 x 20	N/A	82400160
FILTER, PERMANENT 2 x 20 x 25	N/A	82400170
FILTER, 30% PLEATED 2 x 16 x 25	N/A	82402830
FILTER, 30% PLEATED 2 x 16 x 20	N/A	82402850
FILTER, 30% PLEATED 2 x 20 x 25	N/A	82402860
FILTER, 30% PLEATED 2 x 20 x 20	N/A	82402870

27.8 Miscellaneous Replacement Parts

Description	Mfg. Model Number	Part Number
BLOWER AIRFLOW PROVING SWITCH - 0.17>12"	8024206082	83100006
BLOWER AIRFLOW PROVING BYPASS TIMER	RE11RMMU	804-001-02
BULB HOLDER	#31126D	81100310
CLOGGED FILTER SWITCH 0.17>12"	8024206082	83100006
DOOR GASKET- 1/2 X 3/4	NES41B	10949903
DOOR HANDLE- LATCH, COMPRESSION, SLOTTED	E3-109-075	14303506
DOOR HANDLE- VENTLOC (CHROME COLORED)	333	10500401
FAN/LIMIT REAR COVER	05099-0653	14279410
FAN/LIMIT WITH 10' SENSOR	DFL	14279401
FAN/LIMIT WITH 20' SENSOR	DFL	14279402
FUSE	FNM5	10361700
FUSE	FNQ 2	10461500
GAS PRESSURE SWITCH-COMBO GAS PRESSURE SW MTG BRACKET	808000302	14297002
GAS PRESSURE SWITCH-COMBO HIGH/LOW PRESSURE	HLGP-A	14297001
LIGHT-TOP HAT/AMBER/120V/NEON (NEDCO)	1050C3	14297311
LIGHT-TOP HAT/GREEN/120V/NEON (NEDCO)	1050C5	14297313

Description	Mfg. Model Number	Part Number
LIGHT-TOP HAT/RED/120V/NEON (NEDCO)	1050C1	14297310
LIGHT-TOP HAT/WHITE/120V/NEON (NEDCO)	1050C4	14297312
LOW LIMIT SWITCH WITH 10FT SENSOR	8563100141	14016902
LOW LIMIT SWITCH WITH 20FT SENSOR	8563100151	14016903
NULL PRESSURE SWITCH.01-.20	1640-0	11050300
OUTDOOR THERMOSTAT	T675A1508	83200002
OUTDOOR THERMOSTAT- CNTRL TEMP SPDT 25-225 DEG	A1911F-12	83200001
RELAY-4PDT 120V IDEC	RY4S	14132300
RELAY-DPDT 120V IDEC	RY2S	14163900
RESISTOR 124 OHM	-	14072706
RESISTOR 140 OHM	-	14072701
RESISTOR 150 OHM	-	14072705
RESISTOR 237 OHM	-	14072702
RESISTOR 35.7 OHM	-	14072708
RESISTOR 47.5 OHM	-	14072707
RESISTOR 66.5 OHM	-	14072703
RESISTOR 71.4 OHM	-	14072704
STATIC PRESSURE SENSOR	A306	14096501
SWITCH-N/O CONTACT BLOCK SINGLE-POSITION	E22B2	14132601
SWITCH-N/O-N/C CONTACT BLOCK SINGLE-POSITION	E22B20	14142900
SWITCH-SUMMER/OFF/WINTER OPERATOR	E22VG1	14135703
TOGGLE SWITCH-3PDT ON/ON	7702K2	14217303
TOGGLE SWITCH-DPDT-ON/OFF	7561K6	14217304
TOGGLE SWITCH-DPDT-ON/OFF	7565K7	14217301
TOGGLE SWITCH-DPDT-ON/OFF/ON	7563K6	14217302
TOGGLE SWITCH-SPDT-ON/OFF	7501K15	14217300
TRANSFORMER- ISOLATION 40 VA 120-24V	AT72D1089	83000020
TRANSFORMER- MICRON CONTROL W/FUSE BLOCK 200 THRU 480 V	B500-0107-5H	10115301

SECTION 28: TROUBLESHOOTING

⚠ DANGER	
	
<p style="text-align: center;">Electrical Shock Hazard</p> <p>Disconnect electric before service.</p> <p>More than one disconnect switch may be required to disconnect electric from equipment.</p> <p>Equipment must be properly grounded.</p>	<p style="text-align: center;">Severe Injury Hazard</p> <p>Do not enter equipment while in operation.</p> <p>Equipment may start automatically.</p> <p>Do not operate with door open.</p> <p>Installation, operation and service must be done by a trained technician only.</p>
<p>Failure to follow these instructions can result in death, electrical shock or injury.</p>	

⚠ WARNING				
				
<p style="text-align: center;">Explosion Hazard</p> <p>Turn off gas/oil supply to equipment before service.</p>	<p style="text-align: center;">Fire Hazard</p> <p>Keep all flammable objects, liquids and vapors the minimum required clearances to combustibles away from equipment.</p> <p>Some objects will catch fire or explode when placed close to equipment.</p>	<p style="text-align: center;">Falling Hazard</p> <p>Use proper safety equipment and practices to avoid falling.</p> <p>Do not use any part of equipment as support.</p>	<p style="text-align: center;">Burn Hazard</p> <p>Allow equipment to cool before service.</p> <p>Internal components of equipment may still be hot after operation.</p>	<p style="text-align: center;">Cut/Pinch Hazard</p> <p>Wear protective gear during installation, operation and service.</p> <p>Edges are sharp.</p>
<p>Failure to follow these instructions can result in death, injury or property damage.</p>				

The following is divided into two basic categories - fan problems and burner problems. In some cases, they interrelate. In order to use this effectively, you should familiarize yourself with both categories.

28.1 Initial Checks

When encountering any abnormal operation or fault conditions of the equipment, all troubleshooting should start with the following initial checks. If a problem is discovered in these initial checks, it must be corrected before moving on in the trouble shooting.

1. Compare voltage and phase of supply power on site with rating plate information.
2. Review wiring between remote panel and control panel. Do the electrical connections match the supplied wiring diagram?
3. Compare gas type and supply pressure on site with rating plate information.
4. Check for proper blower rotation - on air handler and any exhaust blowers.
 - Blowers powered with a three phase motor can be reversed by swapping any two incoming power legs to the motor starter. For blowers powered by a single phase motor, refer to the motor rating plate for reversing instructions.

28.2 Supply Fan

PROBLEM	POSSIBLE CAUSE	SOLUTION
Blower motor does not run	Damper limit switch not closed or inoperative.	Repair or replace switch.
	Motor thermal over-loads tripped.	For tripped condition-reset.
	Fuses blown or missing.	Replace.
	External power source lacking.	Have incoming power lines checked.
	Motor inoperative.	Repair or replace.
Blower motor runs, but fans do not supply enough make-up air	Belts broken or loose.	Readjust or replace.
	Intake filters dirty.	Replace or clean.
	Obstruction in intake.	Check dampers for proper operation. Clear all intake passages of obstructions.
	Fan wheel loose on shaft.	Reposition and tighten.
	Access doors and panels not closed.	Close.
	Excessive discharge resistance from: Dirty filters in discharge. External dampers.	Clean filters and/or readjust dampers.
Excessive fan noise	Fan bearing	Replace.
	Fan sheave loose on shaft.	Tighten.
	Belts not adjusted.	Readjust.
	Fan wheel loose on shaft.	Reposition and retighten.
	Fan wheel rubbing.	Loosen setscrews. Reposition wheel and tighten.
	Fan wheel dirty.	Clean.
	Loose duct.	Tighten or reinforce.
	Foreign article in fan or duct.	Remove.

28.3 Burner

PROBLEM	POSSIBLE CAUSE	SOLUTION
Burner Fails to Start	Defective On/Off or fuel transfer switch.	Replace.
	Control circuit has an open control contact.	Check limits, proof of closure switch and others as applicable.
	Bad fuse or switch open on in-coming power source.	Correct as required.
	Motor overloads tripped.	Reset and correct cause for trip out.
	Flame safeguard control safety switch tripped out.	Reset and determine cause for apparent flame failure.
	Loose connections or faulty wiring.	Tighten all terminal screws and consult wiring diagram furnished with the air handler.
	Frozen oil pump shaft preventing blower motor operation.	Replace oil pump.
	Flame safeguard control starting circuit blocked due to flame relay being energized.	Possible defective scanner - replace. Possible defective amplifier -replace. Scanner actually sighting flame due to leaking fuel valve-correct unwanted flame cause. Defective flame safeguard control - replace.
	Defective blower motor.	Repair or replace.
Occasional Lockouts for No Apparent Reason	Gas pilot ignition failure.	Refer to pilot adjustment section and readjust to make certain that ignition is instant and that flame signal readings are stable and above minimum values. Use a manometer or 0 to 10 wc (24.9 mbar) gas pressure gauge on pilot test tee to make certain that pressure is as recommended.
	Check for proper settings on direct spark oil ignition electrodes.	Make certain that gap is not too wide and that light-off oil pressure is as recommended.
	Gas pilot ignition and direct spark oil ignition.	Verify that there are no cracks in the porcelain and that transformer end and electrode end plug in connections are tight.
	Loose or broken wires.	Check all wire nut connections and tighten all terminal screw connections in panel and elsewhere as appropriate.
	With flame safeguard controls that incorporate the air flow switch in the non-recycling circuit, ensure that when main flame lights, the air flow switch is not so critically set as to allow occasional momentary opening of the air switch contacts.	

Burner (continued)

PROBLEM	POSSIBLE CAUSE	SOLUTION
Occasional Lockouts for No Apparent Reason	Occasional low voltage supply.	Have local utility correct.
	Occasional low gas supply pressure.	Have local utility correct.
	Air leak in oil suction line or check valve not holding.	Correct as required.

28.4 Gas Operation

PROBLEM	POSSIBLE CAUSE	SOLUTION
Burner Motor Runs, but Pilot Does Not Light	Gas supply to burner shut off.	Make sure all manual gas supply valves are open. Automatic high pressure.
	Pilot solenoid valve not opening.	Listen and feel for valve actuation. Solenoid valve not being powered--check electrical circuitry. Replace coil or entire valve if coil is burned out.
	Defective gas pilot regulator.	Replace.
	Gas pressure too high or too low at pilot orifice.	Refer to gas pilot adjustments for correct settings. Readjust as required.
	Defective ignition transformer.	Replace.
	Incorrect ignition electrode settings.	Refer to gas pilot adjustments for correct settings.
	Defective flame safeguard control or plug in purge timing card.	Replace as required.
	Air flow switch not making circuit.	Check out electrically and correct pressure adjustment on switch If required.
	Defective air flow switch.	Replace.
Burner Motor Runs and Pilot Lights, but Main Gas Flame is Not Established.	Air switch negative pressure sensing tube out of position.	Reposition as necessary.
	Main shut off or test cock closed.	Check to make certain fully open.
	Pilot flame signal reading too low to pull in flame safeguard relay.	Refer to gas pilot settings section and readjust as required.
	Defective automatic main or auxiliary gas shut off valves.	Check electrical circuitry to valves. Replace valves or correct circuitry as required.
	Defective flame safeguard control or plug in amplifier.	Check and replace as required.
	Butterfly valve set incorrectly on modulating burner.	Readjust as required.
	Main gas pressure regulator atmospheric vent line obstructed.	Correct.
Defective main gas pressure regulator	Replace.	
Misadjusted main gas pressure regulator	Readjust to meet required operational values.	

Gas Operation (continued)

PROBLEM	POSSIBLE CAUSE	SOLUTION
Carbon Monoxide Readings on Gas Firing	Flame impingement on cold start-up of heat exchanger caused by excessive firing rate.	Reduce firing rate to correct input volume.
	Incorrect gas/air ratios.	Readjust burner to correct CO ₂ /O ₂ levels, reducing CO formation to appropriate level.
Gas High Fire Input Cannot Be Achieved	Gas company pressure regulator or meter operating incorrectly, not allowing required gas pressure at gas train inlet.	Have gas company correct.
	Gas cock upstream of train inlet not fully open.	Check and correct.
	Gas line obstructed.	Check and correct.
	Gas train main and/or leak test cocks not fully open.	Check and correct.
	Automatic gas valve not opening fully due to defective operation.	Replace gas valve.
	On modulating burner, butterfly valve not fully opened.	Readjust.
	Defective main gas pressure regulator.	Replace.
	Main gas pressure regulator vent line obstructed.	Check and correct.
Normally open vent valve (if supplied) not closing when automatic gas valves open.	Check to see if valve is fully closed when automatic valves are open. Replace vent valve, if not closing fully.	

28.5 Oil Operation

PROBLEM	POSSIBLE CAUSE	SOLUTION
Burner Motor Runs, but Direct Spark Ignited Oil Flame is Not Established	Defective oil nozzle.	Remove and clean or replace.
	Low oil pressure.	Check with gauge for correct light-off pressure.
	Defective oil pump.	Replace.
	Defective oil solenoid valve.	Replace.
	Oil pump coupling loose or defective.	Replace or tighten as required.
	Low oil pressure switch (if supplied) defective.	Adjust or replace switch.
	Ignition transformer defective.	Replace.
	Ignition electrode set incorrectly.	Remove electrodes and reset.
	Ignition electrodes cracked and grounding out spark.	Replace electrodes.
	Ignition lead wire defective and grounding spark out.	Replace.
	Ignition plug-in connections at transformer or electrodes loose.	Tighten.
	Air flow switch (if provided) not making.	Reset pressure or replace.
	Defective flame safeguard control or plug in purge timer card.	Replace.
	Air dampers held in high fire position due to mechanical binding of linkage.	Readjust linkage.
Loose wiring connections.	Check and tighten all connections.	

Oil Operation (continued)

PROBLEM	POSSIBLE CAUSE	SOLUTION
Oil Flame Ignites, but then Flame Safeguard Control Locks Out on Safety.	Flame scanner lens dirty.	Remove and clean.
	Scanner sight tube blocked or dirty.	Check and clean.
	Flame scanner defective.	Replace.
	Defective oil nozzle causing unstable flame and scanning problems.	Replace oil nozzle.
	Fuel/air ratios incorrect, resulting in unstable or smoky flame causing scanner flame sighting problem.	Readjust ratios for clean stable flame.
Oil Flame Extremely Smoky at Light Off or in Low Fire Position.	Defective or incorrect size oil nozzle.	Replace.
	Fuel/air ratio incorrect.	Readjust.
	Normally closed oil solenoid valve in oil nozzle return line not opening.	Check electrical circuitry and replace valve if defective.
	On two-step pump - Normally open pump mounted solenoid valve malfunctioning.	Replace valve or pump.
Light off Oil Flame Is Established and Proven, but Burner Will Not Attempt to go to the High Fire Position	Low/High/Low or Modulating burner high fire temperature or pressure control could be defective or not set to call for high fire.	Readjust or replace control.
	Loose wires.	Verify wiring and tighten all connections.
	Flame safeguard control or high fire panel switching relay (if supplied) defective.	Verify and correct as required.
	High fire 3 way solenoid valve defective.	Replace.
	Hydraulic oil cylinder defective.	Replace.
	On two-step pump - Normally open solenoid valve defective (not closing).	Replace pump or valve.
	Linkage mechanically binding.	Readjust linkage.
Low Oil Flame Is Established and Proven, but Flame Out Occurs in Transition from Low Fire to High Fire	On Low/High/Off or Low/High/Low system - Normally closed oil solenoid valve in nozzle return line not closing (or leaking).	Check valve operation and replace if necessary.
	On two-step oil pump - Normally open solenoid valve defective (not closing).	Replace valve or pump.
	Defective oil nozzle.	Replace.
	High fire oil pressure too low.	Readjust.
	Air dampers set too far open at low fire, which causes flame to blow out in starting to high fire.	Readjust dampers.
	Oil pump coupling loose or defective.	Tighten or replace.
	Defective oil pump.	Replace.
	Linkage mechanically binding.	Readjust.
	Make certain the #72 orifice into the normally closed side of the 3 way valve has not been removed.	
On modulating systems - fuel/air ratios set incorrectly, causing flame to blow out when going to high fire.	Readjust linkage.	

Oil Operation (continued)

PROBLEM	POSSIBLE CAUSE	SOLUTION
White Smoke Formation on Oil Firing	Oil/Air ratios incorrect due to excess air, or oil flow is too low.	Readjust for proper fuel input, CO ₂ and smoke reading.
Gray or Black Smoke Formation on Oil Firing	Defective or dirty oil nozzle.	Replace or clean nozzle.
	Incorrect oil/air ratios.	Readjust burner to correct CO ₂ and smoke levels.
	Oil pressure too low resulting in poor atomization.	Readjust.
	Impingement of raw oil spray on the blast tube choke ring or oil nozzle air diffuser.	Make certain that the diffuser is seated firmly against the oil nozzle adapter shoulder. Position the oil gun assembly fore or aft in the blast tube to assist in elimination of oil spray on the blast tube choke ring.
Oil High Fire Input Rate Cannot Be Achieved	Nozzle defective or mesh filter dirty.	Replace or clean mesh.
	Oil supply pressure to nozzle too low.	Readjust.
	Oil pump defective.	Replace.
	On Low/High/Off and Low/High/Low systems - Normally closed oil solenoid valve in nozzle return line not closing (or leaking).	Check valve operation and replace if necessary.
	On two-step pump - Normally open pump mounted oil solenoid valve defective (not closing).	Replace valve or pump.
	Oil pump coupling loose (slipping) or defective.	Replace.
	Linkage mechanically binding.	Readjust.
	On modulating burner, oil nozzle return line metering valve set incorrectly.	Readjust to attain required nozzle bypass pressure.
	Oil suction line is partially blocked.	Clean.
	Blocked or dirty suction line oil filter.	Replace or clean.
	Manual valves in suction line not fully open.	Check and correct.
	Suction line check valve or foot valve operating incorrectly.	Check and correct.
	Vent system on oil tank blocked creating vacuum on tank, with high vacuum and lowered oil flow to burner.	Check and correct.

28.6 Burner Control Module

BLINK CODE	SYSTEM FAILURE	RECOMMENDED TROUBLESHOOTING
Code 1-1 *Low AC Line Voltage*	Low AC Line detected.	1. Check the relay module and display module connections.
Code 1-2*AC Quality Problem*	Excessive noise or device running on slow, fast, or AC line dropout detected.	2. Reset and sequence the relay module. 3. Check the 7800 power supply and make sure that frequency and voltage meet specifications. 4. Check the backup power supply, as appropriate.
Code 2-1*Unexpected Flame Signal*	Flame sensed when no flame is expected during STANDBY or PURGE.	1. Check that flame is not present in the combustion chamber; correct any errors. 2. Make sure that the flame amplifier and flame detector are compatible. 3. Check the wiring and correct any errors. 4. Remove the flame amplifier and inspect its connections. Reseat the amplifier. 5. Reset and sequence the relay module. 6. If the code reappears, replace the flame amplifier and/or the flame detector. 7. If the fault persists, replace the relay module.
Code 2-2*Flame Signal Absent*	No-flame time present at the end of the Pilot Flame Establishing Period; lost during the Main Flame Establishing Period or during RUN.	1. Measure the flame signal. If one exists, verify that it meets specifications. 2. Make sure that the flame amplifier and flame detector are compatible. 3. Inspect the main fuel valve(s) and valve connection(s). 4. Verify that the fuel pressure is sufficient to supply fuel to the combustion chamber. Inspect the connections to the fuel pressure switches. Make sure they are functioning properly. 5. Inspect the airflow switch and make sure that it is functioning properly. 6. Check the flame detector sighting position; reset and recycle. Measure the flame signal strength. Verify that it meets specifications. If not, refer to the flame detector and/or flame amplifier checkout procedures in the installation instructions. 7. Replace the flame amplifier and/or the flame detector, if necessary. 8. If the fault persists, replace the relay module.
Code 2-3*Flame Signal Over range*	Flame signal value is too high to be valid.	1. Make sure the flame detector and flame amplifier are compatible. 2. Remove the flame amplifier and inspect its connections. Reseat the flame amplifier. 3. Reset and sequence the relay module. 4. Check the flame detector sighting position; reset and recycle. Measure flame strength. Verify that it meets specifications. If not, refer to the flame detector and/or flame amplifier checkout procedures in the installation instructions. 5. If the code reappears, replace the flame amplifier and/or the flame detector. 6. If the fault persists, replace the relay module.

Burner Control Module (continued)

BLINK CODE	SYSTEM FAILURE	RECOMMENDED TROUBLESHOOTING
Code 3-1*Running/Interlock Switch Problem*	Running or Lockout Interlock fault during Pre-Purge.	<ol style="list-style-type: none"> 1. Check wiring; correct any errors. 2. Inspect the fan; make sure there is no air intake blockage and that it is supply-ing air. 3. Make sure the lockout interlock switches are functioning properly and the contacts are free from contaminants. 4. Reset and sequence the relay module to Pre-Purge (place the TEST/RUN Switch in the TEST position, if available). Measure the voltage between terminal 7 and G (ground); line voltage should be present. Switch TEST/RUN back to RUN. 5. If steps 1 through 4 are correct and the fault persists, replace the relay module.
Code 3-2*Running/Interlock On During Standby*	Lockout Interlock powered at improper point in sequence or On in Standby.	<ol style="list-style-type: none"> 1. Check wiring to make sure that the lockout interlock are connected properly between terminals 6 and 7. Correct any errors. 2. Reset and sequence the relay module. 3. If the fault persists, measure the voltage between terminal 6 and G (ground), then between terminal 7 and G. If there is line voltage at terminal 6 when the controller is off, the controller switch may be bad or is jumpered. 4. If steps 1 through 3 are correct and there is line voltage at terminal 7 when the controller is closed and the fault persists, check for a welded or jumpered running interlock or airflow switch. Correct any errors. 5. If steps 1 through 4 are correct and the fault persists, replace the relay module.
Code 3-3*VPS in Improper State*	VPS (Valve Proving Switch) in wrong state during VPS Test.	<ol style="list-style-type: none"> 1. Check wiring, making sure upstream valve is connected to terminal 9 and downstream valve is connected to terminal 17. 2. Conduct valve seat leakage test using a manometer. 3. Reset and sequence the relay module; if fault repeats, test VPS (connected to terminal 16) is functioning properly; replace if necessary. 4. Reset and sequence the relay module. 5. If fault persists, replace the relay module.
Code 4-1*Purge Card Problem*	No purge card or the purge card timing has changed from the original configuration.	<ol style="list-style-type: none"> 1. Make sure the purge card is seated properly. 2. Inspect the purge card and the connector on the relay module for any damage or contaminants. 3. Reset and sequence the relay module. 4. If the fault code reappears, replace the purge card. 5. Reset and sequence the relay module.6.If the fault code persists, replace the relay module.
Code 4-2*Wiring Problem/Internal Fault*	Pilot (ignition) valve terminal, main valve, ignition or Main Valve 2 was on when it should be off.	<ol style="list-style-type: none"> 1. Remove system power and turn off fuel supply. 2. Check wiring; correct any errors. 3. Inspect pilot fuel valve(s), both places, and connections. 4. Reset and sequence the relay module. 5. If the fault persists, replace the relay module.

Burner Control Module (continued)



BLINK CODE	SYSTEM FAILURE	RECOMMENDED TROUBLESHOOTING
Code 4-3*Flame Amplifier Problem*	Flame not sensed, or sensed when it should be on or off.	<ol style="list-style-type: none"> 1. Check wiring; correct any errors. 2. Make sure the flame amplifier and flame detector are compatible. 3. Remove the flame amplifier and inspect the connections. Reseat the amplifier. 4. Reset and sequence the relay module. 5. If the code reappears, replace the flame amplifier and/or the flame detector. 6. If the fault persists, replace the relay module.
Code 4-4*Configuration Jumper Problem*	The configuration jumpers differ from the sample taken at startup.	<ol style="list-style-type: none"> 1. Inspect the jumper connections. Make sure the clipped jumpers were completely removed. 2. Reset and sequence the relay module. 3. If the fault persists, replace the relay module.
Code 5-1*Pre-Ignition Interlock*	Pre-Ignition Interlock fault.	<ol style="list-style-type: none"> 1. Check wiring and correct any errors. 2. Check pre-ignition interlock switches to assure proper functioning. 3. Check fuel valve operation. 4. Reset and sequence the relay module; monitor the Pre-Ignition Interlock status. 5. If the fault persists, replace the relay module.
Code 5-2*High Fire Sw. or Low Fire Sw.*	Either High Fire Switch or Low Fire Switch failure.	<ol style="list-style-type: none"> 1. Check wiring and correct any errors. 2. Reset and sequence the relay module. 3. Use manual motor potentiometer to drive the motor open and closed. Verify at motor switch that the end switches are operating properly. Use RUN/TEST switch if manual potentiometer is not available. 4. Reset and sequence the relay module. 5. If the fault persists, replace the relay module.
Code 5-3*Man-Open Sw.; Start Sw. or Control On*	Man-Open Switch, Start Switch or Control On in the wrong operational state.	<ol style="list-style-type: none"> 1. Check wiring and correct any errors. 2. Make sure that the manual open valve switch, start switch and control are operating properly. 3. Stat Switch held "On" too long. 4. Reset and sequence the relay module. 5. Reset and sequence the relay module. If the fault persists, replace the relay module (RM7838A1014; RM7838B1013 or RM7838C1004 only).
Code 6-1*Internal Faults*	Relay Module self-test failure.	<ol style="list-style-type: none"> 1. Reset and sequence the relay module. 2. If fault reappears, remove power from the device, reapply power, then reset and sequence the relay module. 3. If the fault persists, replace the relay module.
Code 6-2*Internal Faults*	Relay Module Self-Test failure.	<ol style="list-style-type: none"> 1. Reset and sequence the relay module. 2. If fault reappears, remove power from the device, reapply power, then reset and sequence the relay module. 3. If fault does not repeat on the next cycle, check for electrical noise being copied into the relay module through the external loads or possibly an electrical grounding issue. 4. If the fault persists, replace the relay module.



Burner Control Module (continued)

BLINK CODE	SYSTEM FAILURE	RECOMMENDED TROUBLESHOOTING
Code 6-3*Device Specific*	Fault with special OEM input circuits.	<ol style="list-style-type: none"> 1. Check wiring and operation of special OEM inputs. 2. Reset and sequence the relay module. 3. If fault reappears, remove power from the device, reapply power, then reset and sequence the relay module. 4. If the fault does not repeat on the next cycle, check for electrical noise being copied into the relay module through the external loads or possibly an electrical grounding issue. 5. If the fault persists, replace the relay module.
Code 6-4*Accessory Fault*	VPS setup.	<ol style="list-style-type: none"> 1. Make sure Relay Module VP is programmed. 2. T6 and T17 powered at the same time—correct wiring. 3. Reset control if fault persists. Replace relay module.
Code 7-7*Unused*	Unused at this time.	-

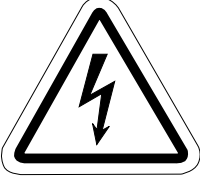
Additional trouble shooting information can be found in the Flame Safeguard Control bulletin supplied with the air handler.

28.7 ROBERTS GORDON® IDF Start-Up Procedures

⚠ DANGER	
	
<p style="text-align: center;">Electrical Shock Hazard</p> <p>Disconnect electric before service.</p> <p>More than one disconnect switch may be required to disconnect electric from equipment.</p> <p>Equipment must be properly grounded.</p>	<p style="text-align: center;">Severe Injury Hazard</p> <p>Do not enter equipment while in operation.</p> <p>Equipment may start automatically.</p> <p>Do not operate with door open.</p> <p>Installation, operation and service must be done by a trained technician only.</p>
Failure to follow these instructions can result in death, electrical shock or injury.	

⚠ WARNING		
		
<p style="text-align: center;">Explosion Hazard</p> <p>Leak test all components of equipment gas piping before operation.</p> <p>Gas can leak if piping is not installed properly.</p> <p>Do not high pressure test gas piping with equipment connected.</p>	<p style="text-align: center;">Falling Hazard</p> <p>Use proper safety equipment and practices to avoid falling.</p> <p>Do not use any part of equipment as support.</p>	<p style="text-align: center;">Burn Hazard</p> <p>Allow equipment to cool before service.</p> <p>Internal components of equipment may still be hot after operation.</p>
Failure to follow these instructions can result in death, injury or property damage.		

Model:	<input type="text"/>	Invoice No. of Burner:	<input type="text"/>	Serial No.:	<input type="text"/>
Installation Name:	<input type="text"/>			Start Up Date:	<input type="text"/>
Start Up Contractors Name:	<input type="text"/>			Phone No.:	<input type="text"/>
Name of Technician Doing Start Up:	<input type="text"/>			Burner Rotation Correct?	<input type="text"/>
Type of Gas:	Natural: <input type="text"/>	L.P.:	<input type="text"/>	Fuel Grade No.:	<input type="text"/>

Gas Fired

Gas Pressure at Train Inlet Burner in off position <input type="text"/> " W.C.	Flame Signal Readings Pilot <input type="text"/> Low Fire <input type="text"/> High Fire <input type="text"/>	Net Stack Temperature Low Fire <input type="text"/> High Fire <input type="text"/>
Gas Pressure at Train Inlet Low Fire <input type="text"/> High Fire <input type="text"/>	CO₂ or O₂ (Specify) Low Fire <input type="text"/> High Fire <input type="text"/>	Combustion Efficiency Low Fire % <input type="text"/> High Fire % <input type="text"/>
Gas Pressure at Firing Head Low Fire <input type="text"/> High Fire <input type="text"/>	CO Low Fire <input type="text"/> High Fire <input type="text"/>	
Gas Pressure at Pilot Test Tee Low Fire <input type="text"/>	Input Rate BTU/HR Low Fire <input type="text"/> High Fire <input type="text"/>	
Flame Signal Readings Volts: <input type="text"/> Ph: <input type="text"/> Hz.: <input type="text"/> Control Circuit Volts <input type="text"/> Blower Motor Amps at High Fire <input type="text"/>	Tank Pressure High Fire <input type="text"/>	

Oil Fired

High Fire Vacuum Reading at Oil Pump Inlet <input type="text"/> " H.G.	Power Supply Volts: <input type="text"/> Ph: <input type="text"/> Hz.: <input type="text"/> Control Circuit Volts <input type="text"/> Blower Motor Amps at High Fire <input type="text"/> Remote Oil Pump Amps at High Fire <input type="text"/>
Gas Pressure at Pilot Train Inlet (If Applicable) <input type="text"/>	
Gas Pressure at Pilot Train Tee (If Applicable) <input type="text"/>	
Oil Nozzle Supply Pressure Low Fire <input type="text"/> High Fire <input type="text"/>	Flame Signal Readings Pilot (if Applicable) <input type="text"/> Low Fire <input type="text"/> High Fire <input type="text"/>
Oil Nozzle Bypass Pressure Low Fire <input type="text"/> High Fire <input type="text"/>	GPH Firing Rate Low Fire <input type="text"/> High Fire <input type="text"/>
CO₂ or O₂ (Specify) Low Fire <input type="text"/> High Fire <input type="text"/>	Net Stack Temperature Low Fire <input type="text"/> High Fire <input type="text"/>
Bachrach Scale Smoke Number Low Fire <input type="text"/> High Fire <input type="text"/>	Combustion Efficiency Low Fire <input type="text"/> % High Fire <input type="text"/> %

Control Settings

General

Fan Limit (Fan switch set to 110, HYS Pot set at 15)
 Burner Air Flow Operating
 Full Mod. High Fire Purge
 Full Mod. Low Fire Start
 Full Mod Cycling On/Low Fire Start
 Freeze Stat: 3 Min.-35
 Outdoor Stat: 65
 High Temp Limit [set to 200° F (93° C)]

Gas

Low Gas Pressure Switch
 High Gas Pressure Switch

Oil

Low Oil Pressure Switch
 High Oil Pressure Switch

Check all door seals and latches. Confirm the latch is adjusted for proper tension

Check control lights for proper operation (if applicable)

Check temperature control location

Check temperature sensor mounting

Check incoming power supply (line voltage) before turning on unit disconnect.
 (NOTE: for 3 phase, voltage should be measured from line to line)

Leg1-2 Leg1-3 Leg2-3 /60/Phase

Record nameplate voltage from serial tag.
 Voltage Phase 60Hz

(NOTE: This must match incoming power supply. If not, contact the Weather-Rite Representative of Weather-Rite directly)

Record serial and electrical drawing number from the serial tag on the door of the air make-up unit

Serial No. Electrical Drawing No.

(NOTE: Refer to this number when contacting Weather-Rite on all service questions relating to the air make-up unit)

Record full load amps (f.l.a.) for the voltage matching the service voltage on all motors and set overloads. Set overloads at nameplate

Supply Motor f.l.a. Overloads set at amp
 Exhaust Motor f.l.a. Overloads set at amp

Check the belt tension on supply blower. Adjust if necessary
 (NOTE: Belt should not move more than 1/2 inch)

Locate pilot gas line and open pipe plug to bleed off main gas line.

After bleeding, connect pressure gauge to the gas line where the plug was removed and measure incoming gas pressure.
 Record Pressure " W.C.

(NOTE: If pressure is more than 28" of water column (1 LB), a pressure regulator is required. Consult service manual for maximum

Insure pilot and main gas valves are off

START-UP "NO HEAT"

Place all disconnects in "ON" position and test for 120 V on transformer secondary to ground before turning the selector switch to "SUMMER" mode. The unit will start up in the "no heat" mode.

Check for the correct rotation of supply blower. (Reverse if necessary.)

Check for the correct rotation of exhaust fan motor(s). (Reverse if necessary)(If applicable)

Measure and record amp draws

SUPPLY BLOWER MOTOR

Leg 1 Leg 2 Leg 3

Measure and record RPM of blower:

Note ambient air temperature, with the unit running in the "no heat" mode. Ambient air temperature: _____ deg. F

Check to see that only the pilot shut off valve is open an burner valve is off. Reset the optional low gas pressure switch if the unit is equipped with it and jumper out the optional high gas pressure switch if the unit is equipped with it.

Start the burner. Move the selector switch to "Winter" or "Heat".

After pilot lights, check the flame signal. Read and record the D.C. voltage. Do a visual inspection of the pilot flame and make any adjustments if needed

D.C. Volts

Open main shut off valve; visually inspect the burner to make sure it is not over firing

Adjust the temperature rise to match the serial tag temperature rise

Record the inlet gas pressure while the unit is on high fire w.c.

(NOTE: The minimum gas pressure must be at least the value listed on the unit serial tag. If this requirement is not met, the unit will not

The following items should be completed during the final walk through with the customer***Personnel Training Review***

It is important that everyone concerned with the operation and maintenance of the equipment be trained in the safety procedures contained in the operation.

Operation of the temperature control? (Including "heat" minimum temp. rise?)
If no, explain:

Location and operation of safety disconnect switch? (use lockout/tag out procedures)
If no, explain:

Proper maintenance and replacement of filters?
If no, explain:

Location and operation of safety devices and location of reset buttons?
If no, explain:

SECTION 29: THE ROBERTS GORDON® COMBAT® IDF-SERIES WARRANTY

ROBERTS-GORDON LLC WILL PAY FOR:

Within 24 months from date of purchase by buyer or 27 months from date of shipment by Roberts-Gordon LLC (whichever occurs first), replacement parts will be provided free of charge for any part of the product which fails due to a manufacturing or material defect.

Roberts-Gordon LLC will require the part in question to be returned to the factory. Roberts-Gordon LLC will, at its sole discretion, repair or replace after determining the nature of the defect and disposition of part in question.

ROBERTS GORDON® Replacement Parts are warranted for the later of 12 months from date of shipment from Roberts-Gordon LLC or the remaining ROBERTS GORDON® Combat® IDF-Series warranty.

ROBERTS-GORDON LLC WILL NOT PAY FOR:

Service trips, service calls and labor charges.

Shipment of replacement parts.

Claims where the total price of the goods have not been paid.

Damage due to:

- Improper installation, operation or maintenance.
- Misuse, abuse, neglect, or modification of the ROBERTS GORDON® Combat® IDF-Series in any way.
- Use of the ROBERTS GORDON® Combat® IDF-Series for other than its intended purpose.
- Incorrect gas or electrical supply, accident, fire, floods, acts of God, war, terrorism, or other casualty.
- Improper service, use of replacement parts or accessories not specified by Roberts-Gordon LLC.
- Failure to install or maintain the ROBERTS GORDON® Combat® IDF-Series as directed in the Installation, Operation and Service Manual.
- Relocation of the ROBERTS GORDON® Combat® IDF-Series after initial installation.
- Use of the ROBERTS GORDON® Combat® IDF-Series in a corrosive atmosphere containing contaminants.
- Use of the ROBERTS GORDON® Combat® IDF-Series in the vicinity of a combustible or explosive material.
- Any defect in the ROBERTS GORDON® Combat® IDF-Series arising from a drawing, design, or specification supplied by or on behalf of the consumer.
- Damage incurred during shipment. Claim must be filed with carrier.

WARRANTY IS VOID IF:

The ROBERTS GORDON® Combat® IDF-Series is not installed by an contractor qualified in the installation and service of gas fired heating equipment.

You cannot prove original purchase date and required annual maintenance history.

The data plate and/or serial number are removed, defaced, modified or altered in any way.

The ownership of the ROBERTS GORDON® Combat® IDF-Series is moved or transferred. This warranty is non-transferable.

Roberts-Gordon LLC is not permitted to inspect the damaged equipment and/or component parts.

READ YOUR INSTALLATION, OPERATION AND SERVICE MANUAL.

If you have questions about your equipment, contact your installing professional. Should you need Replacement Parts or have additional questions, call or write:

Roberts Gordon

1250 William Street

P.O. Box 44

Buffalo, New York 14240-0044

Telephone: +1.716.852.4400

Fax: +1.716.852.0854

Toll Free: 800.828.7450

www.robertsgordon.com

www.rg-inc.com

Roberts-Gordon LLC's liability, and your exclusive remedy, under this warranty or any implied warranty (including the implied warranties of merchantability and fitness for a particular purpose) is limited to providing replacement parts during the term of this warranty. Some jurisdictions do not allow limitations on how long an implied warranty lasts, so this limitation may not apply to you. There are no rights, warranties or conditions, expressed or implied, statutory or otherwise, other than those contained in this warranty.

Roberts-Gordon LLC shall in no event be responsible for incidental or consequential damages or incur liability for damages in excess of the amount paid by you for the ROBERTS GORDON® Combat® IDF-Series. Some jurisdictions do not allow the exclusion or limitation of incidental or consequential damages, so this limitation or exclusion may not apply to you. This warranty gives you specific legal rights, and you may also have other rights which vary from jurisdiction to jurisdiction.

Roberts-Gordon LLC shall not be responsible for failure to perform under the terms of this warranty if caused by circumstances out of its control, including but not limited to war, fire, flood, strike, government or court orders, acts of God, terrorism, unavailability of supplies, parts or power. No person is authorized to assume for Roberts-Gordon LLC any other warranty, obligation or liability.

LIMITATIONS ON AUTHORITY OF REPRESENTATIVES:

No representative of Roberts-Gordon LLC, other than an Executive Officer, has authority to change or extend these provisions. Changes or extensions shall be binding only if confirmed in writing by Roberts-Gordon LLC's duly authorized Executive Officer.

