

FOR YOUR SAFETY

If you smell gas:

1. Open windows.
2. **DO NOT** try to light any appliance.
3. **DO NOT** use electrical switches.
4. **DO NOT** use any telephone in your building.
5. Extinguish any open flame.
6. Leave the building.
7. Immediately call your local gas supplier after leaving the building. Follow the gas supplier's instructions.
8. If you cannot reach your gas supplier, call the Fire Department.

⚠ WARNING



Fire Hazard

Keep all flammable objects, liquids and vapors the minimum required clearances to combustibles away from heater.

Some objects will catch fire or explode when placed close to heater.

Failure to follow these instructions can result in death, injury or property damage.

GORDONRAY®
ROBERTS GORDON®

Model DF

Gas-Fired, Low Intensity Two Stage Unitary Heater

Installation, Operation & Service Manual

DF-80
DF-100
DF-125
DF-150
DF-175
DF-200

⚠ WARNING

Improper installation, adjustment, alteration, service or maintenance can result in death, injury or property damage. Read the Installation, Operation and Service Manual thoroughly before installing or servicing this equipment.

Installation must be done by a contractor qualified in the installation and service of gas-fired heating equipment or your gas supplier.

Installer

Please take the time to read and understand these instructions prior to any installation. Installer must give a copy of this manual to the owner.

Owner

Keep this manual in a safe place in order to provide your service technician with necessary information.



Roberts-Gordon LLC
1250 William Street
Buffalo, New York 14240-0044

www.robertsgordon.com

TABLE OF CONTENTS

| | | | |
|--|-----------|--|-----------|
| SECTION 1: Heater Safety | 1 | 10.4 Ladder Diagram | 54 |
| 1.1 Manpower Requirements | 1 | 10.5 Electrical Connection to the Burner | 54 |
| 1.2 Safety Labels and Their Placement..... | 1 | SECTION 11: Operation and Maintenance | 55 |
| 1.3 California Proposition 65 | 1 | 11.1 Sequence of Operation | 55 |
| SECTION 2: Installer Responsibility | 4 | 11.2 High/Low Firing Operation..... | 55 |
| 2.1 Wall Tag | 4 | 11.3 Sequence of Operation | 55 |
| 2.2 Corrosive Chemicals..... | 4 | 11.4 To Shut Off Heater | 56 |
| 2.3 National Standards and Applicable Codes..... | 4 | 11.5 To Start Heater | 56 |
| SECTION 3: Clearances to Combustibles | 5 | 11.6 Pre-Season Maintenance and Annual Inspection..... | 56 |
| 3.1 Required Clearances to Combustibles..... | 5 | 11.7 Maintenance Checklist | 56 |
| SECTION 4: National Standards and Applicable Codes | 10 | SECTION 12: Troubleshooting | 58 |
| 4.1 Gas Codes..... | 10 | 12.1 Troubleshooting Flow Chart | 59 |
| 4.2 Aircraft Hangars | 10 | 12.2 Manifold Gas Pressure Setting | 61 |
| 4.3 Public Garages | 10 | SECTION 13: Replacement Parts | 62 |
| 4.4 Electrical | 10 | SECTION 14: General Specifications | 65 |
| 4.5 Venting..... | 10 | 14.1 Material Specifications..... | 65 |
| 4.6 High Altitude | 10 | 14.2 Heater Specifications..... | 65 |
| SECTION 5: Major Components | 11 | 14.3 Suspension Specifications..... | 65 |
| 5.1 Standard Parts List | 13 | 14.4 Controls Specifications | 65 |
| SECTION 6: Heater Installation | 15 | SECTION 15: The ROBERTS GORDON® GORDONRAY® DF | |
| SECTION 7: Optional Heater Accessories | 30 | Warranty | 68 |
| 7.1 U-Tube Configuration..... | 30 | | |
| 7.2 Elbow Package Configuration..... | 33 | | |
| 7.3 Reflector Side Extension | 36 | | |
| 7.4 Lower Clearance Shield Installation | 37 | | |
| 7.5 Two-Foot Decorative Grille Installation | 37 | | |
| 7.6 Protective Grille Installation | 39 | | |
| SECTION 8: Venting | 40 | | |
| 8.1 Venting..... | 40 | | |
| 8.2 Unvented Operation..... | 41 | | |
| 8.3 Horizontal Venting (Category III)..... | 41 | | |
| 8.4 Vertical Venting (Category III) | 41 | | |
| 8.5 Unvented Operation Tube Termination..... | 42 | | |
| 8.6 Length Requirements | 42 | | |
| 8.7 Vent Material Recommendations | 42 | | |
| 8.8 Horizontal Venting (Category III) 4" (10 cm) Pipe | 43 | | |
| 8.9 Vertical Venting (Category III) 4" (10 cm) Pipe..... | 43 | | |
| 8.10 Common Side Wall Horizontal Venting (Category III)..... | 44 | | |
| 8.11 Common Vertical Venting (Category III) | 45 | | |
| 8.12 Outside Combustion Air Supply | 46 | | |
| SECTION 9: Gas Piping | 49 | | |
| SECTION 10: Wiring | 51 | | |
| 10.1 Dual Stage Low Voltage Thermostat Wiring..... | 51 | | |
| 10.2 Multiple Burners For Connection To One Thermostat..... | 52 | | |
| 10.3 Internal Wiring..... | 53 | | |

© 2023 Roberts-Gordon LLC

All rights reserved. No part of this work covered by the copyrights herein may be reproduced or copied in any form or by any means - graphic, electronic, or mechanical, including photocopying, recording, taping or information storage and retrieval systems - without the written permission of Roberts-Gordon LLC.

SECTION 1: HEATER SAFETY



Your Safety is Important to Us!
This symbol is used throughout the manual to notify you of possible fire, electrical or burn hazards. Please pay special attention when reading and following the warnings in these

sections.

Installation, service and annual inspection of heater must be done by a contractor qualified in the installation and service of gas-fired heating equipment.

Read this manual carefully before installation, operation or service of this equipment.

This heater is designed for heating nonresidential indoor spaces. Do not install in residential spaces. This heater is not certified to meet the requirements of NFPA30A-2012 Section 7.6.6. (maximum tube temperature of 750 °F (399 °C)). Do not install this heater in facilities where compressed natural gas (CNG) or liquid natural gas (LNG) are present. These instructions, the layout drawing, local codes and ordinances, and applicable standards that apply to gas piping, electrical wiring, venting, etc. must be thoroughly understood before proceeding with the installation.

Protective gear is to be worn during installation, operation and service in accordance to the Occupational Safety and Hazard Administration (OSHA). Gear must be in accordance to NFPA 70E, latest revision when working with electrical components. Thin sheet metal parts have sharp edges. To prevent injury, the use of work gloves is recommended. The use of gloves will also prevent the transfer of body oils from the hands to the surface of the reflector.

Before installation, check that local distribution conditions, nature of gas and pressure, and adjustment of the appliance are compatible.

This heater must be applied and operated under the general concepts of reasonable use and installed using best building practices.

This appliance is not intended for use by persons (including children) with reduced physical, sensory or mental capabilities, or lack of experience and knowledge, unless they have been given supervision or instruction concerning use of the appliance by a person responsible for their safety. Children should be supervised to ensure that they do not play with the appliance.

For additional copies of the Installation, Operation and Service Manual, please contact Roberts-Gordon LLC.

1.1 Manpower Requirements

To prevent personal injury and damage to the heater, two persons will be required for installation.

1.2 Safety Labels and Their Placement

Product safety signs or labels should be replaced by the product user when they are no longer legible. Please contact Roberts-Gordon LLC or your ROBERTS GORDON® independent distributor to obtain replacement signs or labels. See *Page 2, Figure 1 through Page 3, Figure 2*.

1.3 California Proposition 65

In accordance with California Proposition 65 requirements, a warning label must be placed in a highly visible location on the outside of the equipment (i.e., near equipment's serial plate). See label placement drawing on *Page 3, Figure 2* for label location. Avoid placing label on areas with extreme heat, cold, corrosive chemicals or other elements. To order additional labels, please contact Roberts-Gordon LLC or your ROBERTS GORDON® independent distributor.

FIGURE 1: Top and Bottom Panel Label Placement

Top Panel

Gas Connection Label

Vent Length Label

Logo Label

Burner Status Light Label

Bottom Panel

WARNING
Tighten and install gas hose fittings to connect gas supply according to standards tables.
Gas hose can crack when twisted.
Gas hose must be installed according to standards tables.
Use only air (1/2" NPT) fittings connected at 90° or 180° (permitted).
Connectors supplied with header for U.S. models (not with Canadian models).
Failure to follow these instructions can result in death, injury or property damage.

ATTENTION
Risque d'incendie
Serrez et installez les raccords de condition de gaz pour relier le source de gaz selon les normes.
Le ligne de gaz de câble peut se fissurer une fois tordue.
Le ligne de gaz de câble doit être installé selon les normes.
Utilisez seulement les connecteurs de 90° ou 180° (si permis).
Les connecteurs sont fournis avec le chauffage pour les modèles américains (Pas avec les modèles canadiens).
Le non-respect de ces consignes peut causer la mort, les blessures ou le dommage matériel.

Correct Position / Position Exacte
The gas hose must be installed in a straight line. Do not use any elbows or fittings. The gas hose must be installed in a straight line. Do not use any elbows or fittings. The gas hose must be installed in a straight line. Do not use any elbows or fittings.

Incorrect Position / Position Incorrecte
The gas hose must not be installed in a U-shape or with any fittings. The gas hose must not be installed in a U-shape or with any fittings. The gas hose must not be installed in a U-shape or with any fittings.

VENT LENGTH REQUIREMENT
EXIGENCES CONCERNANT L'ÉVACUATION GÉNÉRALE DES GAZ

WARNING
Carbon Monoxide Hazard
Venting must be installed with sufficient length according to the installation manual.
Failure to follow these instructions can result in death or injury.

ATTENTION
Risque d'exposé de carbone
Le drainage à vent évacuation des gaz doit être installé avec une longueur adéquate selon le manuel d'installation.
Le non-respect de ces consignes peut causer la mort, les blessures ou le dommage matériel.

Total Vent Length/Longueur totale de l'évacuation des gaz: 45' (13.7m) (45' to 132')
Total de la longueur d'évacuation des gaz: 45' (13.7m) (45' to 132')
Total Condensate Vent Length/Longueur totale de l'évacuation des gaz condensés: 45' (13.7m) (45' to 132')
Longueur totale de l'évacuation des gaz condensés: 45' (13.7m) (45' to 132')

SEE INSTALLATION MANUAL FOR FURTHER DETAILS.
VOIR LE MANUEL D'INSTALLATION POUR PLUS DE RENSEIGNEMENTS.

Printed in the U.S.A./Imprimé aux États-Unis P/N 91032500 Rev. 0

FIGURE 2: Side and Back Panel Label Placement

Model No. [] **Gas** []

Serial No. []

Normal Input Rating []

Min. Input Rating []

Gas Pressure at Inlet []

Gas Inlet Pressure []

Outdoor Installation []

Electrical Rating []

Reflector May Be Installed at []

Equipped for Reflector []

Standard []

For Broiler Use []

ROBERTS GORDON Buffalo, New York, USA

Low-Intensity Infrared Heater/Reflector à faible intensité

Low-Intensity Infrared Heater/Reflector à faible intensité

CSA N.C. #189175

CSA N.C. #189175

CSA N.C. #189175

WARNING

This equipment, its related accessories and by-products of operation, contain chemicals known to the State of California to cause cancer and birth defects or other reproductive harm.

ADVERTENCIA

Este equipo, sus accesorios y los productos derivados de su operación contienen productos químicos que el Estado de California considera causantes de cáncer y defectos de nacimiento u otros daños reproductivos.

Printed in U.S.A. Impreso en E.U.A. P/N: 91070016 Dtg

Proposition 65 Label

WARNING

Improper installation, adjustment, alteration, service or maintenance can result in death, injury or property damage. Read the installation, Operating and Maintenance Instructions thoroughly before installing or servicing this equipment.

ATTENTION

Les erreurs d'installation de réglage de modification, intervention ou d'entretien peuvent provoquer des décès, blessures et même la mort. Lire attentivement les notices d'installation, d'opération et d'entretien avant d'installer ou d'entretenir cet équipement.

PELIGRO

Instalación, ajuste, alteración o mantenimiento incorrecto de este equipo puede ocasionar muerte, lesiones, o daños a la propiedad. Lea bien las instrucciones de instalación, operación y servicio antes de instalar o componer este equipo.

TO SHUT OFF HEATER:

1. Set thermostat to lowest setting.
2. Turn OFF electric power to heater.
3. Turn OFF manual gas valve in the heater supply line.

TO START HEATER:

1. Turn gas valve and electric power OFF and wait five minutes for unburned gases to vent from heater.
2. Turn ON main gas valve.
3. Turn ON electric power.
4. Set thermostat above ambient temperature, burner should light automatically.

FOUR ÉTAPES POUR ARRÊTER LE CHAUFFEUR:

1. Régler le thermostat sur la position la plus basse.
2. Couper l'alimentation électrique au chauffe-pour.
3. Couper le robinet manuel principal du gaz.

POUR METTRE EN MARCHÉ LE CHAUFFEUR:

1. Fermer le robinet de gaz après que le robinet de courant électrique et attendre cinq minutes pour que les gaz non brûlés s'échappent de la chambre de chauffe.
2. Ouvrir le robinet manuel principal de gaz.
3. Allumer l'alimentation électrique de la chambre.
4. Régler le thermostat au-dessus de la température ambiante et le brûleur devrait s'allumer automatiquement. Régler le thermostat à la température désirée.

Printed in U.S.A. Impreso en E.U.A. P/N: 91029602 E

Wiring Label

Control Door (Inside)

Lighting Instruction Plate Label

Control Side Panel

| Description | Part Number |
|----------------------------------|-------------|
| Rating Plate Label | 91010401 |
| Lighting Instruction Plate Label | 91029602 |
| Wiring Label | 91032801 |
| Clearances to Combustibles Label | 91010461 |
| Proposition 65 Label | 91070016 |
| Thermostat Connection Label | 91033000 |

WARNING

Fire Hazard

Keep all flammable objects, liquids and vapors the minimum required clearances to combustibles away from heater. Some objects will catch fire or explode when placed close to heater. Failure to follow these instructions can result in death, injury or property damage.

ATTENTION

Risque d'incendie

Tout objet inflammable, liquide et vapeurs inflammables à la distance minimale de sécurité requise du radiateur peuvent s'enflammer ou exploser. Le non-respect de ces consignes peut causer mort, blessures ou dommages matériels.

Clearances to Combustibles / Distancias de Seguridad por Report aux Combustibles

NOTES: 1. Back numerals are in inches. Change numerals into a centimeters. 2. All dimensions are from the surface of all fittings, couplings and elbows. 3. Clearances B, C and D can be reduced by 50% after 25' (7.6 m) of tubing - dimensions from where the burner on the burner tube connects. 4. Protective and gas pipe clearances are the same as reflector, when installed under the last 10' (3m). "Clearances for Two-Fire" Rates

NOTES: 1. Tous les chiffres sont en pouces. Les chiffres changent sont en centimètres. 2. Toutes les dimensions sont mesurées de la surface de tous les tubes, couplings et coudes. 3. Les distances de dégagement B, C et D peuvent être réduites de 50% pour tout enlèvement par plus de 25' ou plus en nombre de la connexion entre le brûleur et le tube du brûleur. 4. Les dégagements des grilles de protection et de dico sont les mêmes que ceux du réflecteur de 45°.

Clearances for Two-Fire Rates

| Input (Btu/h x 1000) | A | B | C | D | A | B | C | D | A | B | C | D |
|----------------------|----|----|----|----|----|----|----|----|----|----|----|----|
| 40 | 12 | 17 | 11 | 14 | 12 | 17 | 11 | 14 | 12 | 17 | 11 | 14 |
| 50 | 12 | 17 | 11 | 14 | 12 | 17 | 11 | 14 | 12 | 17 | 11 | 14 |
| 60 | 12 | 17 | 11 | 14 | 12 | 17 | 11 | 14 | 12 | 17 | 11 | 14 |
| 70 | 12 | 17 | 11 | 14 | 12 | 17 | 11 | 14 | 12 | 17 | 11 | 14 |
| 80 | 12 | 17 | 11 | 14 | 12 | 17 | 11 | 14 | 12 | 17 | 11 | 14 |
| 90 | 12 | 17 | 11 | 14 | 12 | 17 | 11 | 14 | 12 | 17 | 11 | 14 |
| 100 | 12 | 17 | 11 | 14 | 12 | 17 | 11 | 14 | 12 | 17 | 11 | 14 |
| 110 | 12 | 17 | 11 | 14 | 12 | 17 | 11 | 14 | 12 | 17 | 11 | 14 |
| 120 | 12 | 17 | 11 | 14 | 12 | 17 | 11 | 14 | 12 | 17 | 11 | 14 |
| 130 | 12 | 17 | 11 | 14 | 12 | 17 | 11 | 14 | 12 | 17 | 11 | 14 |
| 140 | 12 | 17 | 11 | 14 | 12 | 17 | 11 | 14 | 12 | 17 | 11 | 14 |
| 150 | 12 | 17 | 11 | 14 | 12 | 17 | 11 | 14 | 12 | 17 | 11 | 14 |
| 160 | 12 | 17 | 11 | 14 | 12 | 17 | 11 | 14 | 12 | 17 | 11 | 14 |
| 170 | 12 | 17 | 11 | 14 | 12 | 17 | 11 | 14 | 12 | 17 | 11 | 14 |
| 180 | 12 | 17 | 11 | 14 | 12 | 17 | 11 | 14 | 12 | 17 | 11 | 14 |
| 190 | 12 | 17 | 11 | 14 | 12 | 17 | 11 | 14 | 12 | 17 | 11 | 14 |
| 200 | 12 | 17 | 11 | 14 | 12 | 17 | 11 | 14 | 12 | 17 | 11 | 14 |
| 210 | 12 | 17 | 11 | 14 | 12 | 17 | 11 | 14 | 12 | 17 | 11 | 14 |
| 220 | 12 | 17 | 11 | 14 | 12 | 17 | 11 | 14 | 12 | 17 | 11 | 14 |
| 230 | 12 | 17 | 11 | 14 | 12 | 17 | 11 | 14 | 12 | 17 | 11 | 14 |
| 240 | 12 | 17 | 11 | 14 | 12 | 17 | 11 | 14 | 12 | 17 | 11 | 14 |
| 250 | 12 | 17 | 11 | 14 | 12 | 17 | 11 | 14 | 12 | 17 | 11 | 14 |
| 260 | 12 | 17 | 11 | 14 | 12 | 17 | 11 | 14 | 12 | 17 | 11 | 14 |
| 270 | 12 | 17 | 11 | 14 | 12 | 17 | 11 | 14 | 12 | 17 | 11 | 14 |
| 280 | 12 | 17 | 11 | 14 | 12 | 17 | 11 | 14 | 12 | 17 | 11 | 14 |
| 290 | 12 | 17 | 11 | 14 | 12 | 17 | 11 | 14 | 12 | 17 | 11 | 14 |
| 300 | 12 | 17 | 11 | 14 | 12 | 17 | 11 | 14 | 12 | 17 | 11 | 14 |

91010461 Dtg

Clearances to Combustibles Label

SECTION 2: INSTALLER RESPONSIBILITY

The installer is responsible for the following:

- To install the heater, as well as the gas and electrical supplies, in accordance with applicable specifications and codes. Roberts-Gordon LLC recommends the installer contact a local Building Inspector or Fire Marshal for guidance.
- To use the information given in a layout drawing and in the manual together with the cited codes and regulations to perform the installation.
- To install the heater in accordance with the clearances to combustibles.
- To furnish all needed materials not furnished as standard equipment.
- To plan location of supports.
- To provide access on all sides for burner servicing and removal.
- To provide the owner with a copy of this Installation, Operation and Service Manual.
- To never use heater as a support for a ladder or other access equipment and never hang or suspend anything from heater.
- To ensure there is adequate air circulation around the heater and to supply air for combustion, ventilation and distribution in accordance with local codes.
- To safely and adequately install heater using materials with a minimal working load of 75 lbs (33 kg).
- To ensure the heater is placed in an approved application.

2.1 Wall Tag

A laminated wall tag is available for the heater as a permanent reminder of the safety instructions and the importance of the required clearances to combustibles. Please contact Roberts-Gordon LLC or your ROBERTS GORDON® independent distributor to obtain the wall tag. Affix the tag by peeling off the backing of the adhesive strips on the rear surface and position the tag on a wall near the heater (e.g. thermostat or ROBERTS GORDON® Controller).

A copy of the wall tag (P/N 91037912) is illustrated on the back cover. For an immediate solution, you may affix this copy on the wall near the heater.

Know your model number and installed configuration. Model number and installed configuration are found on the burner and in the Installation, Operation and Service Manual. *and Page 6, Figure 3 through Page 8, Figure 11.* Write the proper clearance dimensions in

permanent ink according to your model number and configuration in the open spaces on the tag.

2.2 Corrosive Chemicals

| |
|---|
|  |
| <p>Product Damage Hazard</p> <p>Do not use heater in area containing corrosive chemicals.</p> <p>Refer to appropriate Material Safety Data Sheets (MSDS).</p> <p>Failure to follow these instructions can result in product damage.</p> |

Roberts-Gordon LLC cannot be responsible for ensuring that all appropriate safety measures are undertaken prior to installation; this is entirely the responsibility of the installer. It is essential that the contractor, the sub-contractor, or the owner identifies the presence of combustible materials, corrosive chemicals or halogenated hydrocarbons* anywhere in the premises.

** **Halogenated Hydrocarbons** are a family of chemical compounds characterized by the presence of halogen elements (fluorine, chlorine, bromine, etc.). These compounds are frequently used in refrigerants, cleaning agents, solvents, etc. If these compounds enter the air supply of the burner, the life span of the heater components will be greatly reduced. An outside air supply must be provided to the burners whenever the presence of these compounds is suspected. Warranty will be invalid if the heater is exposed to halogenated hydrocarbons.*

2.3 National Standards and Applicable Codes

All appliances must be installed in accordance with the latest revision of the applicable standards and national codes. This refers also to the electric, gas and venting installation. Note: Additional standards for installations in public garages, aircraft hangars, etc. may be applicable.

SECTION 3: CLEARANCES TO COMBUSTIBLES

3.1 Required Clearances to Combustibles

Clearances are the required distances that combustible objects must be away from the heater to prevent serious fire hazards. Combustibles are materials that may catch on fire and include common items such as wood, paper, rubber, fabric, etc.

Maintain clearances to combustibles at all times for safety.

Clearances for all heater models are located on the burner of the heater and on Page 6, Figure 3 through Page 8, Figure 11 in this manual. Check the clearances on each burner for the model heater being installed to make sure the product is suitable for your application and the clearances are maintained. Read and follow the safety guidelines below:

- Keep gasoline or other combustible materials including flammable objects, liquids, dust or vapors away from this heater or any other appliance.
- The stated clearances to combustibles represents a surface temperature of 90 °F (32 °C) above room temperature. Building materials with a low heat tolerance (such as plastics, vinyl siding, canvas, tri-ply, etc) may be subject to degradation at lower temperatures. It is the installer's responsibility to assure that adjacent materials are protected from degradation.
- Maintain clearances from heat sensitive equipment and workstations.
- Maintain clearances from vehicles parked below the heater.
- Maintain clearances from swinging and overhead doors, overhead cranes, vehicle lifts, partitions, storage racks, hoists, building construction, etc.
- In locations used for the storage of combustible materials, signs must be posted to specify the maximum permissible stacking height to maintain required clearances from the heater to the combustibles. Signs must be posted adjacent to the heater thermostat. In the absence of a thermostat, signs must be posted in a conspicuous location.
- Consult local Fire Marshal, Fire Insurance Carrier or other authorities for approval of proposed installation when there is a possibility of exposure to combustible airborne materials or vapors.
- Hang heater in accordance to the minimum suspension requirements on Page 17, Figure 15.

! WARNING



Fire Hazard

Keep all flammable objects, liquids and vapors the minimum required clearances to combustibles away from heater.

Some objects will catch fire or explode when placed close to heater.

Failure to follow these instructions can result in death, injury or property damage.

- If the radiant tubes must pass through the building structure, be sure that adequate sleeving and fire stop is installed to prevent scorching and/or fire hazard.

NOTE: 1. All dimensions are from the surfaces of all tubes, couplings and elbows.
 2. Clearances B, C and D can be reduced by 50% after 25' (7.5 m) of tubing downstream from where the burner and burner tube connect.

FIGURE 3: Level Reflector

|  | Model | (inches) | | | | (centimeters) | | | |
|---|--------|----------|----|----|----|---------------|-----|-----|-----|
| | | A | B | C | D | A | B | C | D |
| | DF-80 | 6 | 38 | 65 | 38 | 16 | 97 | 166 | 97 |
| | DF-100 | 6 | 40 | 70 | 40 | 16 | 102 | 178 | 102 |
| | DF-125 | 6 | 46 | 76 | 46 | 16 | 117 | 194 | 117 |
| | DF-150 | 6 | 50 | 79 | 50 | 16 | 127 | 201 | 127 |
| | DF-175 | 8 | 52 | 82 | 52 | 21 | 133 | 209 | 133 |
| | DF-200 | 8 | 52 | 96 | 52 | 21 | 133 | 244 | 133 |

FIGURE 4: One Side Reflector

|  | Model | (inches) | | | | (centimeters) | | | |
|--|--------|----------|----|-----|----|---------------|----|-----|-----|
| | | A | B | C | D | A | B | C | D |
| | DF-80 | 6 | 9 | 69 | 54 | 16 | 23 | 176 | 138 |
| | DF-100 | 6 | 9 | 76 | 59 | 16 | 23 | 194 | 150 |
| | DF-125 | 6 | 9 | 82 | 65 | 16 | 23 | 209 | 166 |
| | DF-150 | 6 | 9 | 85 | 69 | 16 | 23 | 216 | 176 |
| | DF-175 | 8 | 9 | 88 | 73 | 21 | 23 | 224 | 186 |
| | DF-200 | 8 | 18 | 102 | 73 | 21 | 46 | 260 | 186 |

FIGURE 5: Two Side Reflectors

|  | Model | (inches) | | | | (centimeters) | | | |
|---|--------|----------|----|-----|----|---------------|-----|-----|-----|
| | | A | B | C | D | A | B | C | D |
| | DF-80 | 6 | 25 | 71 | 25 | 16 | 64 | 181 | 64 |
| | DF-100 | 6 | 27 | 77 | 27 | 16 | 69 | 196 | 69 |
| | DF-125 | 6 | 32 | 83 | 32 | 16 | 82 | 211 | 82 |
| | DF-150 | 6 | 35 | 87 | 35 | 16 | 89 | 221 | 89 |
| | DF-175 | 8 | 40 | 91 | 40 | 21 | 102 | 232 | 102 |
| | DF-200 | 8 | 40 | 102 | 40 | 21 | 102 | 260 | 102 |

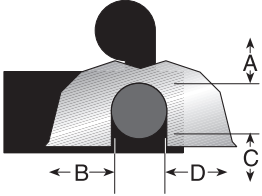
- NOTE:** 1. All dimensions are from the surfaces of all tubes, couplings and elbows.
 2. Clearances B, C and D can be reduced by 50% after 25' (7.5 m) of tubing downstream from where the burner and burner tube connect.

FIGURE 6: 45° Tilt Reflector

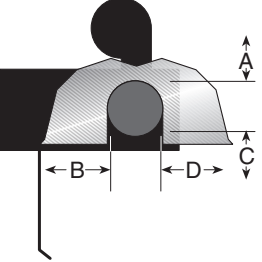
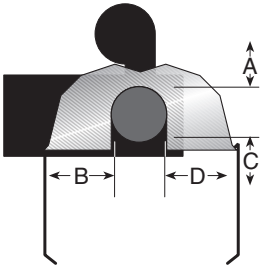
|  | Model | (inches) | | | | (centimeters) | | | |
|---|--------|----------|----|----|----|---------------|----|-----|-----|
| | | A | B | C | D | A | B | C | D |
| | DF-80 | 8 | 8 | 65 | 60 | 21 | 21 | 166 | 153 |
| | DF-100 | 10 | 8 | 73 | 64 | 26 | 21 | 186 | 163 |
| | DF-125 | 10 | 8 | 77 | 69 | 26 | 21 | 196 | 176 |
| | DF-150 | 12 | 8 | 83 | 74 | 31 | 21 | 211 | 188 |
| | DF-175 | 12 | 8 | 85 | 79 | 31 | 21 | 216 | 201 |
| | DF-200 | 12 | 10 | 85 | 79 | 31 | 26 | 216 | 201 |

FIGURE 7: U-Tube, Standard Reflector

|  | Model | (inches) | | | | (centimeters) | | | |
|--|--------|----------|----|-----|----|---------------|-----|-----|-----|
| | | A | B | C | D | A | B | C | D |
| | DF-80 | 6 | 38 | 68 | 37 | 16 | 97 | 173 | 94 |
| | DF-100 | 6 | 40 | 75 | 39 | 16 | 102 | 191 | 100 |
| | DF-125 | 6 | 46 | 78 | 43 | 16 | 117 | 199 | 110 |
| | DF-150 | 6 | 50 | 83 | 47 | 16 | 127 | 211 | 120 |
| | DF-175 | 8 | 54 | 87 | 51 | 21 | 138 | 221 | 130 |
| | DF-200 | 8 | 54 | 102 | 51 | 21 | 138 | 260 | 130 |

FIGURE 8: U-Tube, 45°

|  | Model | (inches) | | | | (centimeters) | | | |
|---|--------|----------|---|----|----|---------------|----|-----|-----|
| | | A | B | C | D | A | B | C | D |
| | DF-80 | 8 | 8 | 65 | 46 | 21 | 21 | 166 | 117 |
| | DF-100 | 8 | 8 | 73 | 52 | 21 | 21 | 186 | 133 |
| | DF-125 | 8 | 8 | 77 | 61 | 21 | 21 | 196 | 155 |
| | DF-150 | 8 | 8 | 83 | 66 | 21 | 21 | 211 | 168 |
| | DF-175 | 8 | 8 | 85 | 70 | 21 | 21 | 216 | 178 |
| | DF-200 | 8 | 8 | 85 | 70 | 21 | 21 | 216 | 178 |

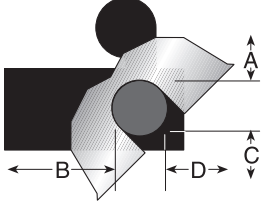
NOTE: 1. All dimensions are from the surfaces of all tubes, couplings and elbows.
 2. Clearances B, C and D can be reduced by 50% after 25' (7.5 m) of tubing downstream from where the burner and burner tube connect.

FIGURE 9: U-Tube, Opposite 45° Reflector

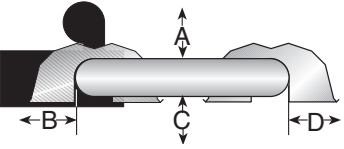
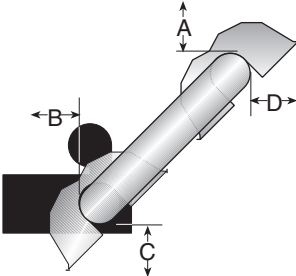
|  | Model | (inches) | | | | (centimeters) | | | |
|---|------------|----------|----|----|----|---------------|-----|-----|----|
| | | A | B | C | D | A | B | C | D |
| | DF-80 | 8 | 60 | 65 | 22 | 21 | 153 | 166 | 56 |
| | DF-100 | 10 | 64 | 73 | 22 | 26 | 163 | 186 | 56 |
| | DF-115/125 | 10 | 70 | 77 | 22 | 26 | 178 | 196 | 56 |
| | DF-140/150 | 12 | 74 | 83 | 22 | 31 | 188 | 211 | 56 |
| | DF-175 | 12 | 76 | 85 | 22 | 31 | 194 | 216 | 56 |
| | DF-200 | 12 | 76 | 85 | 22 | 31 | 194 | 216 | 56 |

FIGURE 10: 2-Foot Deco Grille and Protective Grille

|  | Model | (inches) | | | | (centimeters) | | | |
|--|--------|----------|----|----|----|---------------|-----|-----|-----|
| | | A | B | C | D | A | B | C | D |
| | DF-80 | 6 | 38 | 65 | 38 | 16 | 97 | 166 | 97 |
| | DF-100 | 6 | 40 | 70 | 40 | 16 | 102 | 178 | 102 |
| | DF-125 | 6 | 46 | 76 | 46 | 16 | 117 | 194 | 117 |
| | DF-150 | 6 | 50 | 79 | 50 | 16 | 127 | 201 | 127 |
| | DF-175 | 8 | 52 | 82 | 52 | 21 | 133 | 209 | 133 |
| | DF-200 | 8 | 52 | 96 | 52 | 21 | 133 | 244 | 133 |

FIGURE 11: Lower Clearance Shield*

|  | Model | (inches) | | | | (centimeters) | | | |
|---|--------|----------------|----|----|----|----------------|-----|-----|-----|
| | | A | B | C | D | A | B | C | D |
| | DF-80 | 6 | 40 | 38 | 40 | 16 | 102 | 97 | 102 |
| | DF-100 | 6 | 50 | 44 | 50 | 16 | 127 | 112 | 127 |
| | DF-125 | 6 | 54 | 48 | 54 | 16 | 138 | 122 | 138 |
| | DF-150 | 6 | 55 | 50 | 55 | 16 | 140 | 127 | 140 |
| | DF-175 | - UNAPPROVED - | | | | - UNAPPROVED - | | | |
| | DF-200 | - UNAPPROVED - | | | | - UNAPPROVED - | | | |

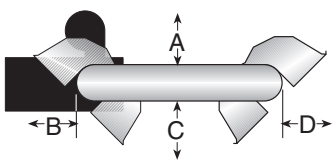
*When installed in the first 10' (3 m).

- NOTE:** 1. All dimensions are from the surfaces of all tubes, couplings and elbows.
 2. Clearances B, C and D can be reduced by 50% after 25' (7.5 m) of tubing downstream from where the burner and burner tube connect.

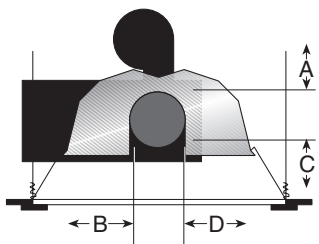
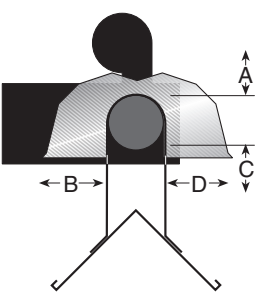
FIGURE 12: Venting

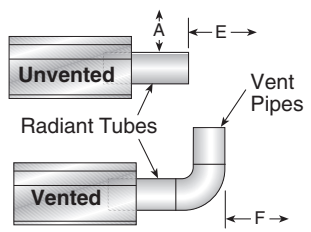
|  | Model | (inches) | | | (centimeters) | | |
|---|------------|----------|----|----|---------------|----|----|
| | | A | E | F | A | E | F |
| | DF-80 | 20 | 24 | 18 | 51 | 61 | 46 |
| | DF-100 | 20 | 24 | 18 | 51 | 61 | 46 |
| | DF-125 | 20 | 24 | 18 | 51 | 61 | 46 |
| | DF-150 | 20 | 30 | 18 | 51 | 77 | 46 |
| | DF-175/200 | 20 | 30 | 18 | 51 | 77 | 46 |

SECTION 4: NATIONAL STANDARDS AND APPLICABLE CODES

4.1 Gas Codes

Type of gas appearing on the nameplate must be the type of gas used. Installation must comply with national and local codes and requirements of the local gas company.

United States: Refer to National Fuel Gas Code NFPA 54/ANSI Z223.1 - latest revision.

Canada: Refer to Natural Gas and Propane Installation Code CSA B149.1 - latest revision.

4.2 Aircraft Hangars

Installation in aircraft hangars must be in accordance with the following codes:

United States: Refer to Standard for Aircraft Hangars, NFPA 409 - latest revision.

Canada: Refer to Natural Gas and Propane Installation Code CSA B149.1 - latest revision.

In aircraft storage and servicing areas, heaters shall be installed at least 10' (3 m) above the upper surface of wings or of engine enclosures of the highest aircraft which may be housed in the hangar. The measurement shall be made from the wing or engine enclosure (whichever is higher from the floor) to the bottom of the heater.

- In shops, offices and other sections of aircraft hangars communicating with aircraft storage or servicing areas, heaters shall be installed not less than 8' (2.4 m) above the floor.
- Suspended or elevated heaters shall be so located in all spaces of aircraft hangars that they shall not be subject to injury by aircraft, cranes, movable scaffolding or other objects. Provisions shall be made to assure accessibility to suspended heaters for recurrent maintenance purposes.

4.3 Public Garages

Installation in garages must be in accordance with the following codes:

United States: Refer to Standard for Parking Structures NFPA 88A - latest revision or the Code for Motor Fuel Dispensing Facilities and Repair Garages, NFPA 30A - latest revision.

Canada: Refer to Natural Gas and Propane Installation Code CSA B149.1 - latest revision.

- Heaters must not be installed less than 8' (2.4 m) above the floor. Minimum clearances to combustibles must be maintained from vehicles parked below the heater.
- When installed over hoists, minimum clearances to combustibles must be maintained from the upper most point of objects on the hoist.

4.4 Electrical

Heater must be electrically grounded in accordance with the following codes:

United States: Refer to National Electrical Code®, NFPA 70 - latest revision. Wiring must conform to the most current National Electrical Code®, local ordinances and any special diagrams furnished.

Canada: Refer to Canadian Electrical Code, CSA C22.1 Part 1 - latest revision.

4.5 Venting

Venting must be installed in accordance with the requirements within this manual and the following codes:

United States: Refer to National Fuel Gas Code NFPA 54/ANSI Z223.1 - latest revision.

Canada: Refer to Natural Gas and Propane Installation Code CSA B149.1 - latest revision.

4.6 High Altitude

These heaters are approved for installations up to 2000' (610 m) (US), 4500' (1370 m) (Canada) without modification. Consult factory if US installation is above 2000' (610 m) or Canadian installation is above 4500' (1370 m).

SECTION 5: MAJOR COMPONENTS

FIGURE 13: Major Component Descriptions - Standard Reflector

Burner with Tube Gasket

Must be installed with the flame observation window facing down.

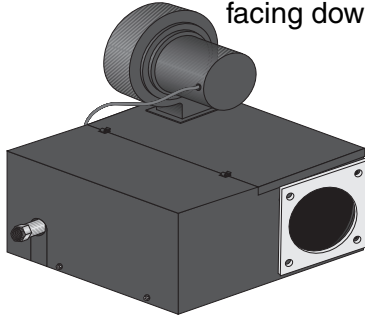
**Standard Reflector (Aluminum or Stainless Steel)**

Alternate overlap as shown on overview and on Page 19, Figure 17. Minimum overlap is 6" (16 cm).

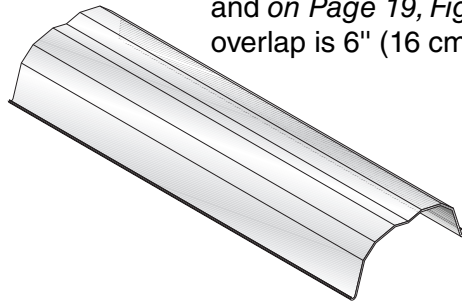
**Burner Tube**

Supplied in 10' (3 m) lengths. Burner tube is always the first tube after the burner.

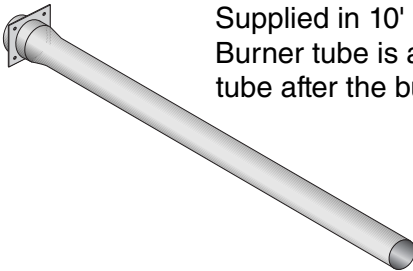
**Tube**

Hot rolled or heat treated aluminized tube supplied in 10' (3 m) lengths.

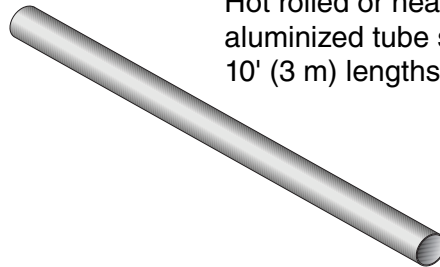
**Tube and Reflector Hanger with Clamp Package**

Position this hanger no more than 4" (10 cm) away from the burner.

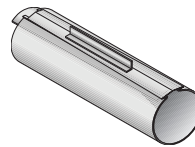
**Coupling Assembly with Lock****Tube and Reflector Hanger**

Suspend system from these hangers.

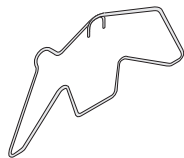
**Reflector End Cap**

Punch out center section to accommodate tube.

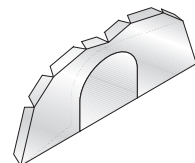
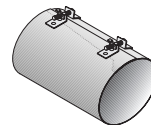
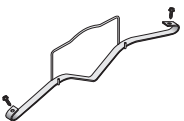
**Vent Adapter****Reflector Support Strap & Wire Form****Turbulator/Swirler**

Install turbulator/swirler as specified in the "Turbulator and Swirler Installation" charts. See Pages 23 and 24.

**Flex Gas Line with Shut Off Cock**

FIGURE 14: Major Component Descriptions - High Efficiency Reflector



Burner with Tube Gasket
Must be installed with the flame observation window facing down.

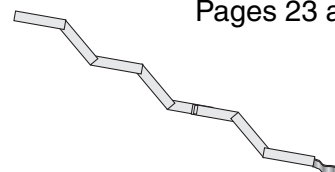
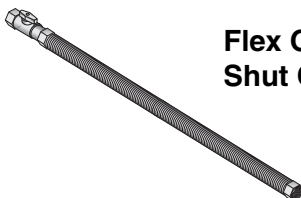
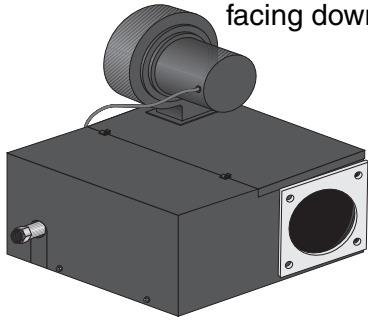
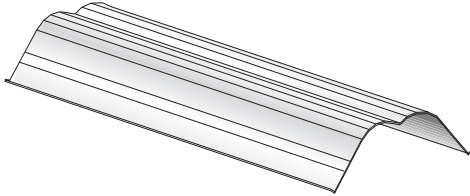

High Efficiency Reflector (Aluminum only)
Alternate overlap as shown on overview and on Page 19, Figure 17. Minimum overlap is 6" (16 cm).

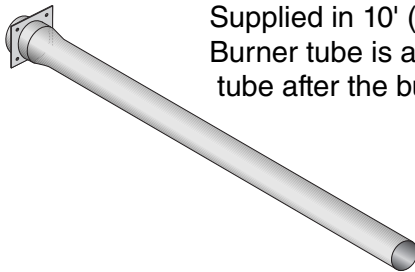

Burner Tube
Supplied in 10' (3 m) lengths. Burner tube is always the first tube after the burner.

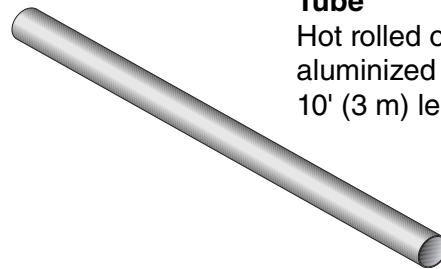

Tube
Hot rolled or heat treated aluminized tube supplied in 10' (3 m) lengths.

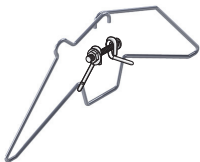

Tube and Reflector Hanger with Clamp Package-EF
Position this hanger no more than 4" (10 cm) away from the burner.

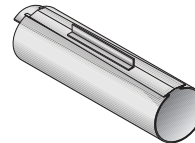

Coupling Assembly with Lock

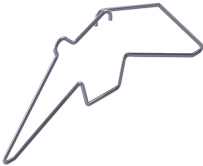

Tube and Reflector Hanger-EF
Suspend system from these hangers.

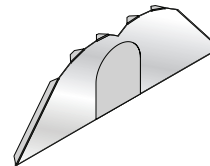

Reflector End Cap-EF
Punch out center section to accommodate tube.

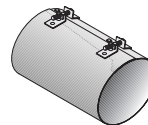

Vent Adapter

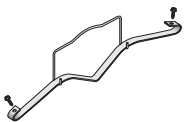

Reflector Support Strap & Wire Form-EF

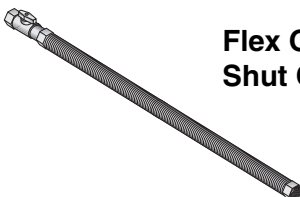

Flex Gas Line with Shut Off Cock

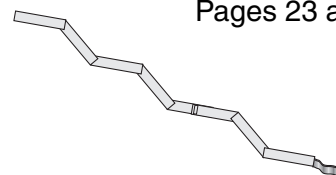

Turbulator/Swirlor
Install turbulator/swirlor as specified in the "Turbulator and Swirlor Installation" charts. See Pages 23 and 24.

5.1 Standard Parts List

Table 1: Contents of DF-Series Burner Carton

| Part No. | Description | DF-80 | DF-100 | DF-125 | DF-150 | DF-175 | DF-200 |
|-------------|---|-------|--------|--------|--------|--------|--------|
| 073XXXXX | Burner (Rate and Fuel Varies) | 1 | 1 | 1 | 1 | 1 | 1 |
| 90709700 | Blower Assembly with Cord | 1 | 1 | 1 | 1 | 1 | 1 |
| 02568200 | Gasket (Burner to Burner Tube) | 1 | 1 | 1 | 1 | 1 | 1 |
| 90709801 | Gasket (Blower to Burner) | 1 | 1 | 1 | 1 | 1 | 1 |
| 173101NA | Installation, Operation and Service Manual | 1 | 1 | 1 | 1 | 1 | 1 |
| 91201708 | Pipe Nipple (Black) 1/2" NPT x 4" | 1 | 1 | 1 | 1 | 1 | 1 |
| 94273914 | Hex Head Bolts 5/16" - 18 Rolok | 4 | 4 | 4 | 4 | 4 | 4 |
| 96411600 | Split Lock Washer | 4 | 4 | 4 | 4 | 4 | 4 |
| *91412200 | Flexible Stainless Steel Gas Hose, 1/2" NPT (US Models Only) | 1 | 1 | 1 | - | - | - |
| 91412203 | Flexible Stainless Steel Gas Hose, 3/4" NPT (US Models Only) | - | - | - | 1 | 1 | 1 |
| 91907302 | S-Hooks | 2 | 2 | 2 | 2 | 2 | 2 |
| 91911704 | Outside Air Collar | 1 | 1 | 1 | 1 | 1 | 1 |
| 94118106 | #8 x 3/8 Hex Washer Head (for Outside Air Collar) | 3 | 3 | 3 | 3 | 3 | 3 |
| 92311800 | Keps Nut | 4 | 4 | 4 | 4 | 4 | 4 |
| 03051501 | Turbulator Adapter | 1 | 1 | 1 | 1 | - | - |
| 03051502 | Turbulator 2.5' (76 cm), Aluminized Steel | 4 | 2 | 3 | 2 | - | - |
| **03051509K | Swirler Package - 10' (3 m) (Contains Qty 2 - 62" Swirlers) | - | - | - | 1 | - | 1 |
| **03051510K | Swirler Package - 15' (4.5 m) (Contains Qty 3 - 62" Swirlers) | - | - | - | - | 1 | - |
| **03051511K | Swirler Package - 20' (6 m) (Contains Qty 4 - 62" Swirlers) | - | - | 1 | - | - | - |

*Canadian models: Rubber (Type 1) Gas Hoses available as an accessory. See Page 51.

**Contents located in box separate from the burner.

Table 2: Contents of Standard Core and Extension Packages

| Part No. | Description | Core Packages | | | | Extension Packages | | | |
|----------|--|---------------|-------------|-------------|--------------|--------------------|-------------|-------------|--------------|
| | | Aluminized | | | | Aluminized | | | |
| | | 10' (3m) | 20' (6m) | 30' (9m) | 40' (12m) | 10' (3m) | 20' (6m) | 30' (9m) | 40' (12m) |
| 91409408 | Tube, HT Aluminized, 10' (3 m) | - | 1 | 2 | 3 | 1 | 2 | 3 | 4 |
| 03051101 | Burner Tube, ALUMI-THERM® Steel, 10' (3 m) | - | - | 1 | 1 | - | - | - | - |
| 03051601 | Burner Tube, HT ALUMI-THERM® Steel, 10' (3 m) | 1 | 1 | - | - | - | - | - | - |
| 01312700 | Coupling Assembly | - | 1 | 2 | 3 | 1 | 2 | 3 | 4 |
| 02750303 | Standard Reflector, 8' (3.5 m) | 2 | 3 | 4 | 6 | 2 | 3 | 4 | 6 |
| 02750800 | End Cap | 2 | 2 | 2 | 2 | - | - | - | - |
| 03090100 | Tube and Reflector Hanger | 2 | 3 | 4 | 5 | 1 | 2 | 3 | 4 |
| 91907302 | S-Hook | 2 | 3 | 4 | 5 | 1 | 2 | 3 | 4 |
| 03050010 | Reflector Support Package (Strap, Wire Form, Screws) | 1 | 2 | 3 | 5 | 2 | 3 | 4 | 6 |
| 91107720 | U-Clip Package | 1 | 1 | 1 | 1 | 1 | 1 | 1 | 1 |
| 90502701 | Vent Adapter | 1 | 1 | 1 | 1 | - | - | - | - |
| 01318901 | Tube Clamp Package | 1 | 1 | 1 | 1 | - | - | - | - |

Table 2: Contents of Standard Core and Extension Packages

| Part Number | CP10ALUM | CP20ALUM | CP30ALUM | CP40ALUM | EXP10ALUM | EXP20ALUM | EXP30ALUM | EXP40ALUM |
|-------------|----------|----------|----------|----------|-----------|-----------|-----------|-----------|
|-------------|----------|----------|----------|----------|-----------|-----------|-----------|-----------|

Table 3: Contents of High Efficiency Core and Extension Packages

| Part No. | Description | Core Packages | | | | Extension Packages | | | |
|----------|---|---------------|-------------|-------------|--------------|--------------------|-------------|-------------|--------------|
| | | Aluminized | | | | Aluminized | | | |
| | | 10' (3m) | 20' (6m) | 30' (9m) | 40' (12m) | 10' (3m) | 20' (6m) | 30' (9m) | 40' (12m) |
| 91409408 | Tube, HT Aluminized, 10' (3 m) | - | 1 | 2 | 3 | 1 | 2 | 3 | 4 |
| 03051101 | Burner Tube, ALUMI-THERM- Steel, 10' (3 m) | - | - | 1 | 1 | - | - | - | - |
| 03051601 | Burner Tube, HT ALUMI-THERM- Steel, 10' (3 m) | 1 | 1 | - | - | - | - | - | - |
| 01312700 | Coupling Assembly | - | 1 | 2 | 3 | 1 | 2 | 3 | 4 |
| 02750313 | High Efficiency Reflector, 8' (3.5 m) | 2 | 3 | 4 | 6 | 2 | 3 | 4 | 6 |
| 02750802 | End Cap-EF | 2 | 2 | 2 | 2 | - | - | - | - |
| 03090102 | Tube and Reflector Hanger-EF | 2 | 3 | 4 | 5 | 1 | 2 | 3 | 4 |
| 91907302 | S-Hook | 2 | 3 | 4 | 5 | 1 | 2 | 3 | 4 |
| 03050012 | Reflector Support Package-EF (Strap, Wire Form, Screws) | 1 | 2 | 3 | 5 | 2 | 3 | 4 | 6 |
| 91107720 | U-Clip Package | 1 | 1 | 1 | 1 | 1 | 1 | 1 | 1 |
| 90502701 | Vent Adapter | 1 | 1 | 1 | 1 | - | - | - | - |
| 01318902 | Tube Clamp Package-EF | 1 | 1 | 1 | 1 | - | - | - | - |

Table 4: DF-Series Component Package Guide

| Model | Tubing Length | Standard Reflector Core Packages | High Efficiency Reflector Core Packages |
|--------|---------------|----------------------------------|---|
| | Minimum | Aluminized | Aluminized |
| DF-80 | 20' (6 m) | CP20ALUM | CP20ALUMEF |
| DF-100 | 30' (9 m) | CP30ALUM | CP30ALUMEF |
| DF-125 | 30' (9 m) | CP30ALUM | CP30ALUMEF |
| DF-150 | 40' (12 m) | CP40ALUM | CP40ALUMEF |
| DF-175 | 40' (12 m) | CP40ALUM | CP40ALUMEF |
| DF-200 | 50' (15 m) | CP30ALUM + EXP20ALUM | CP30ALUMEF + EXP20ALUMEF |

Additional tubing length may be added to heater. Tubing must be heat-treated, aluminized or porcelain coated. Any additional tubing lengths are considered as vent length for length determination. Maximum venting length for minimum heater length is 45' (13.7 m) total.

Table 5: DF-Series Component Package Guide - High Efficiency Reflector

| Model | Tubing Length | Core Packages | |
|--------|---------------|------------------------|--------------------------|
| | Minimum | Hot Rolled | Aluminized |
| DF-80 | 20' (6 m) | CP20HRSEF | CP20ALUMEF |
| DF-100 | 30' (9 m) | CP30HRSEF | CP30ALUMEF |
| DF-125 | 30' (9m) | CP30HRSEF | CP30ALUMEF |
| DF-150 | 40' (12 m) | CP40HRSEF | CP30ALUMEF |
| DF-175 | 40' (12 m) | CP40HRSEF | CP40ALUMEF |
| DF-200 | 50' (15 m) | CP30HRSEF + EXP20HRSEF | CP30ALUMEF + EXP20ALUMEF |

Although not recommended, additional tube lengths may be added to the heater. Tubing must be hot-rolled steel, aluminized (heat-treated) or porcelain coated. Additional tube lengths beyond the specified minimum tubing length are considered vent pipe for length determination.

SECTION 6: HEATER INSTALLATION**⚠ WARNING****Severe Injury Hazard**

Secure burner to burner tube with nuts and lockwashers.

Hang heater with materials with a minimum working load of 75 lbs (33 kg).

Failure to follow these instructions can result in death, injury or property damage.

Expansion and contraction of the tube dictates that the minimum suspension lengths must be maintained. See table on Page 17, Figure 15.

⚠ WARNING**Cut/Pinch Hazard**

Wear protective gear during installation, operation and service.

Edges are sharp.

Failure to follow these instructions can result in injury.

To ensure your safety and comply with the terms of the warranty, all units must be installed in accordance with these instructions.

The gas or the electrical supply lines must not be used to support the heater.

Do not locate the gas or electric supply lines directly over the path of the flue products from the heater.

The heater must be installed in a location that it is readily accessible for servicing.

The heaters must be installed in accordance with clearances to combustibles as indicated on the rating plate and in this instruction manual.

The minimum and maximum gas inlet pressures must be maintained as indicated on the rating plate.

Typical installation configurations are shown on Page 17, Figure 15.

FIGURE 15: Critical Hanger Placement

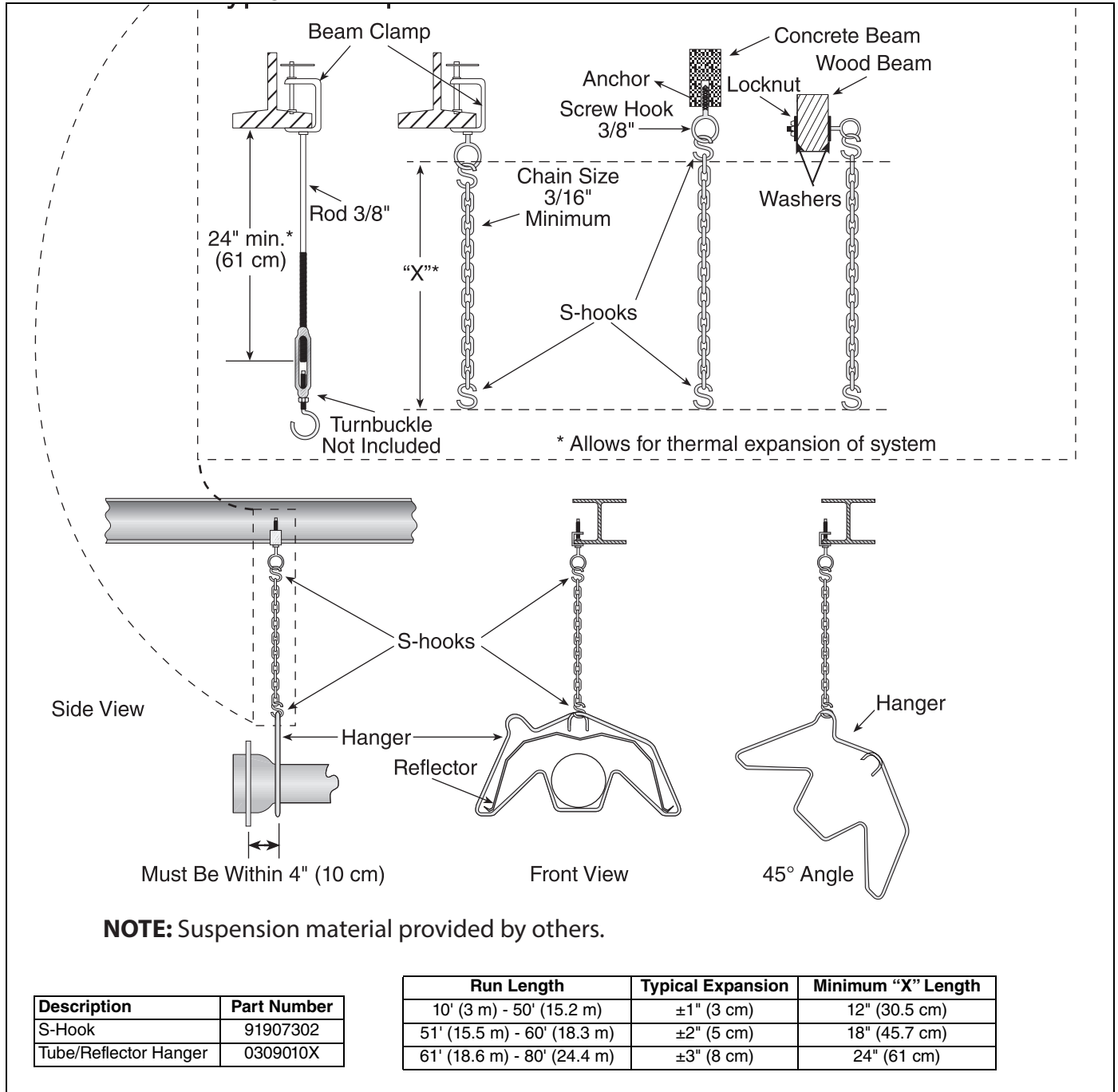

FIGURE 16: Linear Heater Assembly Overview

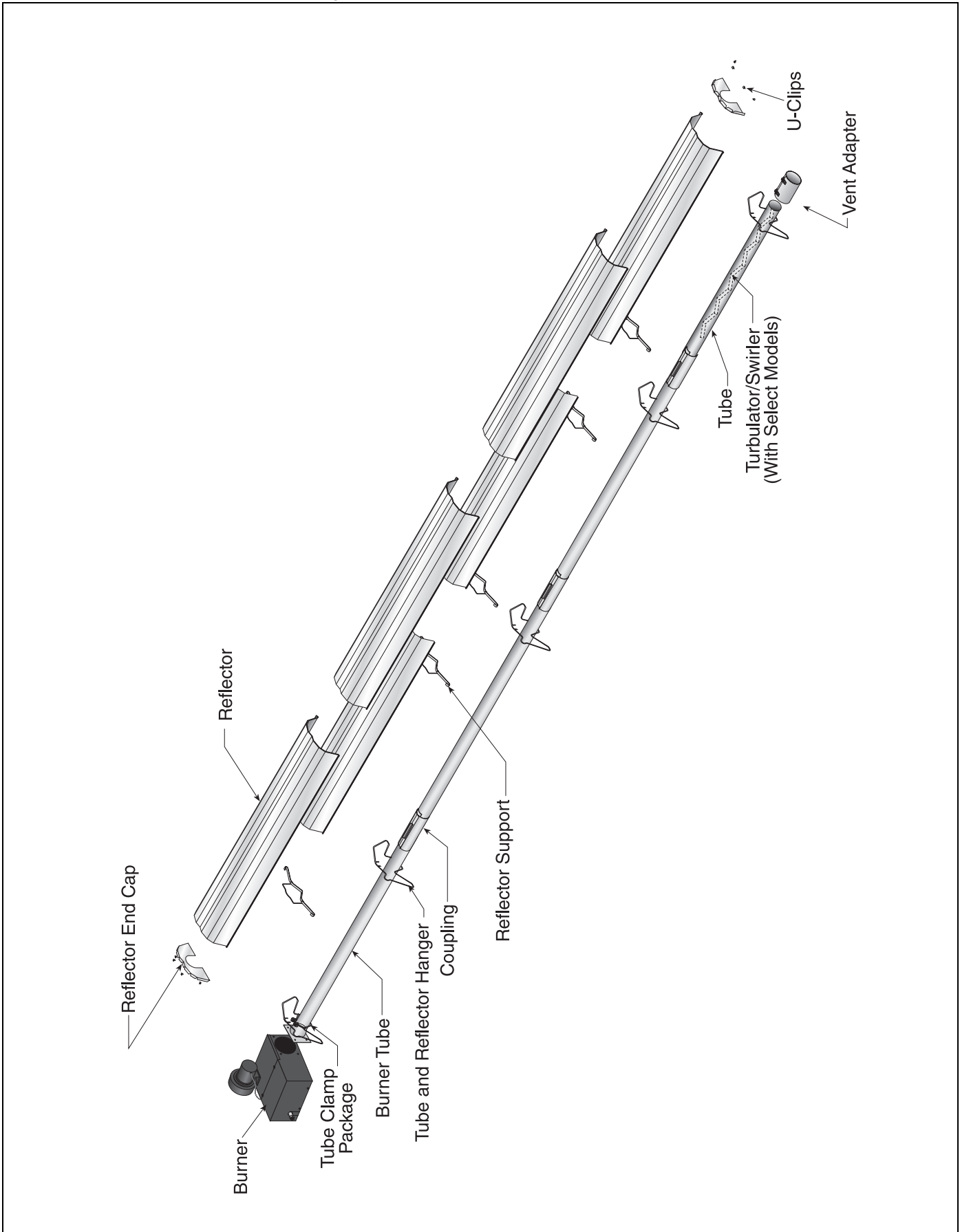

FIGURE 17: Linear Heater Layout Overview

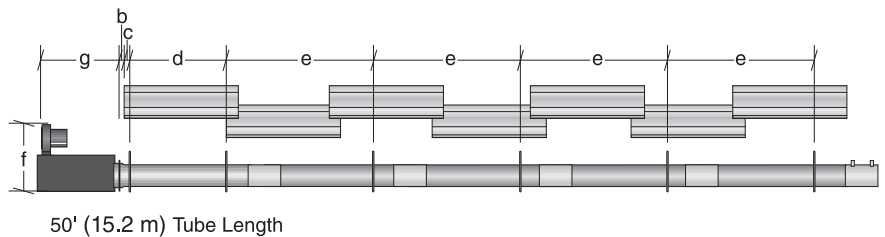
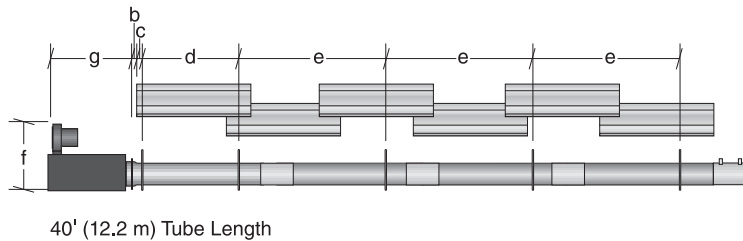
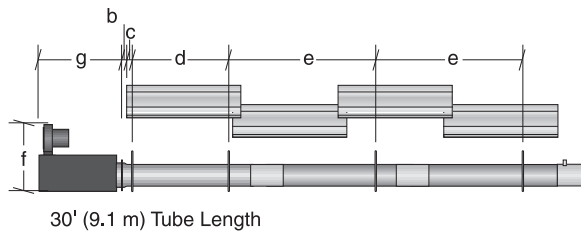
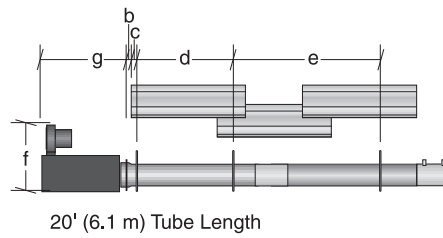
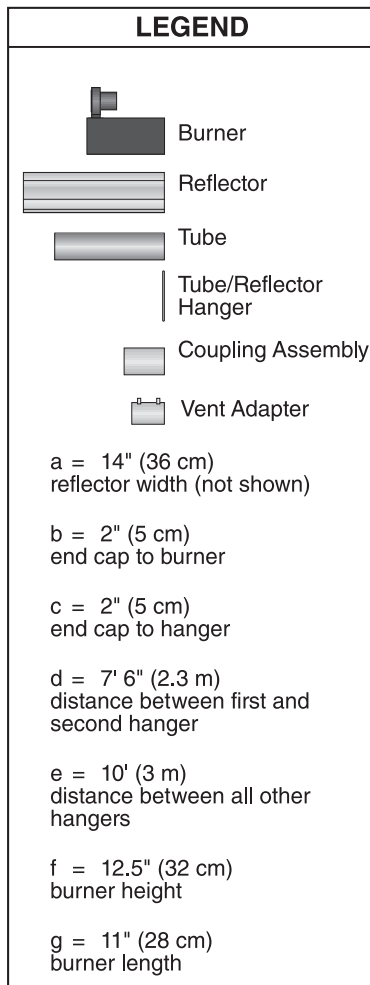
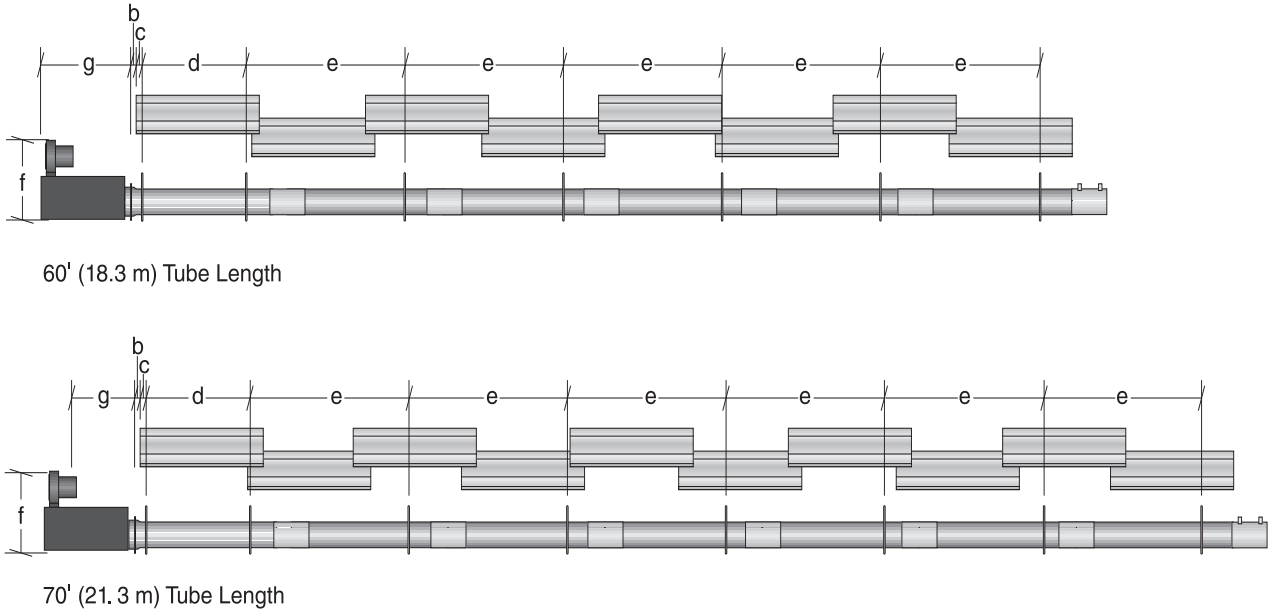
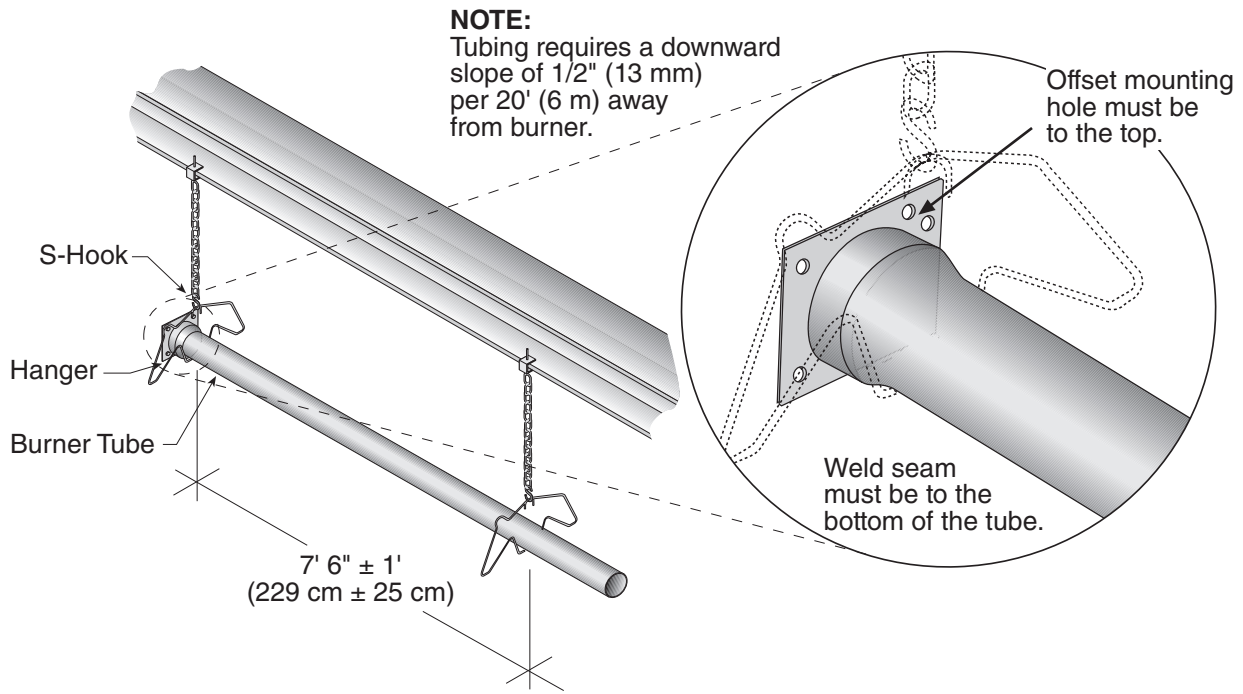

FIGURE 18: Linear Heater Layout Overview (Continued)



Step 6.1 Burner Tube Installation

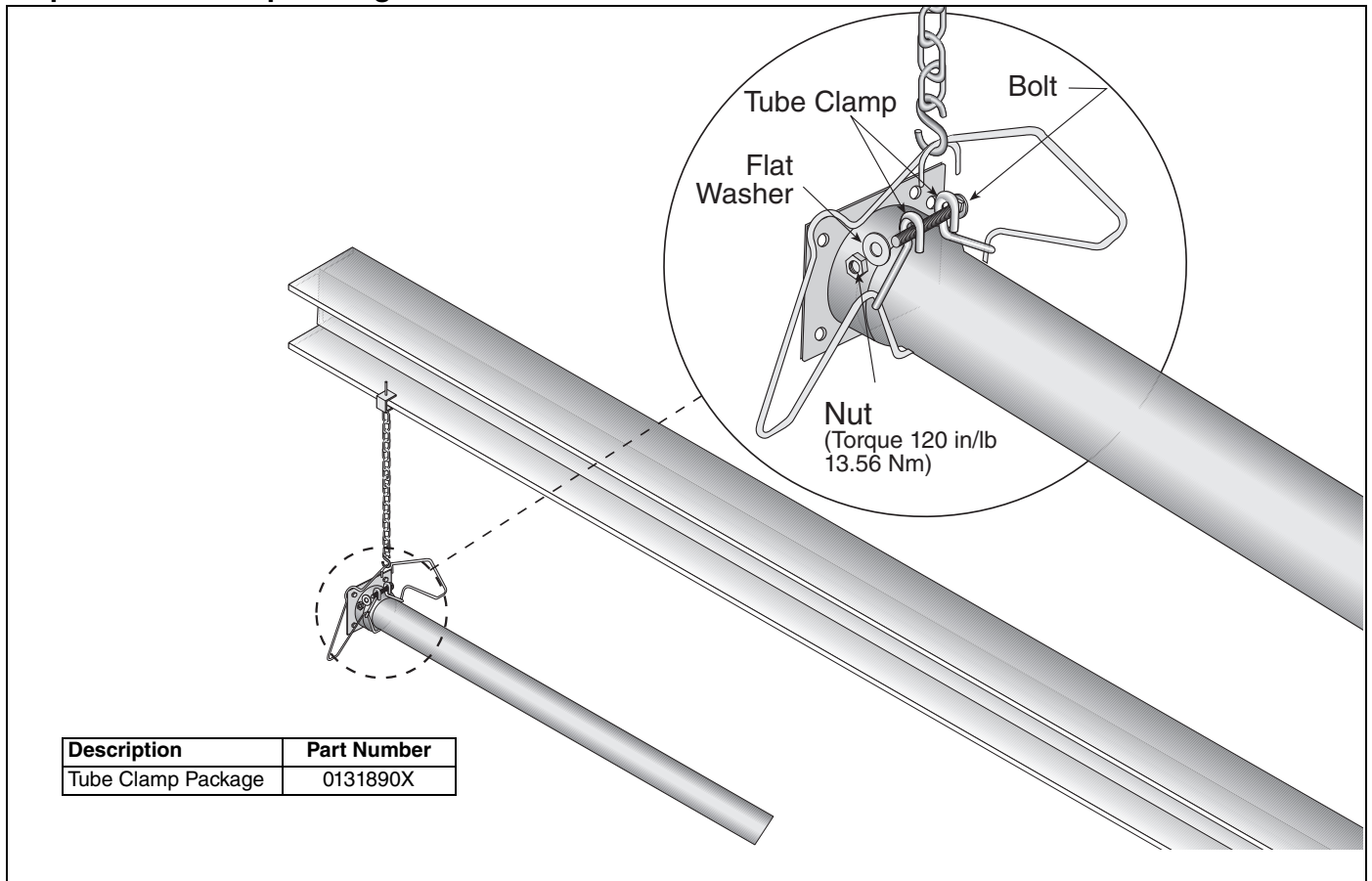

| Description | Part Number |
|-----------------------|-------------|
| Burner Tube | 03051XXX |
| S-Hook | 91907302 |
| Tube/Reflector Hanger | 0309010X |

Step 6.2 Tube Clamp Package Installation

Step 6.3 Coupling and Tube Assembly

NOTE: Prior to coupling installation review Swirler Installation on Model DF-175 requires swirler tab to be installed under coupling. Swirler installation for this model must be complete prior to coupling installation.

A Close coupling and slide opposite end into tab. Position tab underneath guide rail.

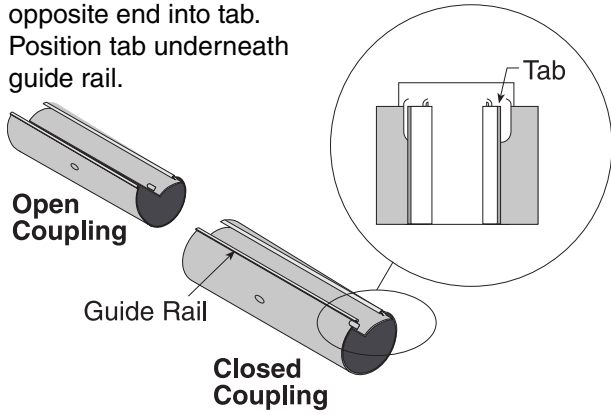

B Insert wide end of slide bar/coupling lock into guide rail on opposite end of tabs. Slide the slide bar/coupling lock up the guide rail until snug (approximately 3" (8 cm) to 4" (10 cm)).

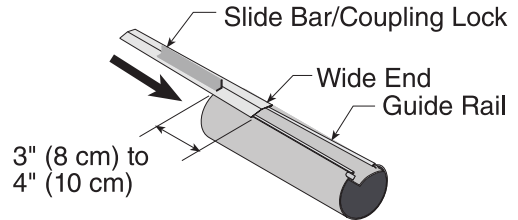

C Insert tubes into coupling until end of each tube rests against internal pins.

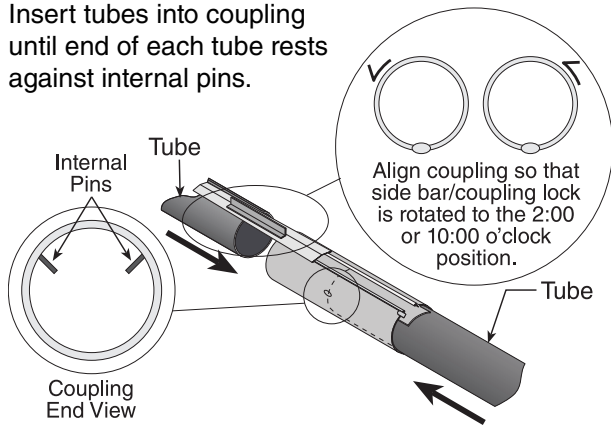

D

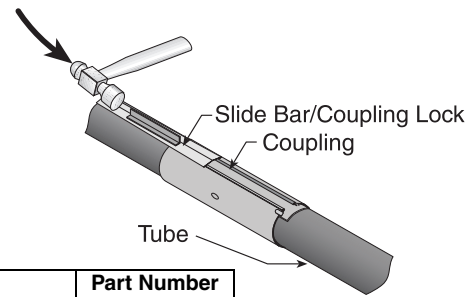

| Description | Part Number |
|-------------------------|-------------|
| Coupling | 01329600 |
| Slide Bar/Coupling Lock | 01329700 |
| Tube | 91409XXX |

Step 6.3.1 Coupling and Tube Assembly (Continued)

Tighten slide bar as shown below.

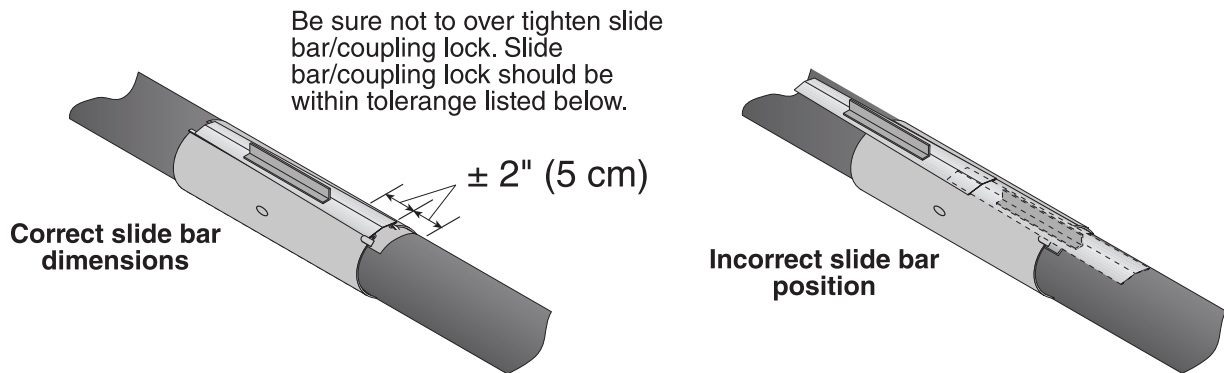

- Repeat Step 6.3 A - D until all tubes are assembled. See Page 23, Step 6.3.2.

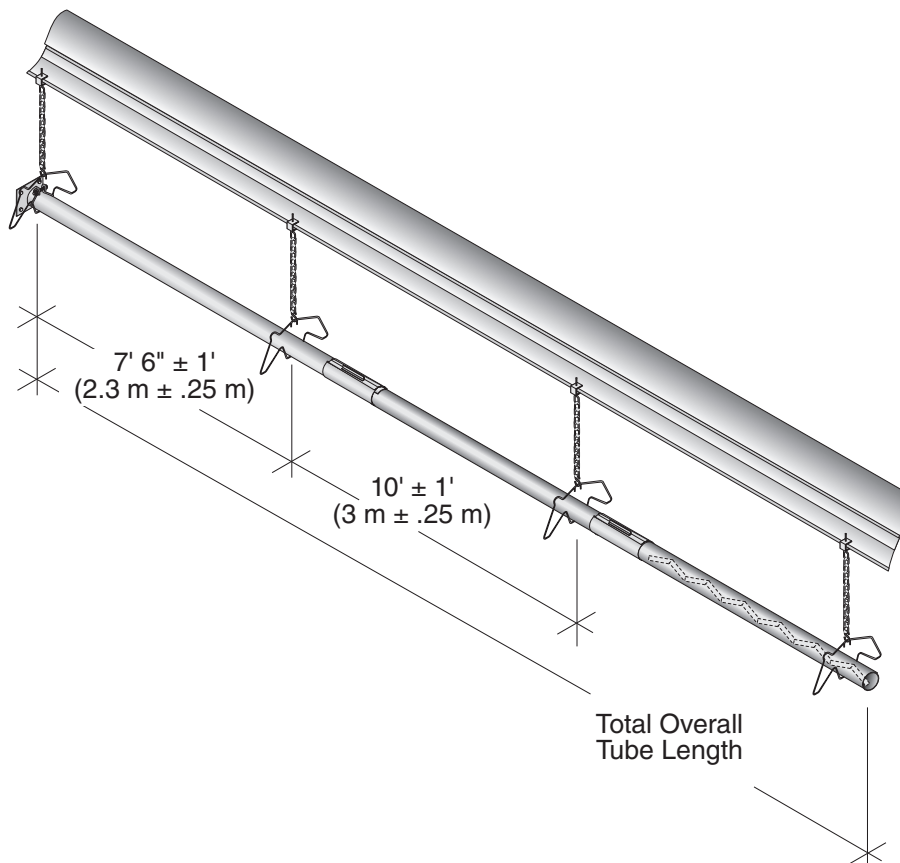
Step 6.3.2 Coupling and Tube Assembly (Continued)

| Model | Tube Length Minimum |
|--------|---------------------|
| DF-80 | 20' (6 m) |
| DF-100 | 30' (9 m) |
| DF-125 | 30' (9 m) |
| DF-150 | 40' (12 m) |
| DF-175 | 40' (12 m) |
| DF-200 | 50' (15 m) |

Step 6.4 Turbulator Installation

Install turbulator as specified in the "Turbulator Installation" chart below.

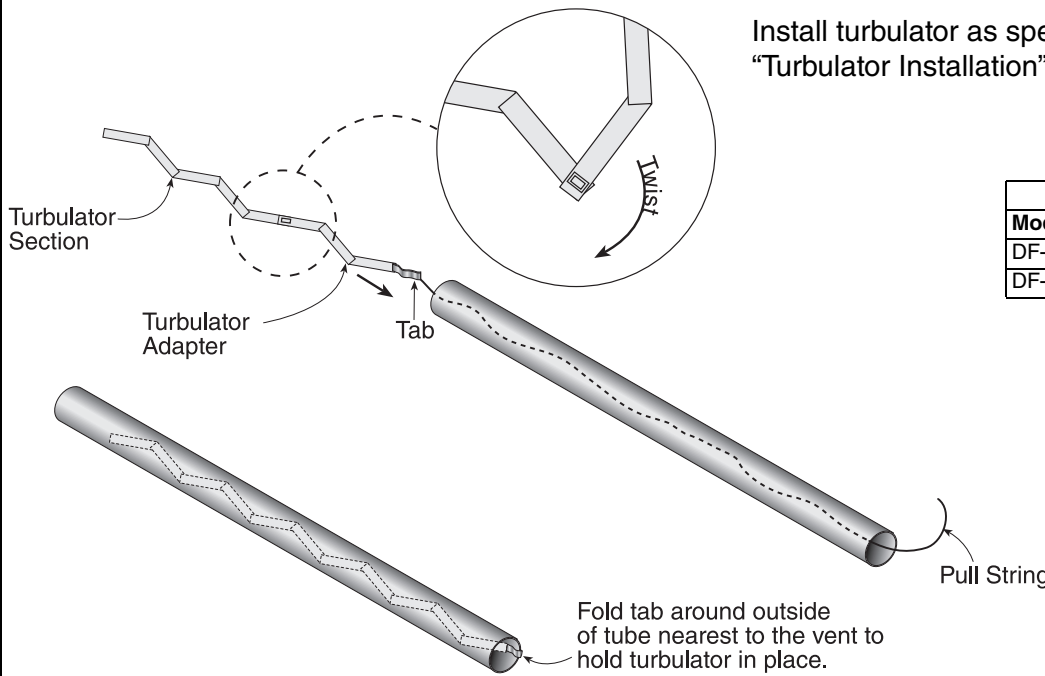

| Turbulator Installation | |
|-------------------------|-----------------------|
| Model | Tube Section |
| DF-80 | 2nd 10' (3 m) Section |
| DF-100 | 3rd 10' (3 m) Section |

| Description | Part Number |
|-----------------------------------|-------------|
| Turbulator Adapter 2.5' (76.2 cm) | 03051501 |
| Turbulator Section 2' (61 cm) | 03051502 |
| Tube | 91409XXX |

Step 6.5 Swirler Installation

| Swirler Installation Chart | | |
|----------------------------|-----------------------|------------------------|
| Model | Tube Section | Swirler Qty |
| DF-125 | 3rd 10' (3m) Section | 1 Starter + 3 Adapters |
| DF-150 | 4th 10' (3m) Section | 1 Starter + 1 Adapter |
| DF-175 | 4th 10' (3 m) Section | 1 Starter + 2 Adapters |
| DF-200 | 5th 10' (3 m) Section | 1 Starter + 1 Adapter |

| Description | Part Number |
|-----------------------------|-------------|
| Swirler Starter 62" (1.6 m) | 03051506 |
| Swirler Adapter 62" (1.6 m) | 03051507 |
| Tube | 91409XXX |

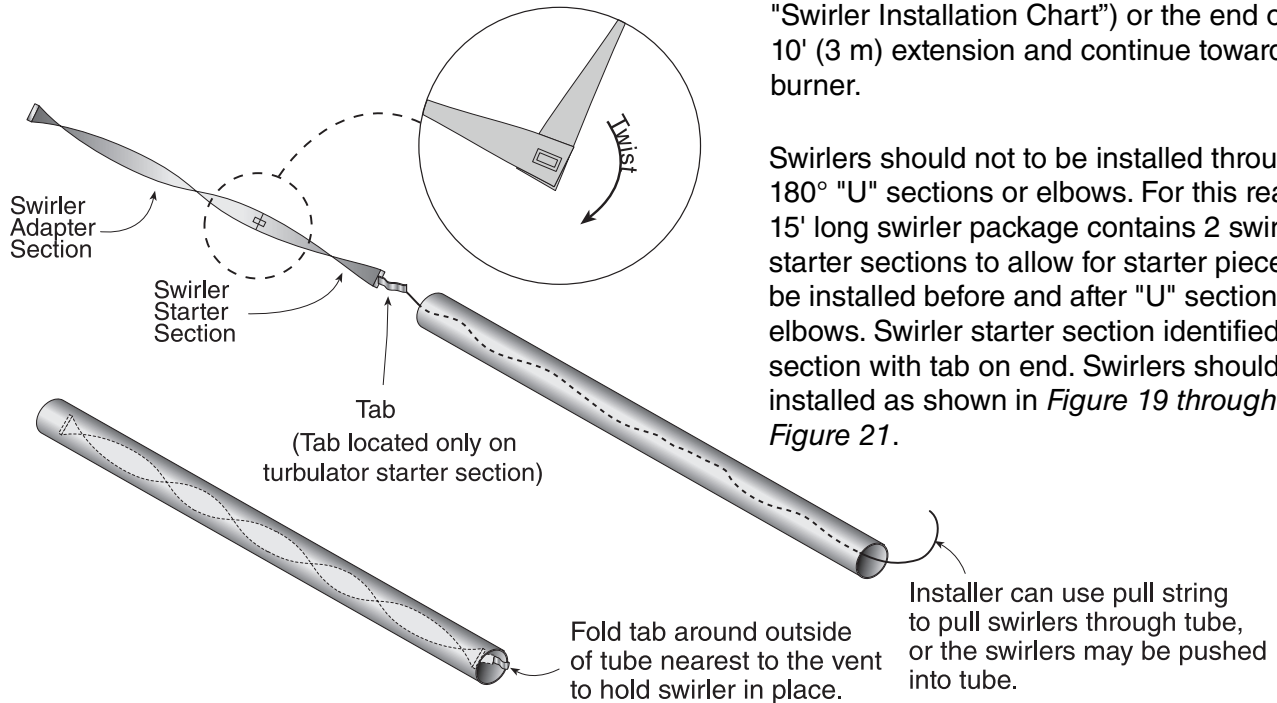

Swirler installation required for models specified in chart.

Begin installing swirler at end of tube section as described in the "Swirler Installation Chart" and continue towards burner.

Note: If heater length is extended 10' (3 m) beyond the specified minimum heat exchanger length swirler can begin in either the specified tube section (according to the "Swirler Installation Chart") or the end of the 10' (3 m) extension and continue towards burner.

Swirlers should not be installed through 180° "U" sections or elbows. For this reason, 15' long swirler package contains 2 swirler starter sections to allow for starter pieces to be installed before and after "U" sections and elbows. Swirler starter section identified as section with tab on end. Swirlers should be installed as shown in *Figure 19 through Figure 21*.

FIGURE 19: Swirler Installation Model: DF-175, 40° Straight Tube; Swirler Package - 15' (4.5 m) (p/n 03051510K)

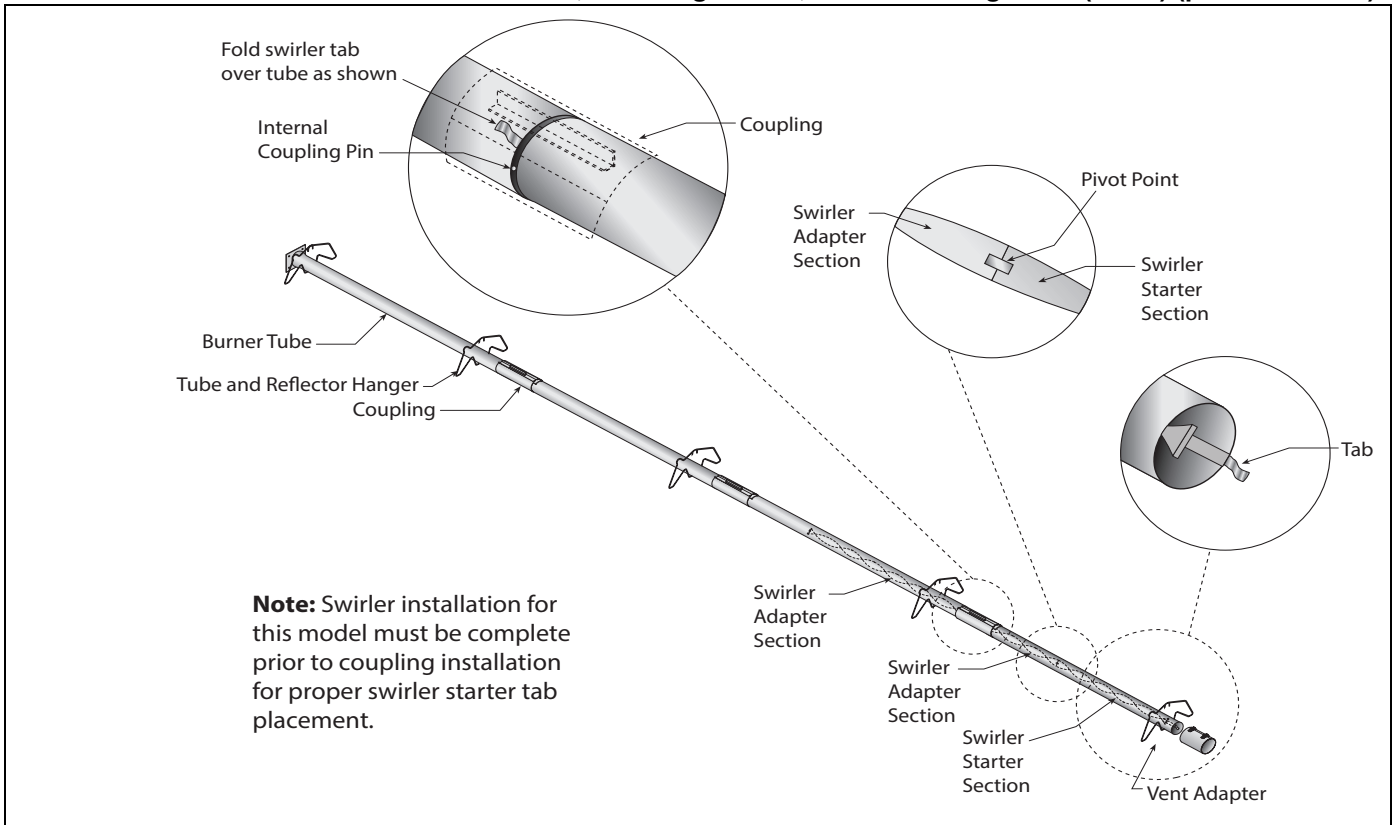
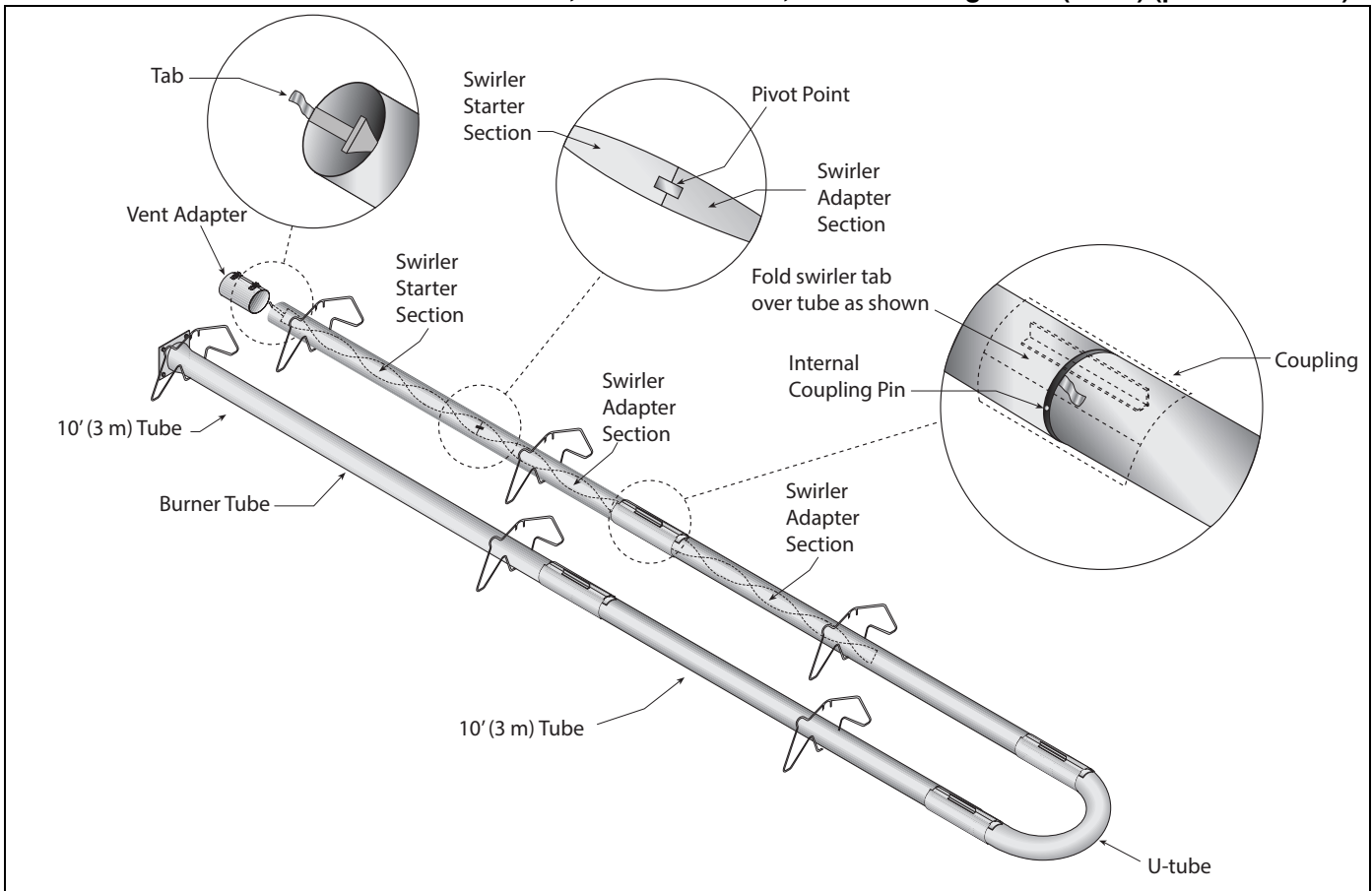
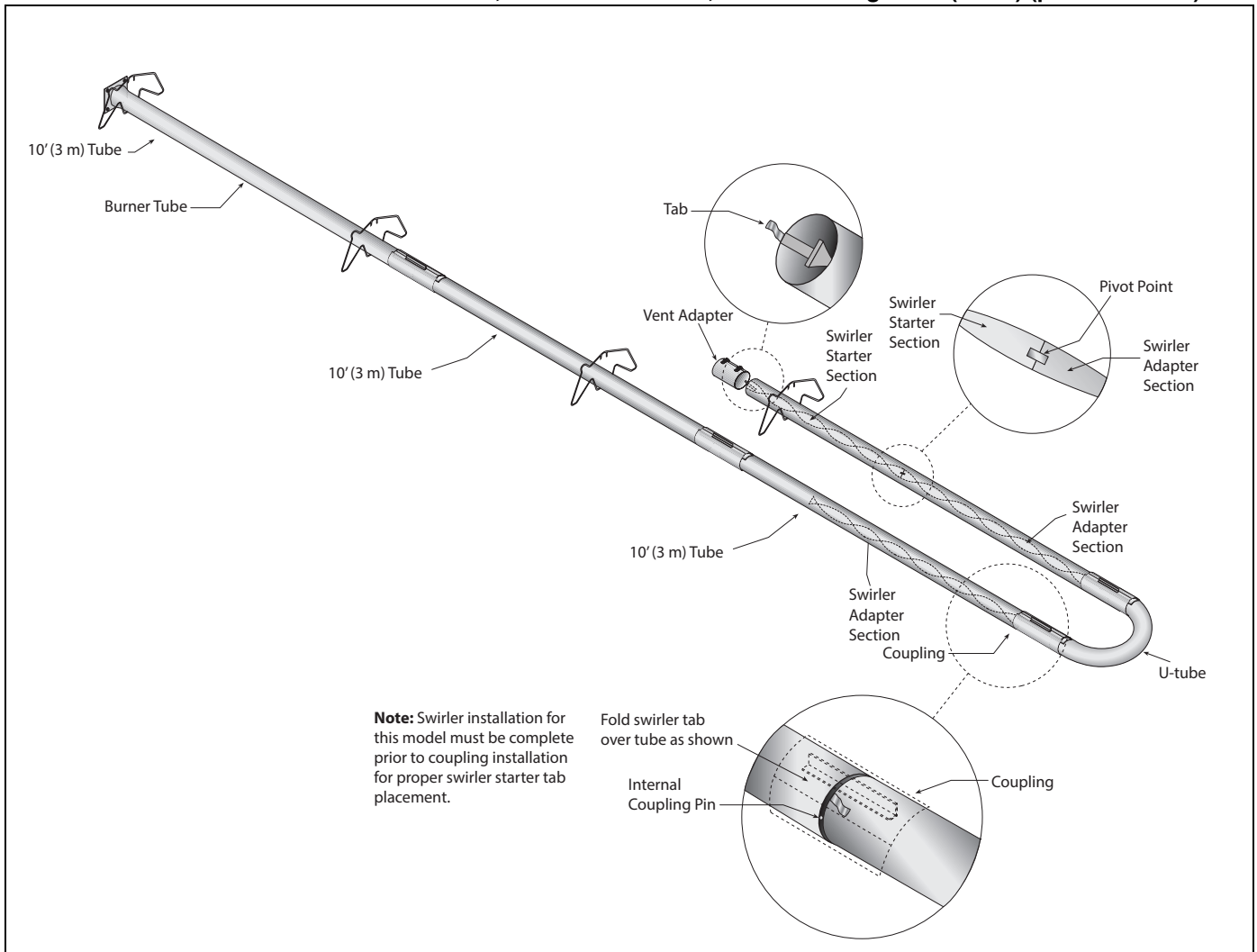

FIGURE 20: Swirler Installation Model: DF-175, 40° Even U-Tube; Swirler Package - 15' (4.5 m) (p/n 03051510K)



See page 30 for U-Tube installation instructions.

FIGURE 21: Swirler Installation Model: DF-175, 40' Uneven U-Tube; Swirler Package - 15' (4.5 m) (p/n 03051510K)



See page 30 for U-Tube installation instructions.

FIGURE 22: Swirler Installation Model: DF-200, 50' Straight Tube; Swirler Package - 10' (3 m) (p/n 03051509K)

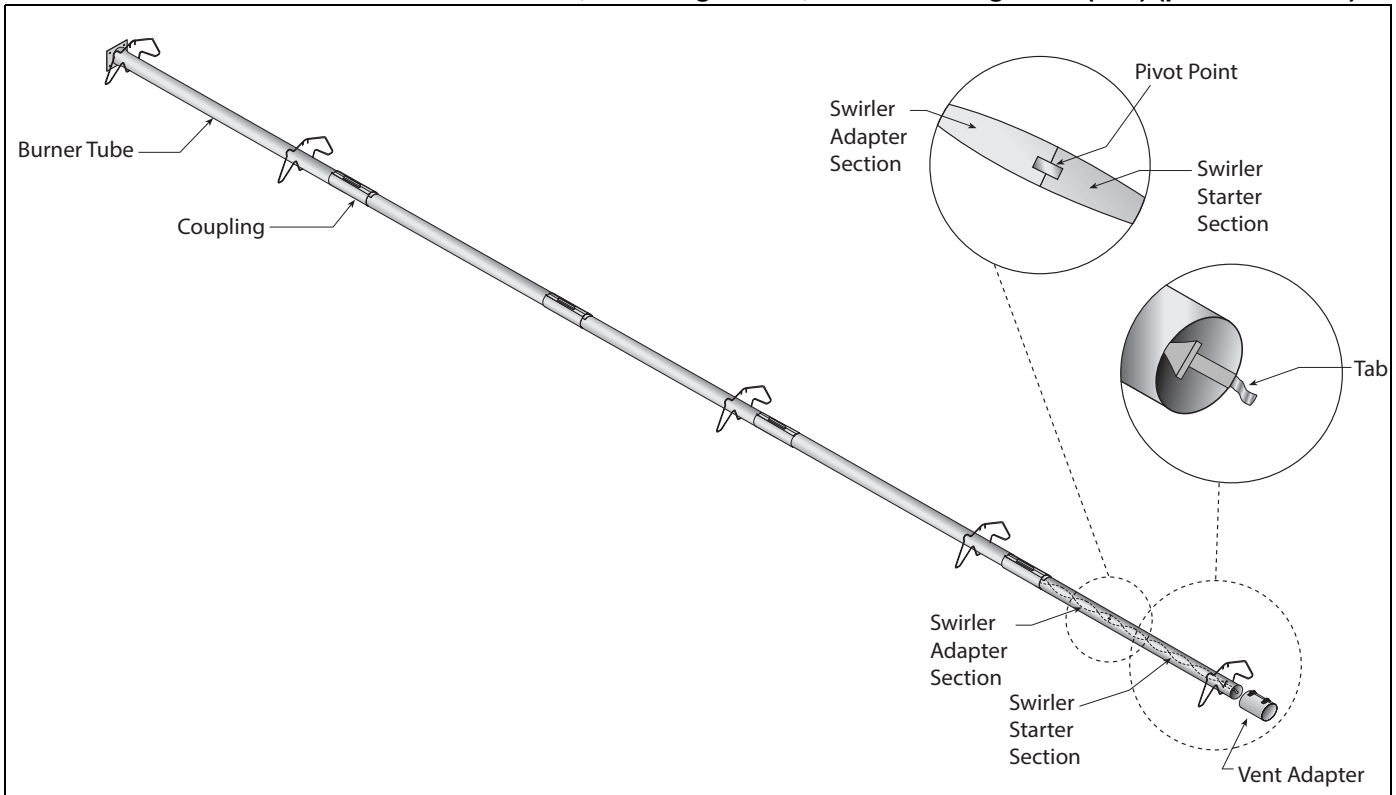
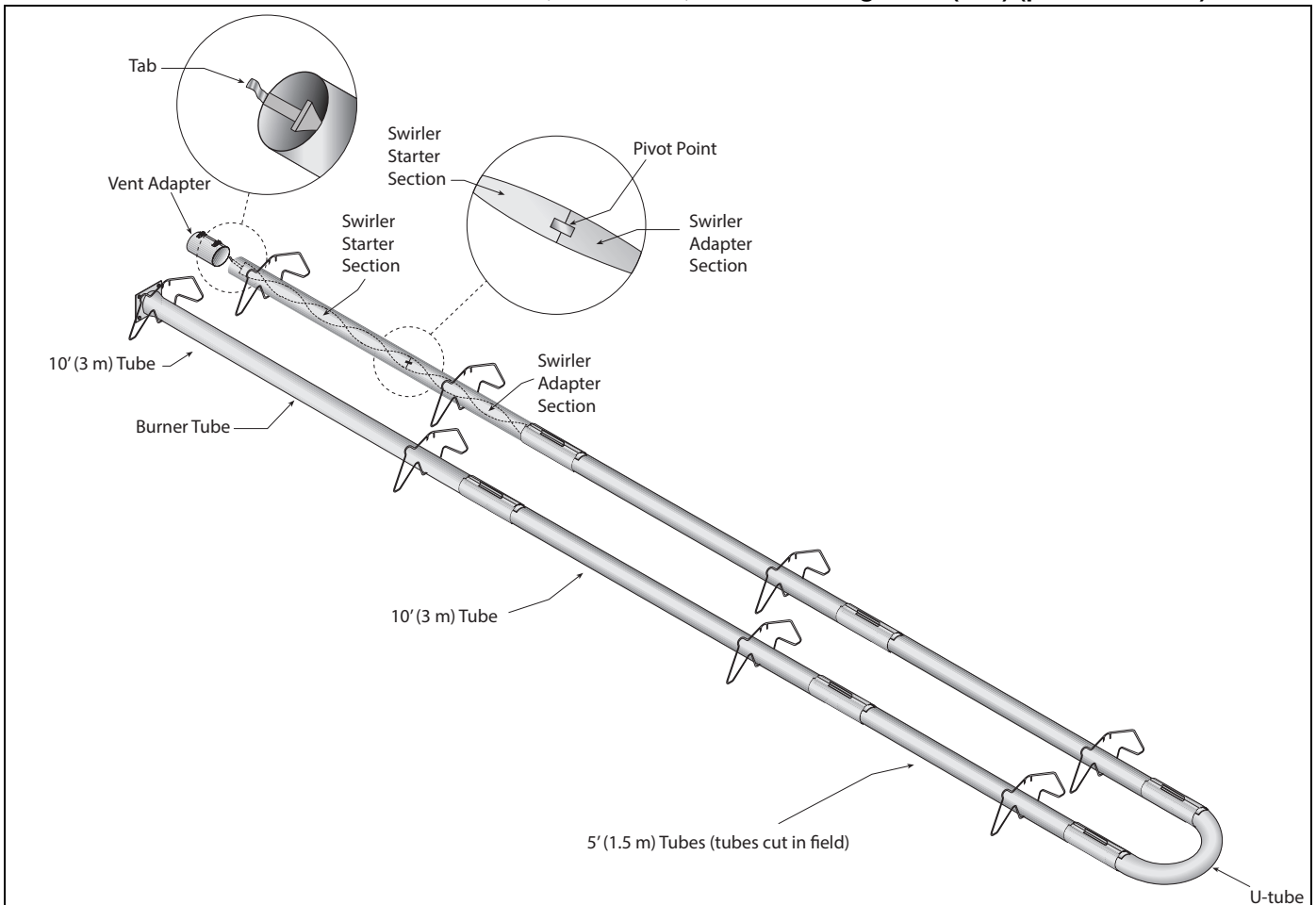

FIGURE 23: Swirler Installation Model: DF-200, 50' U-Tube; Swirler Package - 10' (3 m) (p/n 03051509K)



See page 30 for U-Tube installation instructions.

Step 6.6 Reflector Installation

⚠ WARNING**Fire Hazard**

Support reflector with reflector hanger and support strap.

Reflector must not touch tube.

Failure to follow these instructions can result in death, injury or property damage.

NOTE: All tube surfaces must be covered by a reflector, except for a U-tube.

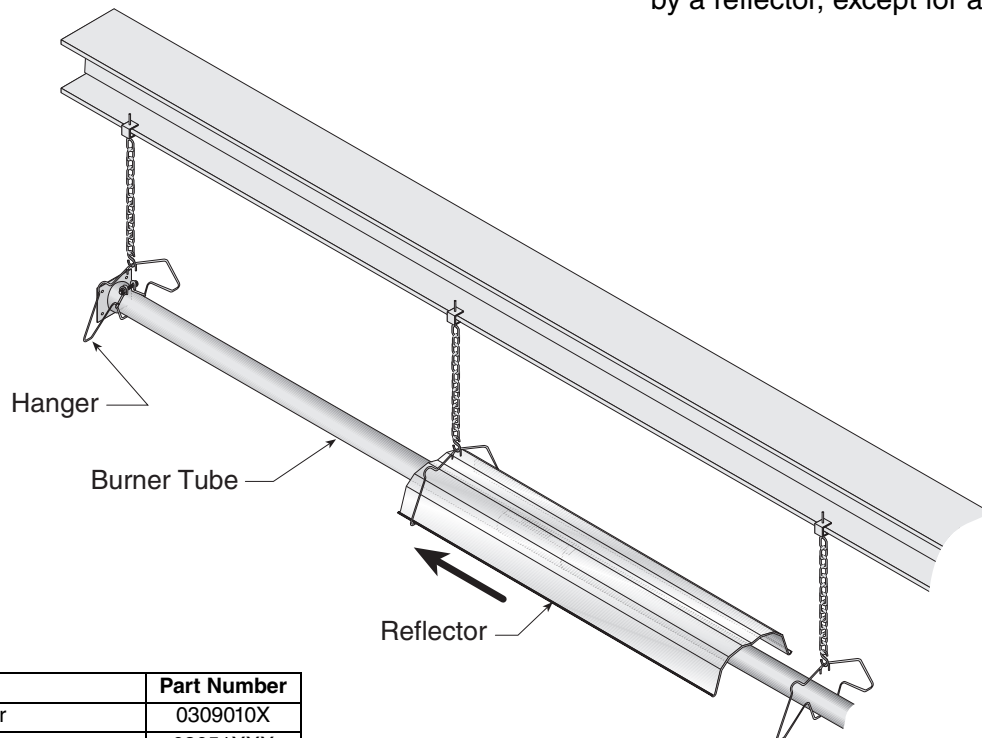

| Description | Part Number |
|------------------------|-------------|
| Tube/Reflector Hanger | 0309010X |
| Burner Tube | 03051XXX |
| Reflector 96" (244 cm) | 027503XX |

Step 6.6.1 Reflector, U-Clip and Reflector Support Installation

The pictorial drawings of the heater construction in *Section 6* are schematic only and provide a general guideline of where hangers, reflector supports and U-clips are to be installed.

To ensure proper expansion and contraction movement of the reflectors, a combination of U-clips and reflector supports are used. The positioning of

reflector supports and U-clips depend on the individual installation. Use either pop rivets or sheet metal screws instead of u-clips when installing end caps and joint pieces in areas where impact and high wind may be a factor. The following rules must be observed.

1. Slide first reflector after burner a minimum 2" (4 cm) through first hanger and ensure reflector end cap is securely fastened via U-clips, pop rivets, or sheet metal screws. Position reflector support with tight screws in middle of first reflector.

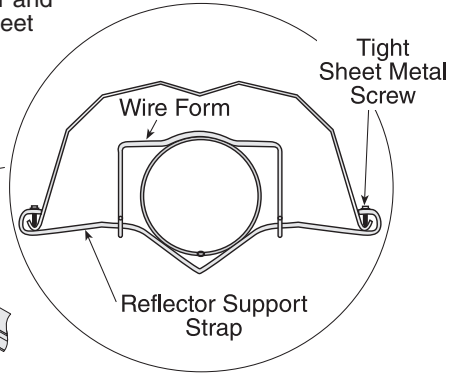
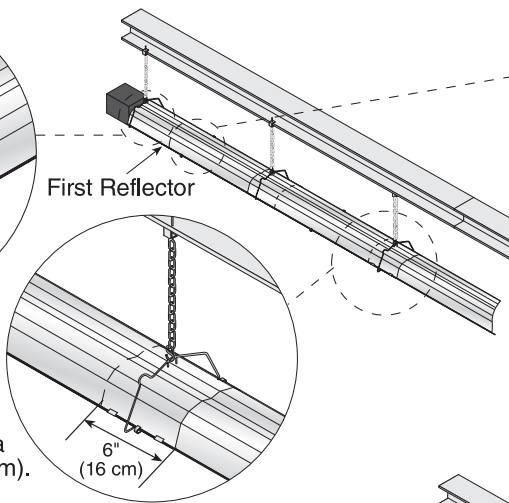
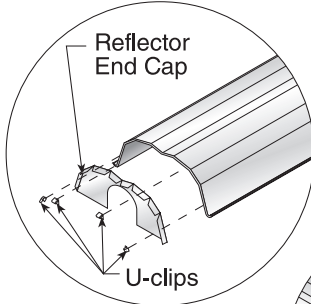

Overlap must be a minimum of 6" (16 cm).

2. The overlap at the first and second reflector is a **slip overlap**. Thereafter, every third reflector joint is a slip overlap. A slip overlap is achieved by either:

- a.) both reflectors lay inside a hanger.
- (No reflector support needed.)
- b.) using a reflector support with loose screws at the reflector overlap.

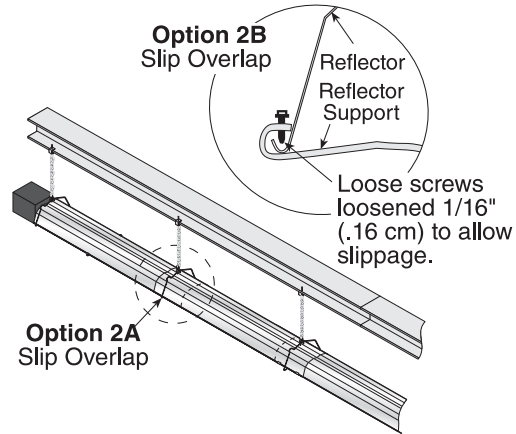

3. The remaining reflector overlaps require a **non-slip overlap** connection. To affix the reflectors together in a non-slip overlap either:

- a.) use reflector support and tight screws.
- b.) if both reflectors lay inside a hanger, u-clips or sheet metal screws may be used.

This section of three reflectors joined together must be affixed to the tube with at least one reflector support with tight screws.

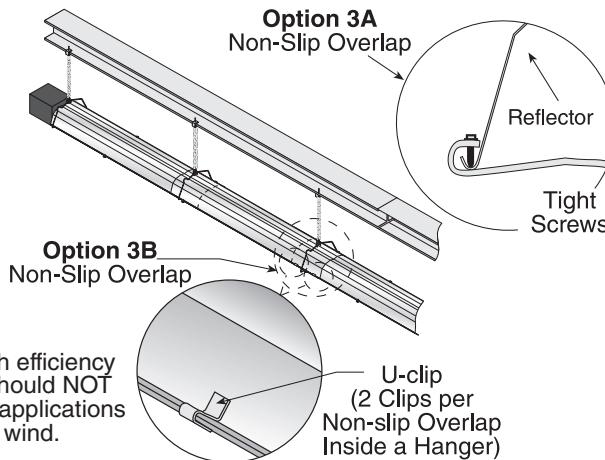

| Description | Part Number |
|----------------------------------|-----------------|
| Reflector Support Package | 0305001X |
| Wire Form | 9190800X |
| Reflector Support Strap | 0305000X |
| Screw #8 x 3/4" | 94320812 |
| U-Clip Package | 91107720 |
| Reflector End Cap | 027508XX |

NOTE: High efficiency reflectors should NOT be used in applications exposed to wind.

Step 6.7 Burner Installation

Install combustion blower by placing blower gasket between blower and top of burner. Secure blower to top of burner using (4) supplied #10-32 locknuts. Install flue collar if connecting an outside air inlet. Plug blower cord into receptacle on rear of burner.

Note: Do NOT face blower air inlet towards hinged access panel if connecting fresh air inlet. Doing so will interfere with access panel.

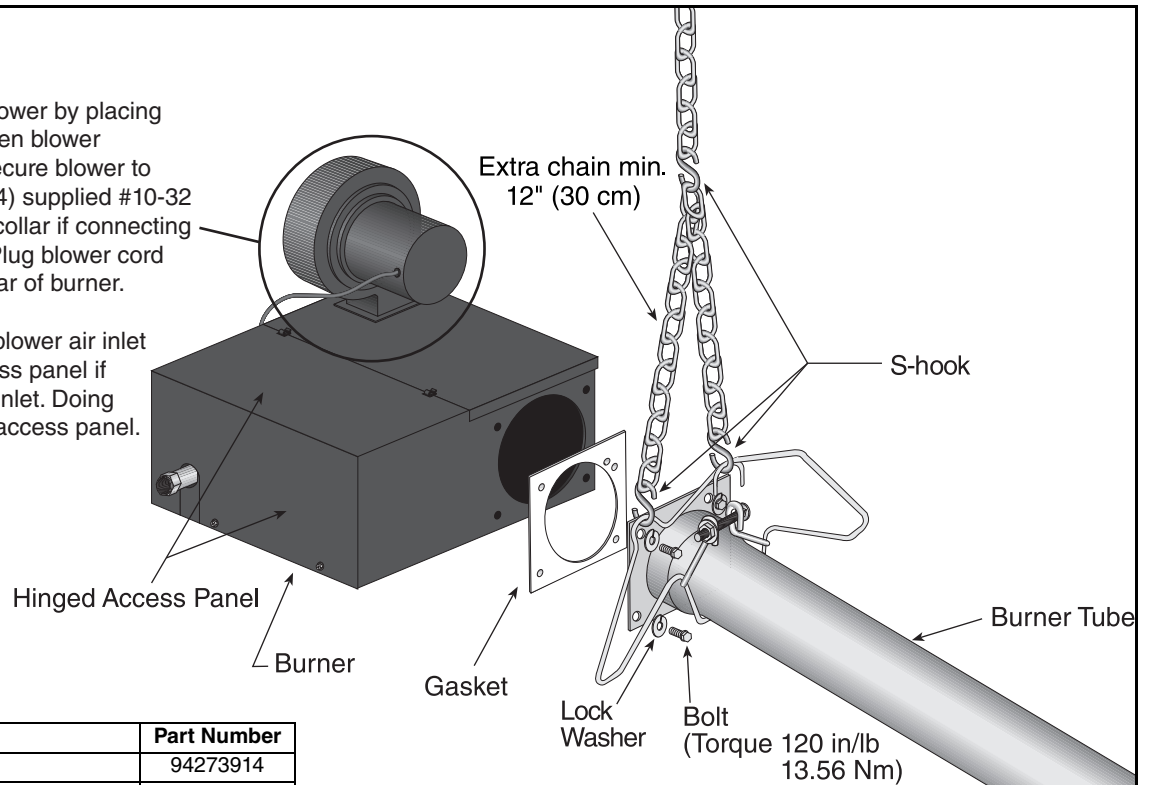

| Description | Part Number |
|------------------------------|-------------|
| Bolt | 94273914 |
| Lock Washer | 96411600 |
| Blower | 90709700 |
| Blower to Burner Gasket | 90709801 |
| Locknuts # 10-32 | 92311800 |
| Outside Air Flue Collar | 91911700 |
| #8 x 3/8 Hex Washer Head | 94118106 |
| Burner to Burner Tube Gasket | 02568200 |

NOTE: To ensure proper orientation, attach burner tube with tube weld facing downward.

SECTION 7: OPTIONAL HEATER ACCESSORIES**⚠ WARNING****Cut/Pinch Hazard**

Wear protective gear during installation, operation and service.

Edges are sharp.

Failure to follow these instructions can result in injury.

7.1 U-Tube Configuration

Heaters are approved for optional U-tube configurations.

The U-tube may be installed in either a standard horizontal position, a 45° position or in an opposite 45° position as shown on *Page 7, Figure 7 through Page 8, Figure 9*. When using a U-tube configuration, the following additional rules must be adhered to:

- A minimum of 10' (3 m) on DF-80 and a minimum of 15' (4.5 m) on DF-100/125/150/175/200 is required between the burner and the U-tube.
- The correct turbulator/swirler (*See Page 24, Step 6.4*) must be installed in the last standard section of the tube.
- The burner must never be operated in a tilted position.
- The heater must be properly supported at all locations. *See Page 34, Figure 25.*

FIGURE 24: U-Tube Heater Assembly Overview

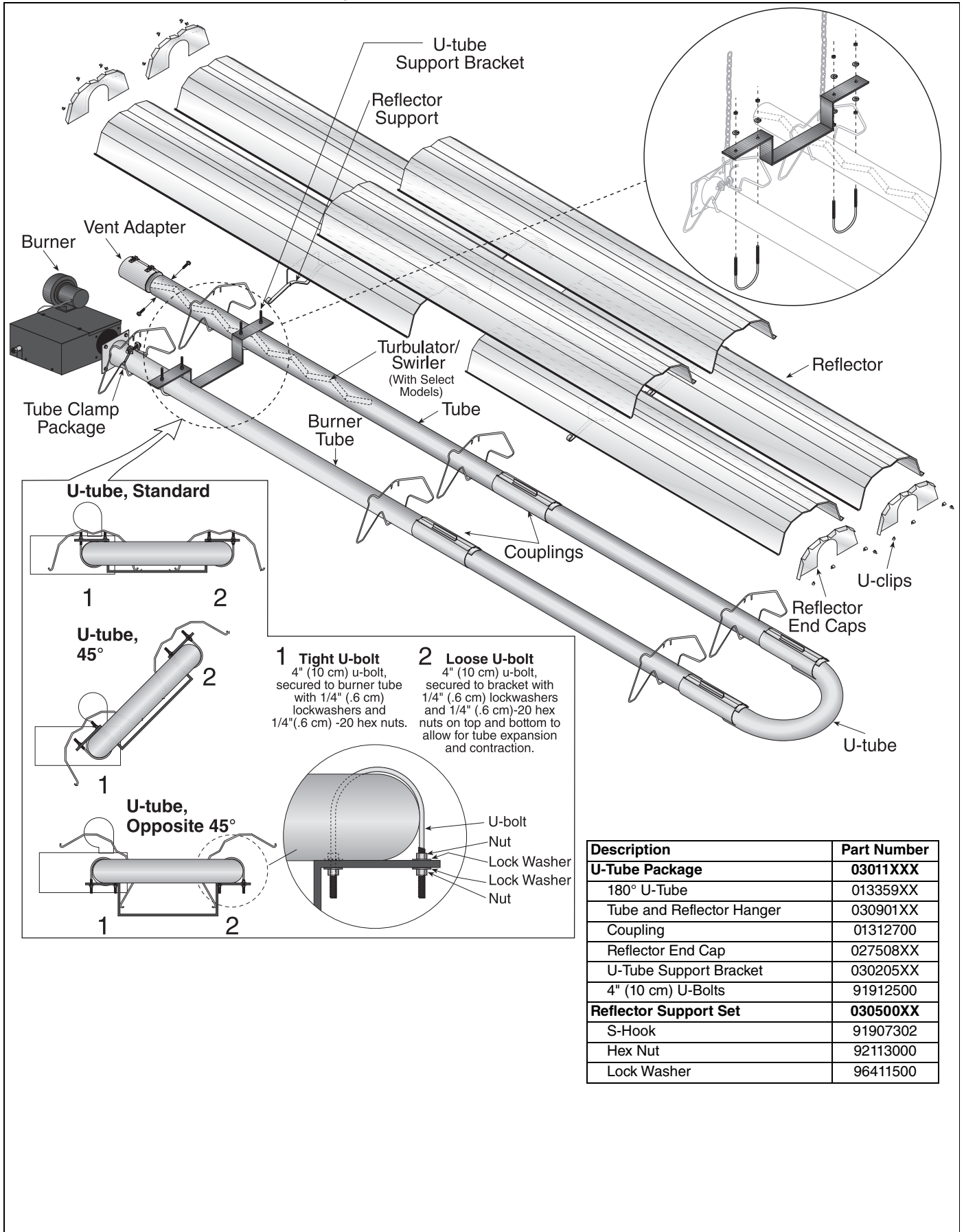



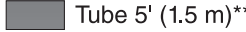
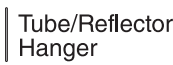





FIGURE 25: U-Tube Heater Layout Overview

| LEGEND | |
|---|--------------------------|
|  | Burner |
|  | Reflector |
|  | Tube 10' (3.0 m) |
|  | Tube 5' (1.5 m)** |
|  | Tube/Reflector Hanger |
|  | Coupling Assembly |
|  | U-tube |
|  | Vent Adapter (Not Shown) |

a = 14" (36 cm)
Reflector Width (Not Shown)

b = 2" (5 cm)
End Cap to Burner

c = 2" (5 cm)
End Cap to Hanger

d = 7' 6" (2.3 m)
Distance Between First and Second Hangers

e = 10' (3.0 m)
Distance Between All Other Hangers

f = 5' (1.5 m)
Distance Between Last Full Tube Hanger and Half Tube Hanger

g = 12.5" (32 cm) Burner Length

h = 11" (28 cm) Burner Height

* Requires the last **reflector** before the u-tube to be cut in half for use on both sides.

** Requires the last **tube** before the u-tube to be cut in half for use on both sides.

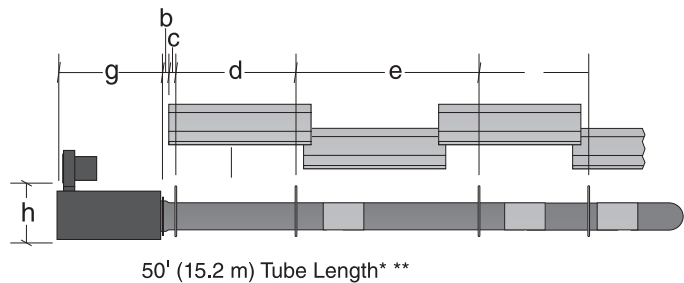
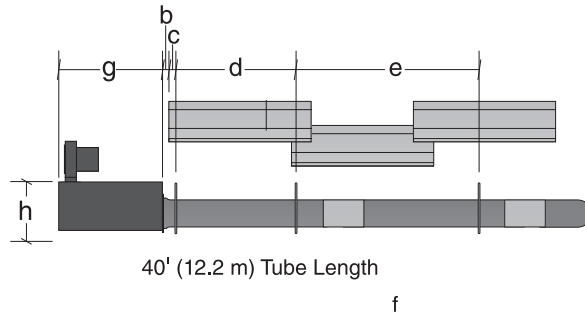
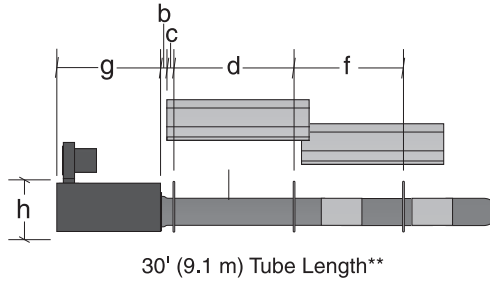
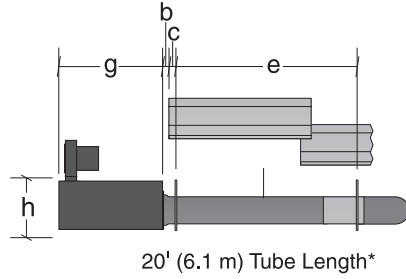
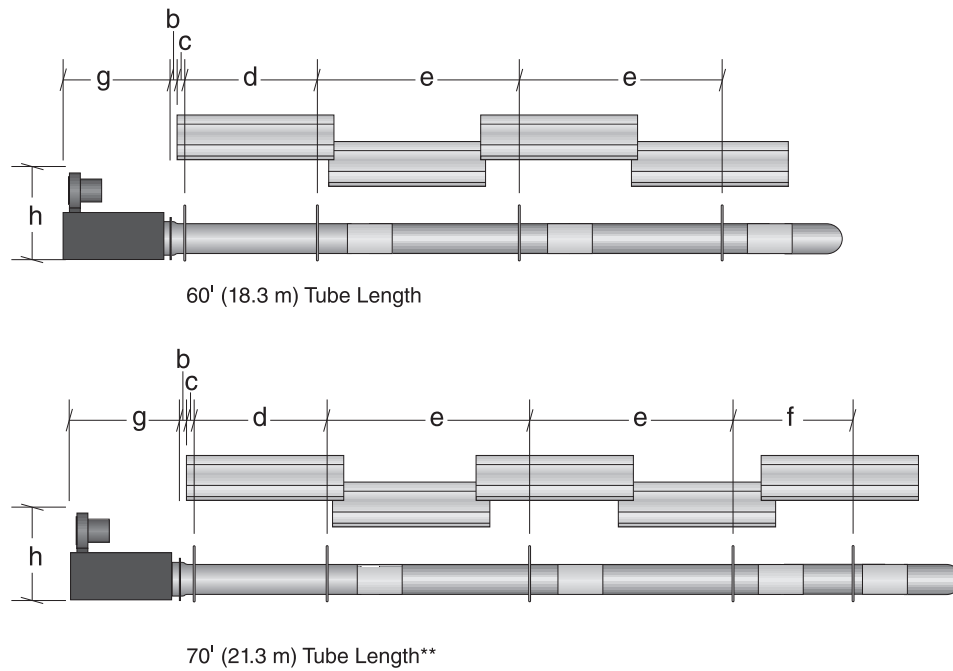
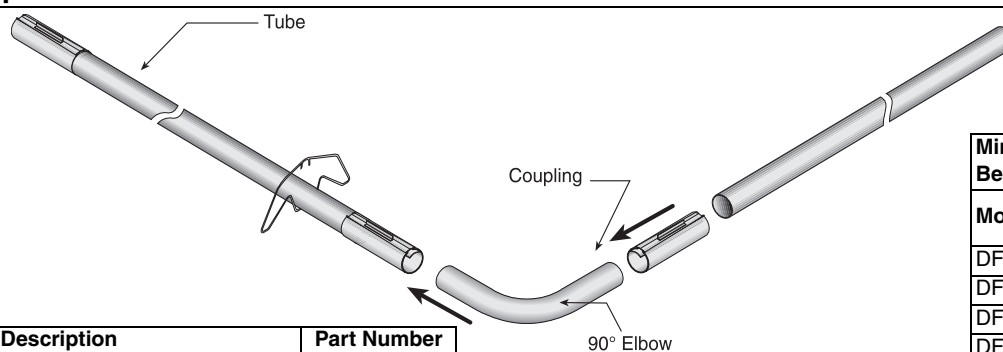

FIGURE 26: U-Tube Layout Overview (Continued)



7.2 Elbow Package Configuration

Step 7.2.1 Elbow Installation



| Description | Part Number |
|-----------------------|-----------------|
| Elbow Package | 0271870X |
| 90° Elbow | 01335801 |
| Coupling | 01312700 |
| Reflector End Cap | 0275080X |
| Reflector Joint Piece | 0275090X |
| U-Clip Package | 91107720 |

| Minimum Distance Required Between Burner and Elbow | |
|--|------------------|
| Model | Minimum Distance |
| DF-80 | 10' (3 m) |
| DF-100 | 15' (4.5 m) |
| DF-125 | 15' (4.5 m) |
| DF-150 | 15' (4.5 m) |
| DF-175 | 15' (4.5 m) |
| DF-200 | 15' (4.5 m) |

Step 7.2.2 Elbow Installation

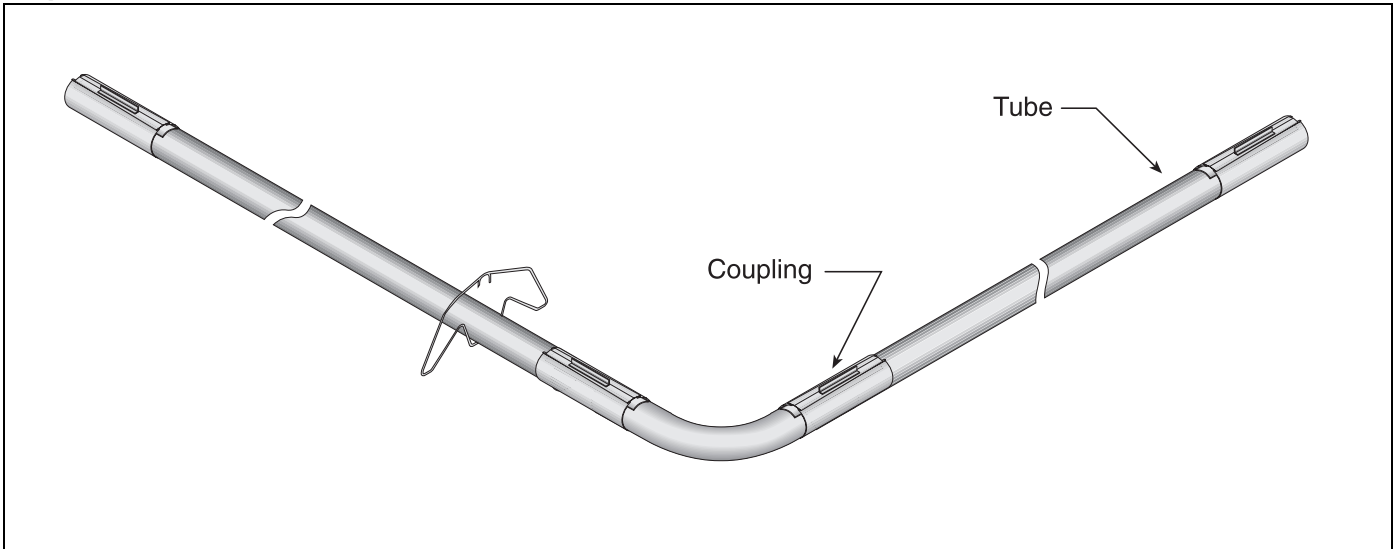

Step 7.2.3 Reflector Joint Installation

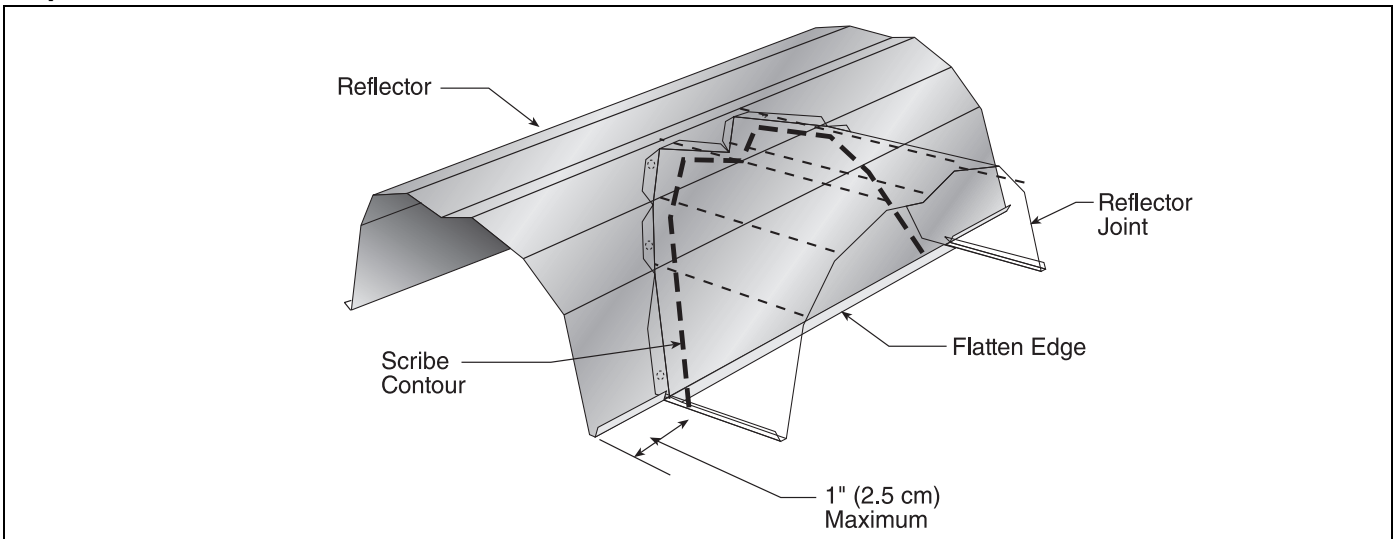

Step 7.2.4 Reflector Joint Installation

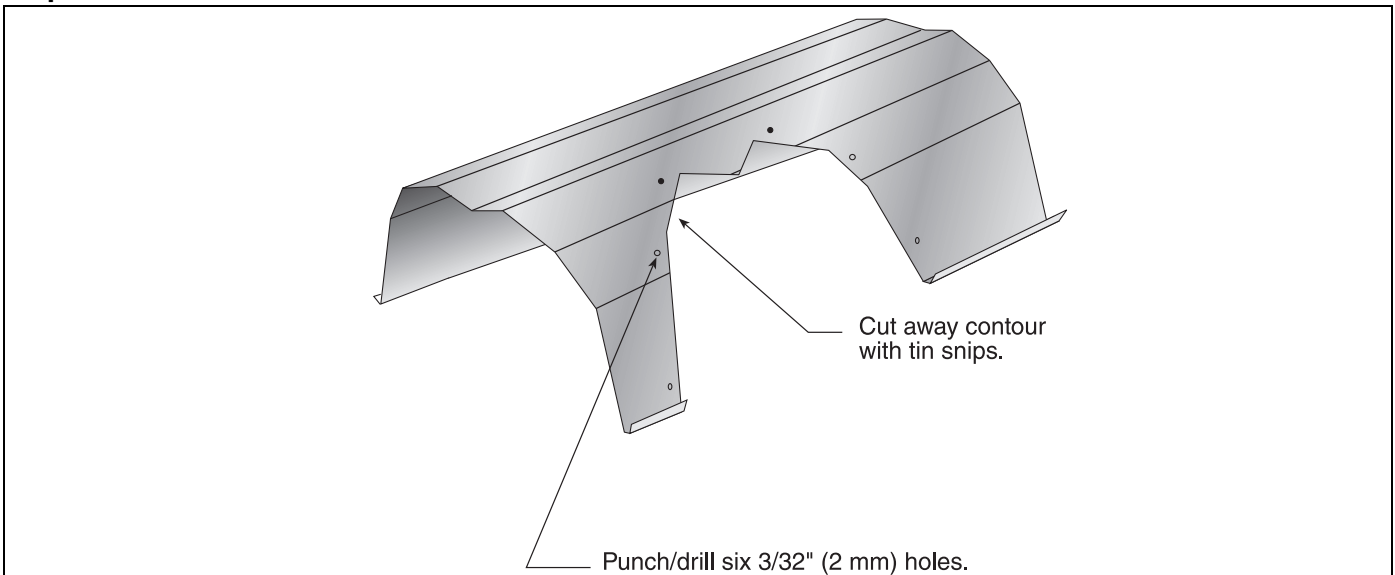

Step 7.2.5 Reflector Joint Detail

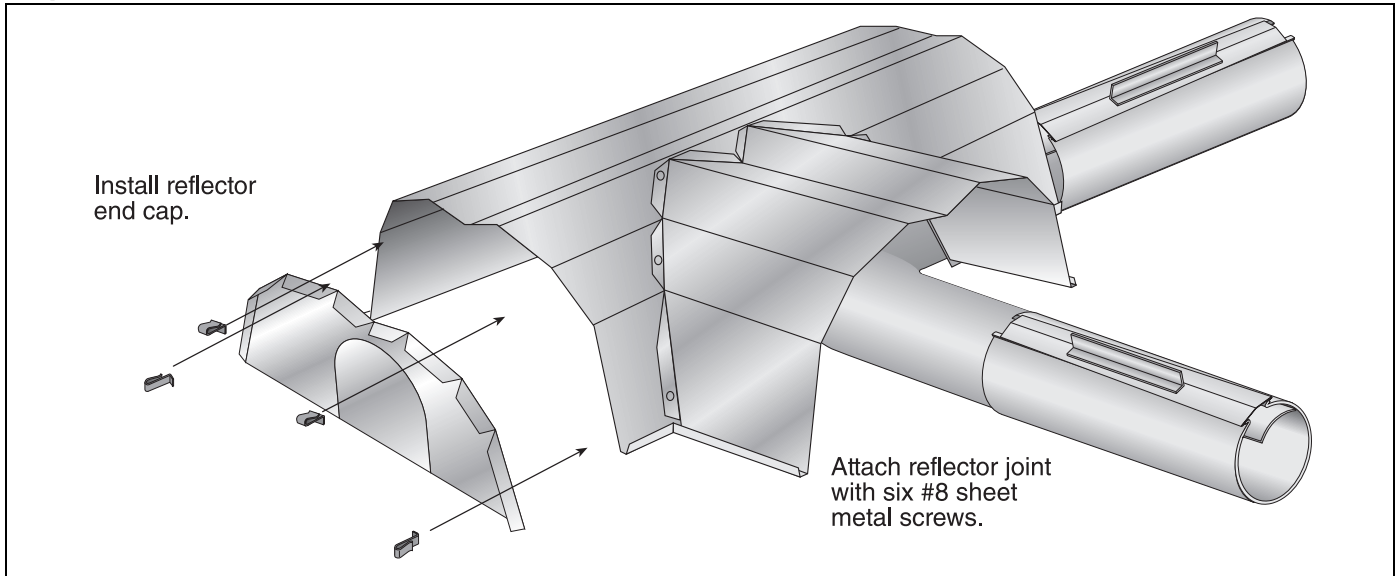
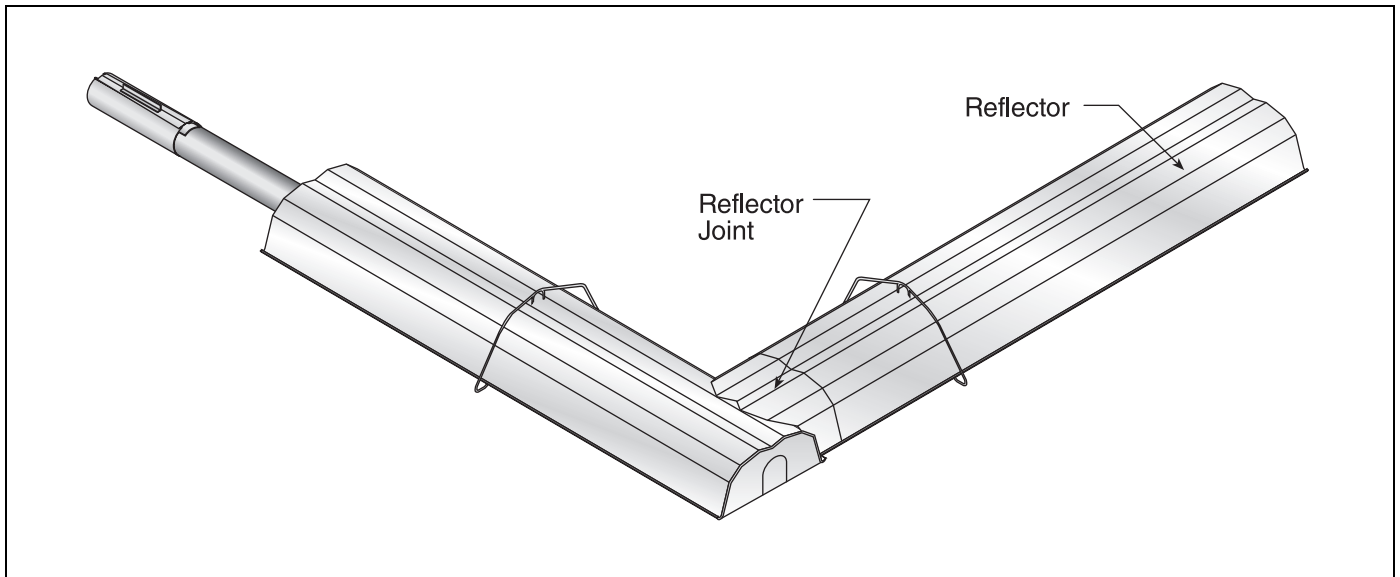
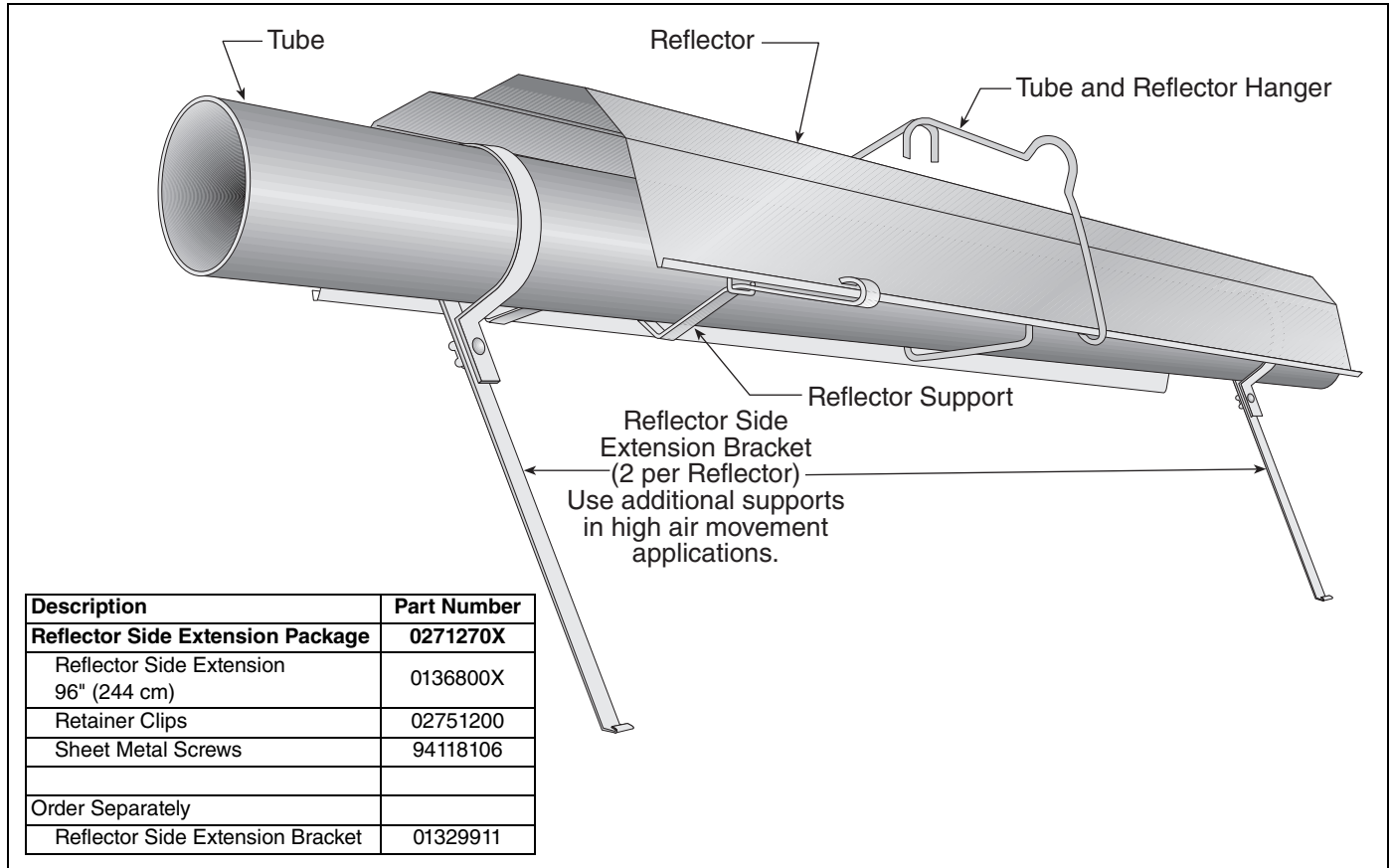

FIGURE 27: Reflector Joint Detail



7.3 Reflector Side Extension

Step 7.3.1 Bracket Installation



Step 7.3.2 Side Reflector Installation

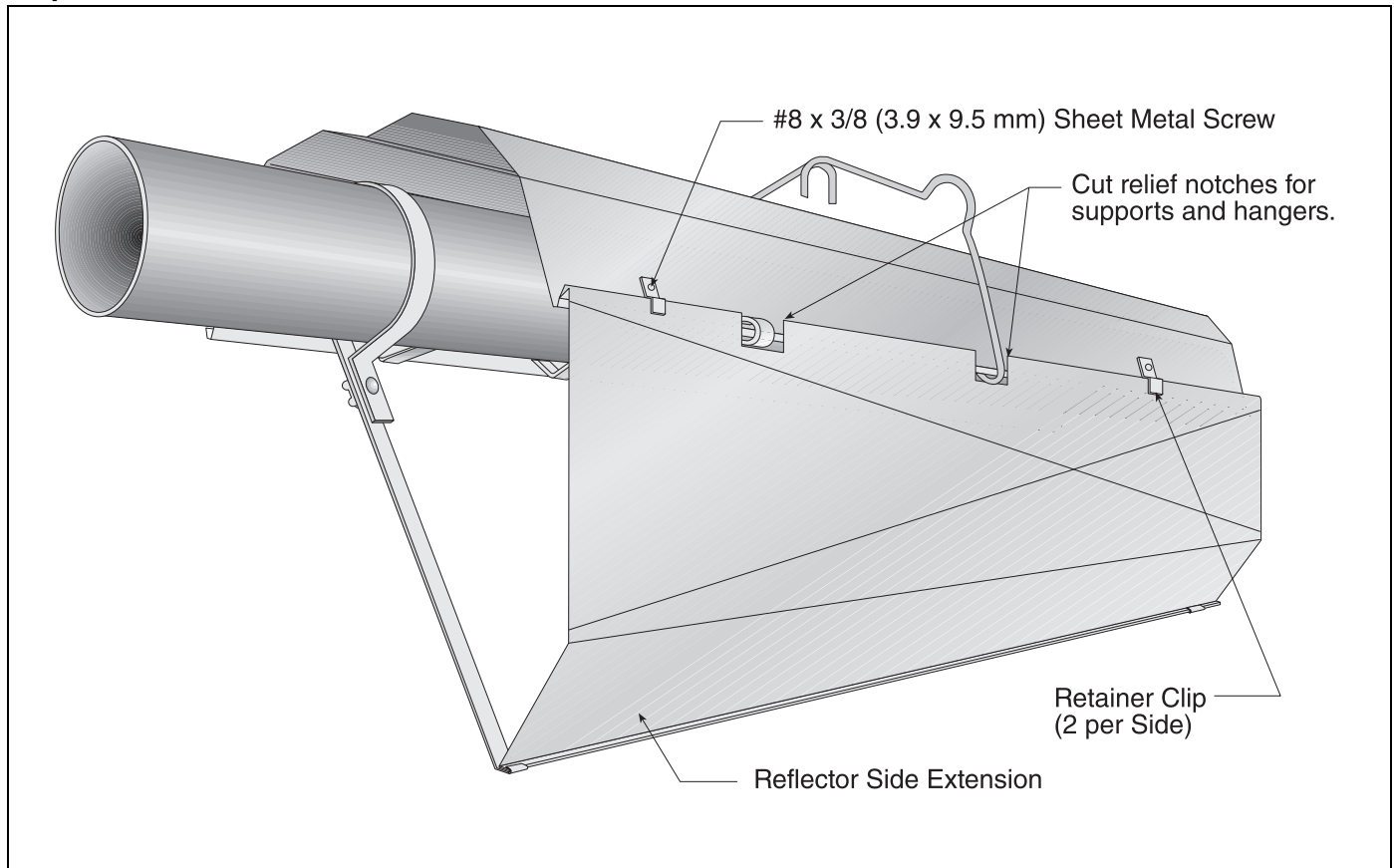

7.4 Lower Clearance Shield Installation

Step 7.4.1 Shield Support Strap Assembly

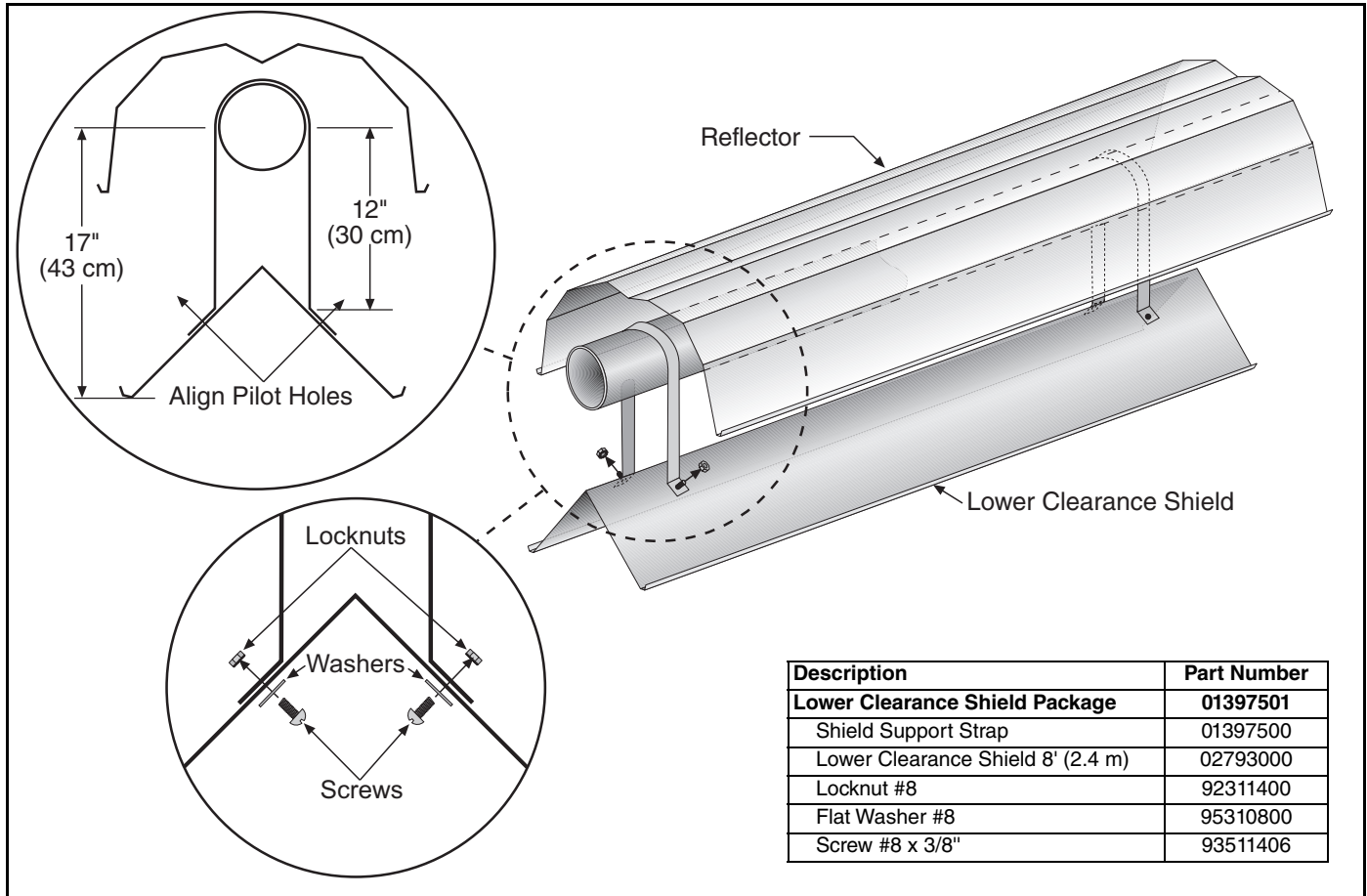

7.5 Two-Foot Decorative Grille Installation

Step 7.5.1 Grille Installation

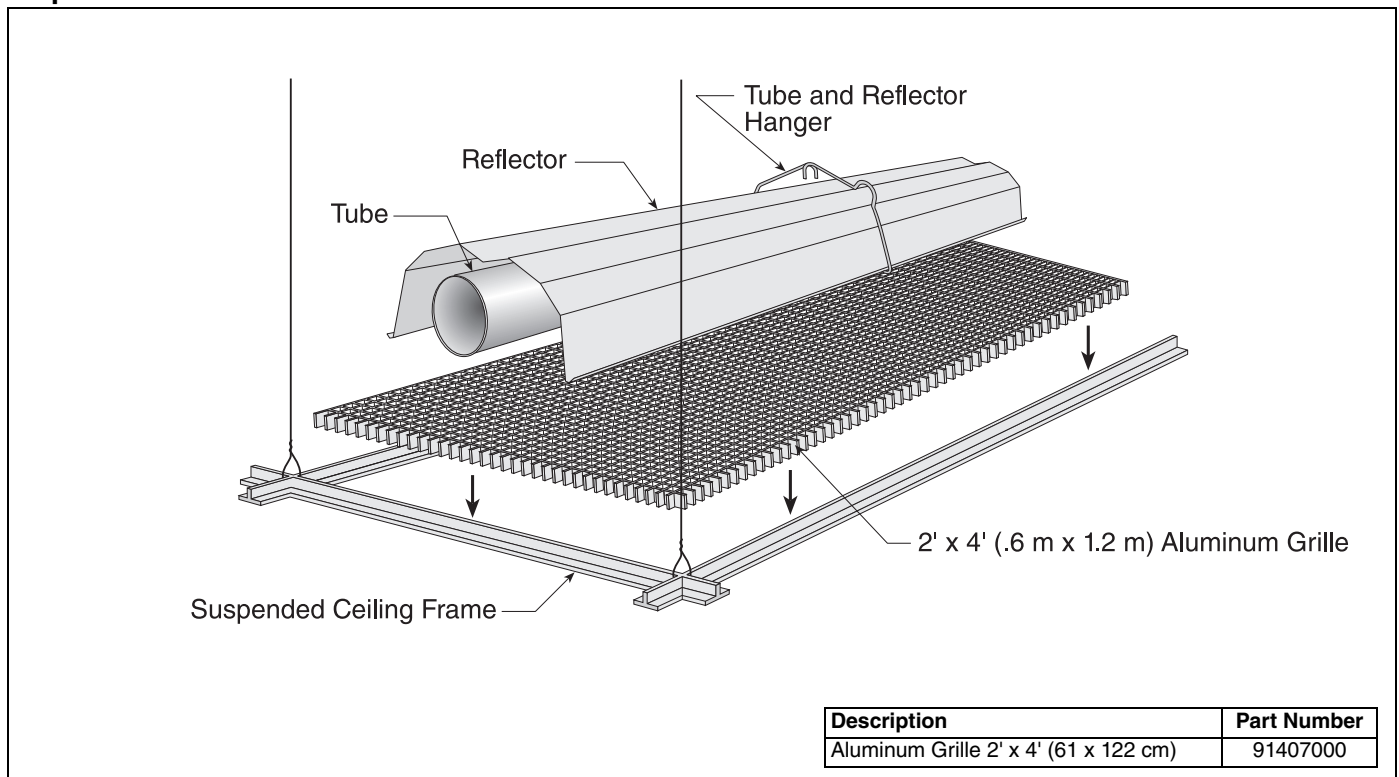

Step 7.5.2 Frame Shield Installation

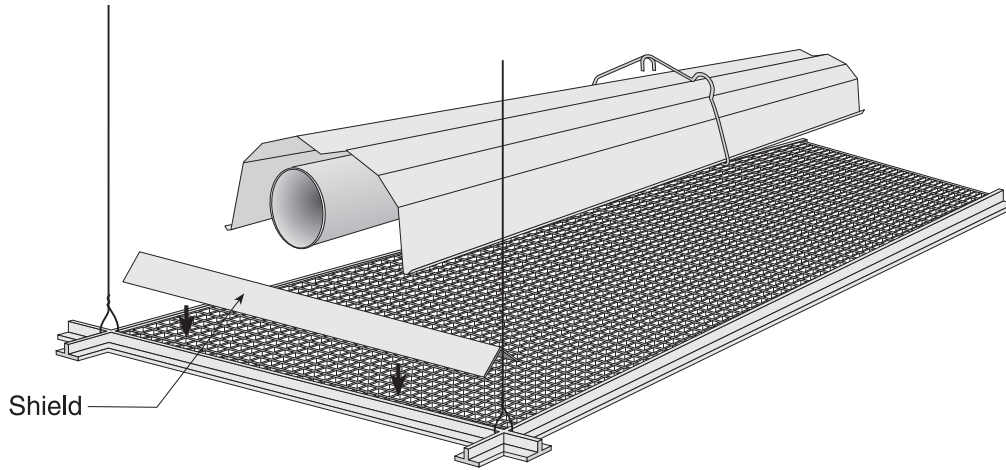

| Description | Part Number |
|--------------------------------|-------------|
| Deco Grille Shield 24" (61 cm) | 01365900 |

Step 7.5.3 Reflector Side Extension Installation for Decorative Grilles

NOTE: If the decorative grille system is to be installed in an area with considerable air movement, it is recommended that one #8 x 3/8" sheet metal screw be installed per reflector extension to prevent it from blowing over.

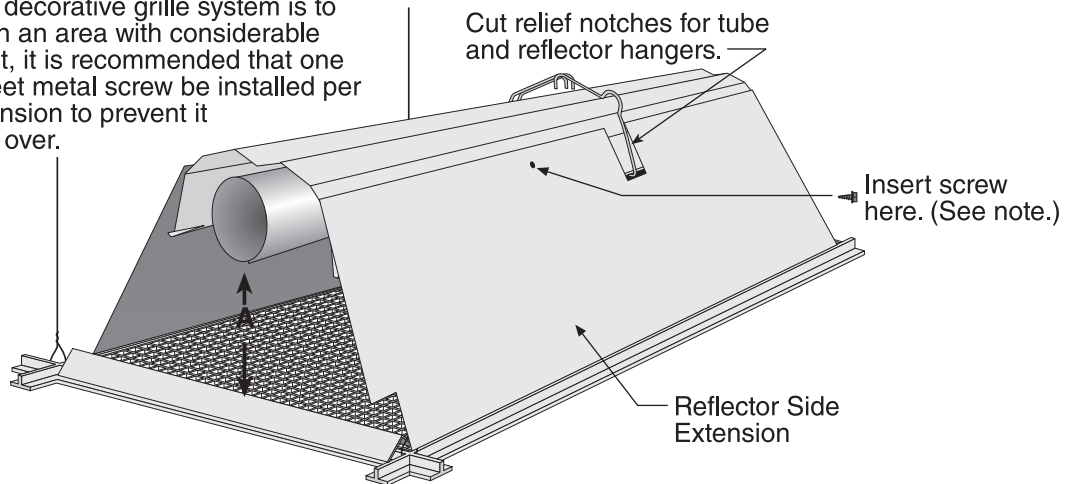

| Distance "A" | | Extension | |
|--------------|-------------|-----------|-------------|
| Minimum | Maximum | Part No. | Width |
| 2" (4 cm) | 6" (15 cm) | 013704XX | 8" (20 cm) |
| 6" (15 cm) | 10" (26 cm) | 013704XX | 12" (30 cm) |
| 10" (26 cm) | 14" (37 cm) | 013704XX | 16" (40 cm) |

| Description | Part Number |
|---------------------------------------|-------------|
| Reflector Side Extension 48" (122 cm) | 013704XX |

7.6 Protective Grille Installation

Step 7.6.1 Silicone Cap Installation

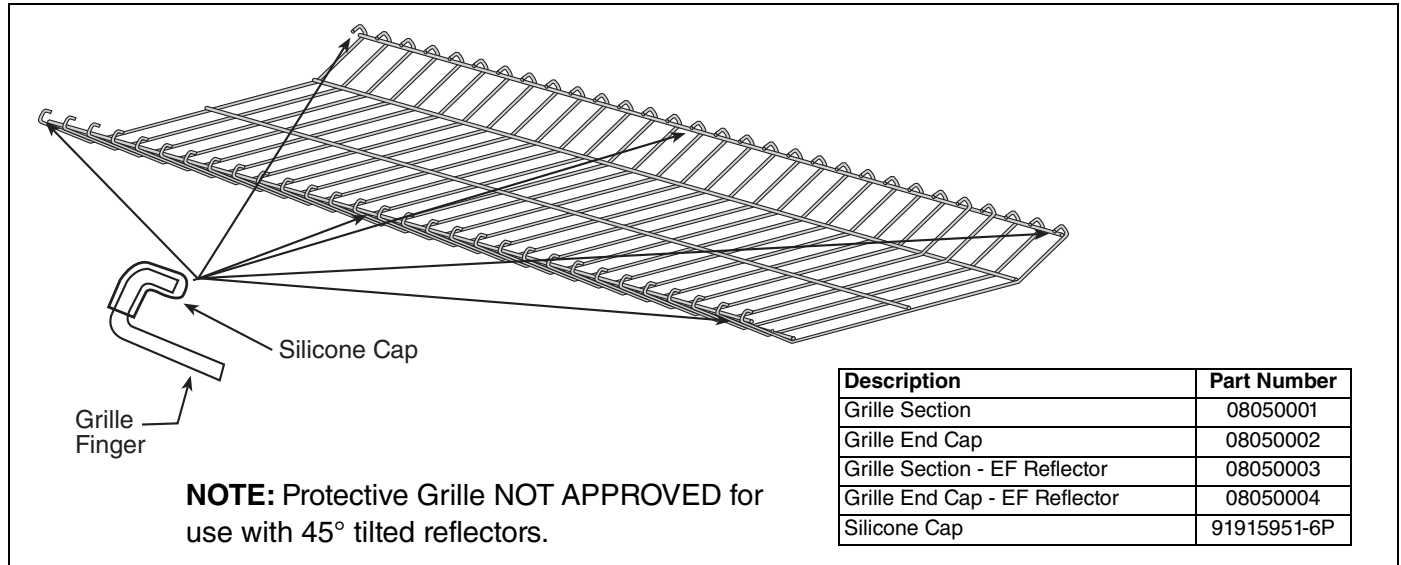

Step 7.6.2 Grille End Cap Installation

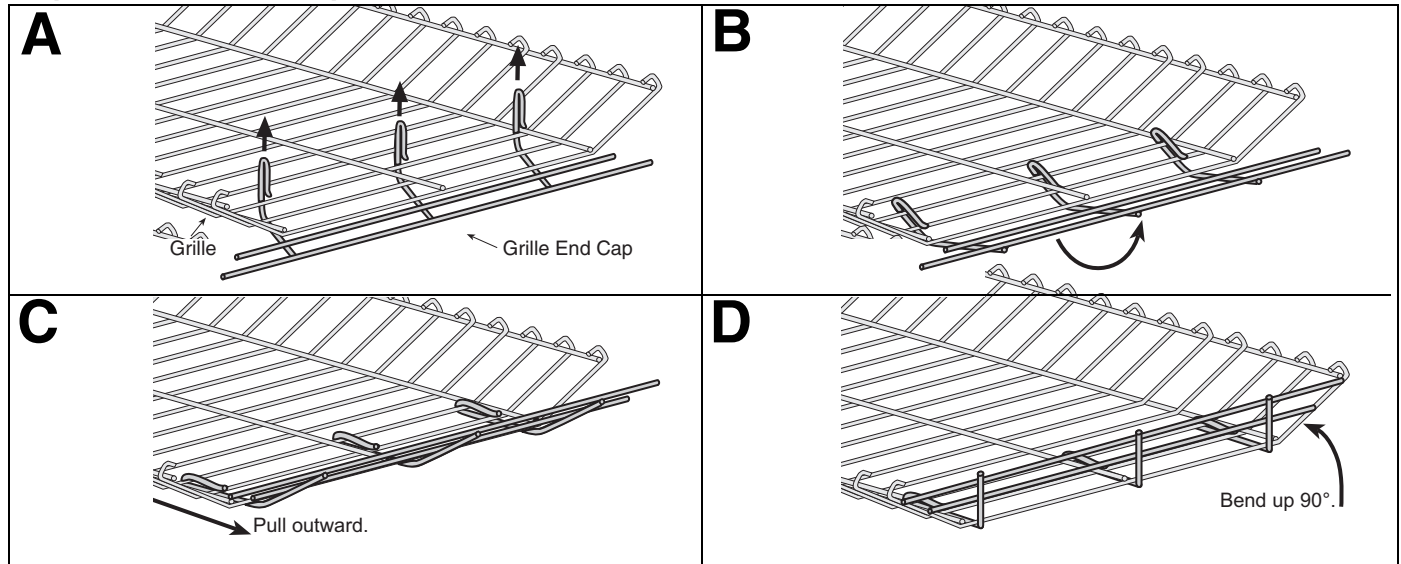

Step 7.6.3 Grille Installation

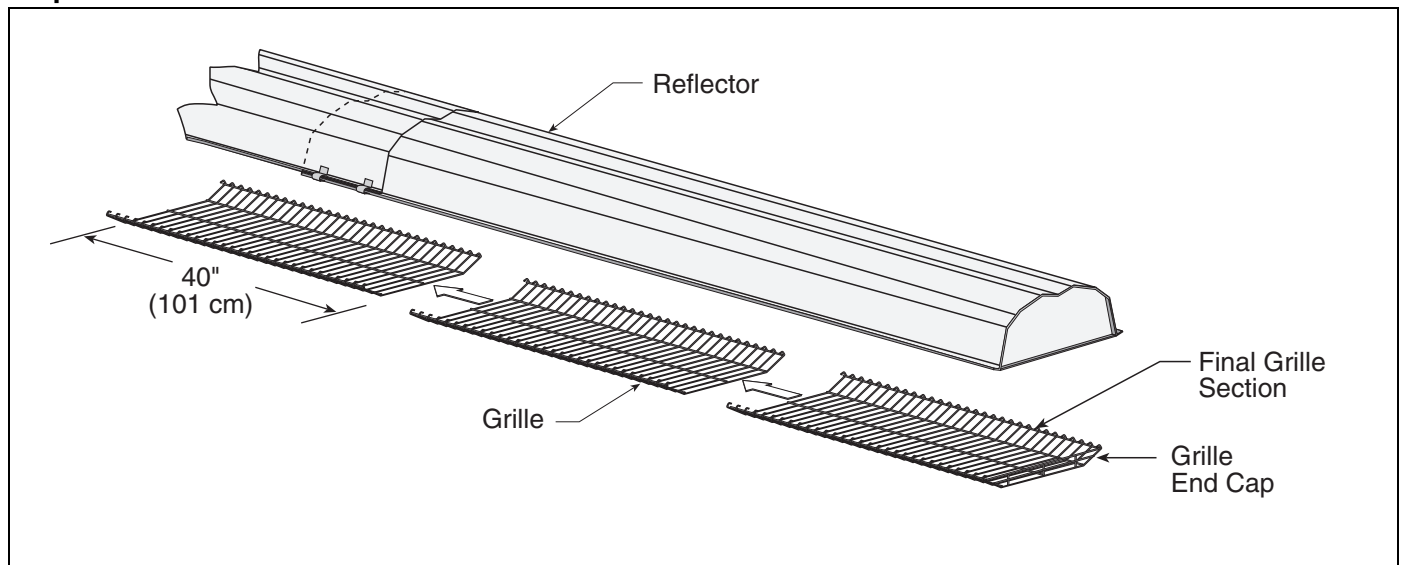

SECTION 8: VENTING

| |
|---|
| ⚠ WARNING |
|  |
| Carbon Monoxide Hazard |
| Heaters installed unvented must be interlocked with sufficient building exhaust. |
| Heaters must be installed according to the installation manual. |
| Failure to follow these instructions can result in death or injury. |

| |
|--|
| ⚠ WARNING |
|  |
| Cut/Pinch Hazard |
| Wear protective gear during installation, operation and service. |
| Edges are sharp. |
| Failure to follow these instructions can result in injury. |

8.1 Venting

This heater is considered a Category III vented appliance. The Serial plate on the heater will indicate vent Category and this manual will describe the installation requirements for vent Category.

This heater must be vented in accordance with the rules contained in this manual and with the following national codes and any state, provincial or local codes which may apply:

United States: Refer to National Fuel Gas Code NFPA 54/ANSI Z223.1 - latest revision.

Canada: Refer to Natural Gas and Propane Installation Code CSA B149.1 - latest revision.

Exhaust end of heater will accept a 4" (10 cm) vent pipe using the vent adapter (P/N 90502701). To

prevent leakage of condensation, install the vent adapter with the seam on top and seal the joint using a high temperature silicone sealant.

Any portion of vent pipe passing through a combustible wall must have an approved thimble to conform with the above listed codes.

Vent pipe must be sloped downward away from the heater 1/2" (1 cm) for every 20' (6 m).

The heater may be individually vented or common vented. When venting horizontally, a maximum of two heaters can be commonly vented. See Page 39, Section 8.10. When venting vertically, a maximum of four heaters can be commonly vented. See Page 47, Section 8.10.

The heater may also be installed unvented in certain circumstances according to building ventilation codes. Refer to the above codes and Page 43, Section 8.2 for further information. Unvented operation also requires compliance with the clearances to combustibles given on Page 9, Figure 12.

The bottom of the vent or air intake terminal shall not be located less than 1' (0.3 m) above grade level.

The vent shall not terminate less than 7' (2.1 m) above grade where located adjacent to public walkways.

Vent terminal must be installed at a height sufficient to prevent blockage by snow, and building materials protected from degradation by flue gases.

Secure all joints with #8 x 3/8 sheet metal screws. Seal all joints with high temperature silicone sealant.

Vent terminal must be beyond any combustible overhang.

8.1.1 United States Requirements

Vent must terminate at least 3' (0.9 m) above any forced air inlet located within 10' (3.1 m).

Vent must terminate at least 4' (1.2 m) below, 4' (1.2 m) horizontally from, or 1' (0.3 m) above any door, operable window, or gravity air inlet into any building.

8.1.2 Canadian Requirements

The vent shall not terminate within 6' (1.8 m) of a mechanical air supply inlet to any building.

The vent shall not terminate within 3' (0.9 m) of a window or door that can be opened in any building, any non-mechanical air supply inlet to any building, or of the combustion air inlet of any other appliance.

8.1.3 Vent Category Definitions

Radiant tube heaters are divided into four categories based on the static pressure produced in the vent and the percentage flue loss.

Category I – a radiant tube heater that operates with a non-positive vent static pressure and with a vent gas temperature that avoids excessive condensate production in the vent

Category II – a radiant tube heater that operates with a non-positive vent static pressure and with a vent gas temperature that can cause excessive condensate production in the vent

Category III - a radiant tube heater that operates with a positive vent static pressure and with a vent gas temperature that avoids excessive condensate production in the vent

Category IV - a radiant tube heater that operates with a positive vent static pressure and with a vent gas temperature that can cause excessive condensate production in the vent

This heater is considered a Category III vented appliance. The Serial plate on the heater will indicate vent Category and this manual will describe the installation requirements for vent Category.

8.2 Unvented Operation

Sufficient ventilation must be provided in the amount of 4 cfm per 1000 Btu/h firing rate (United States); 3 cfm per 1000 Btu/h firing rate (Canada).

Use of optional outside combustion air is not recommended with unvented heaters.

If exhaust fans are used to supply ventilation air, an interlock switch must be used to prevent the heater from coming on when the fans are off. This may be done using a pressure switch.

8.3 Horizontal Venting (Category III)

All horizontal venting configurations for this product are considered Category III.

In noncombustible walls only, vent terminal (P/N 02537801-1P) may be used.

For 4" (10 cm) vents in either combustible or noncombustible walls, use Tjernlund VH1-4 (P/N

90502100) or equivalent, insulated vent terminal. Follow the manufacturer's instructions for proper installation.

For 6" (15 cm) common vents in either combustible or noncombustible walls, use Tjernlund VH1-6 (P/N 90502101) or equivalent, insulated vent terminal.

Approved venting material for horizontal venting (Category III) must be single-wall corrosion resistant with a thickness of no less than 26 gauge. It is required that all vent pipes and connectors be fastened together with sheet metal screws and sealed with high temperature silicone sealant approved for at least 550 °F (288 °C) (supplied by others). The installer must perform a leak test on the complete venting system. A solution of soap and water should be used to test the venting system.

A continuous section of type B-vent may only be used to pass through the outside wall or outside of the building. Horizontal venting (Category III) does not allow the use of type B-vent inside of the space.

Follow the vent material manufacturer's instructions for proper installation.

8.4 Vertical Venting (Category III)

For 4" (10 cm) common or single heater vent, an approved vent cap (P/N 90502300) must be used.

For 6" (15 cm) common vent, an approved vent cap (P/N 90502302) must be used.

Approved venting material for vertical venting (Category III) must be single-wall corrosion resistant with a thickness of no less than 26 gauge. It is required that all vent pipes and connectors be fastened together with sheet metal screws and sealed with high temperature silicone sealant approved for at least 550 °F (288 °C) (supplied by others). The installer must perform a leak test on the complete venting system. A solution of soap and water should be used to test the venting system.

A continuous section of type B-vent may only be used to pass through the roof or outside of the building. Vertical venting (Category III) does not allow the use of type B-vent inside of the space.

For common vertical venting of more than two heaters, See *Page 42, Section 8*.

A vent shall not extend less than 2' (0.6m) above the highest point where it passes through a flat roof of a building.

Note: Vertical venting will be classified as a Category III if the length of the horizontal portion of the vent pipe is greater than 75% of the vertical portion of the vent pipe. (Example: If vertical vent section of the vent is 10' (3 m) long, the horizontal section of the vent is greater than 7' 6" (2.3 m) long.)

8.5 Unvented Operation Tube Termination

Turndown type vent terminal with a screen must be installed at the exhaust end of the tube. Vent terminal design shall not incorporate backdraft flap.

FIGURE 28: Tube Termination

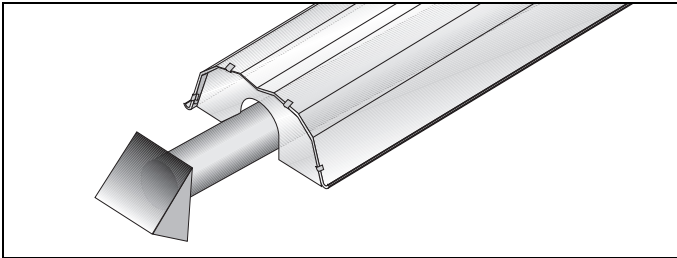

8.6 Length Requirements

The maximum vent length allowed is 45' (13.7 m).
The maximum outside air supply duct length allowed is 45' (13.7 m).

The total vent length, plus outside air duct length, plus any extensions to minimum heat exchanger lengths, cannot exceed 65' (19.8 m).

Vent length should be limited to less than 20' (6 m). If using vent lengths greater than 20' (6 m), condensation will form in the vent pipe. Insulation and additional sealing measures (high temperature silicone at all seams) are required. Optional heat exchanger beyond minimum lengths is considered as vent length for length determination.

Subtract 15' (4.6 m) of maximum allowed vent or duct length per vent elbow if more than two are used.

8.7 Vent Material Recommendations

Vent recommendations:

1. Porcelain coated tubing 4" (10 cm) O.D. (P/N 9141030D)
2. Heat treated aluminized tubing 4" (10 cm) O.D. (P/N 91409408)
- Heat treated aluminized tubing 6" (15 cm) O.D. (P/N E0009105)

3. Single wall pipe (Type-C) that is corrosion resistant galvanized steel - minimum 26 ga. (Supplied by others)

4. Double wall vent (Type-B). Used ONLY as a continuous section passing through the outside wall, roof or outside of the building.

NOTE: 4" (10 cm) O.D. Porcelain coated tubing (P/N 9141030D), 4" (10 cm) O.D. Heat treated aluminized tubing (P/N 91409408), and 6" (15 cm) O.D. Heat treated aluminized tubing (P/N E0009105) are equivalent to single wall flue pipe.

8.8 Horizontal Venting (Category III) 4" (10 cm) Pipe

Note: A continuous section of type B-vent may only be used to pass through the outside wall or outside of the building. Horizontal venting (Category III) does not allow the use of type B-vent inside of the space.

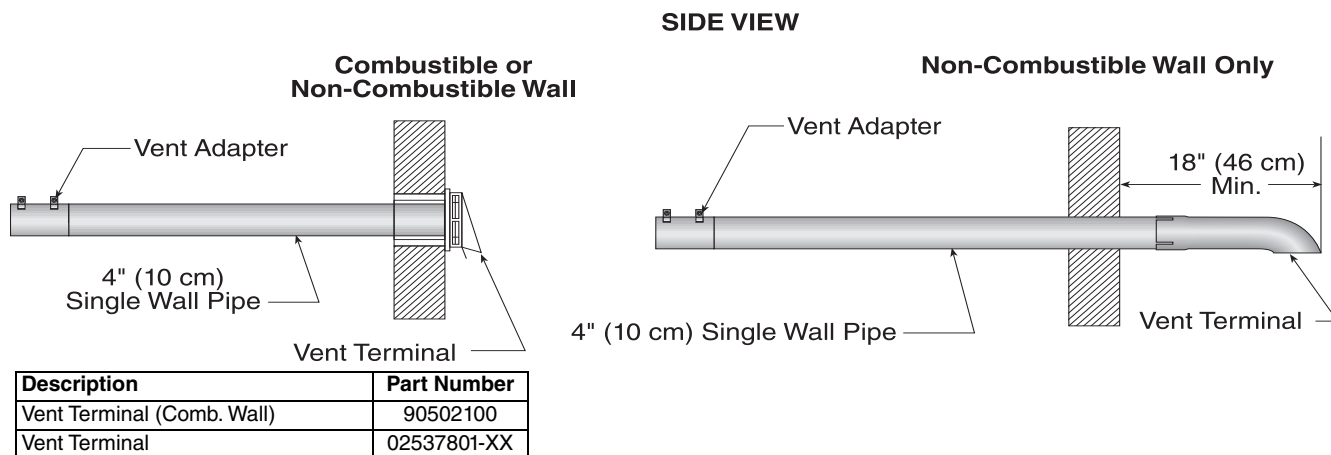

Vertical Venting (Category III) 4" (10 cm) Pipe

Note: A continuous section of type B-vent may only be used to pass through the roof or outside of the building. Vertical venting (Category III) does not allow the use of type B-vent inside of the space.

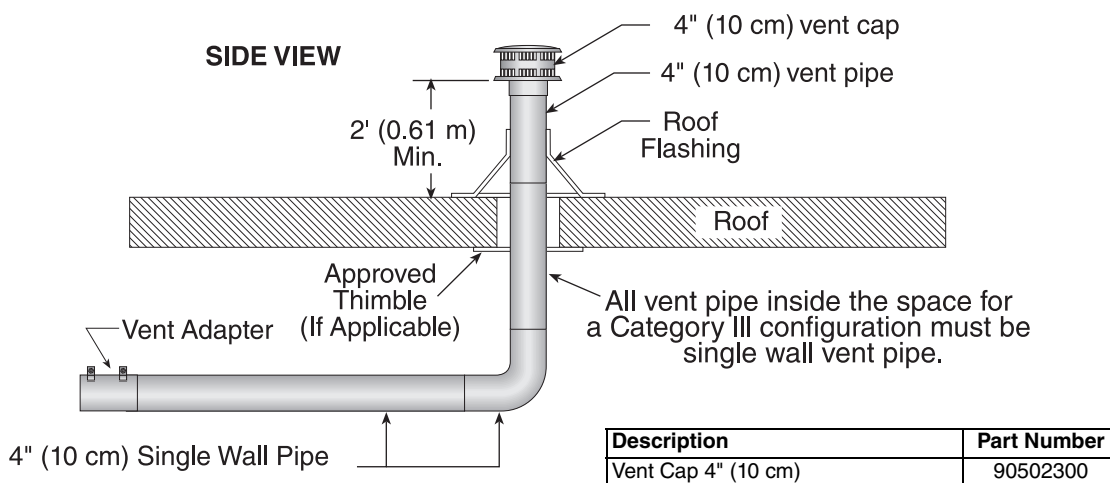

NOTE:

It is required that all vent pipes and connectors be fastened together with sheet metal screws and sealed with high temperature silicone sealant approved for at least 550 °F (288 °C) (supplied by others). The installer must perform a leak test on the complete venting system. A solution of soap and water should be used to test the venting system.

8.9 Common Side Wall Horizontal Venting (Category III)

Note: A continuous section of type B-vent may only be used to pass through the outside wall or outside of the building. Horizontal venting (Category III) does not allow the use of type B-vent inside of the space.

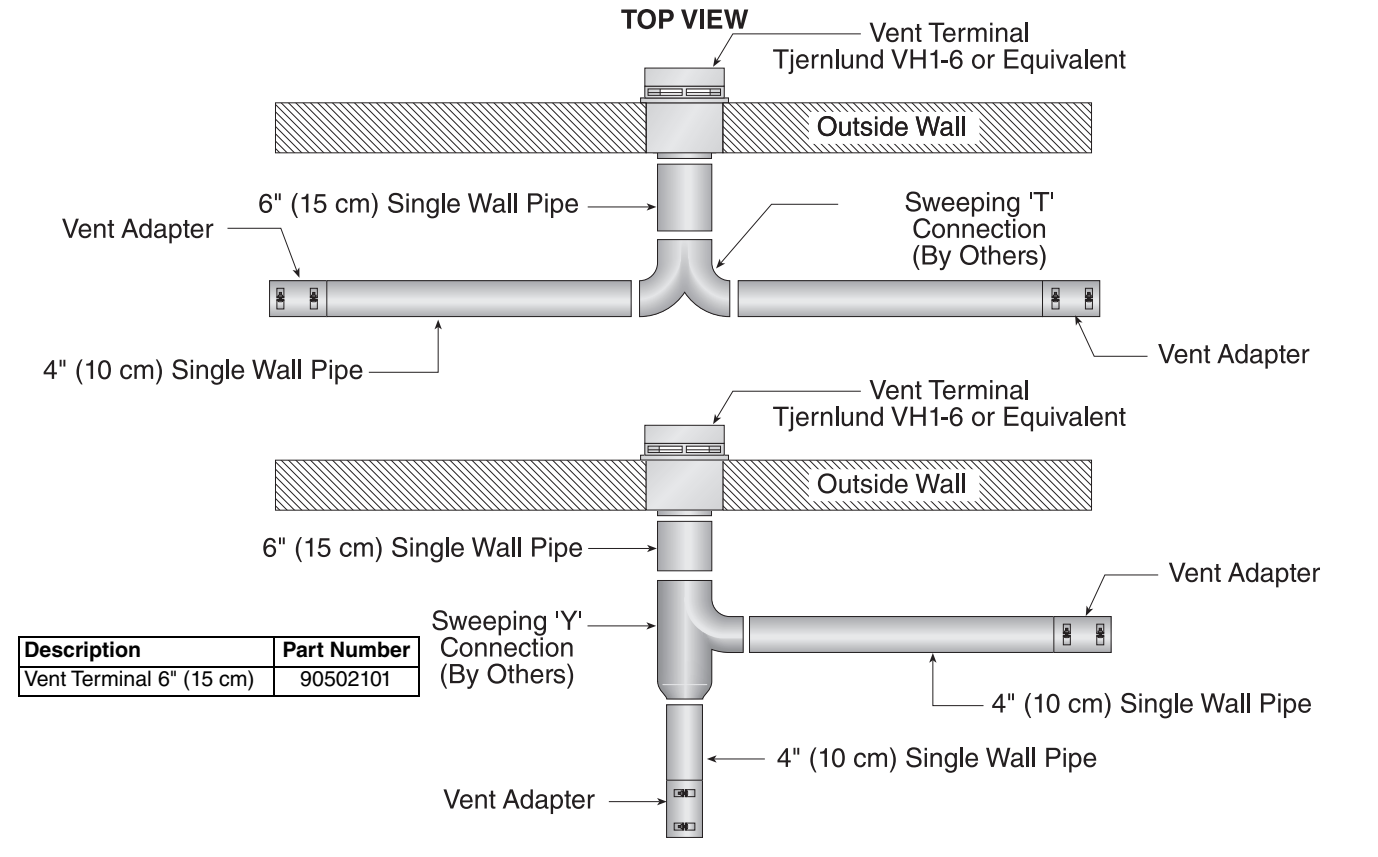

Requirements:

- Maximum of two heaters can be commonly vented through a side wall.
- Heaters must be of the same BTU output.
- Heaters must be controlled by a common thermostat.

NOTE:

It is required that all vent pipes and connectors be fastened together with sheet metal screws and sealed with high temperature silicone sealant approved for at least 550 °F (288 °C) (supplied by others).

The installer must perform a leak test on the complete venting system. A solution of soap and water should be used to test the venting system.

8.10 Common Vertical Venting (Category III)

Note: A continuous section of type B-vent may only be used to pass through the roof or outside of the building. Vertical venting (Category III) does not allow the use of type B-vent inside of the space.

SIDE VIEW

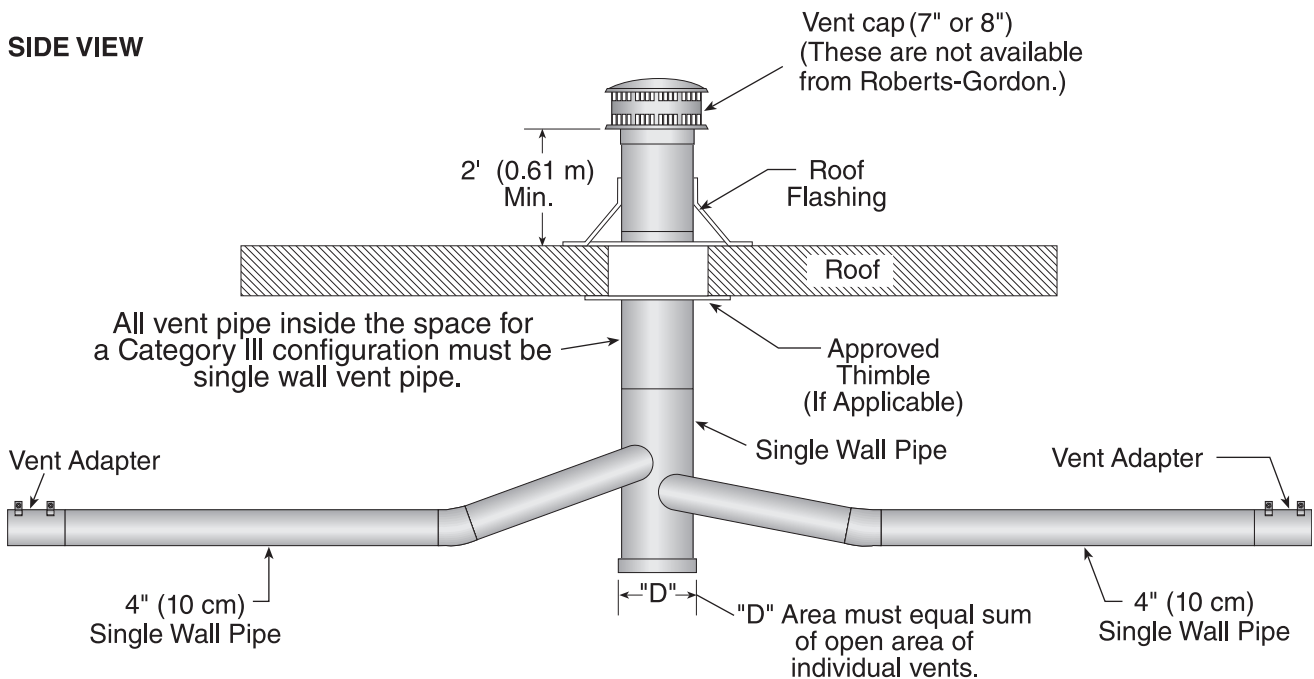

TOP VIEW

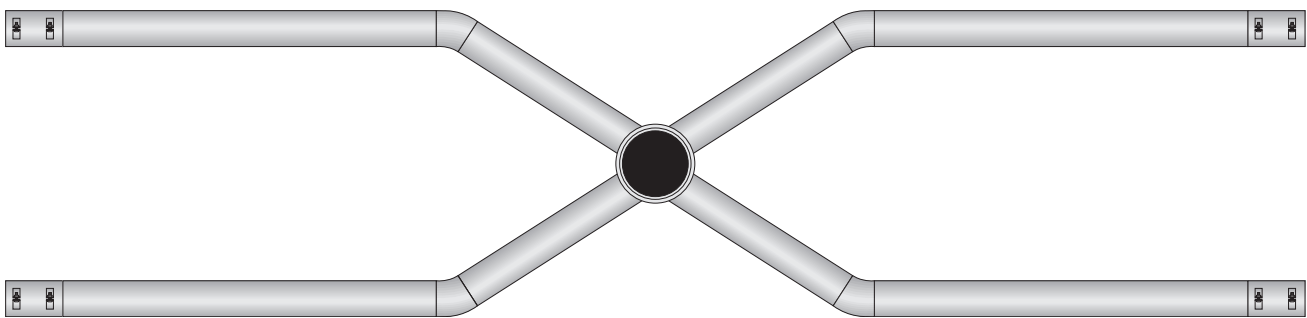

Requirements:

- Maximum of four heaters can be commonly vented through the roof.
- Heaters must be of the same BTU output.
- Heaters must be controlled by a common thermostat.
- Connections to a common stack must be positioned to avoid direct opposition between streams of combustion gases.

NOTE:

It is required that all vent pipes and connectors be fastened together with sheet metal screws and sealed with high temperature silicone sealant approved for at least 550 °F (288 °C) (supplied by others). The installer must perform a leak test on the complete venting system. A solution of soap and water should be used to test the venting system.

8.11 Outside Combustion Air Supply

IMPORTANT: If the building has a slight negative pressure or corrosive contaminants, such as halogenated hydrocarbons, are present in the air, an outside combustion air supply to the heater is required. Seal all combustion air pipe joints.

Use of optional outside combustion air is not recommended with unvented heaters.

The air supply duct may have to be insulated to prevent condensation on the outer surface. The outside air terminal must not be more than 1' (31 cm) above the vent termination while maintaining a minimum distance of 3' (93 cm) for both vertical and horizontal venting.

8.11.1 Length Requirements

Follow the constraints listed on *Page 44, Section 8.6.*

8.11.2 Vertical Outside Air Supply for Single Heater Installation

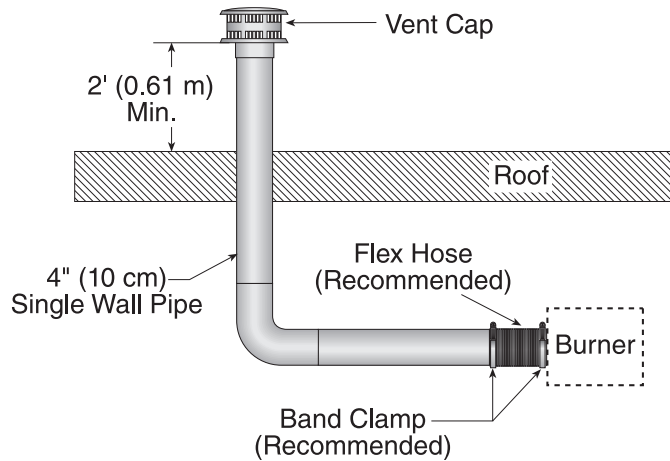

| Description | Part Number |
|---------------------|-------------|
| Vent Cap 4" (10 cm) | 90502300 |

8.11.3 Horizontal Outside Air Supply for Single Heater Installation

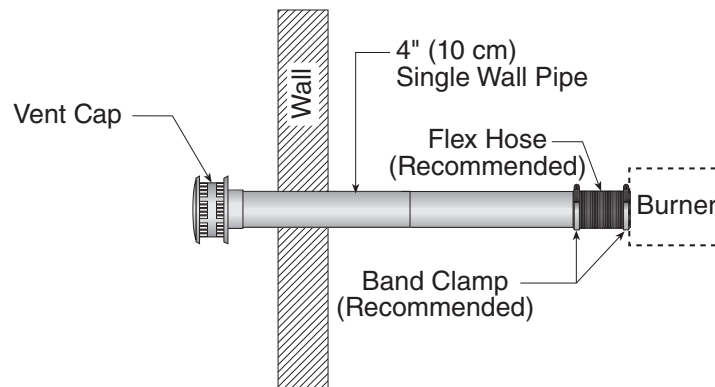

| Description | Part Number |
|---------------------|-------------|
| Vent Cap 4" (10 cm) | 90502300 |

8.11.4 Vertical Outside Air Supply for Double Heater Installation

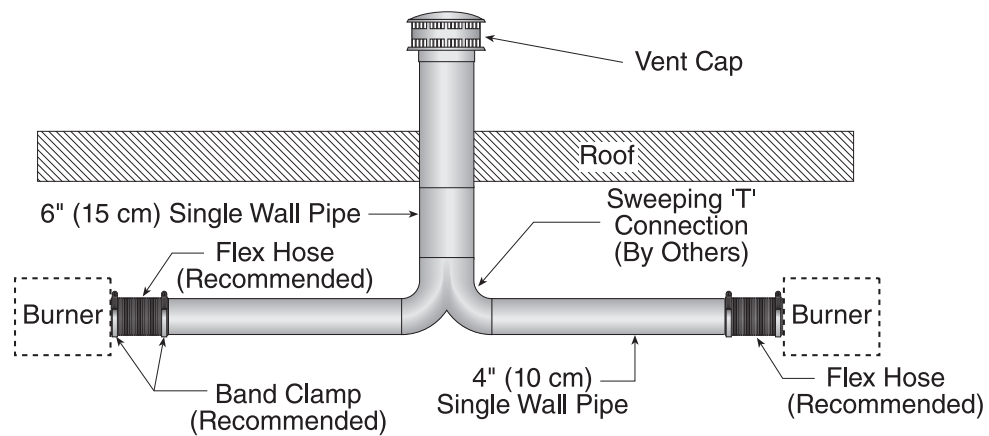

| Description | Part Number |
|---------------------|-------------|
| Vent Cap 6" (15 cm) | 90502302 |

Requirements:

- Heaters must be controlled by a common thermostat.

8.11.5 Horizontal Outside Air Supply for Double Heater Installation

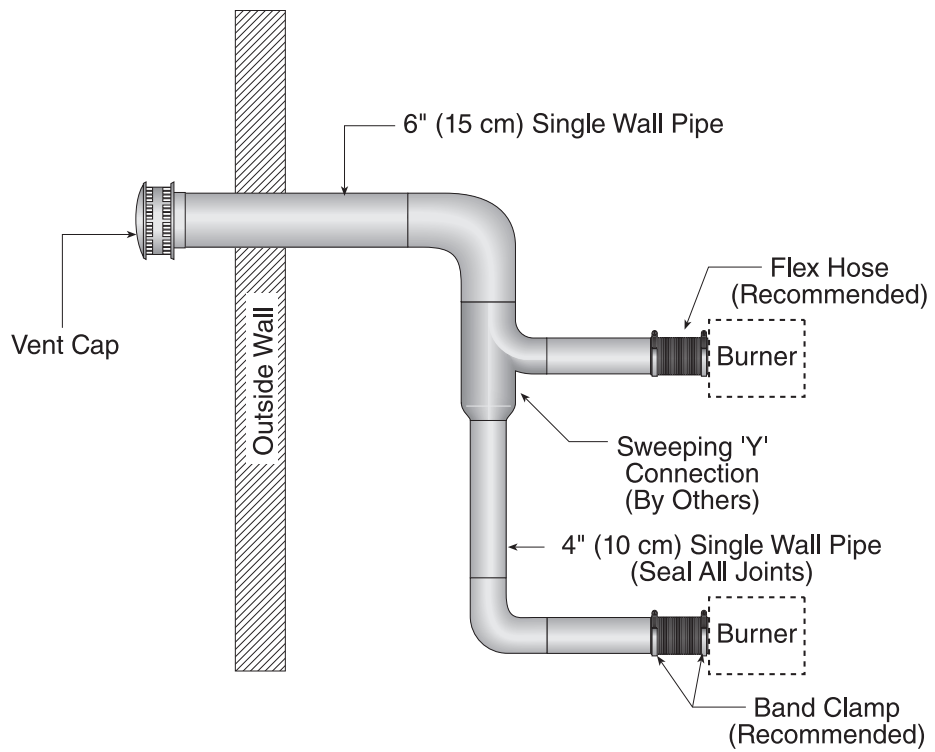

| Description | Part Number |
|---------------------|-------------|
| Vent Cap 6" (15 cm) | 90502302 |

Requirements:

- Heaters must be controlled by a common thermostat.

SECTION 9: GAS PIPING

! WARNING**Fire Hazard**

Tighten gas hose fittings to connect gas supply according to Figure 23.

Gas hose can crack when twisted.

Gas hose moves during normal operation.

Use only 36" (91 cm) long connector of 1/2" or 3/4" nominal ID.

Connector supplied with heater for U.S. models (not with Canadian models).

Failure to follow these instructions can result in death, injury or property damage.

! WARNING**Explosion Hazard**

Leak test all components of gas piping before operation.

Gas can leak if piping is not installed properly.

Do not high pressure test gas piping with heater connected.

Failure to follow these instructions can result in death, injury or property damage.

Install the gas hose as shown on *Page 52, Figure 29*. The gas hose accommodates expansion of the heating system and allows for easy installation and service of the burner. Before connecting the burners to the supply system, verify that all high pressure testing of the gas piping has been completed. There is an expansion of the tube with each firing cycle; this will cause the burner to move with respect to the gas hose. This can cause a gas leak resulting in an unsafe condition if the gas connection is not made strictly in accordance with *Figure 29 on Page 52*.

Meter and service must be large enough to handle all the burners being installed plus any other connected load. The gas hose which feeds the system must be large enough to supply the required gas with a maximum pressure drop of 1/2" w.c. When gas piping is not included in the layout drawing, the local gas supplier will usually help in planning the gas piping.

Gas lines must meet applicable codes:

United States: The Flexible Stainless Steel Gas Hose (US models) supplied with the heater is certified per the Standard for Connectors for Gas Appliances, ANSI Z21.24/CSA 6.10 - latest revision.

Canada: The Rubber Type 1 Gas Hose (Canadian models) optional with the heater is certified as being in compliance with the Standard for Elastomeric Composite Hose and Hose Couplings for Conducting Propane and Natural Gas, CAN/CGA 8.1 - Latest revision.

- **Check the pipe and tubing ends for leaks before placing heating equipment into service. When checking for gas leaks, use a soap and water solution; never use an open flame.**

FIGURE 29: Gas Connection with Flexible Gas Hose

CORRECT POSITIONS

Shut-Off Valve (included with gas hose) must be parallel to burner gas inlet. The 3" (8 cm) displacement shown is for the cold condition. This displacement may reduce when the system is fired.

High Gas Pressure Regulator to be installed upstream of flexible gas hose if inlet pressure exceeds maximum allowance. See Page 67, Section 14

⚠ CAUTION

Product Damage Hazard

Hold gas nipple securely with pipe wrench when attaching gas hose.

Failure to follow these instructions can result in product damage.

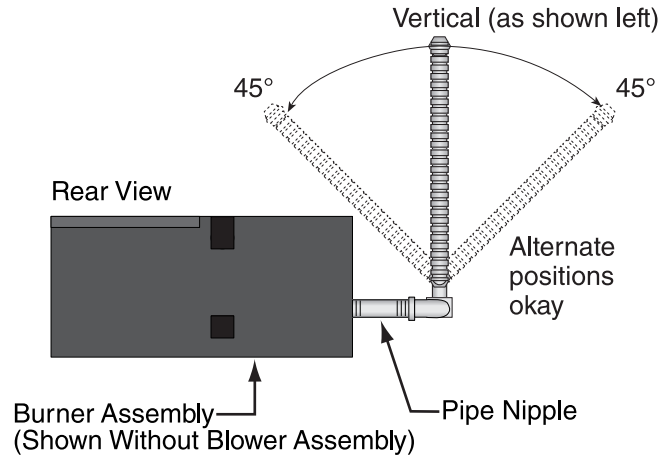
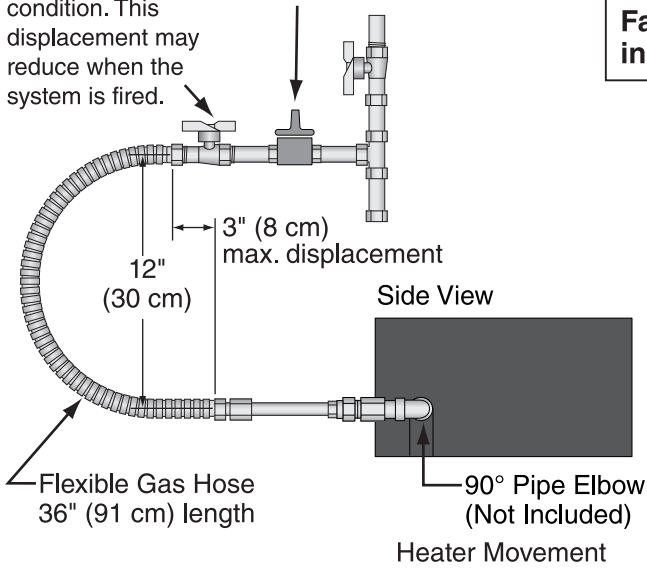

| Description | Part Number |
|--|-------------|
| High gas pressure regulator 1/2" – 2 PSI | 90207600 |
| High gas pressure regulator 3/4" – 5 PSI | 90207602 |

INCORRECT POSITIONS (WRONG INSTALLATION)

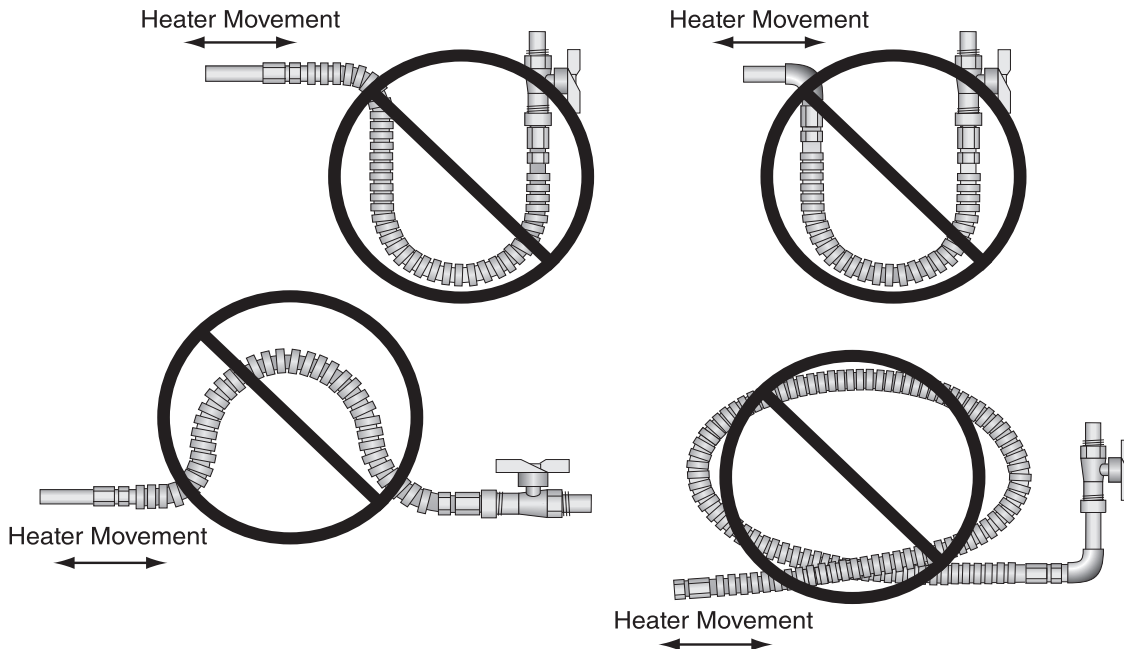

| Description | Part Number |
|--|-------------|
| 1/2" Flexible Stainless Steel Gas Hose (US Models) | 91412200 |
| 3/4" Flexible Stainless Steel Gas Hose (US Models) | 91412203 |
| 1/2" Rubber Type 1 Gas Hose (Canadian Models) | 91412206 |
| 3/4" Rubber Type 1 Gas Hose (Canadian Models) | 91412207 |

SECTION 10: WIRING

⚠ DANGER**Electrical Shock Hazard****Disconnect electric before service.****Heater must be properly earthed.****Failure to follow these instructions can result in death or electrical shock.**

Note # 6: The DF-Series heater is a dual firing heating unit and must be connected to a low voltage, two-stage thermostat for correct operation. A thermostat connector is provided on the exterior of the burner box. A separate external connection is also provided to energize a two-state low voltage thermostat for convenience. See Section 10.1 for wiring a two-stage thermostat to the burner box. For wiring a single two-stage thermostat to multiple burners, see *Page 54, Section 10.2*.

Heaters must be grounded in accordance with applicable codes: United States: Refer to National Electric Code® NFPA 70- latest revision; Canada: Refer to Canadian Electrical Code CSA C22.1 Part 1 - Latest revision.

If any of the original internal wiring must be replaced, it must be replaced with wiring materials have a temperature rating of at least 221°F (105°C) and 600 volts.

10.1 Dual Stage Low Voltage Thermostat Wiring

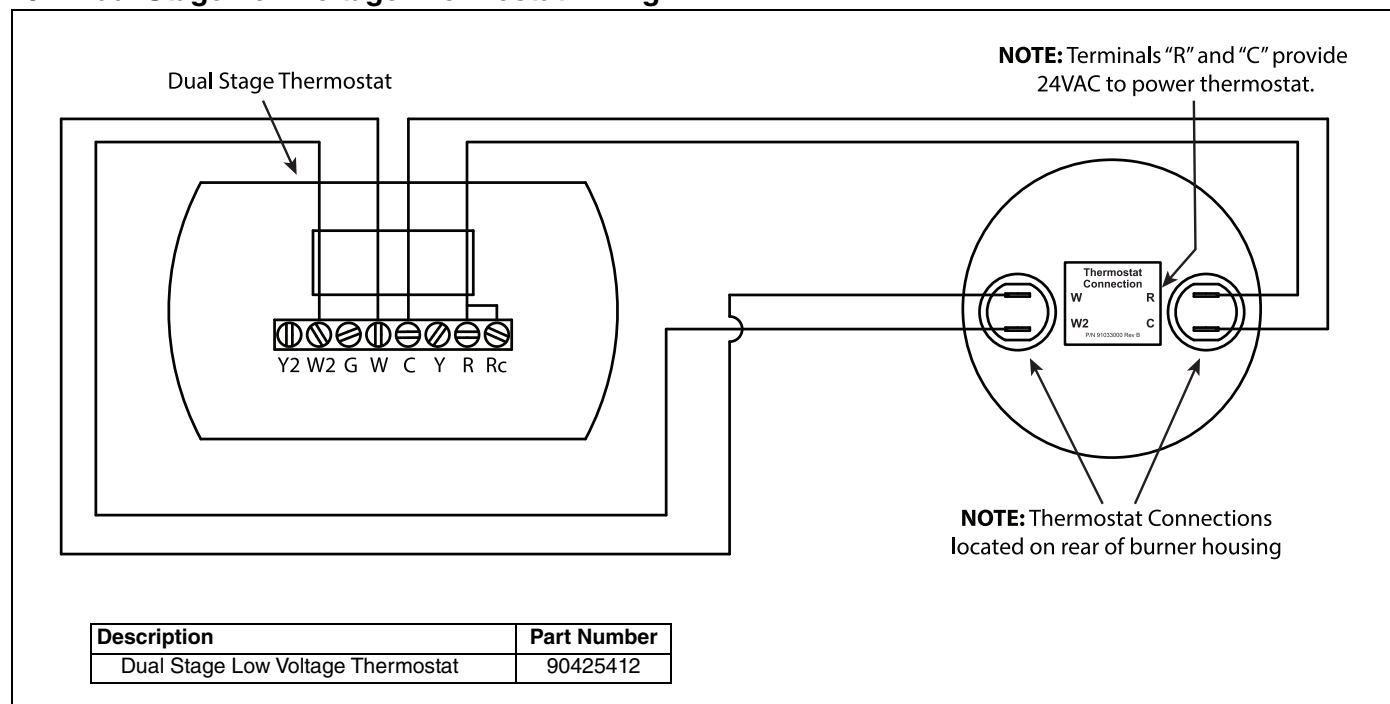

10.2 Multiple Burners For Connection To One Thermostat

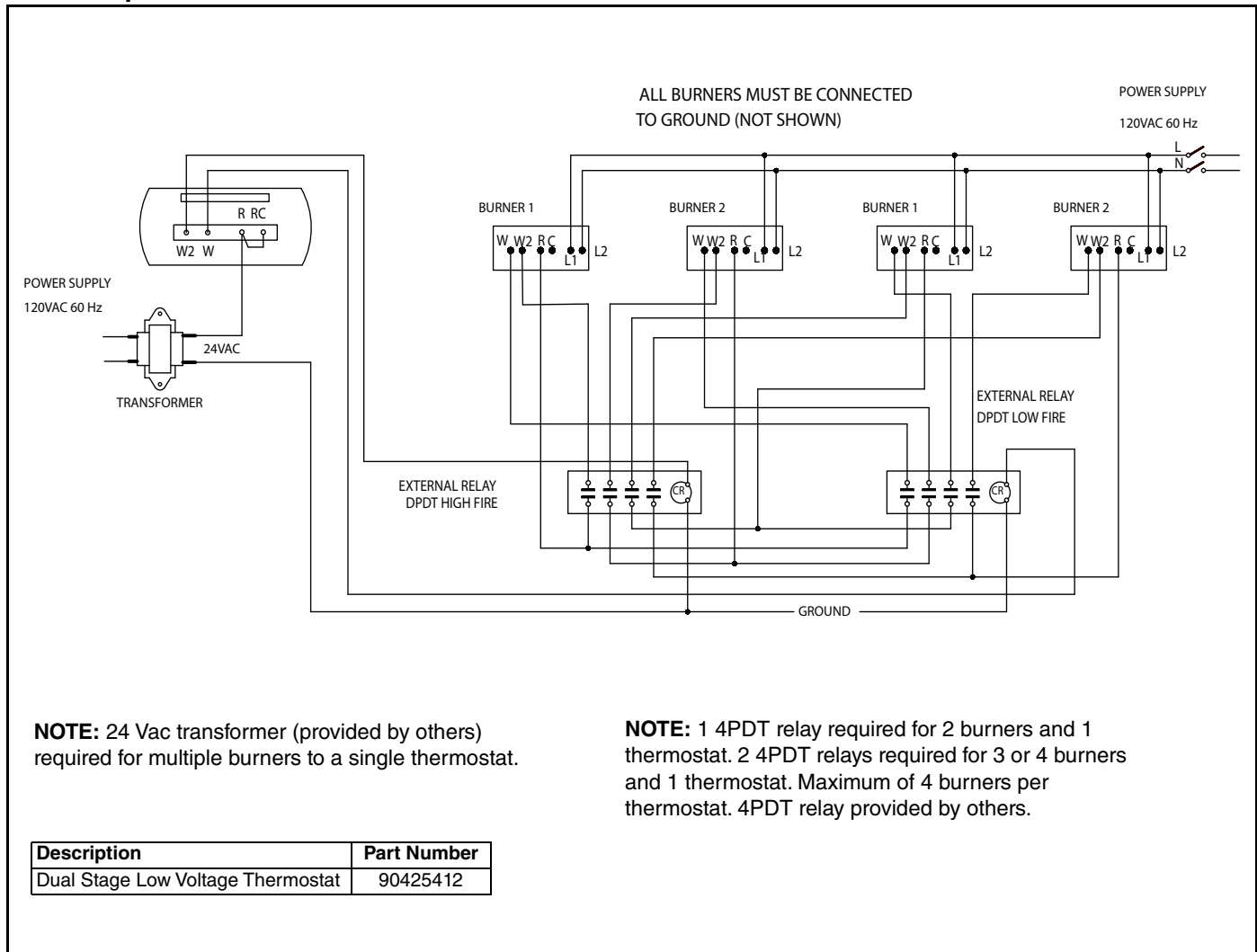

10.3 Internal Wiring

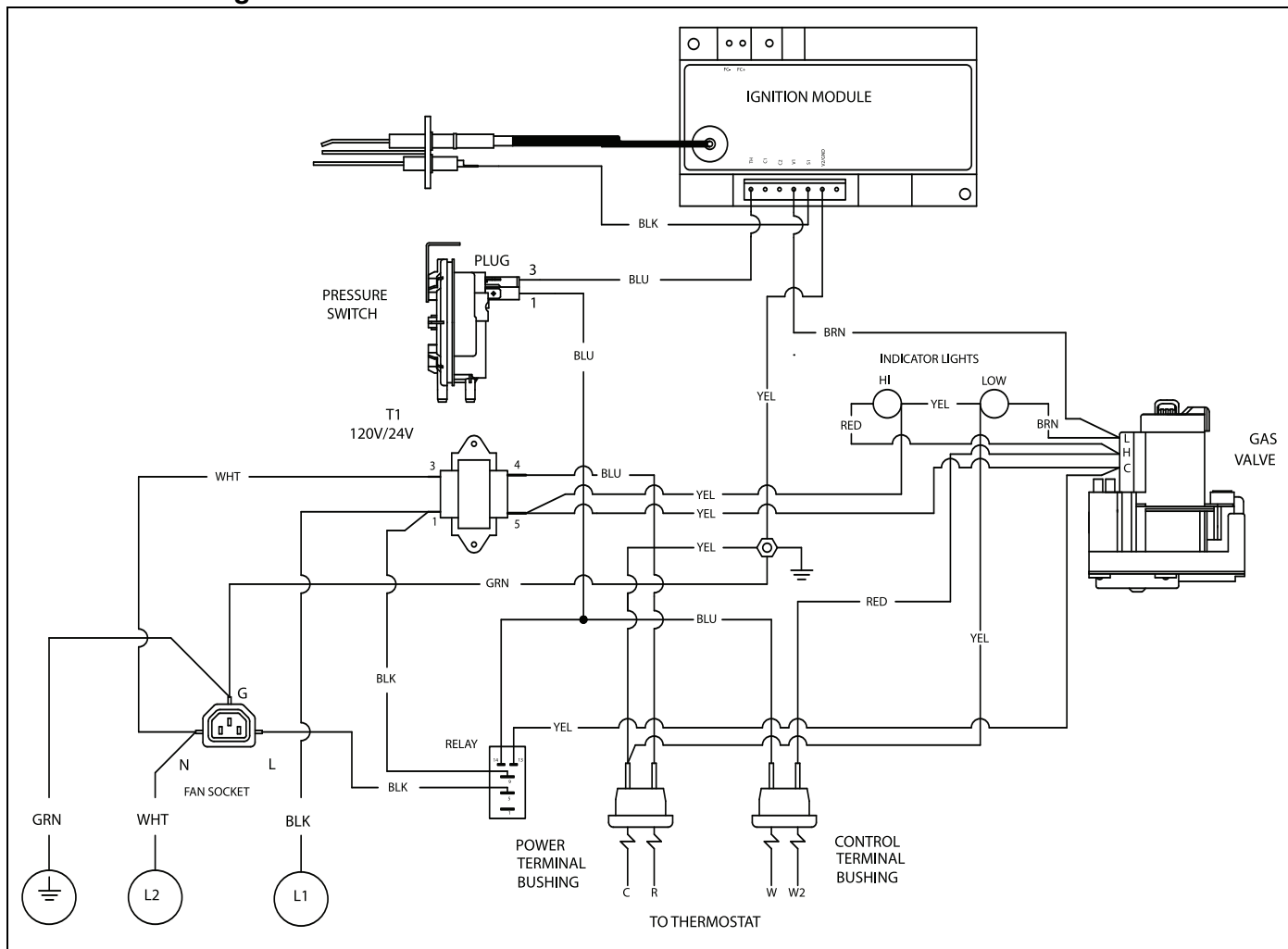



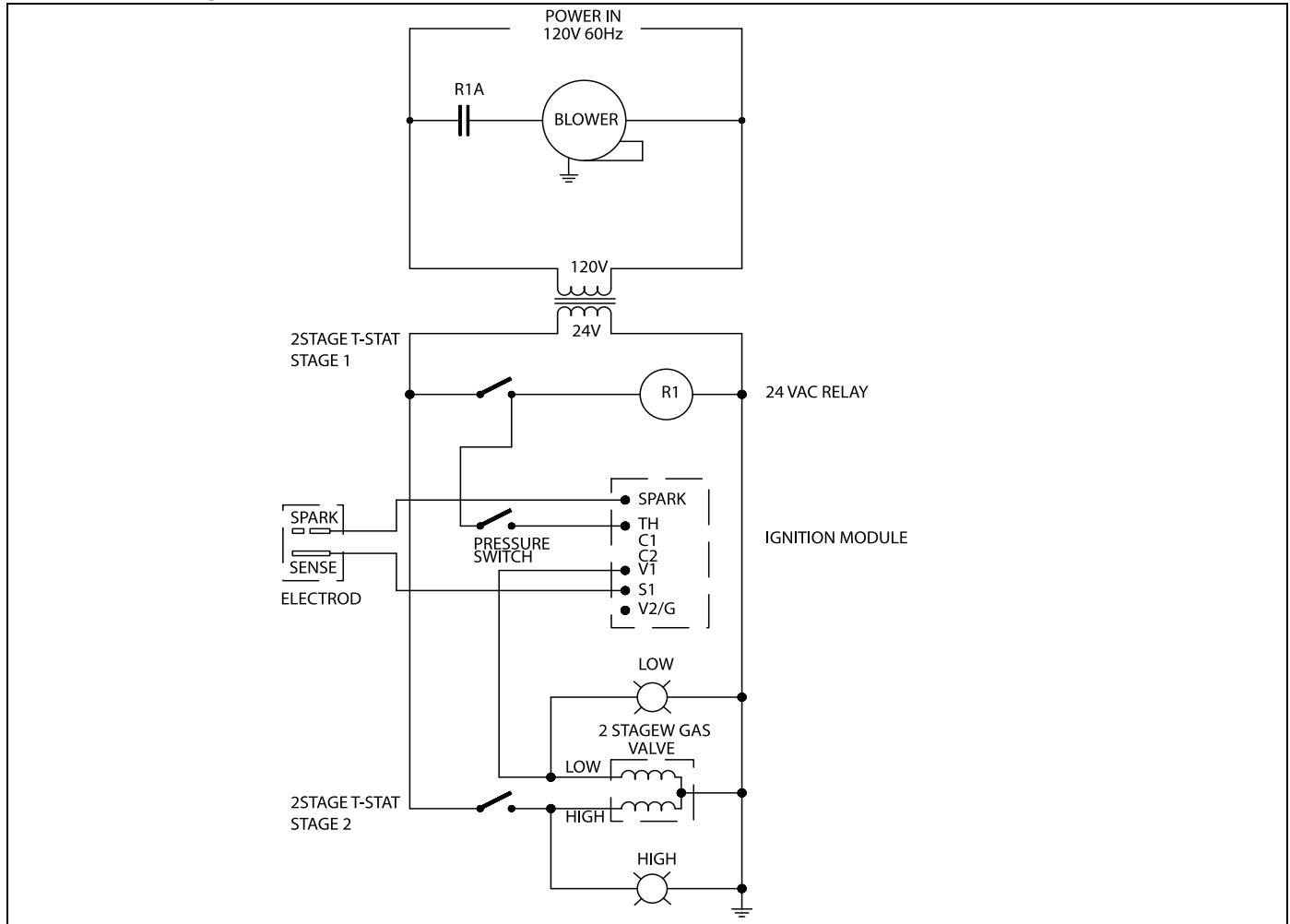

10.4 Ladder Diagram

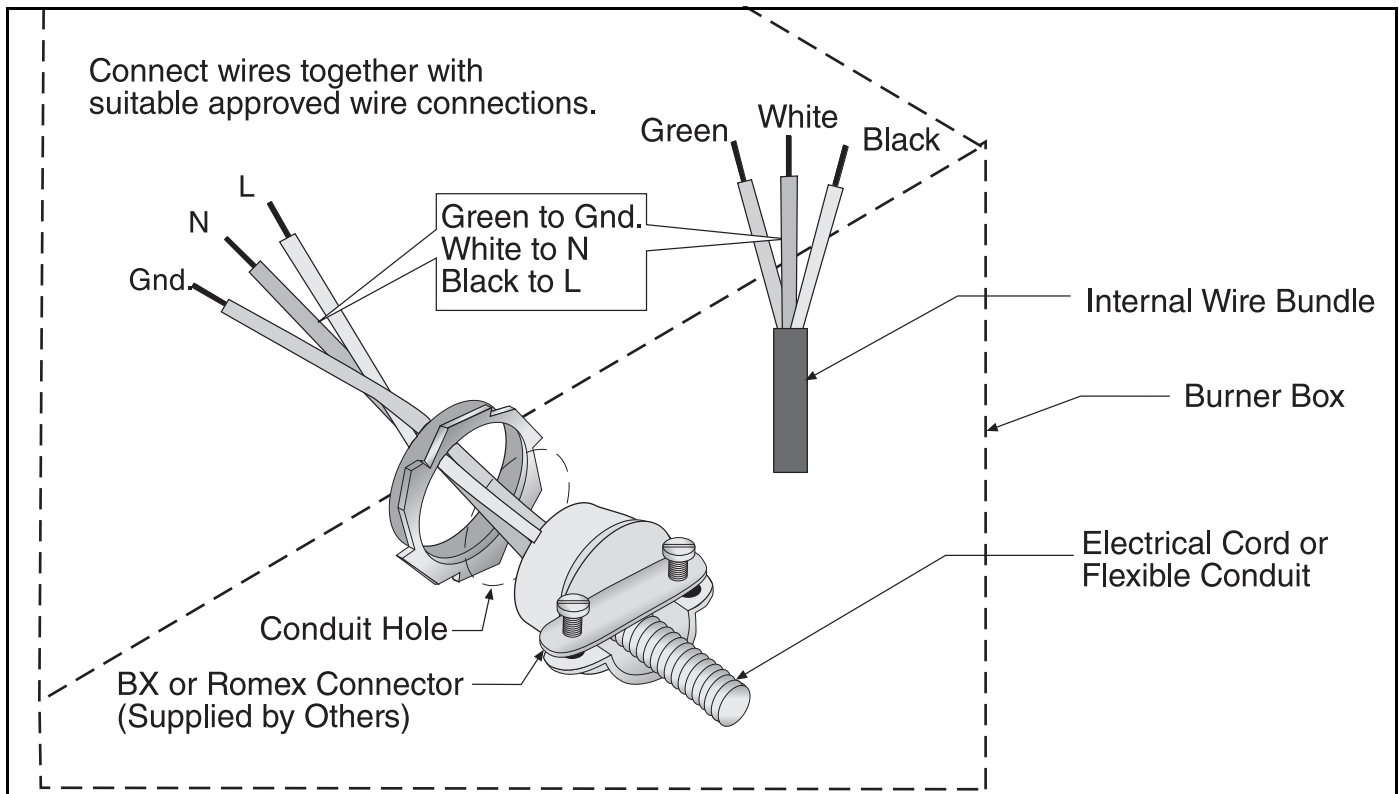

10.5 Electrical Connection to the Burner

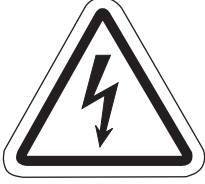

SECTION 11: OPERATION AND MAINTENANCE

| ⚠ DANGER | | ⚠ WARNING | |
|---|---|--|---|
|  |  |  |  |
| Electrical Shock Hazard Disconnect electric before service. Heater must be connected to a properly grounded electrical source. | Explosion Hazard Turn off gas supply to heater before service. | Burn Hazard Allow heater to cool before service. Tubing may still be hot after operation. | Cut/Pinch Hazard Wear protective gear during installation, operation and service. Edges are sharp. |
| Failure to follow these instructions can result in death, electric shock, injury or property damage. | | | |

This heater is equipped with a direct spark ignition system.

11.1 Sequence of Operation

The DF-Series heater is a dual firing heating unit that must be connected to a two-stage thermostat (P/N - 90425412) for correct operation. The ROBERTS GORDON® two-stage thermostat uses an algorithm that controls whether the heater operates on high or low fire. The algorithm output will vary based on load conditions. For example, if the thermostat does not sense a heat rise during a heat cycle within a certain time, it may prompt the DF-Series heater to operate in high fire. The temperature and timing within the algorithm that causes the DF-series burner to fire in high or low fire varies each heat cycle. The thermostat automatically adjusts the DF-Series output during each cycle to improve operation efficiency.

11.2 High/Low Firing Operation

When the thermostat is turned up, the burner will ignite on low fire. The low fire condition is indicated by the low fire indicator light on the burner box that illuminates when the gas valve opens. The high fire condition is indicated by the high fire indicator light that will illuminate when the gas valve switches to high fire.

11.3 Sequence of Operation

1. Turn the thermostat up. When the two-stage thermostat calls for heat, the ignition module will energize the blower motor.
2. When the motor approaches nominal running RPM, the pressure switch closes and activates the ignition module.
3. The ignition module then opens the two-stage gas valve for low fire operation and energizes the spark igniter.
4. When the flame is established, the sparking sequence ceases. The burner is either operating at high fire or low fire depending on the load conditions sensed by the thermostat. If the burner is on high fire, the high fire indicator light will illuminate immediately. The low fire indicator light will illuminate upon ignition and stay energized while the burner is operation, regardless of the firing rate. If the burner is on low fire, only the low fire indicator light will be illuminated.
5. If the flame is not established during the ignition sequence, the ignition module closes the gas valve and purge begins. Module will try 2 additional times for ignition (with purge in between). If ignition is not established, the module will lock out.
6. If the flame extinguishes during operation, the ignition module will provide multiple trial sequence described in step 5. If ignition is not re-established, the module will lock out.
7. After lockout, control must be reset by turning down thermostat for five seconds, and then raising it again to desired temperature, or by disconnecting power and then reconnecting.
8. When the thermostat is satisfied, all power to the unit is shut off.

11.4 To Shut Off Heater

Set thermostat to lowest setting.
 Turn OFF electric power to heater.
 Turn OFF manual gas valve in the heater supply line.

11.5 To Start Heater

Turn gas valve and electric power OFF and wait five minutes for unburned gases to vent from heater.
 Turn ON main gas valve.
 Turn ON electric power.
 Set thermostat to desired temperature.
 Burner should light automatically.

11.6 Pre-Season Maintenance and Annual Inspection

To ensure your safety and years of trouble-free operation of the heating system, service and annual inspections must be done by a contractor qualified in the installation and service of gas-fired heating equipment.
 Turn off gas and electric supplies before performing service or maintenance. Allow heater to cool before servicing.
 Before every heating season, a contractor qualified in the installation and service of gas-fired heating equipment must perform a thorough safety inspection of the heater.

For best performance, the gas, electrical, thermostat connections, tubing, venting, suspensions and overall heater condition should be thoroughly inspected.

NOTE: Gas flow and burner ignition are among the first things that should be thoroughly inspected. Please see *Page 58, Section 11.7* for suggested items to inspect.

11.7 Maintenance Checklist

Installation Code and Annual Inspections:

All installation and service of ROBERTS GORDON® equipment must be performed by a contractor qualified in the installation and service of equipment sold and supplied by Roberts-Gordon LLC and conform to all requirements set forth in the ROBERTS GORDON® manuals and all applicable governmental authorities pertaining to the installation, service, operation and labeling of the equipment.





To help facilitate optimum performance and safety, Roberts-Gordon LLC recommends that a qualified contractor conduct, at a minimum, annual inspections of your ROBERTS GORDON® equipment and perform service where necessary, using only replacement parts sold and supplied by Roberts-Gordon LLC.

| | |
|-----------------------------------|--|
| The Vicinity of the Heater | Do not store or use flammable objects, liquids or vapors near the heater. Immediately remove these items if they are present. |
| | <i>See Page 5, Section 3.</i> |
| Vehicles and Other Objects | Maintain the clearances to combustibles. Do not hang anything from, or place anything on, the heater. Make sure nothing is lodged underneath the reflector, in between the tubes or in the decorative or protective grilles (included with select models). Immediately remove objects in violation of the clearances to combustibles. |
| | <i>See Page 5, Section 3.</i> |
| Reflector | Support reflector with reflector hanger and support strap. Reflector must not touch tube. Make sure there is no dirt, sagging, cracking or distortion. Do not operate if there is sagging, cracking or distortion. Make sure reflectors are correctly overlapped. <i>See Page 30, Section 6.6.1.</i> Clean outside surface with a damp cloth. |
| Vent Pipe | Venting must be intact. Using a flashlight, look for obstructions, cracks on the pipe, gaps in the sealed areas or corrosion. The area must be free of dirt and dust. Remove any carbon deposits or scale using a wire brush. <i>See Page 42, Section 8.</i> |

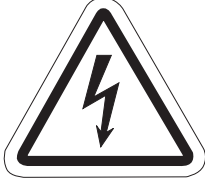
| | |
|--|---|
| Outside Air Inlet | Inlet must be intact. Look for obstructions, cracks on the pipe, gaps in the sealed areas or corrosion. The area must be free of dirt and dust. Clean and reinstall as required. |
| Tubes | Make sure there are no cracks. Make sure tubes are connected and suspended securely. <i>See Page 16, Section 6.</i> Make sure there is no sagging, bending or distortion. Clean or replace as required. |
| Gas Line | Check for gas leaks. <i>See Page 51, Section 9.</i> |
| Burner Observation Window | Make sure it is clean and free of cracks or holes. Clean and replace as required. |
| Blower Scroll, Wheel and Motor | Compressed air or a vacuum cleaner may be used to clean dust and dirt. |
| Burner Cup and Orifice | Clear of obstructions (even spider webs will cause problems). Carefully remove any dust and debris from the burner. |
| Electrode | Replace if there are cracked ceramics, excessive carbon residue, or erosion of the electrode. The electrode gap should be 1/8" (3.2 mm). |
| Thermostat | There should be no exposed wire or damage to the thermostat. <i>See Page 53, Section 10.</i> |
| Suspension Points | Make sure the heater is hanging securely. Look for signs of wear on the chain or ceiling. <i>See Page 17, Figure 15.</i> |
| Decorative and Protective Grille (optional) | The grille must be securely attached. Check that the side reflector extensions are installed correctly and secured in place if necessary. (Decorative grille only.) <i>See Page 39, Section 7.5 and Page 41, Section 7.6</i> Make sure shield is installed correctly and secured in place if necessary. (Decorative grille only.) <i>See Page 40, Section 7.5.2.</i> |
| Lower Clearance Shield (optional) | The lower shield must be securely attached. Inspect shield support straps and lower clearance shield anchor points. <i>See Page 39, Section 7.4.</i> Make sure shield is installed correctly and secured in place if necessary. <i>See Page 39, Section 7.4.</i> |
| Wall Tag | If wall tag is present, make sure it is legible and accurate. Please contact Roberts-Gordon LLC or your ROBERTS GORDON® independent distributor, if you need a wall tag. <i>See Page 4, Section 2.1</i> |
| Safety Labels | Product safety signs or labels should be replaced by the product user when they are no longer legible. Please contact Roberts-Gordon LLC or your ROBERTS GORDON® independent distributor to obtain replacement signs or labels. <i>See Page 2, Figure 1 through Page 3, Figure 2.</i> |

SECTION 12: TROUBLESHOOTING

| |
|--|
| ⚠ DANGER |
|  |
| Electrical Shock Hazard |
| <p>Disconnect electric before service.</p> <p>Heater must be properly earthed.</p> <p>Failure to follow these instructions can result in death or electrical shock.</p> |

| | | | |
|---|---|---|---|
| ⚠ WARNING | | | |
|  |  |  |  |
| Fire Hazard | Explosion Hazard | Burn Hazard | Cut/Pinch Hazard |
| <p>Keep all flammable objects, liquids and vapors the minimum required clearances to combustibles away from heater.</p> <p>Some objects will catch fire or explode when placed close to heater.</p> | <p>Turn off gas supply to heater before service.</p> | <p>Allow heater to cool before service.</p> <p>Tubing may still be hot after operation.</p> | <p>Wear protective gear during installation, operation and service.</p> <p>Edges are sharp.</p> |
| Failure to follow these instructions can result in death, injury or property damage. | | | |

12.1 Troubleshooting Flow Chart

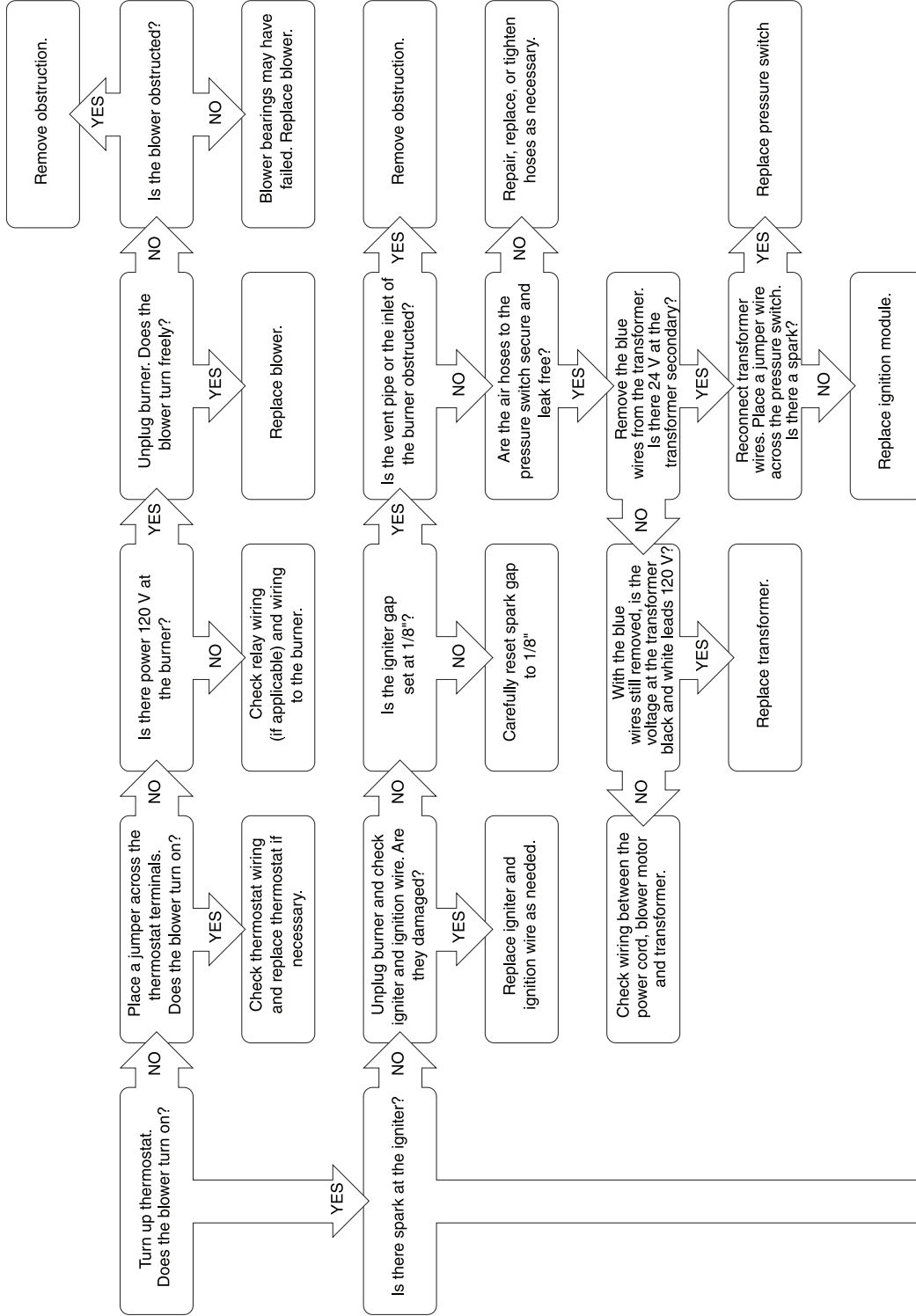

| Module Diagnostic Codes: | |
|---|---|
| LED | Problem |
| 4 second steady flash at start of cycle | Normal |
| Steady on | Microprocessor failure within module |
| Three flashes | Ignition lockout Lockout of module after 3 tries |
| | Solution |
| | Wait for valve to open |
| | Replace module |
| | Recycle unit: check for spark and valve opening and replace:if none, replace module |

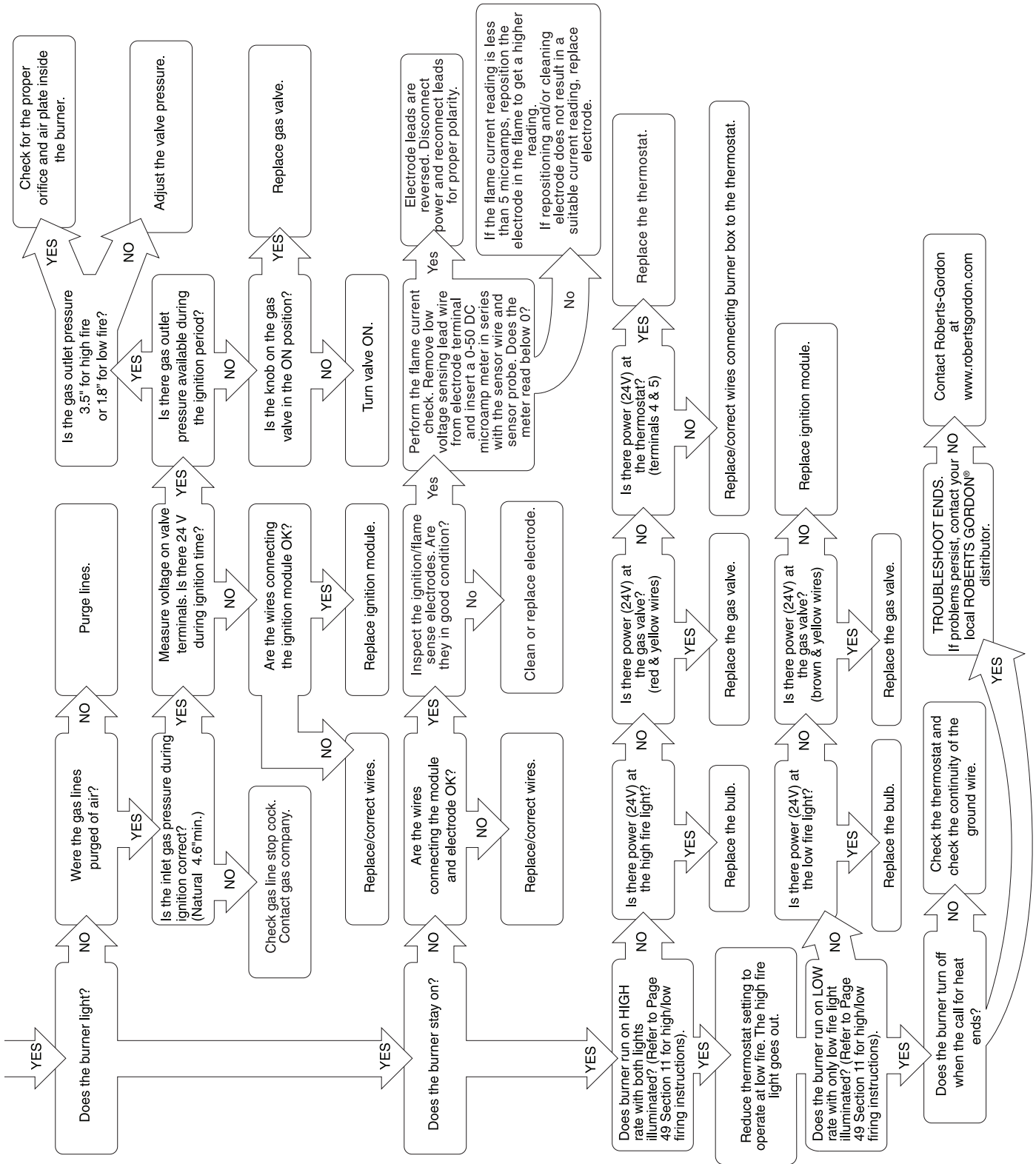

12.2 Manifold Gas Pressure Setting

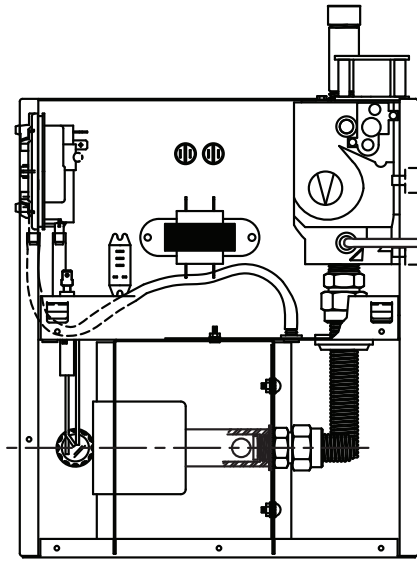

Top View of Heater

Manometer

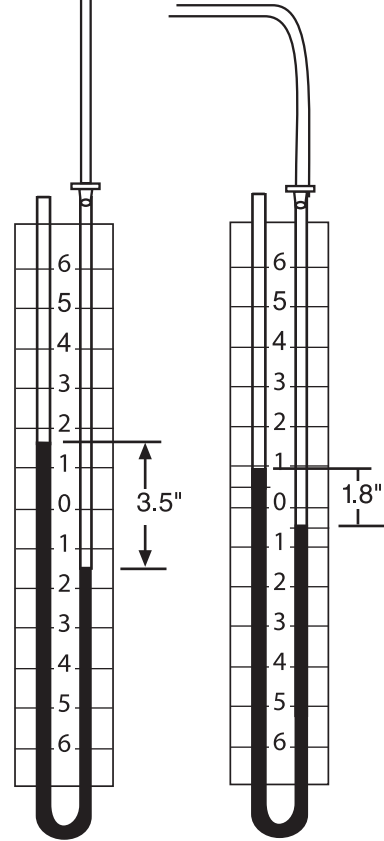





High Fire

Low Fire

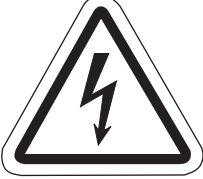
NOTE: Manifold pressure varies by model. Refer to Section 14 for model specific manifold pressures

SECTION 13: REPLACEMENT PARTS

| ⚠ DANGER | ⚠ WARNING | | |
|--|---|--|---|
|  |  |  |  |
| Electrical Shock Hazard | Explosion Hazard | Fire Hazard | Carbon Monoxide Hazard |
| <p>Use only genuine ROBERTS GORDON® replacement parts per this installation, operation and service manual.</p> <p>Failure to follow these instructions can result in death, electric shock, injury or property damage.</p> | | | |

See warnings and important information before removing or replacing parts. After any maintenance or repair work, always test fire the heater in accordance with the start-up instructions on *Page 57, Section 11* to help ensure all safety systems are in working order before leaving the heater to operate. Minor faults may be traced by using the troubleshooting charts on *Page 60, Section 12 through Page 63, Figure 12.2*.

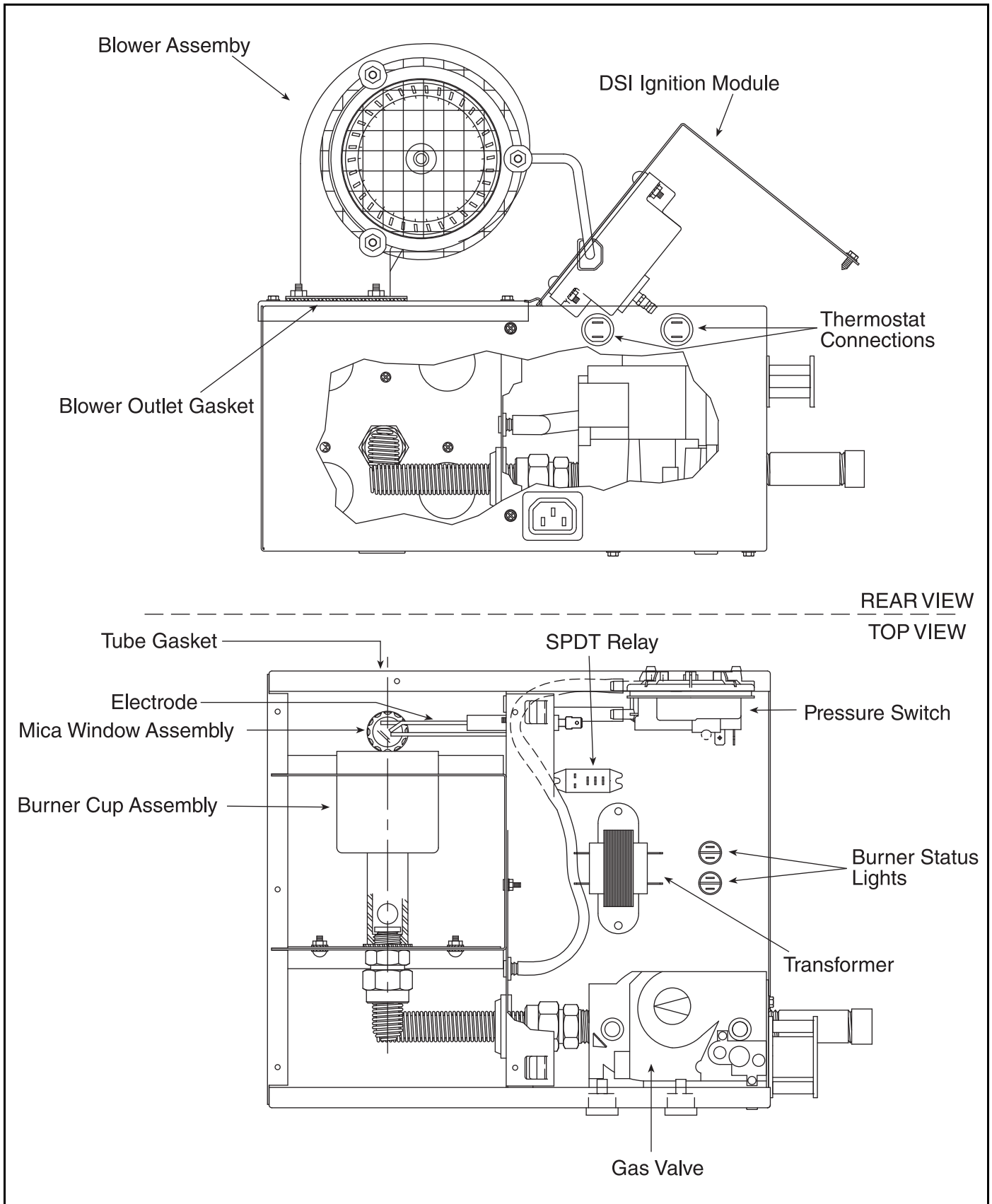

| Description | Part Number |
|-----------------------|--------------------|
| Mica Window Assembly | 02553203 |
| Electrode Gasket | 02558501 |
| Tube Gasket | 02568200 |
| Burner Cup Assembly | 03020100 |
| Gas Valve (Natural) | 90034900 |
| Electrode | 90427400 |
| DSI Ignition Module | 90439500K |
| Transformer | 90436900K |
| Pressure Switch | |
| (200) | 90439801K |
| (175) | 90439802K |
| (125, 150) | 90439803K |
| (80, 100) | 90439805K |
| Motor/Blower Assembly | 90709700-P |
| Blower Outlet Gasket | 90709801 |
| Burner Status Light | 91316103 |
| Relay, SPDT | 90447140 |

SECTION 14: GENERAL SPECIFICATIONS**14.1 Material Specifications****14.1.1 Reflectors**

.024 Aluminum (Standard or High Efficiency Reflectors)
(Optional .024 Stainless Steel Type 304 (Standard Reflectors Only))

14.2 Heater Specifications**14.2.1 Ignition**

Fully automatic, three-try, direct spark, electronic ignition control, 100% safety shut-off.

14.3 Suspension Specifications

Hang heater with materials with a minimum working load of 75 lbs (33 kg). See Page 17, Figure 15.

14.4 Controls Specifications

Time switches, thermostats, etc. can be wired into the electrical supply. External controls supplied as an optional extra.

General Specifications for DF-Series heaters are as follows:

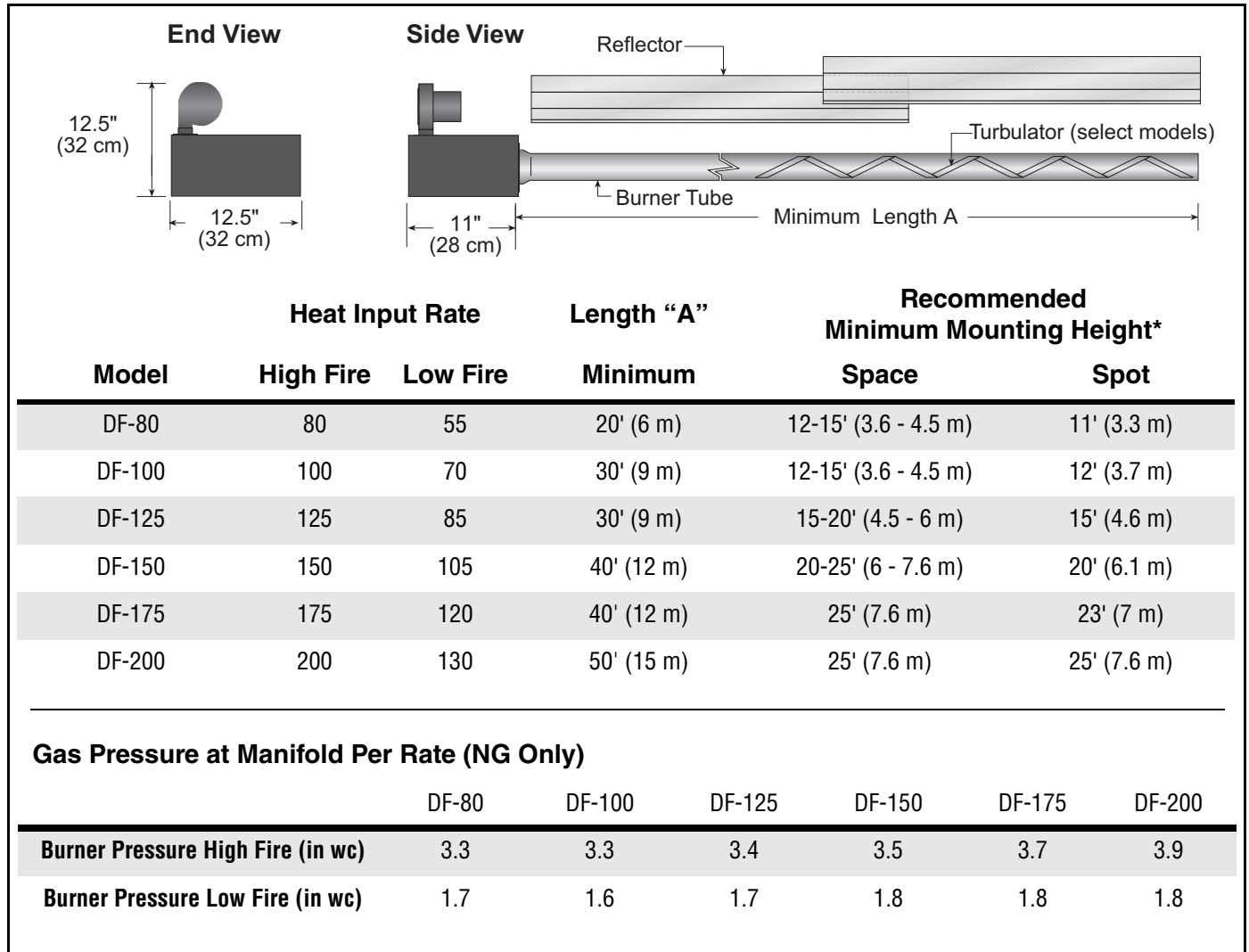

*See Page 5, Section 3 for clearances to combustibles.

GAS PRESSURE AT MANIFOLD:

Natural Gas: 3.5" wc
LP Gas: 10.5" wc

PIPE CONNECTION:

1/2" NPT

DIMENSIONS:

Vent Connection Size: 4" (10 cm)
Outside Air Connection Size: 4" (10 cm)

Refer to figure above for dimensional information.

ELECTRICAL RATING (ALL MODELS):

120 V - 60 Hz, 1 A (run)

GAS INLET PRESSURE:**Natural Gas:**

for BH-40, 60, 80, 100,
115, 125, 140, 150
for BH-175, 200

4.6" wc Minimum
5.0" wc Minimum
14.0" wc Maximum

LP Gas:

11.0" wc Minimum
14.0" wc Maximum

PRODUCT "TYPE" ACCORDING TO ASHRAE HANDBOOK-HVAC SYSTEMS AND EQUIPMENT (LATEST EDITION)

Type: "C" - Indirect Tube-Type Heater (Forced Draft)

SECTION 15: THE ROBERTS GORDON® GORDONRAY® DF WARRANTY

ROBERTS-GORDON LLC WILL PAY FOR:

Within 36 months from date of purchase by buyer or 42 months from date of shipment by Roberts-Gordon LLC (whichever occurs first), replacement parts will be provided free of charge for any part of the product which fails due to a manufacturing or material defect.

Roberts-Gordon LLC will require the part in question to be returned to the factory. Roberts-Gordon LLC will, at its sole discretion, repair or replace after determining the nature of the defect and disposition of part in question.

ROBERTS GORDON® Replacement Parts are warranted for a period of 12 months from date of shipment from Roberts-Gordon LLC or the remaining ROBERTS GORDON® GORDONRAY® DF warranty.

ROBERTS-GORDON LLC WILL NOT PAY FOR:

Service trips, service calls and labor charges.

Shipment of replacement parts.

Claims where the total price of the goods have not been paid.

Damage due to:

- Improper installation, operation or maintenance.
- Misuse, abuse, neglect, or modification of the ROBERTS GORDON® GORDONRAY® DF in any way.
- Use of the ROBERTS GORDON® GORDONRAY® DF for other than its intended purpose.
- Incorrect gas or electrical supply, accident, fire, floods, acts of God, war, terrorism, or other casualty.
- Improper service, use of replacement parts or accessories not specified by Roberts-Gordon LLC.
- Failure to install or maintain the ROBERTS GORDON® GORDONRAY® DF as directed in the Installation, Operation and Service Manual.
- Relocation of the ROBERTS GORDON® GORDONRAY® DF after initial installation
- Use of the ROBERTS GORDON® GORDONRAY® DF in a corrosive atmosphere containing contaminants.
- Use of the ROBERTS GORDON® GORDONRAY® DF in the vicinity of a combustible or explosive material.
- Any defect in the ROBERTS GORDON® GORDONRAY® DF arising from a drawing, design, or specification supplied by or on behalf of the consumer.
- Damage incurred during shipment. Claim must be filed with carrier.

WARRANTY IS VOID IF:

The ROBERTS GORDON® GORDONRAY® DF is not installed by an contractor qualified in the installation and service of gas fired heating equipment.

You cannot prove original purchase date and required annual maintenance history.

The data plate and/or serial number are removed, defaced, modified or altered in any way.

The ownership of the ROBERTS GORDON® GORDONRAY® DF is moved or transferred. This warranty is non-transferable.

Roberts-Gordon LLC is not permitted to inspect the damaged equipment and/or component parts.

READ YOUR INSTALLATION, OPERATION AND SERVICE MANUAL.

If you have questions about your equipment, contact your installing professional. Should you need Replacement Parts or have additional questions, call or write:

Roberts-Gordon LLC

1250 William Street

P.O. Box 44

Buffalo, New York 14240-0044

Telephone: +1.716.852.4400

Fax: +1.716.852.0854

Toll Free: 800.828.7450

www.robertsgordon.com

Roberts-Gordon LLC's liability, and your exclusive remedy, under this warranty or any implied warranty (including the implied warranties of merchantability and fitness for a particular purpose) is limited to providing replacement parts during the term of this warranty. Some jurisdictions do not allow limitations on how long an implied warranty lasts, so this limitation may not apply to you. There are no rights, warranties or conditions, expressed or implied, statutory or otherwise, other than those contained in this warranty.

Roberts-Gordon LLC shall in no event be responsible for incidental or consequential damages or incur liability for damages in excess of the amount paid by you for the ROBERTS GORDON® GORDONRAY® DF.

Some jurisdictions do not allow the exclusion or limitation of incidental or consequential damages, so this limitation or exclusion may not apply to you. This warranty gives you specific legal rights, and you may also have other rights which vary from jurisdiction to jurisdiction.

Roberts-Gordon LLC shall not be responsible for failure to perform under the terms of this warranty if caused by circumstances out of its control, including but not limited to war, fire, flood, strike, government or court orders, acts of God, terrorism, unavailability of supplies, parts or power. No person is authorized to assume for Roberts-Gordon LLC any other warranty, obligation or liability.

LIMITATIONS ON AUTHORITY OF REPRESENTATIVES:

No representative of Roberts-Gordon LLC, other than an Executive Officer, has authority to change or extend these provisions. Changes or extensions shall be binding only if confirmed in writing by Roberts-Gordon LLC's duly authorized Executive Officer.

ROBERTS GORDON®
INFRARED HEATING

OWNER WARRANTY REGISTRATION CARD

Mail or Fax to:

Roberts Gordon LLC • 1250 William Street, P.O. Box 44 • Buffalo, NY 14240-0044 • Phone: 716-852-4400 • Fax: 716-852-0854
www.robertsgordon.com

About the Owner:

Name: _____
Address: _____ City: _____ State: _____ Zip Code: _____
Phone: _____ Fax: _____ E-mail: _____

About the Installer:

Name: _____
Address: _____ City: _____ State: _____ Zip Code: _____
Phone: _____ Fax: _____ E-mail: _____

Purchased From (if different than installer):

Name: _____
Address: _____ City: _____ State: _____ Zip Code: _____
Phone: _____ Fax: _____ E-mail: _____

About your Heater:

Model#: _____ Serial #: _____ Fuel: _____ Installation Date: _____

Type of Installation (check one):

Automotive Manufacturing Warehouse Recreational Aircraft
 Public Building Office Retail Agricultural Other _____

Installation Code and Annual Inspections: All installation and service of ROBERTS GORDON® equipment must be performed by a contractor qualified in the installation and service of equipment sold and supplied by Roberts-Gordon LLC and conform to all requirements set forth in the ROBERTS GORDON® manuals and all applicable governmental authorities pertaining to the installation, service, operation and labeling of the equipment.

To help facilitate optimum performance and safety, Roberts-Gordon LLC recommends that a qualified contractor conduct, at a minimum, annual inspections of your ROBERTS GORDON® equipment and perform service where necessary, using only replacement parts sold and supplied by Roberts-Gordon LLC.

These products are not for residential use.

This product is intended to assist licensed professionals in the exercise of their professional judgment.

©2020 Roberts-Gordon LLC - All rights reserved. No part of this work covered by the copyrights herein may be reproduced or copied in any form or by any means – graphic, electronic, or mechanical, including photocopying, recording, taping, or information storage and retrieval systems – without written permission of Roberts Gordon LLC.
Printed in the U.S.A.

Attach this information to a wall near the ROBERTS GORDON® heater.

ROBERTS GORDON®

Infrared Heating

Read the Installation, Operation, and Service Manual thoroughly before installation, operation, or service.

Know your model number and installed configuration.

Model number and installed configuration are found on the burner and in the Installation, Operation and Service Manual.

Write the largest clearance dimensions with permanent ink according to your model number and configuration in the open spaces below.

| OPERATING INSTRUCTIONS | ⚠ WARNING |
|--|--|
| TO TURN OFF THE HEATER |  Fire Hazard |
| IF THE HEATER WILL NOT OPERATE, TO ENSURE YOUR SAFETY, FOLLOW THESE INSTRUCTIONS TO SHUT DOWN YOUR HEATER | |
| TO TURN OFF THE HEATER | |
| 1. STOP! Read all safety instructions on this information sheet. 2. Open the manual gas valve in the heater supply line. 3. Turn on electric power to the heater. 4. Set the thermostat to desired setting. | Keep all flammable objects, liquids and vapors the minimum required clearances to combustibles away from heater. |
| 1. Set the thermostat to off or the lowest setting. | Some objects will catch fire or explode when placed close to heater. |
| 1. Set the thermostat to off or the lowest setting. 2. Turn off electric power to the heater. 3. Turn off the manual gas valve in the heater supply line. 4. Call your registered installer/contractor qualified in the installation and service of gas-fired heating equipment. | Failure to follow these instructions can result in death, injury or property damage. |

Maintain _____ clearance
 to the side and
 _____ clearance below
 the heater from vehicles
 and combustible materials.

Roberts-Gordon LLC
 1250 William Street
 P.O. Box 44
 Buffalo, NY 14240-0044 USA
 Telephone: +1.716.852.4400
 Fax: +1.716.852.0854

Installation Code and Annual Inspections:

All installation and service of ROBERTS GORDON® equipment must be performed by a contractor qualified in the installation and service of equipment sold and supplied by Roberts-Gordon and conform to all requirements set forth in the ROBERTS GORDON® manuals and all applicable governmental authorities pertaining to the installation, service, operation and labeling of the equipment. To help facilitate optimum performance and safety, Roberts-Gordon recommends that a qualified contractor conduct, at a minimum, annual inspections of your ROBERTS GORDON® equipment and perform service where necessary, using only replacement parts sold and supplied by Roberts-Gordon.

Further Information: Applications, engineering and detailed guidance on systems design, installation and equipment performance is available through ROBERTS GORDON® representatives. Please contact us for any further information you may require, including the Installation, Operation and Service Manual.

This product is not for residential use.

© 2017 Roberts-Gordon LLC All rights reserved. No part of this work covered by the copyrights herein may be reproduced or copied in any form or by any means – graphic, electronic, or mechanical, including photocopying, recording, taping, or information storage and retrieval systems – without written permission of Roberts-Gordon LLC.

www.robertsgordon.com

P/N 91037912 Rev. K