

# ROBERTS GORDON® CARIBE™

## Small Space Utility Heater



MODEL  
CGTH

### Rated for Residential and Light Commercial Environments

- Approved for residential and commercial applications
- Factory-assembled for easy installation
- Longer life provided by durable components
- Compact U-tube design provides maximum inputs at minimum lengths
- One building penetration- balanced flue for both exhaust and combustion air
- Ceiling-mounted to free valuable work space below



[www.robertsgordon.com](http://www.robertsgordon.com)

THE INDUSTRY LEADER  
**RADIANT**  
EFFICIENCY™

# ROBERTS GORDON® THE EXCLUSIVE PRODUCER OF CARIBE™

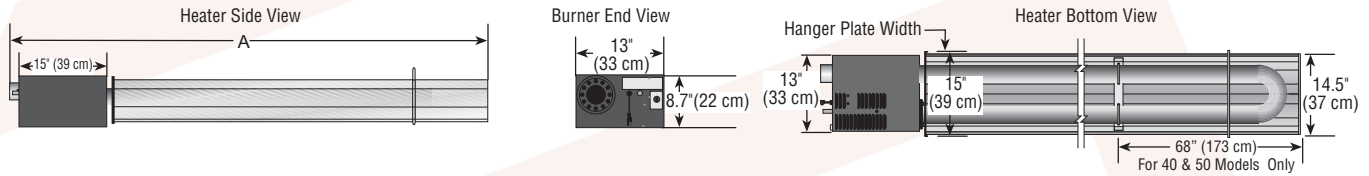

## CARIBE™

Model		CGTH-30	CGTH-40	CGTH-50
Overall Length	[ft, in] A	8', 0"	11', 6"	11', 6"
Weights	[lb]	85	96	96
Input (Btu/h) x (1000)		30	40	50
Fuel		Natural Gas (NG) or Propane Gas (LP)		
Inlet Pressure	[in wc] NG min. LPG Propane min. NG & LPG Propane max.	5 11 14		
Gas Connection	NPT	3/8" (3/8" Manual Shut-off Valve Included with Heater)		
Minimum Mounting Height*	[ft]	7' (Required Safe Distance from Combustibles Must be Maintained)		
Electrical Supply		120 V, 60 Hz, 1 Ø, 1 A (Connection - Cord with 3-Prong Molded Plug)		
Thermostat		Low Voltage, 24 Vac Dual Scale Included with Heater (120 Vac Optional) (Connection - Built-in Receptacle on Heater)		
Heat Exchanger Tubing		3" dia, 16 Gauge, Heat Treated ALUMI-THERM® Steel Tubing		
Exhaust Flue/Vent OD	[in]	3" dia/5" dia (Included with Heater)		
Balanced Flue		Vent Collar and Vent Termination Included with Heater		
Flue Length	[ft, in]	2', 6" Minimum; 10', 0" Maximum		
Reflector and End Caps		.024 Mill Finish Aluminum		
Ignition		Fully Automatic, Three Try, Direct Spark Electronic Ignition Control, 100% Shut-Off		
Approved As		Indoor Vented Overhead Room Heater		
CSA Standards		ANSI Z21.86 / CSA 2.32		
Warranty		Three-Year Limited (Refer to Installation, Operation and Service Manual for details)		
Options		Roof Venting Kit, 90° Elbow Kit, Wall Venting Kits		

\*The minimum mounting height is 10 ft (3 m) for aircraft hangars and 8 ft (2.4 m) for public garages.

### Required Safe Distances from Combustibles \*\*[in]

Model	CGTH-30	CGTH-40	CGTH-50
A	4	4	4
B	16	18	20
C	36	48	48
D	28	30	32
E	34	34	36
F	6	6	6

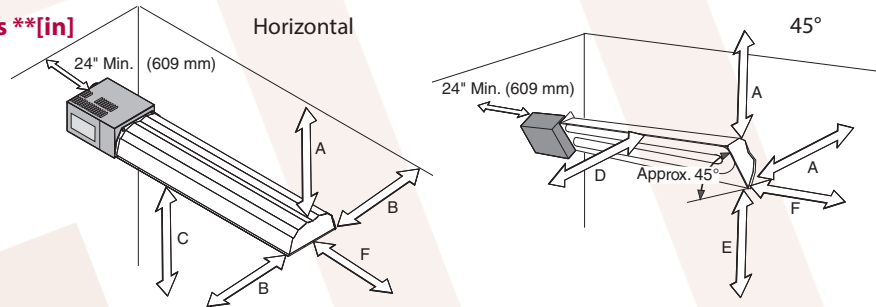

\*\* For complete installation, operation and service criteria, please see the current issue of the Installation, Operation and Service Manual.

**This document is intended to assist licensed professionals in the exercise of their professional judgment.**

Roberts-Gordon LLC  
1250 William Street  
P.O. Box 44  
Buffalo, NY 14240-0044 USA  
Telephone: +1.716.852.4400  
www.robertsgordon.com