

GordonRay® BH

Installation, Operation & Service Manual

BH-40	BH-125
BH-60	BH-150
BH-80	BH-175
BH-100	BH-200

FOR YOUR SAFETY

If you smell gas:

1. Open windows.
2. DO NOT try to light any appliance.
3. DO NOT use electrical switches.
4. DO NOT use any telephone in your building.
5. Leave the building.
6. Immediately call your local gas supplier after leaving the building. Follow the gas supplier's instructions.
7. If you cannot reach your gas supplier, call the Fire Department.

Installer

Please take the time to read and understand these instructions prior to any installation. Installer must give a copy of this manual to the owner.

Owner

Keep this manual in a safe place to provide your serviceman with information should it become necessary.



Quality in Any Language™

Roberts-Gordon, Inc.
 1250 William Street
 P.O. Box 44
 Buffalo, New York 14240-0044
 Telephone: 716.852.4400
 Fax: 716.852.0854
 Toll Free: 800.828.7450

Roberts-Gordon Canada Inc.
 241 South Service Road West
 Grimsby, Ontario L3M 1Y7 Canada
 Telephone: 905.945.5403
 Fax: 905.945.0511
 Toll Free: 800.663.9025

<http://www.rg-inc.com>

► Table of Contents

1 Warnings	1	End Cap	19
Read this section carefully. Improper installation, adjustment, operation or maintenance will result in death, injury or property damage.		Suspension Details	20
2 Introduction	2	Turbulator Assembly	20
Checking Shipment	2	Side Extension Reflector	20
Installer Responsibility	2	U-Tube Package	21
3 Planning	2	Deco Grille	23
National Standards and Applicable Codes		8 Venting and Ducting	24
Gas Codes	2	General Venting Requirements	24
Aircraft Hangars	2	Vent Length Requirements	24
Public Garages	2	Unvented Operation	25
Electrical	3	Horizontal Venting	25
Venting	3	Common Side Wall Venting	25
Hazardous Locations	3	Vertical Venting	26
Critical Considerations	4	Common Vertical Venting	27
Installation Procedure	4	Outside Combustion Air Supply	28
4 Clearances to Combustibles	5	9 Gas Piping	30
5 Standard Parts List	8	10 Wiring	31
6 Assembly Overview	10	Line Voltage Thermostat Wiring	31
Overview Key	10	Low Voltage Thermostat Wiring	31
10 ft. Layout	11	Burner Internal Wiring	32
20 ft. Layout	11	Burner Ladder Diagram	32
30 ft. Layout	12	Electrical Conduit Connection	32
40 ft. Layout	13	11 Operation	33
50 ft. Layout	14	Sequence of Operation	33
60 ft. Layout	15	Maintenance	33
70 ft. Layout	16	12 Troubleshooting	34
80 ft. Layout	17	Troubleshooting Flow Chart	36
7 Component Installation	18	13 Replacement Parts	38
Coupling Assembly	18	14 Engineering Specifications	39
Tube Clamp Package	18	15 General Specifications	40
Reflector Support Package	18	16 Limited Warranty	
Elbows/Reflector Joints	19		

©1995 **ROBERTS GORDON**

All rights reserved. No part of this work covered by the copyrights herein may be reproduced or copied in any form or by any means – graphic, electronic, or mechanical, including photocopying, recording, taping, or information storage and retrieval systems – without written permission of Roberts-Gordon.

▲ WARNING**FIRE OR EXPLOSION HAZARD**

Will result in death, severe injury or property damage.

1. Read this manual carefully before installing or servicing this equipment. Improper installation, service or maintenance will result in death, injury or property damage.
2. Check clearances given on the outside of each burner to make sure the product is suitable for your application.
3. Installer must be a trained, experienced service technician or representative.
4. All service must be performed only by a trained service technician or representative.
5. After installation is complete, check product operation as provided in these instructions.

Combustibles: Failure to maintain the specified minimum clearances to combustibles will result in a serious fire hazard. Do not locate flammable or combustible materials within this distance. Signs should be posted in storage areas to specify maximum stacking height to maintain required clearances to combustibles. Do not locate in hazardous atmospheres containing flammable vapors or combustible dust. **United States:** Installations in public garages or airplane hangars are permitted when in accordance with ANSI Z83.6 and NFPA-409 and 88 Codes. **Canada:** Installation in public garages is permitted when in accordance with CAN/CGA B.149.1 or .2. Installation in airplane hangars is permitted when in accordance with the requirements of the enforcing agency.

Vehicles: Minimum clearances must be maintained from vehicles parked below the heater. Ensure that adequate clearance is maintained where vehicle lifts are in operation.

Gas Connection: There is an expansion of the radiant pipe with each firing cycle, and this will cause the burner to move with respect to the gas line. This can cause a gas leak resulting in an unsafe condition if the gas connection is not made strictly in accordance with Figure 27 of these instructions.

Ignition: This appliance does not have a pilot. It is equipped with an ignition device which automatically lights the burner. Do not try to light the burner with a match.

Mechanical Hazard—Suspension: Use appropriate suspension hardware, beam clamps (rod or perforated strap) and turnbuckles at predetermined locations. The weight and normal movement of the heating system may cause support failure if the following minimum suspension requirements are not met: distance between supports must be 10 ft. (3 m) or less; chain must be general purpose proof coil steel chain, 3/16" or larger in Diameter, with a working load limit of a minimum of 750 lbs. Failure of the supports will cause death, injury or property damage.

▲ WARNING

Failure to follow these instructions will result in personal injury or property damage:

Do not use in an atmosphere containing halogenated hydrocarbons or other corrosive chemicals. Some compounds in the air can be drawn into the equipment and can cause an accelerated rate of corrosion of some parts of the heat exchanger. The use of such chemical compounds in or near the enclosure should be avoided where a longer life of the burner, tubing and other parts is desirable.

Caution should be used when running the system near combustible materials such as wood, paper, rubber, etc. Consideration should be given to partitions, storage racks, hoists, building construction, etc. Figure 1 gives minimum acceptable clearances to combustibles.

If the building has a slight negative pressure or contaminants are present in the air, an outside combustion air supply to the heaters is strongly recommended.

▲ CAUTION

Failure to follow these instructions will result in damage to the system components:

Do not high pressure test the gas piping with the burners connected. Failure to follow this procedure will exceed the pressure rating of burner gas controls and this will require complete replacement of these parts.

This heater is designed for heating nonresidential indoor spaces. These instructions, the layout drawing, local codes and ordinances, and applicable standards that apply to gas piping, electrical wiring, venting, etc., must be thoroughly understood before proceeding with the installation

► Section 2. Introduction

Roberts-Gordon pioneered low-intensity infrared heating systems in 1962 with the introduction of its revolutionary custom-engineered CO-RAY-VAC[®] system. Now Roberts-Gordon offers over 30 years of infrared expertise in a unitary heating system. The BH-Series is a low-cost, non-condensing, field assembled unitary heating system that is easy to install and requires only minimal maintenance. It is designed to provide years of economical operation and trouble-free service.

Checking Shipment

Check the shipment against the Bill of Lading for shortages. Also, check for external damage to cartons. Note any shortages, and/or external damage to cartons on the Bill of Lading in the presence of the carrier. The carrier should acknowledge any shortages or damage by initialing this "noted" Bill of Lading. Immediately report any claims for damaged material, or shortages that were not evident at the time of shipment, to the carrier and your Roberts-Gordon Factory Representative.

Installer Responsibility

All heaters and associated gas piping must be installed in accordance with applicable specifications and this installation made only by firms (or individuals) well qualified in this type of work. Consult local building inspectors, Fire Marshals or your local Roberts-Gordon Representative for guidance.

BH heaters are installed on the basis of information given in a layout drawing, which together with the cited codes and regulations, comprise the basic information needed to complete the installation. The installer must furnish all needed material that is not furnished as standard equipment, and it is his responsibility to see that such materials, as well as the installation methods he uses, result in a job that is workmanlike and in compliance with all applicable codes.

Roberts-Gordon Factory Representatives have had training and experience in the application of this equipment and can be called on for suggestions about installation which can save material and money.

► Section 3. Planning

The following codes and instructions should be followed when planning the installation of the heater. In addition to these instructions, the warnings in Section 1 must be carefully adhered to since improper installation may lead to death, injury or property damage.

National Standards and Applicable Codes

Gas Codes

The type of gas appearing on the nameplate must be the type of gas used. Installation must comply with local codes and recommendations of the local gas company.

United States: Refer to National Fuel Gas Code, ANSI Z223.1 - latest revision, (same as NFPA Bulletin 54).

Canada: Refer to Can 1-B149.1 and B149.2: Installation Codes for Gas Burning Appliances.

- Clearance between the heater and its vent and adjacent combustible material (which is part of the building or its contents) shall be maintained to conform with the above listed codes.

Aircraft Hangars

Installation in aircraft hangars must be in accordance with the following codes: **United States:** Refer to Standard for Aircraft Hangars, ANSI/NFPA-409 - latest revision.

Canada: Refer to Standard CGA B149-1-M91.

- Heaters in aircraft storage or service areas shall be installed a minimum of 10 ft. above the upper surface of wings or engine enclosures of the highest aircraft which may be housed in the hangar. (This should be measured from the bottom of the heater to the wing or engine enclosure, whichever is highest from the floor).
- In other sections of aircraft hangars, such as shops or office, heaters must not be installed less than eight feet above the floor.
- Heaters installed in aircraft hangars shall be located so as not to be subject to damage by aircraft, cranes, movable scaffolding or other objects.

Public Garages

Installation in garages must be in accordance with the following codes: **United States:** Standard for Parking Structures NFPA-88A - latest revision or the Standard for Repair Garages, NFPA 88B - latest revision. **Canada:** Refer to Can 1-B149.1 and B149.2: Installation Codes for Gas Burning Appliances.

- Heaters must not be installed less than eight feet above the floor. Minimum clearances to combustibles must be maintained from vehicles parked below the heater.

- When installed over hoists, minimum clearances to combustibles must be maintained from the uppermost point on the hoist.

Electrical

⚠ WARNING	
	<p style="text-align: center;">Electrical Shock Hazard</p> <p>Heater must be installed and grounded according to national codes.</p> <p>Failure to follow these instructions will result in death or electrical shock.</p>

The heater must be electrically grounded in accordance with the following codes: **United States:** Refer to National Electrical Code, ANSI/NFPA-70 - latest revision. Wiring must conform to the most current National Electrical Code, local ordinances, and any special diagrams furnished. **Canada:** Refer to Canadian Electrical Code, CSA C22.1 Part 1 - latest revision.

Venting



⚠ WARNING	
	<p style="text-align: center;">Carbon Monoxide Hazard</p> <p>Unvented heaters must be interlocked with sufficient building exhaust.</p> <p>Vented heaters must be vented outdoors.</p> <p>Unvented and vented heaters must be installed according to Installation Manual.</p> <p>Failure to follow these instructions will result in death or injury.</p>

The venting must be installed in accordance with the following codes: **United States:** Refer to NFPA-54/ANSI-Z223.1 - latest revision, National Fuel Gas Code. **Canada:** Refer to Can 1-B149.1 and B149.2: Installation Codes for Gas Burning Appliances.

Partial information with regard to these codes is provided in Section 8 of this installation manual with regard to size and configurations for venting arrangements.

Any portion of vent pipe passing through a combustible wall must be dual insulated and have an approved thimble to conform with above listed codes.

Hazardous Locations

⚠ WARNING	
	
<p style="text-align: center;">Fire Hazard</p> <p>Some objects will catch fire or explode when placed close to heater.</p> <p>Keep all flammable objects, liquids and vapors the required safe distances away from heater.</p> <p>Failure to follow these instructions will result in death, injury or property damage.</p>	<p style="text-align: center;">Burn Hazard</p> <p>Keep all persons, especially children, away from heater.</p> <p>Do not touch any part of the heater.</p> <p>Heater is very hot.</p> <p>Failure to follow these instructions will result in severe injury.</p>
⚠ ATTENTION	
<p style="text-align: center;">Risque d'incendie</p> <p>Certains objets placés près du radiateur peuvent s'enflammer ou exploser.</p> <p>Tenir tous les objets, liquides et vapeurs inflammables à la distance de sécurité requisé du radiateur.</p> <p>Le non-respect de ces consignes peut causer mort, blessures ou dommage matériel.</p>	<p style="text-align: center;">Risque de brûlure</p> <p>Ne laisser personne, en particulier des enfants, s'approcher du radiateur.</p> <p>Ne toucher aucune partie du radiateur.</p> <p>Le radiateur est brûlant.</p> <p>Le non-respect de ces consignes peut entraîner des blessures graves.</p>

Where there is the possibility of exposure to combustible airborne material or vapor, consult the local Fire Marshall, the fire insurance carrier or other authorities for approval of the proposed installation.

Critical Consideration

▲ WARNING

Fire Hazard
<p>Some objects will catch fire or explode when placed close to heater.</p> <p>Keep all flammable objects, liquids and vapors the required safe distances away from heater.</p> <p>Failure to follow these instructions will result in death, injury or property damage.</p>
▲ ATTENTION
Risque d'incendie
<p>Certains objets placés près du radiateur peuvent s'enflammer ou exploser.</p> <p>Tenir tous les objets, liquides et vapeurs inflammables à la distance de sécurité requisé du radiateur.</p> <p>Le non-respect de ces consignes peut causer mort, blessures ou dommage matériel.</p>

The BH-Series is a suspended heater. Therefore, its stability, flexibility, and safety are very important. Before starting installation, be sure the system can meet the following requirements:

- Maintain specified clearances to combustibles, and safe distance from heat-sensitive material, equipment and work stations.
- Provide a suspension with vertical length of chain or swinging rod. Be sure the suspension system is sufficiently flexible to accommodate thermal expansion which occurs as the system heats up (see Figure 16).
- Provide access to burners for servicing, preferably on both sides, above, and behind for burner removal.
- Be sure the heater has a downward pitch of 1/2" per 20' (1 cm per 5 m) away from the burner.
- Provide signs in storage areas to specify maximum stacking height to maintain required clearances to combustibles.
- Plan location of supports. Locate a support near all elbows.
- A minimum of 10 ft. (3 m) on BH-60/80 and a minimum of 15 ft. (4.5 m) on BH-100/125/150/175/200 is required between the burner and first elbow.

Installation Procedure

▲ WARNING
<p>Several steps are involved in the installation of the heater.</p> <p>Do not attempt to operate the heater until all steps of the installation have been accomplished.</p> <p>Failure to follow these instructions will result in death, injury or property damage.</p>

Take maximum advantage of the building upper structure, beams, joists, purlins, etc., from which to suspend the heater. There is no unique sequence for installation of the tubing. On-site observation will usually reveal a logical sequence. Begin the installation at the most critical dimension. This could save time. Watch for swinging doors, overhead cranes, car lifts, etc. Reflectors and tubing can be installed as you move along. Carefully adjust system pitch at each position to level the heater. Pitch down 1/2" per 20' (1 cm per 5 m) away from burner.



Don't:

- Pressure test the gas line using high pressure (greater than 1/2 PSIG) without closing the high-pressure shutoff cocks. Failure to do so will result in damage to the burners.

Do:

- Familiarize yourself with local and national codes.
- Develop a planned procedure which will conserve material and labor on the job.
- Check to see that all material and equipment is on the job before starting installation.
- Allow for thermal expansion of the hot tube.
- Install the gas connector only as shown in instructions. (See Figure 27)
- Have slip joints where required between reflectors to keep them from buckling or coming apart.
- Provide one square inch of free air opening to each 1,000 BTU/hr of heater input but not less than 100 square inches in enclosed spaces. (6.5 cm² per 250 kcal/hr). One opening should be within 12 inches (30 cm) of the top and one within 12 inches (30 cm) of the bottom of the enclosure.

► Section 4. Clearances to Combustibles (Minimum Required Safe Distances from Combustibles)

▲ WARNING	
	
Fire Hazard	Burn Hazard
<p>Some objects will catch fire or explode when placed close to heater.</p> <p>Keep all flammable objects, liquids and vapors the required safe distances away from heater.</p> <p>Failure to follow these instructions will result in death, injury or property damage.</p>	<p>Keep all persons, especially children, away from heater.</p> <p>Do not touch any part of the heater.</p> <p>Heater is very hot.</p> <p>Failure to follow these instructions will result in severe injury.</p>
▲ ATTENTION	
Risque d'incendie	Risque de brûlure
<p>Certains objets placés près du radiateur peuvent s'enflammer ou exploser.</p> <p>Tenir tous les objets, liquides et vapeurs inflammables à la distance de sécurité requisé du radiateur.</p> <p>Le non-respect de ces consignes peut causer mort, blessures ou dommage matériel.</p>	<p>Ne laisser personne, en particulier des enfants, s'approcher du radiateur.</p> <p>Ne toucher aucune partie du radiateur.</p> <p>Le radiateur est brûlant.</p> <p>Le non-respect de ces consignes peut entraîner des blessures graves.</p>

In all situations clearances to combustibles must be maintained. Failure to observe clearances to combustibles will result in death, severe injury, or property damage. Signs should be posted in storage areas to specify maximum stacking height to maintain required clearances to combustibles. Minimum clearances must be maintained from vehicles parked below the heater. Caution should be used when running the system near combustible materials such as wood, paper, rubber, etc. Consideration should be given to partitions, storage racks, hoists, building construction, etc. Figure 1 below gives minimum acceptable clearances to combustibles.

NOTE: Clearances B, C, and D can be reduced by 50% for locations 25 ft. or more downstream of the burner.

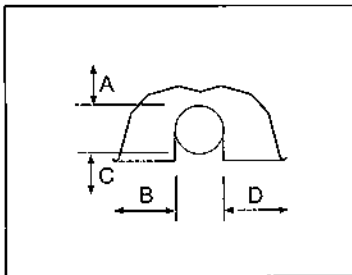

Figure 1a. Standard Reflector

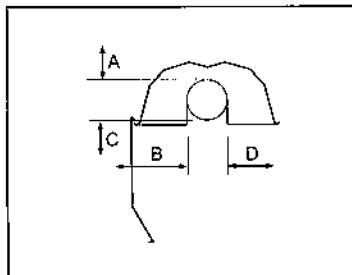

Figure 1b. One Side Reflector

United States (in inches)

Model	A	B	C	D
BH-40	6	27	52	27
BH-60	6	35	62	35
BH-80	6	38	65	38
BH-100	6	40	70	40
BH-125	6	46	76	46
BH-150	6	50	79	50
BH-175	8	52	82	52
BH-200	8	52	82	52

Canada* (in inches)

Model	A	B	C	D
BH-40	6	23	50	23
BH-60	6	27	53	27
BH-80	6	30	59	30
BH-100	6	33	64	33
BH-125	6	35	66	35
BH-150	6	39	71	39
BH-175	8	43	75	43
BH-200	8	43	75	43

Canada* - metric (cm)

Model	A	B	C	D
BH-40	15	58	127	58
BH-60	15	69	135	69
BH-80	15	76	150	76
BH-100	15	84	163	84
BH-125	15	89	168	89
BH-150	15	99	180	99
BH-175	20	109	191	109
BH-200	20	109	191	109

Model	A	B	C	D
BH-40	6	9	52	44
BH-60	6	9	62	47
BH-80	6	9	69	54
BH-100	6	9	76	59
BH-125	6	9	82	65
BH-150	6	9	85	69
BH-175	8	9	88	73
BH-200	8	9	88	73

Model	A	B	C	D
BH-40	6	9	50	35
BH-60	6	9	55	39
BH-80	6	9	61	45
BH-100	6	9	66	50
BH-125	6	9	71	55
BH-150	6	9	75	58
BH-175	8	9	80	61
BH-200	8	9	80	61

Model	A	B	C	D
BH-40	15	23	127	89
BH-60	15	23	135	99
BH-80	15	23	155	114
BH-100	15	23	168	127
BH-125	15	23	180	140
BH-150	15	23	191	147
BH-175	20	23	203	155
BH-200	20	23	203	155

* For Brooder Clearances in Canada, use United States Clearances.

NOTE: Clearances B, C, and D can be reduced by 50% for locations 25 ft. or more downstream of the burner.

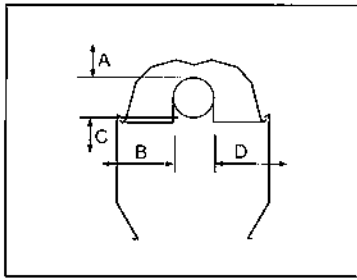

Figure 1c. 2 Side Reflectors

United States (in inches)

Model	A	B	C	D
BH-40	6	15	52	15
BH-60	6	23	65	23
BH-80	6	25	71	25
BH-100	6	27	77	27
BH-125	6	32	83	32
BH-150	6	35	87	35
BH-175	8	40	91	40
BH-200	8	40	91	40

Canada* (in inches)

Model	A	B	C	D
BH-40	6	14	52	14
BH-60	6	20	58	20
BH-80	6	22	63	22
BH-100	6	26	67	26
BH-125	6	29	71	29
BH-150	6	33	77	33
BH-175	8	38	87	38
BH-200	8	38	87	38

Canada* - metric (cm)

Model	A	B	C	D
BH-40	15	36	132	36
BH-60	15	51	147	51
BH-80	15	56	160	56
BH-100	15	66	170	66
BH-125	15	74	180	74
BH-150	15	84	196	84
BH-175	20	97	221	97
BH-200	20	97	221	97

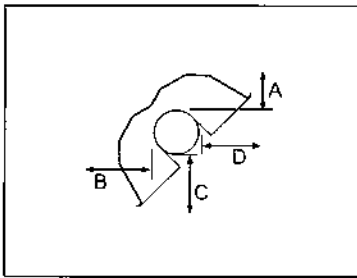

Figure 1d. 45° Tilt Reflector

Model	A	B	C	D
BH-40	8	8	50	46
BH-60	8	8	59	54
BH-80	8	8	65	60
BH-100	10	8	73	64
BH-125	10	8	77	69
BH-150	12	8	83	74
BH-175	12	8	85	79
BH-200	12	8	85	79

Model	A	B	C	D
BH-40	7	7	42	41
BH-60	7	7	47	46
BH-80	7	7	53	52
BH-100	9	7	60	59
BH-125	9	7	64	63
BH-150	11	7	67	66
BH-175	11	7	70	68
BH-200	11	7	70	68

Model	A	B	C	D
BH-40	18	18	107	104
BH-60	18	18	119	117
BH-80	18	18	135	132
BH-100	23	18	152	150
BH-125	23	18	163	160
BH-150	28	18	170	168
BH-175	28	18	178	173
BH-200	28	18	178	173

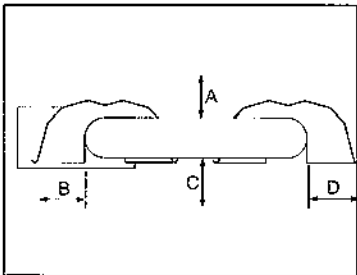

Figure 1e. U-Tube, Standard

Model	A	B	C	D
BH-40	-	-	-	-
BH-60	6	35	62	30
BH-80	6	38	68	37
BH-100	6	40	75	39
BH-125	6	46	78	43
BH-150	6	50	83	47
BH-175	8	54	87	51
BH-200	8	54	87	51

Model	A	B	C	D
BH-40	-	-	-	-
BH-60	6	29	56	25
BH-80	6	33	63	30
BH-100	6	36	66	32
BH-125	6	40	71	36
BH-150	6	42	73	37
BH-175	8	47	78	42
BH-200	8	47	78	42

Model	A	B	C	D
BH-40	-	-	-	-
BH-60	15	74	142	64
BH-80	15	84	160	76
BH-100	15	91	168	81
BH-125	15	102	180	91
BH-150	15	107	185	94
BH-175	20	119	198	107
BH-200	20	119	198	107

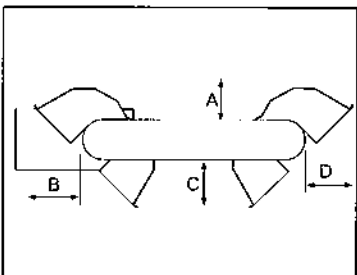

Figure 1f. U-Tube, Opposite 45°

Model	A	B	C	D
BH-40	-	-	-	-
BH-60	8	54	59	22
BH-80	8	60	65	22
BH-100	10	64	73	22
BH-125	10	70	77	22
BH-150	12	74	83	22
BH-175	12	76	85	22
BH-200	12	76	85	22

Model	A	B	C	D
BH-40	-	-	-	-
BH-60	7	46	47	17
BH-80	7	52	53	17
BH-100	9	59	60	17
BH-125	9	63	64	17
BH-150	11	66	67	17
BH-175	11	70	80	17
BH-200	11	70	80	17

Model	A	B	C	D
BH-40	-	-	-	-
BH-60	18	117	119	43
BH-80	18	132	135	43
BH-100	23	150	152	43
BH-125	23	160	163	43
BH-150	28	168	170	43
BH-175	28	178	203	43
BH-200	28	178	203	43

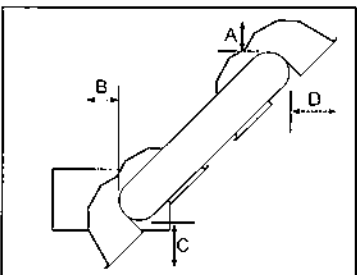

Figure 1g. U-Tube, Full 45°

Model	A	B	C	D
BH-40	-	-	-	-
BH-60	8	8	59	42
BH-80	8	8	65	46
BH-100	8	8	73	52
BH-125	8	8	77	61
BH-150	8	8	83	66
BH-175	8	8	85	70
BH-200	8	8	85	70

Model	A	B	C	D
BH-40	-	-	-	-
BH-60	7	7	47	36
BH-80	7	7	53	44
BH-100	7	7	60	49
BH-125	7	7	64	55
BH-150	7	7	67	58
BH-175	7	7	71	63
BH-200	7	7	71	63

Model	A	B	C	D
BH-40	-	-	-	-
BH-60	18	18	119	91
BH-80	18	18	135	112
BH-100	18	18	152	124
BH-125	18	18	163	140
BH-150	18	18	170	147
BH-175	18	18	180	160
BH-200	18	18	180	160

* For Brooder Clearances in Canada, use United States Clearances.

NOTE: Clearances B, C, and D can be reduced by 50% for locations 25 ft. or more downstream of the burner.

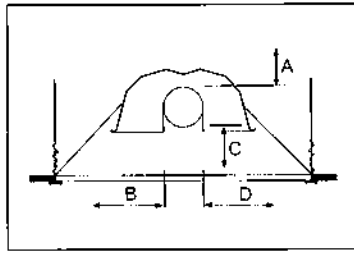

Figure 1h. 2-Foot Deco Grille

United States (in inches)

Model	A	B	C	D
BH-40	6	27	52	27
BH-60	6	35	62	35
BH-80	6	38	65	38
BH-100	6	40	70	40
BH-125	6	46	76	46
BH-150	6	50	79	50
BH-175	8	52	82	52
BH-200	8	52	82	52

Canada* (in inches)

Model	A	B	C	D
BH-40	6	23	50	23
BH-60	6	27	53	27
BH-80	6	30	59	30
BH-100	6	33	64	33
BH-125	6	35	66	35
BH-150	6	39	71	39
BH-175	8	43	75	43
BH-200	8	43	75	43

Canada* - metric (cm)

Model	A	B	C	D
BH-40	15	58	127	58
BH-60	15	69	135	69
BH-80	15	76	150	76
BH-100	15	84	163	84
BH-125	15	89	168	89
BH-150	15	99	180	99
BH-175	20	109	191	109
BH-200	20	109	191	109

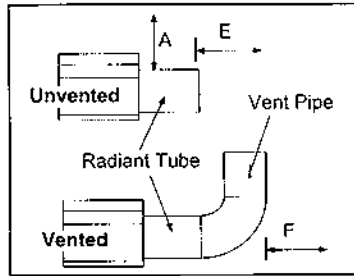

Figure 1i. Venting

Model	A	E	F
BH-40	14	18	18
BH-60	14	18	18
BH-80	20	24	18
BH-100	20	24	18
BH-125	20	24	18
BH-150	20	30	18
BH-175	20	30	18
BH-200	20	30	18

Model	A	E	F
BH-40	14	18	18
BH-60	14	18	18
BH-80	20	24	18
BH-100	20	24	18
BH-125	20	24	18
BH-150	20	30	18
BH-175	20	30	18
BH-200	20	30	18

Model	A	E	F
BH-40	36	46	46
BH-60	36	46	46
BH-80	51	61	46
BH-100	51	61	46
BH-125	51	61	46
BH-150	51	76	46
BH-175	51	76	46
BH-200	51	76	46

► Section 5. Standard Parts List

The following section provides information about assembling BH-Series heaters. The heaters must be assembled according to the following illustrations and tables in order to ensure safe and proper operation.

BH-Series burner cartons contain the basic burner unit, a Pipe Nipple and Flex Gas Line for gas connection, and an Outside Air Adapter. Turbulators (when required) are listed in Table 1.

The remaining heater components are shipped in one of two ways:

- 1) Typically, tubes, reflectors, hangers, etc. are pre-packaged at the factory. Components for heaters of up to 40 ft. (12 m) length are accommodated in one carton that includes a 10 ft. (3 m) transition tube. Longer heaters require two accessory cartons. One carton will include a transition tube. (A few minor components

such as end caps may be duplicated.) Necessary packages for the various heaters are shown in Table 1 below. Components should be assembled as per Figures 2 through 20.

- 2) In some cases, BH-Series heaters may be received with the accessory components non-cartoned, or packaged for a specific installation. In those cases, be sure to acquaint yourself with the individual components shown in Figure 2. Also follow carefully the appropriate diagram (Figures 3 through 9) for the heater you ordered. These indicate the quantity and location of all necessary components.

Figures 10 through 20 show specific assembly details. Refer to Section 8 for venting assembly, Section 9 for gas piping assembly, and Section 10 for field wiring.

Table 1. BH-Series Component Package Guide

Model	Tubing Length		Required Accessory Packages		For Assembly see page
	Minimum	Optional	Standard	Aluminized	
BH-40	10' (3 m)	-	-	CP10ALUM	pg 11
BH-60	20' (6 m)	-	CP20HRS	CP20ALUM	pg 11
BH-80	20' (6 m)	-	CP20HRS	CP20ALUM	pg 11
	-	30' (9 m)	CP30HRS	CP30ALUM	pg 12
BH-100	30' (9 m)	-	CP30HRS	CP30ALUM	pg 12
	-	40' (12 m)	CP40HRS	CP40ALUM	pg 13
BH-125	30' (9 m)	-	CP30HRS	CP30ALUM	pg 12
	-	40' (12 m)	CP40HRS	CP40ALUM	pg 13
	-	50' (15 m)	CP30HRS + EXP20HRS	CP30ALUM + EXP20ALUM	pg 14
BH-150	40' (12 m)	-	CP40HRS	CP40ALUM	pg 13
	-	50' (15 m)	CP30HRS + EXP20HRS	CP30ALUM + EXP20ALUM	pg 14
	-	60' (18 m)	CP30HRS + EXP30HRS	CP30ALUM + EXP30ALUM	pg 15
BH-175	50' (15 m)	-	CP30HRS + EXP20HRS	CP30ALUM + EXP20ALUM	pg 14
	-	60' (18 m)	CP30HRS + EXP30HRS	CP30ALUM + EXP30ALUM	pg 15
	-	70' (21 m)	CP40HRS + EXP30HRS	CP40ALUM + EXP30ALUM	pg 16
BH-200	60' (18 m)	-	CP30HRS + EXP30HRS	CP30ALUM + EXP30ALUM	pg 15
	-	70' (21 m)	CP40HRS + EXP30HRS	CP40ALUM + EXP30ALUM	pg 16
	-	80' (24 m)	CP40HRS + EXP40HRS	CP40ALUM + EXP40ALUM	pg 17

Table 2. Contents of BH-Series Burner Shipping Carton

Part No.	Description	BH-40	-60	-80	-100	-125	-150	-175	-200
	BH-Series Burner Assembly (rate and fuel varies)	1	1	1	1	1	1	1	1
90709700	Blower Assembly with Cord	1	1	1	1	1	1	1	1
02568200	Gasket (Burner to Transition Tube)	1	1	1	1	1	1	1	1
90709801	Gasket (Blower to Burner)	1	1	1	1	1	1	1	1
170101NA	Installation Manual	1	1	1	1	1	1	1	1
91201708	Pipe Nipple (Black) 1/2 x 3-1/2	1	1	1	1	1	1	1	1
94273914	Hex Head Rolok 5/16 - 18 - 2A x 7/8	4	4	4	4	4	4	4	4
96411600	Split Lockwasher	4	4	4	4	4	4	4	4
91412200	Flexible Gas Connector Assembly, 1/2" NPT	1	1	1	1	1	-	-	-
91412203	Flexible Gas Connector Assembly, 3/4" NPT	-	-	-	-	-	1	1	1
91907302	S-Hooks	2	2	2	2	2	2	2	2
91911700	Outside Air Collar	1	1	1	1	1	1	1	1
94118106	#8 x 3/8 Hex Washer Head (for Outside Air Collar)	3	3	3	3	3	3	3	3
92311800	Keps Nut	4	4	4	4	4	4	4	4
03051503	Turbulator Adapter, Aluminized Steel	1	1	1	1	1	1	-	-
03051504	Turbulator 2.5 ft. (76 cm) Section Piece, Aluminized Steel	2	4	4	2	3	2	-	-
03051505	Turbulator 2.5 ft. (76 cm) Section Piece, Stainless Steel	1	-	-	-	-	-	-	-

Table 3. Contents of Accessory Packages

Part No.	Description	Core Packages				Extension Packages										
		Hot Rolled		Aluminized		Hot Rolled		Aluminized								
		20'	30'	40'	10'	20'	30'	40'	10'	20'	30'	40'				
91409300	Tube, Hot Rolled Steel, 10 ft.	1	2	3	-	-	-	-	1	2	3	4	-	-	-	-
91409408	Tube, HT Aluminized, 10 ft.	-	-	-	-	1	2	3	-	-	-	-	1	2	3	4
03051100	Transition Tube, Aluminized, 10 ft.	1	1	1	-	1	1	1	-	-	-	-	-	-	-	-
03051600	Transition Tube, HT Aluminized, 10 ft.	-	-	-	1	-	-	-	-	-	-	-	-	-	-	-
01312700	Standard Coupling Assembly	1	2	3	-	1	2	3	1	2	3	4	1	2	3	4
02750303	Standard 8 ft. Reflector	3	4	6	2	3	4	6	2	3	4	6	2	3	4	6
02750800	End Cap	2	2	2	2	2	2	2	-	-	-	-	-	-	-	-
03090100	Tube and Reflector Hanger	3	4	5	2	3	4	5	1	2	3	4	1	2	3	4
91907302	S-Hook	3	4	5	2	3	4	5	1	2	3	4	1	2	3	4
03050010	Refl. Support Pkg. (Strap, Wire Form, Screws)	2	3	5	1	2	3	5	2	3	4	6	2	3	4	6
91107720	U-Clip Package	1	1	1	1	1	1	1	1	1	1	1	1	1	1	1
90502700	Vent Adapter	1	1	1	1	1	1	1	-	-	-	-	-	-	-	-
01318901	Tube Clamp Package	1	1	1	1	1	1	1	-	-	-	-	-	-	-	-
	Package Part Numbers:	CP20HRS	CP30HRS	CP40HRS	CP10ALUM	CP20ALUM	CP30ALUM	CP40ALUM	EXP10HRS	EXP20HRS	EXP30HRS	EXP40HRS	EXP10ALUM	EXP20ALUM	EXP30ALUM	EXP40ALUM

► Section 6. Assembly Overview

The figures in this section provide a general overview of component placement in a BH-Series system. The location of some components such as supports and couplings is crucial to proper installation. Assemble the heater components as shown in Figures 3 through 9.

Optional reflector configurations are shown in Figure 1. Install appropriate suspension hardware, beam clamps, chain or rod at predetermined locations. Adjustment of chain length will provide uniform pitch. Four inches of tubing at the transition area and at the vent end of the heat exchanger may be left uncovered by reflector.

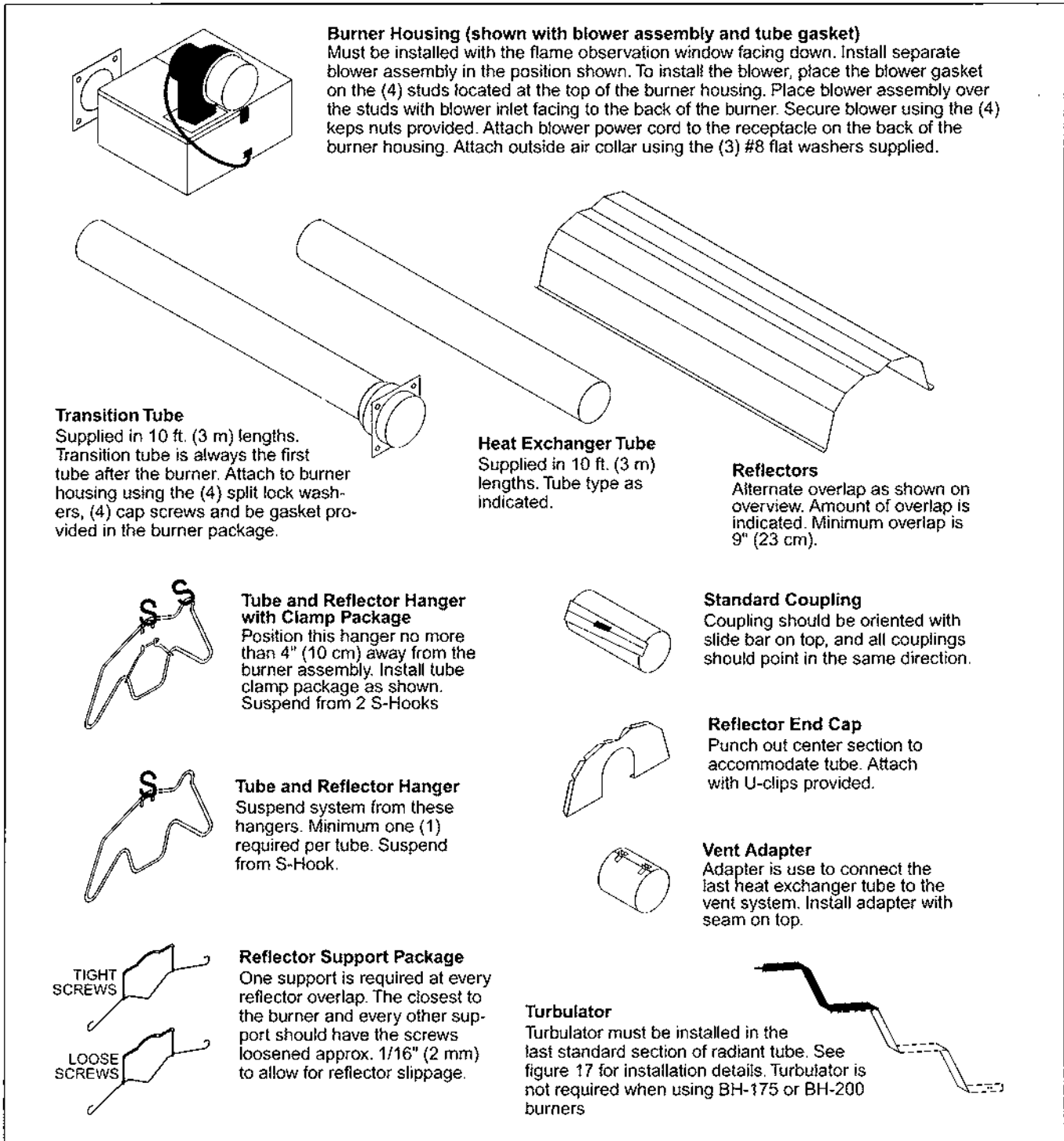

Figure 2. Assembly Overview

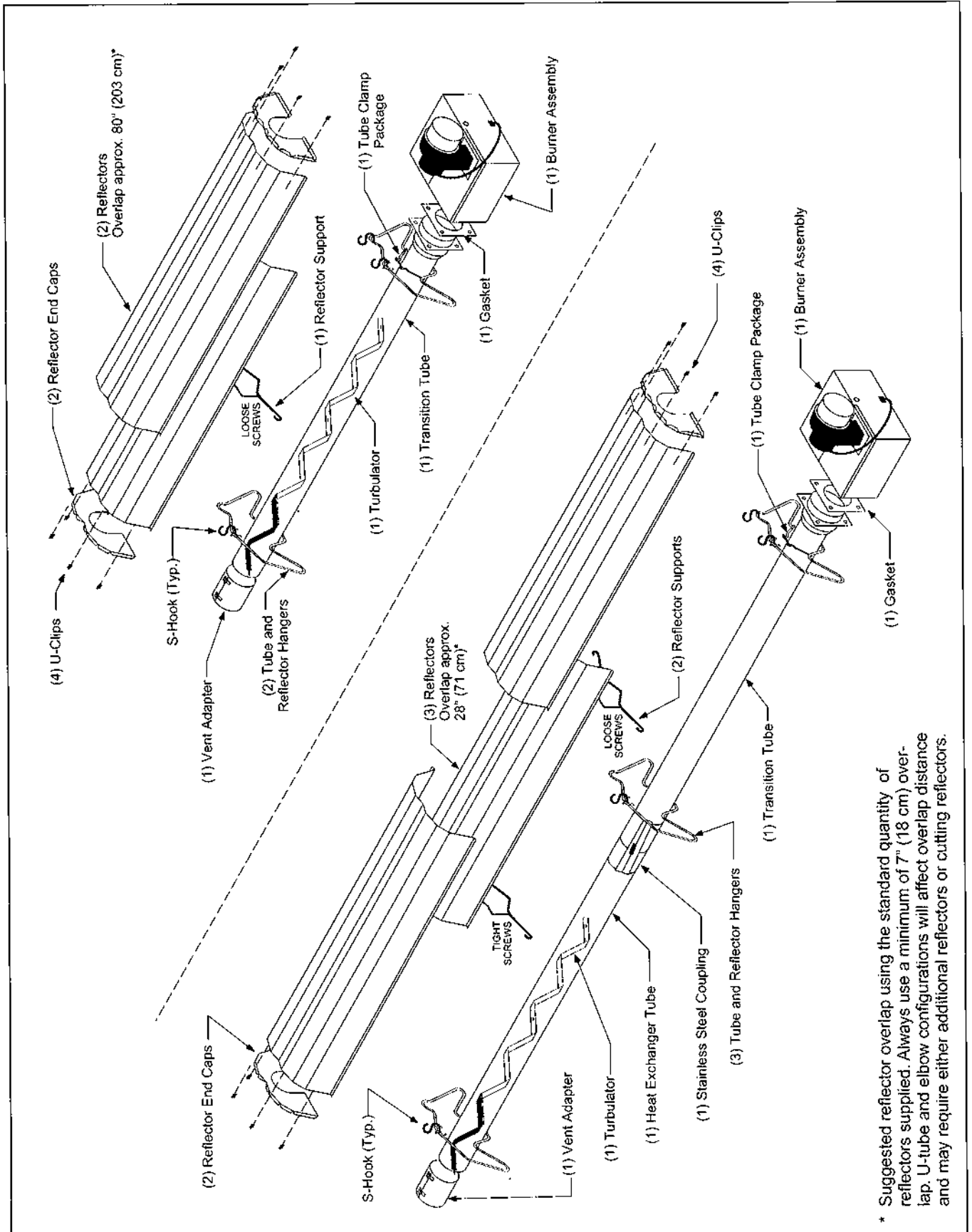
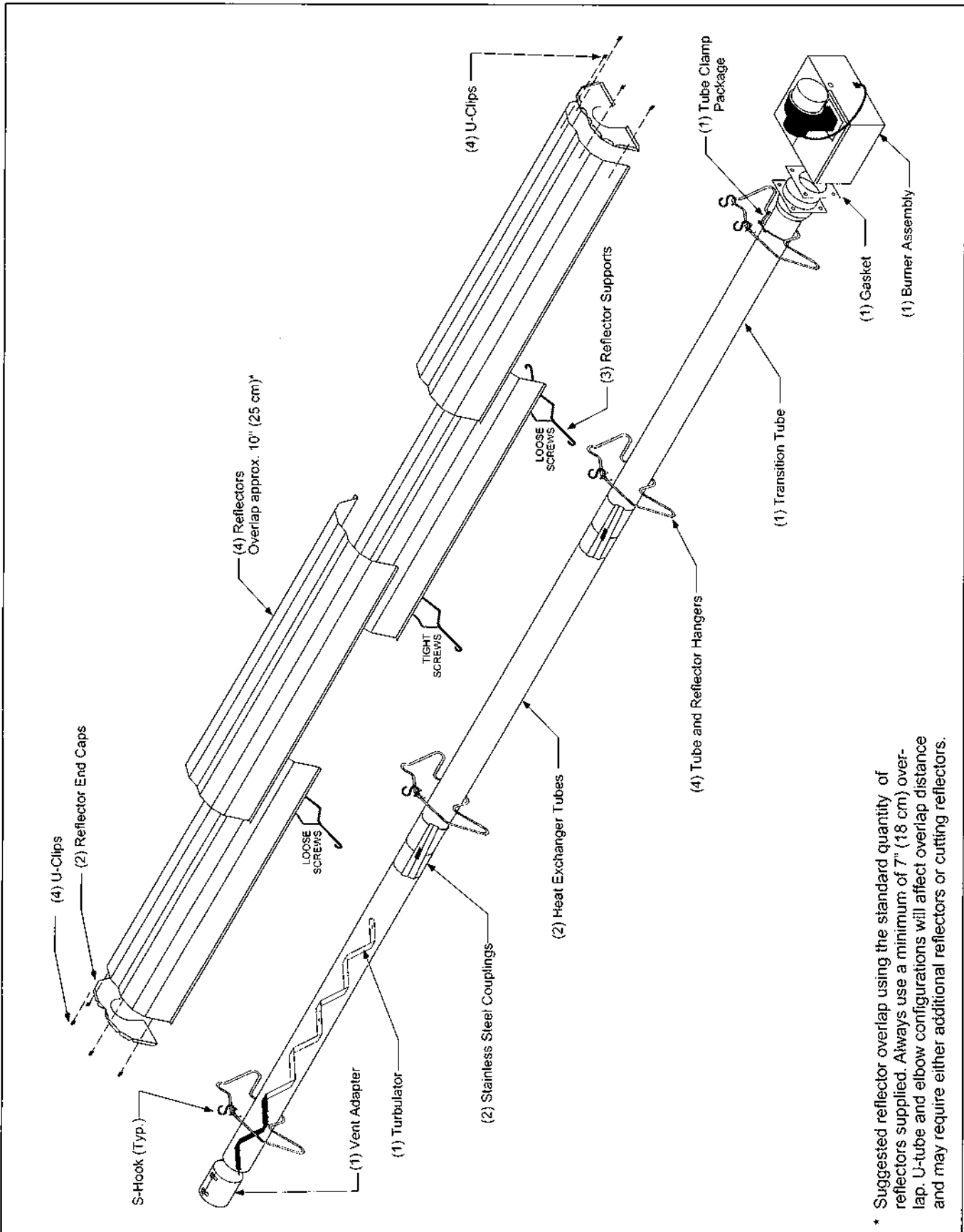

Figure 3. Assembly of 10 ft (3 m) Heat Exchanger System
 Assembly of 20 ft (6 m) Heat Exchanger System

* Suggested reflector overlap using the standard quantity of reflectors supplied. Always use a minimum of 7" (18 cm) overlap. U-tube and elbow configurations will affect overlap distance and may require either additional reflectors or cutting reflectors.



* Suggested reflector overlap using the standard quantity of reflectors supplied. Always use a minimum of 7" (18 cm) overlap. U-tube and elbow configurations will affect overlap distance and may require either additional reflectors or cutting reflectors.

Figure 4. Assembly of 30 ft (9 m) Heat Exchanger System

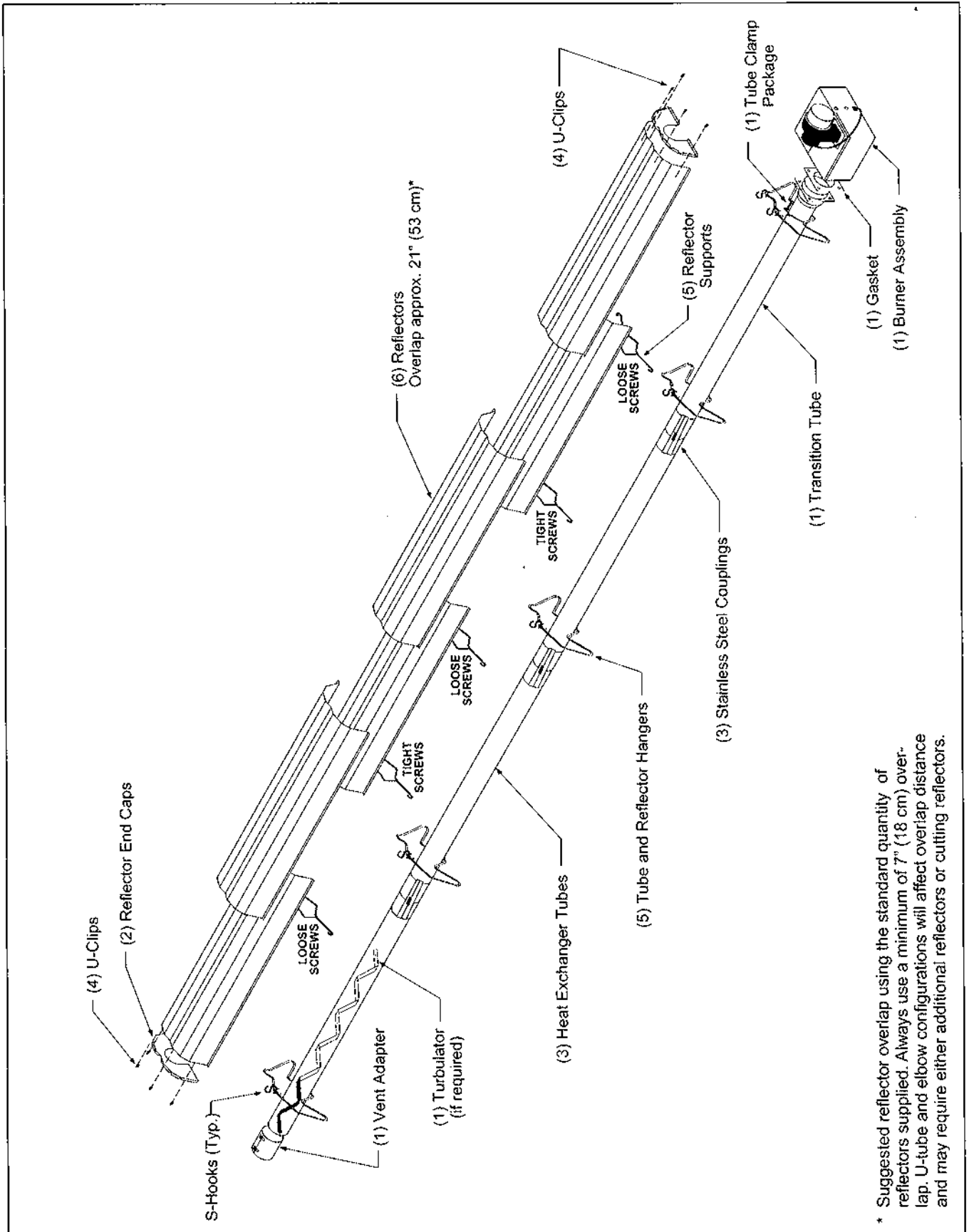

* Suggested reflector overlap using the standard quantity of reflectors supplied. Always use a minimum of 7" (18 cm) overlap. U-tube and elbow configurations will affect overlap distance and may require either additional reflectors or cutting reflectors.

Figure 5. Assembly of 40 ft (12 m) Heat Exchanger System

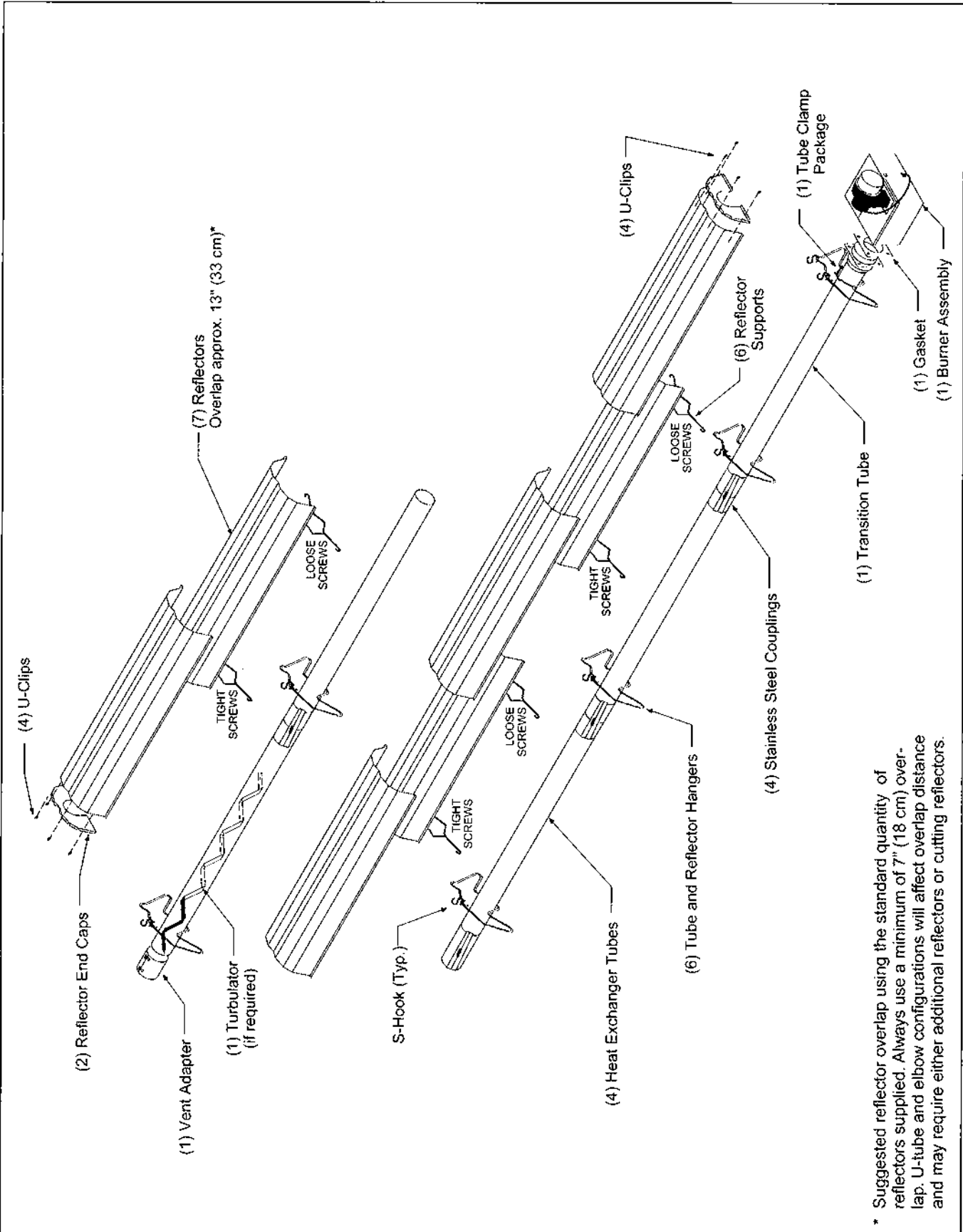

* Suggested reflector overlap using the standard quantity of reflectors supplied. Always use a minimum of 7" (18 cm) overlap. U-tube and elbow configurations will affect overlap distance and may require either additional reflectors or cutting reflectors.

Figure 6. Assembly of 50 ft (15 m) Heat Exchanger System

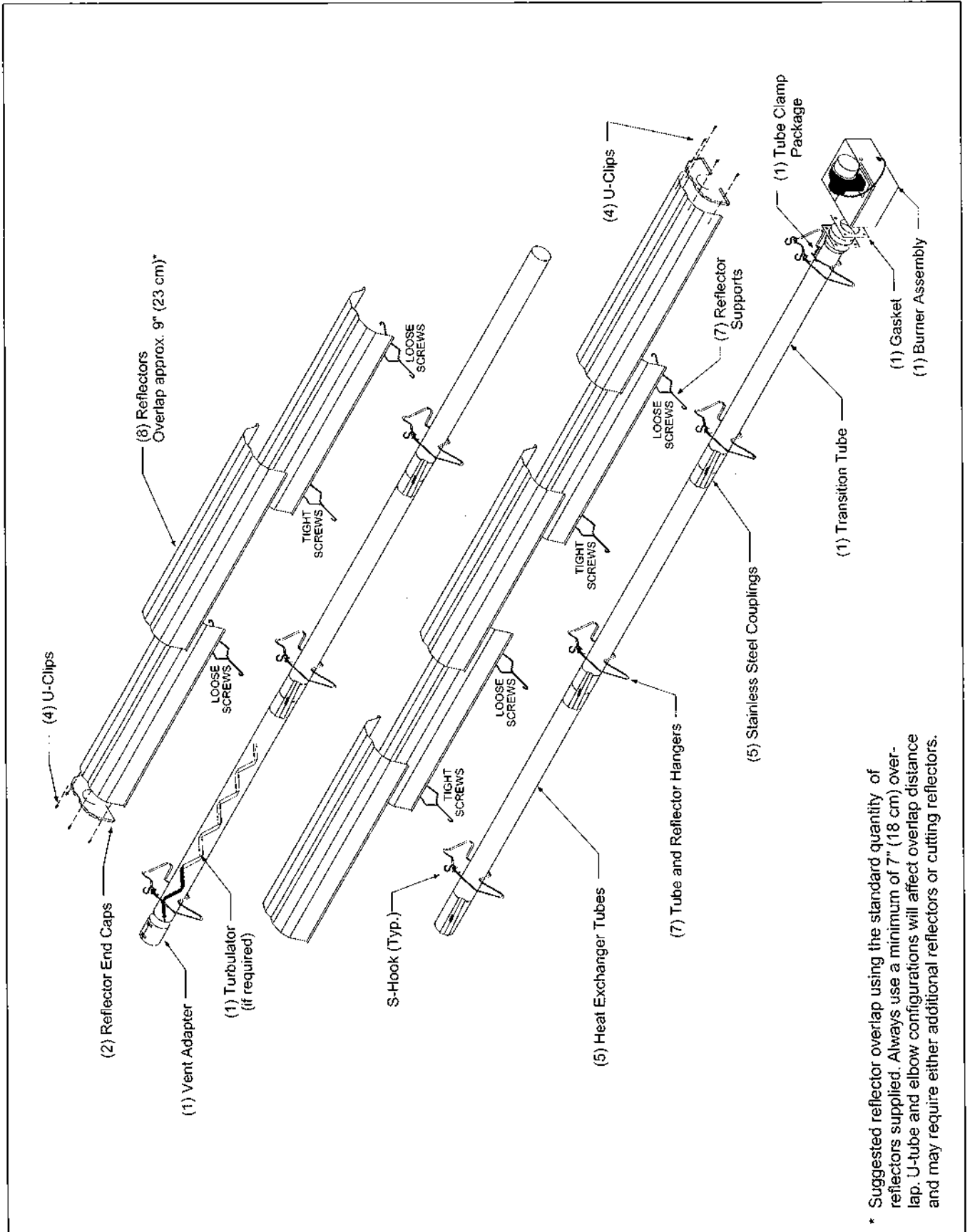

* Suggested reflector overlap using the standard quantity of reflectors supplied. Always use a minimum of 7" (18 cm) overlap. U-tube and elbow configurations will affect overlap distance and may require either additional reflectors or cutting reflectors.

Figure 7. Assembly of 60 ft (18 m) Heat Exchanger System

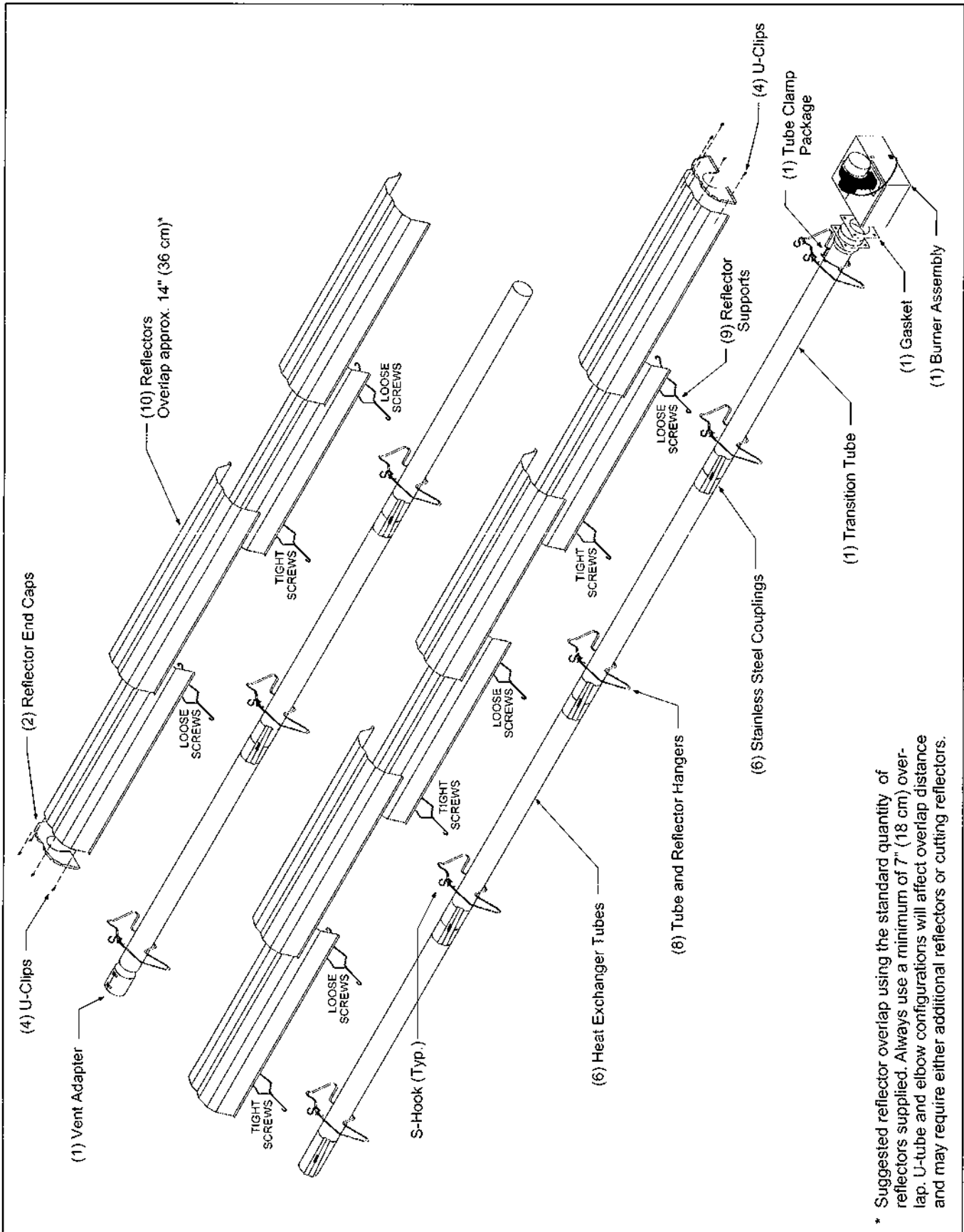

* Suggested reflector overlap using the standard quantity of reflectors supplied. Always use a minimum of 7" (18 cm) overlap. U-tube and elbow configurations will affect overlap distance and may require either additional reflectors or cutting reflectors.

Figure 8. Assembly of 70 ft (21 m) Heat Exchanger System

► Section 7. Component Installation

TUBE COUPLING INSTALLATION

Tube and tube fittings are connected by wrap-around couplings which clamp by means of a tapered, hammer-driven lock member.

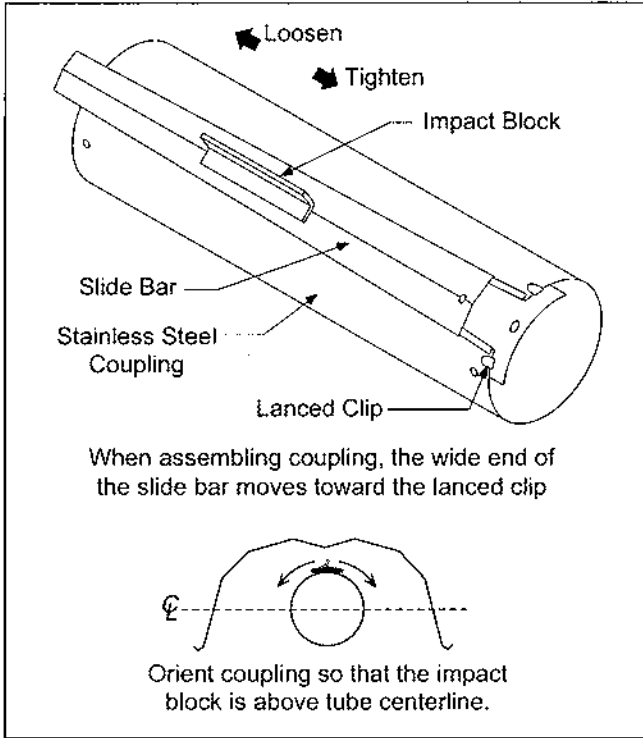

Figure 10. Coupling Assembly

To assemble the coupling, hook the free end of the coupling sleeve into the lanced clip. Place the wide end of the tapered slide bar on the coupling so that it moves toward the lanced clip. Insert the two tube ends into the coupling. Be sure the tube ends are in line and are flush against the stop pins inside the coupling.

Hammer-drive the slide bar until the coupling is secured snugly to the tubes. Overdriving the slide bar will distort the coupling or slide bar lip and will decrease the holding capability of the coupling. Coupling should be tight when the slide bar is $\pm 2"$ (5 cm) from the end of the coupling. See Figure 10.

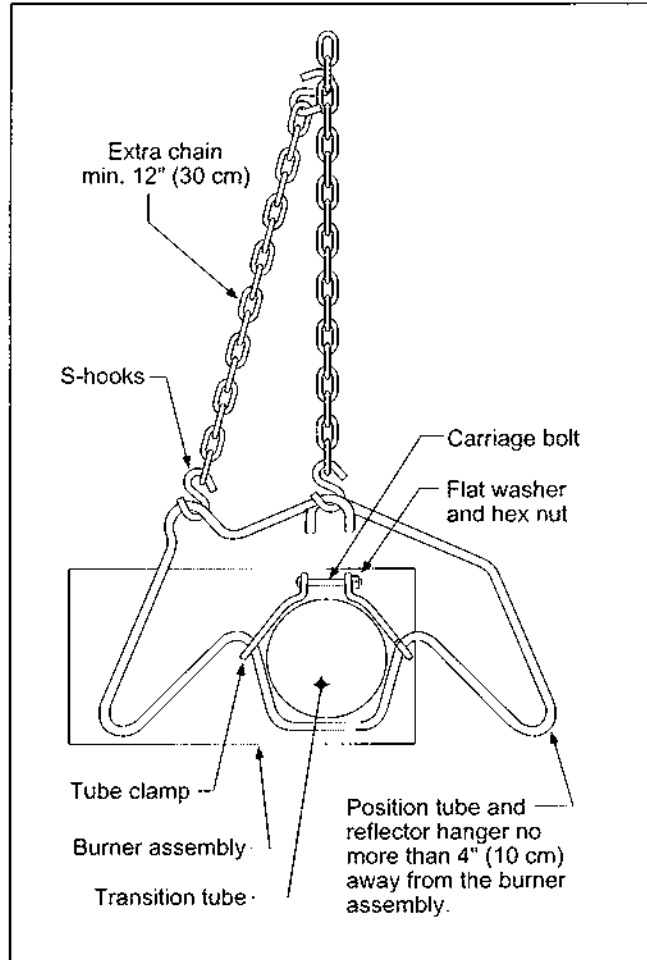

Figure 11. Tube Clamp Package

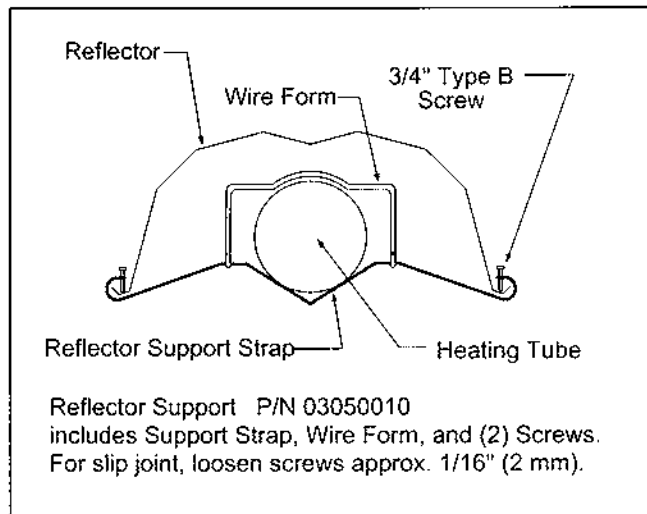

Figure 12. Reflector Support Package

ELBOW PACKAGE INSTALLATION

(P/N 02718702) Elbow Package includes: (1) elbow, (1) coupling, (1) end cap, (1) reflector joint piece, and (1) package of U-Clips. Install elbow into radiant tube sequence where plans indicate a 90° bend. Install reflector joint piece using the following procedure:

1. Flatten reflector edge where joint piece matches. Put a mark on the reflector, directly over the tube center. Center the accessory joint piece on the mark and scribe its contour on the reflector. Scribe the location of the mounting holes.
2. Cut away the reflector to clear the tube, leaving about one inch of material inside the scribed contour to attach the accessory joint. With an awl or other pointed tool, punch six 3/32" (2 mm) diameter holes in reflector in the positions shown in Figure 14.
3. Use six #10 sheet metal screws to attach the joint piece. Install a reflector end cap of the open end.

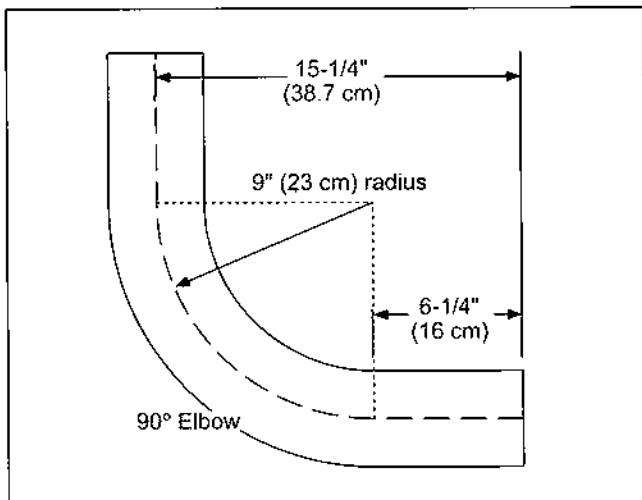

Figure 13. 90° Elbow Fitting Dimensions

REFLECTOR END CAP INSTALLATION

Reflector end caps must be installed over the open ends of reflectors. Attach the end cap to the reflector using a minimum of four U-clips per end cap.

Before installing the end cap, the center section must be removed. Carefully break the tabs on the bottom flange of the end cap first. Then gently flex the center section until it releases. Be very careful not to distort or otherwise damage the end cap during this procedure.

If the end cap is used at a joint piece to cover a 90° elbow or U-tube, the center section should not be removed.

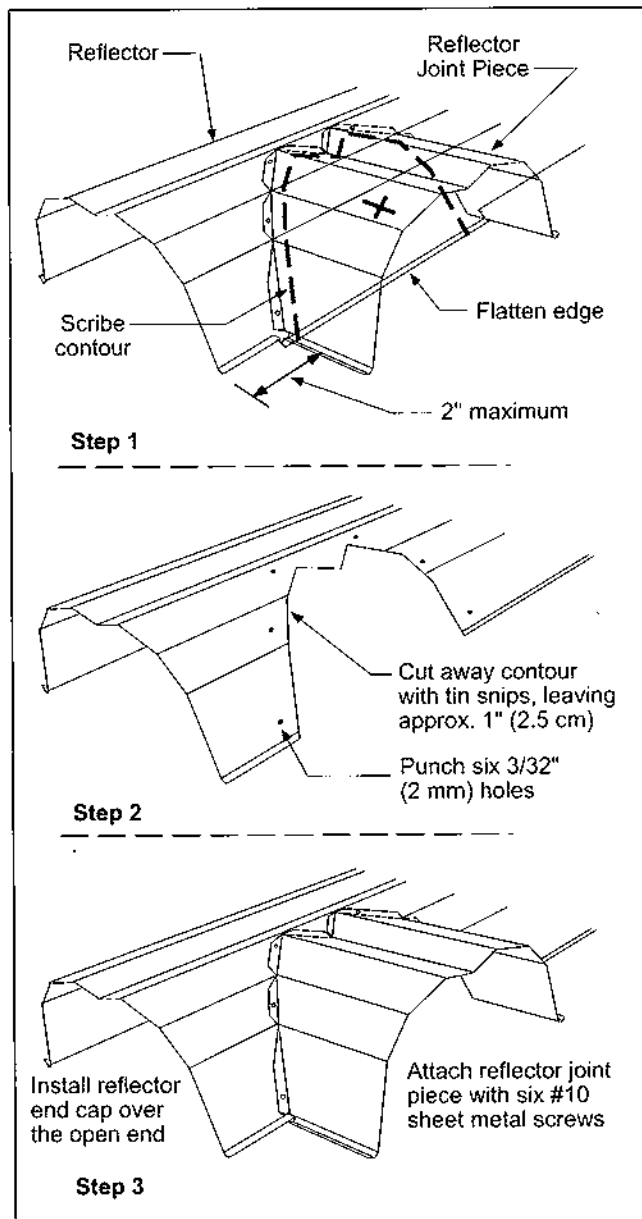

Figure 14. Reflector Joint Piece Installation

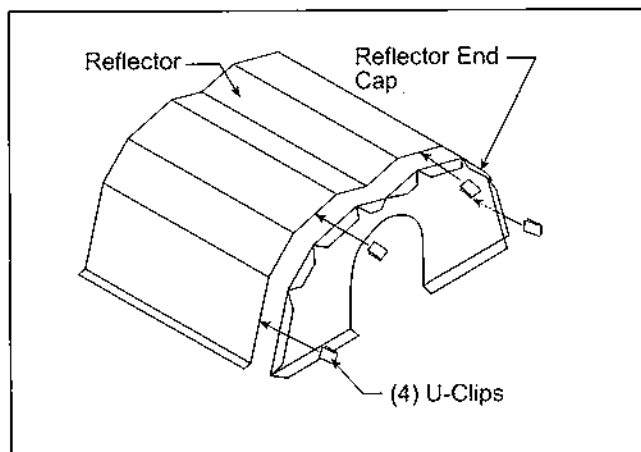

Figure 15. Reflector End Cap Installation

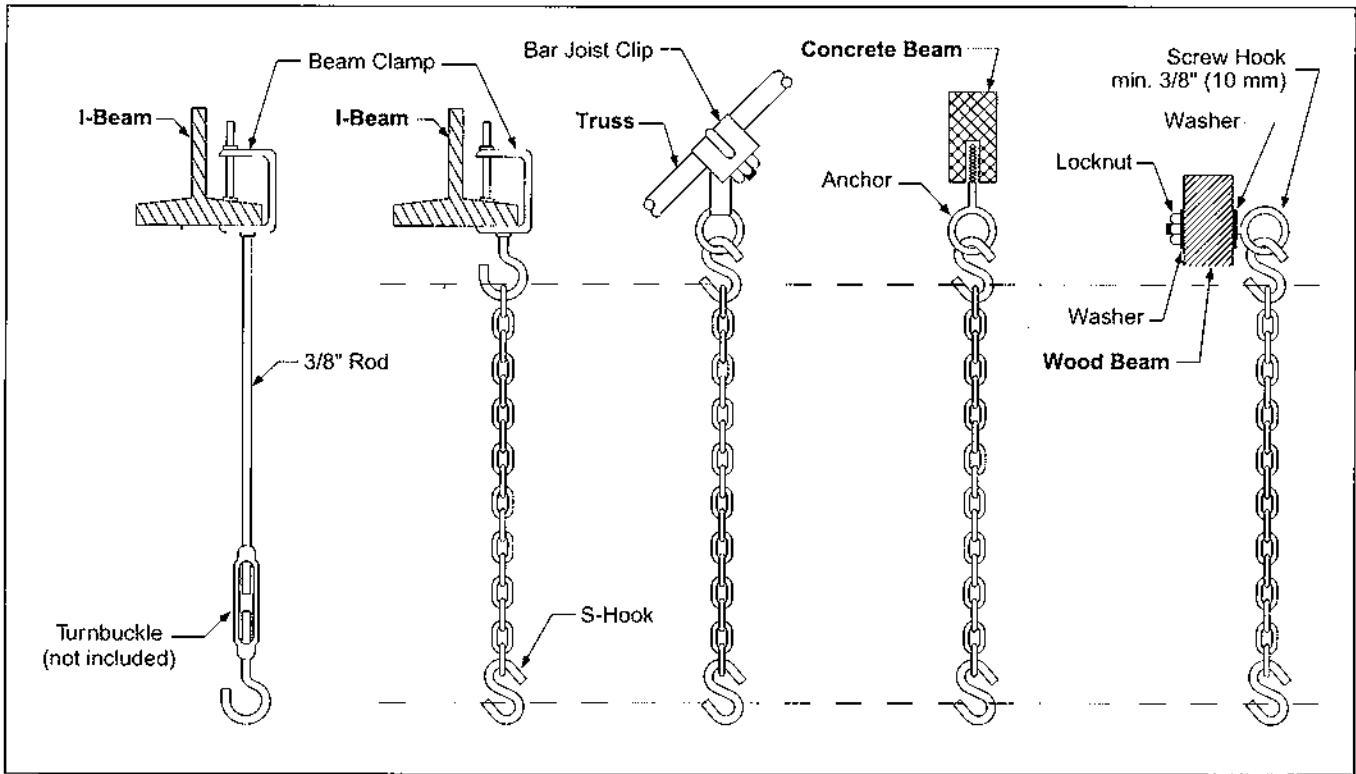

Figure 16. Typical Suspension Details

TURBULATOR INSTALLATION

For ease of installation, the turbulator should be installed in the tube before hanging the system. Use the following procedure (see Figure 17):

1. Assemble turbulator pieces by "twisting" matching ends together.
2. Insert a long wire (11 ft. minimum) down the length of the tube. Attach the wire to the hole in the tab on the adapter piece.
3. Using the wire, pull the assembled turbulator into the tube from the opposite end. Pull the turbulator through until just the tab comes out. Detach the wire.
4. Bend the tab around the tube. When installed the vent adapter will lock the tab in place.

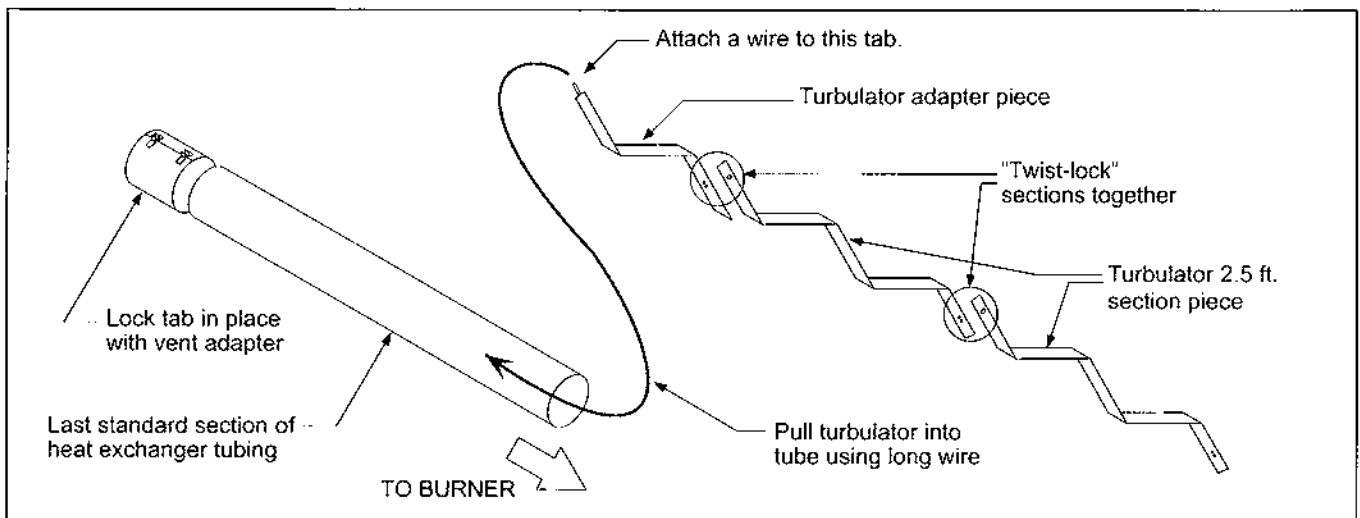

Figure 17. Turbulator Baffle Assembly Detail

SIDE EXTENSION REFLECTOR

Optional Side Extension Reflectors may be installed on either side of the unit. Each 8 ft. section of Side Reflector should match a reflector and have identical overlap to adjacent reflectors. Provide slip joints in the same locations as the reflectors. Proceed as follows (see Fig. 18):

1. Attach a reflector side extension support bracket to the tubes where needed. These brackets should be located adjacent to the overlapped joints of the reflectors.
2. Insert lower edge of reflector side extension in extension support bracket.
3. Cut suitable relief notches where the side extension reflector meets tube and reflector hangers and reflector support brackets.
4. Hook the top edge of the side extension reflector over the edge of the reflector.
5. A slip joint must be provided in the perimeter side extension at the location of each slip joint in the reflector. The overlap should be the same as the reflector.
6. Where severe air movement may be encountered, as at large door, one or two sheet metal screws should be used to attach the side extension reflectors together. Additional reflector supports are also recommended.
7. To Install the Retainer Clips: Lay bracket over the side extension reflector and standard reflector at the selected location. By using the hole in the clip as a template, drill or punch a 3/32" (2 mm) diameter pilot hole in the standard reflector. Secure the retainer clip using #8 x 3/8" sheet metal screws.

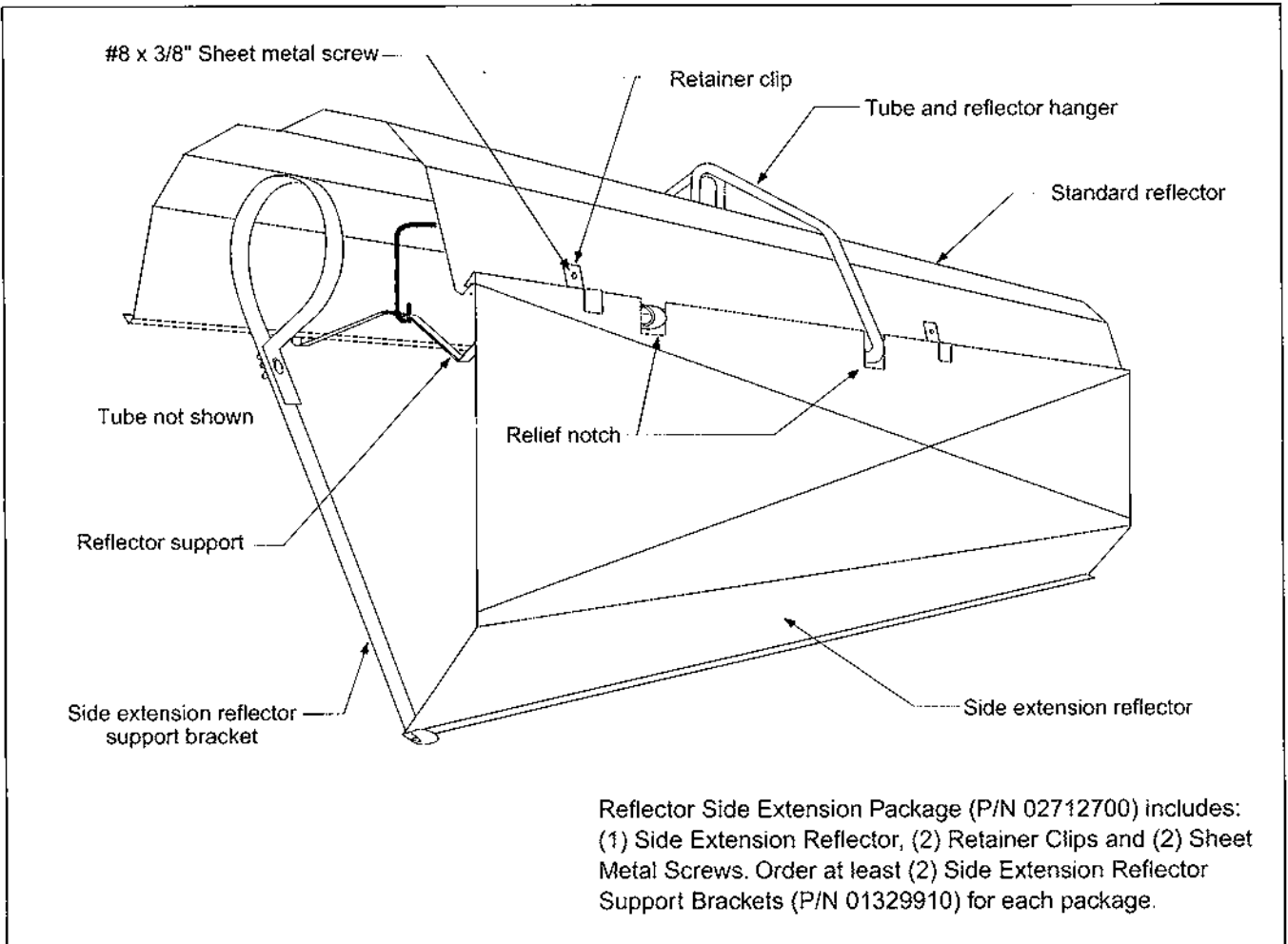

Figure 18. Installation of Side Extension Reflectors

U-TUBE PACKAGE

BH heaters (except BH-40) are approved for optional U-Tube configurations. The U-Tube Package (P/N 03011000) includes: (1) 180° U-Tube, (1) Plain Coupling, (1) Tube and Reflector Hanger, (2) End Caps, (1) U-Tube Support Bracket and (2) 4" (10 cm) U-Bolts with Lock washers and Hex Nuts.

Shown below is an example BH-100 U-Tube configuration. One of the 10 ft. (3 m) tubes was cut in half to balance the sides. (The layout does not need to be symmetrical.) One (1) additional coupling was needed to complete the installation. The U-Tube may be installed in either a standard horizontal position or in an opposite 45°

position as shown below. When designing a U-Tube configuration, the following rules must be adhered to:

1. A minimum of 10 ft. (3 m) on BH-60/80 and a minimum of 15 ft. (4.5 m) on BH-100/125/150/175/200 is required between the burner and the U-Tube.
2. The correct turbulator must be installed in the last standard section of heater tube.
3. The burner must never be operated in a tilted position.
4. The heater must be properly supported at all locations.

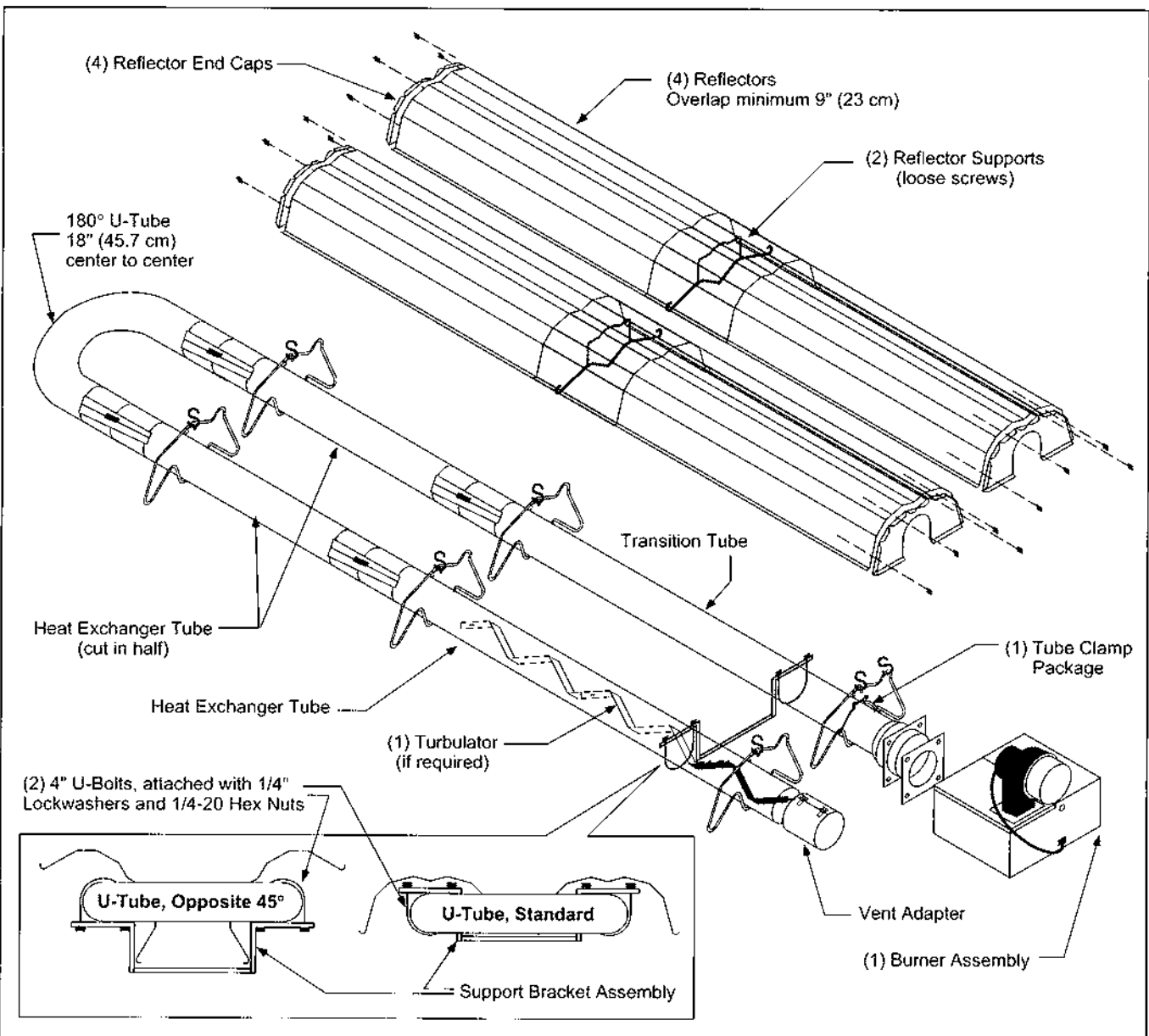

Figure 19. U-Tube Package Assembly Overview (optional)

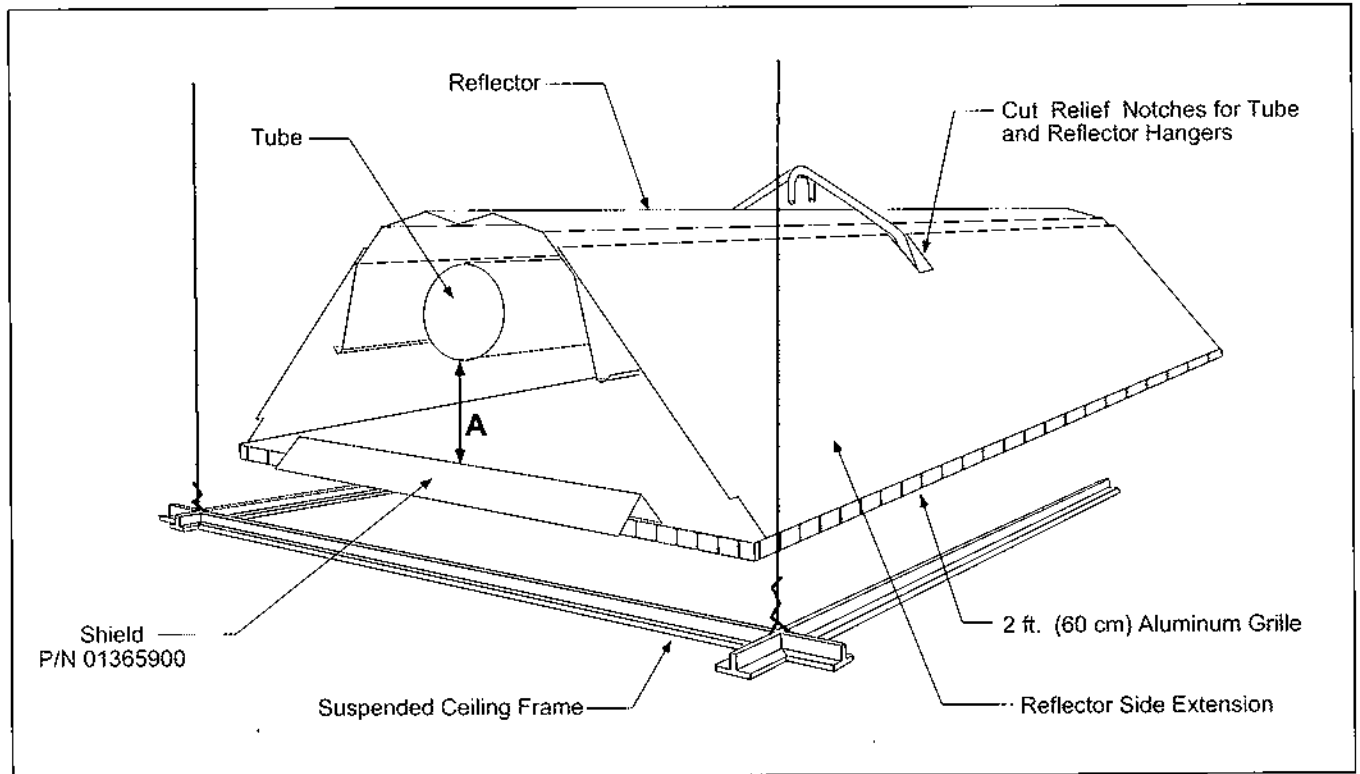

Figure 20. Installation of 2 ft. (60 cm) Decorative Aluminum Grille (optional)

DECORATIVE GRILLE INSTALLATION

▲ WARNING	
	Cut Hazard
	Wear protective gloves when handling aluminum grille.
	Edges are sharp. Failure to follow these instructions will result in injury.

When running the heater over a suspended ceiling, decorative grille must be used directly below the heater. The use of regular ceiling tiles directly below the heater will create an unsafe condition.

The decorative grille option allows the heater to be installed over suspended ceilings. The aluminum grille (P/N 91407000) comes in standard 2 ft. x 4 ft. (60 cm x 120 cm) sections and is installed in place of ceiling tile.

The system is hung in a normal fashion with the tube suspended over the grille at a height between 1 5/8" and 14 3/8" (between 4 cm and 36.5 cm). To select the appropriate side extension reflectors, calculate the distance "A" between the radiant tube and the decorative grille. See Table 4 below.

Shields (P/N 01365900) must be placed over ceiling frame members that pass underneath the heater. The side extension reflectors are available in standard 4ft. (120 cm) sections and have notches in the bottom corners to accommodate suspension system. Lay the side extension reflectors along the standard reflectors and cut suitable notches for the tube and reflector hangers where appropriate. It is generally not necessary to cut notches for the reflector support straps. Gloves should be worn when handling the aluminum grille to protect hands from sharp edges.

Table 4. Side Extensions for Decorative Grille

Distance "A"		Extension	
Minimum	Maximum	Part No.	Width
1.6" (4.1 cm)	5.8" (14.6 cm)	01370408	8" (20 cm)
5.8" (14.6 cm)	10.1" (25.7 cm)	01370412	12" (30 cm)
10.1" (25.7 cm)	14.4" (36.6 cm)	01370416	16" (40 cm)

► Section 8. Venting and Ducting

▲ WARNING	
	Carbon Monoxide Hazard
	Unvented heaters must be interlocked with sufficient building exhaust.
	Vented heaters must be vented outdoors.
	Unvented and vented heaters must be installed according to Installation Manual.
Failure to follow these instructions will result in death or injury.	

Heater must be vented in accordance with the proper national and local codes. Partial information relating to these specifications is provided in this section with regard to size and configurations for venting arrangements. United States: refer to ANSI Z223.1 - latest revision. Canada: refer to CAN/CGA-B149.1 and B149.2

Heater may be vented one of the following ways:

Unvented (with adequate ventilation)	pg. 25
Horizontal Venting - Combustible walls	pg. 25
Horizontal Venting - Noncombustible walls	pg. 25
Common Sidewall Venting	pg. 25
Vertical Venting	pg. 26
Common Vertical Venting	pg. 27

The method chosen will depend upon a number of factors including: building ventilation, available access points in walls and ceiling, number of burners installed, installation

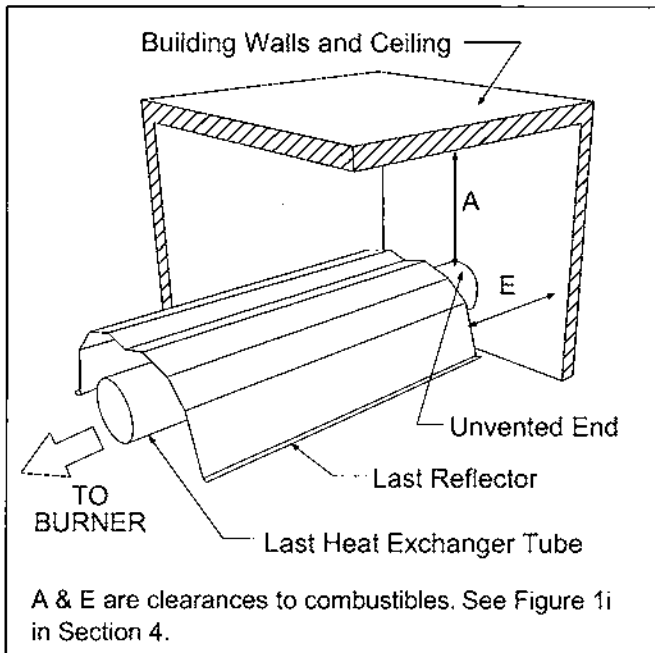

Figure 21. Unvented Operation

codes, etc. Consult layout drawing for venting method used. Some installations may require the use of an outside combustion air supply. See page 28 for details.

General Venting Requirements

Use the following guidelines to help insure an adequate, safe venting arrangement:

NOTE: Condensate may develop when long vent pipes are used. It is therefore recommended that the flue pipe length should be less than 20 feet (6 m).

- a) Exhaust end of heater will accept a four inch vent pipe using the vent adapter (P/N 90502700). Install the vent adapter with the seam on top. This will prevent condensation from leaking out of the adapter.
- b) Vent terminal opening must be beyond any combustible overhang.
- c) If condensation in the vent is a problem, the vent length should be shortened or insulated.
- d) For outside air installations, the outside air terminal must not be installed more than one foot above the vent terminal.
- e) Secure all joints with minimum (3) #8 x 3/8 sheet metal screws
- f) All vent joints should be sealed using suitable product such as General Electric RTV106 or Permatex Form-a-Gasket red high temperature silicone adhesive sealant.

Vent Length Requirements

- a) Maximum vent length allowed is 45 ft. (13.7 m)
- b) Maximum outside air supply duct allowed is 45 ft. (13.7 m)
- c) Vent length plus outside air supply length plus extension package shall not exceed 65 ft. (19.8 m).
- d) Under length conditions a) through c) above, a total of 2 elbows are allowed for vent and outside air supply together. Subtract 15 ft. (4.6 m) per additional elbow from maximum length allowed if more than 2 elbows are used.

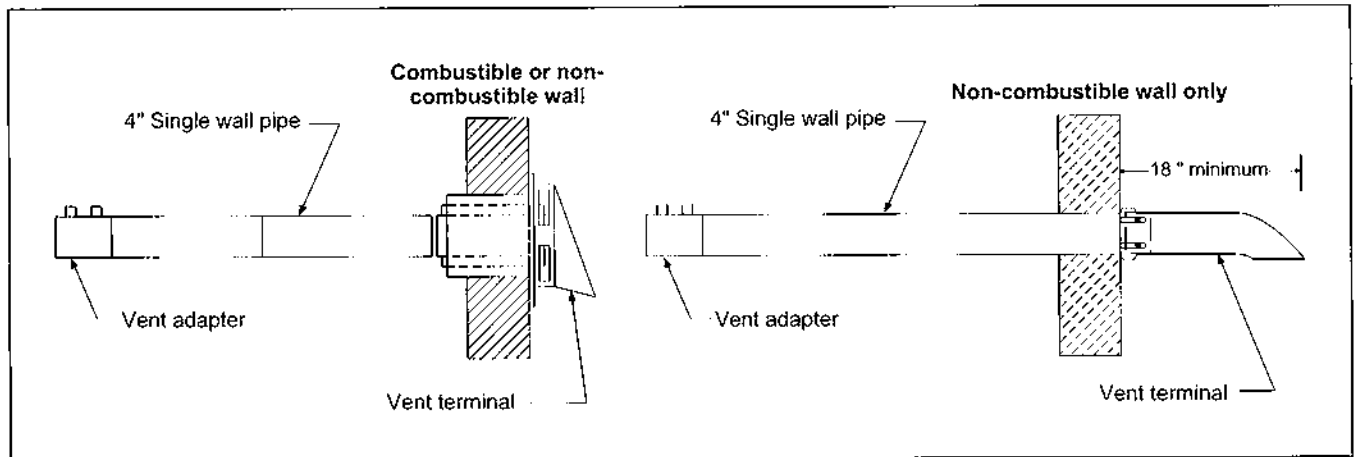

Figure 22. Horizontal Venting Configurations

UNVENTED OPERATION

- Sufficient ventilation must be provided in the amount of 4 cfm per 1000 BTU/hr firing rate (**United States**); 3 cfm per 1000 BTU/hr firing rate (**Canada**).
- Use of optional outside combustion air is not recommended with unvented heaters due to pressure considerations.
- If exhaust fans are used to supply ventilation air, an interlock switch must be used to prevent the heater from coming on when the fans are off. This may be done using an air pressure switch.
- For additional information: **United States**: refer to ANSI Z223.1 - latest revision (NFPA No. 54) and local codes; **Canada**: CAN/CGA-B149.1 and B149.2 Installation Codes.

HORIZONTAL VENTING (See Figure 22)

- In combustible or noncombustible walls use insulated vent terminal (P/N 90502100, Tjernlund VH1-4 or equivalent). Follow vent manufacturer's instructions for proper installation.
- For noncombustible walls only, use vent terminal (P/N 02537800)
- 4" O.D. vent pipe is required, 30 ft. (9 m) maximum length is recommended. Up to 45 ft. (13.7 m) maximum may be used if insulated to prevent excess condensation.
- Vent terminal should be installed at a height sufficient to prevent blockage by snow. Building materials should be protected from degradation by vent gases.

Requirements (United States)

- Vent must exit building not less than seven feet above grade when located adjacent to public walkways.

- Vent must terminate at least three feet above any forced air inlet located within ten feet.
- Vent must terminate at least four feet below, four feet horizontally from, or one foot above any door, window, or gravity inlet into any building.
- Vent terminal shall be located at least 1 ft. (30 cm) from any opening through which vent gases could enter a building.

Requirements (Canada)

- Vent terminal must not be installed less than 3 ft. (1 m) from any building opening.
- Vent must be at least 6 ft. (2 m) from the combustion air opening of this unit or any other appliance.
- Vent terminal must be installed at least 3 ft. (1 m) above grade.

COMMON SIDE WALL VENTING (See Figure 23)

Requirements

- Maximum of two units may be vented together into a 6" diameter common vent.
- Units must be of the same BTU input.
- Units must be controlled from one common thermostat.
- Use a sweeping tee, or sweeping Y connection. These connections may be purchased from any sheet metal fitting manufacturer. Drawings for these connections are available from Roberts-Gordon upon request.

Recommendations

Although not compulsory, an outside air supply to the burners is recommended.

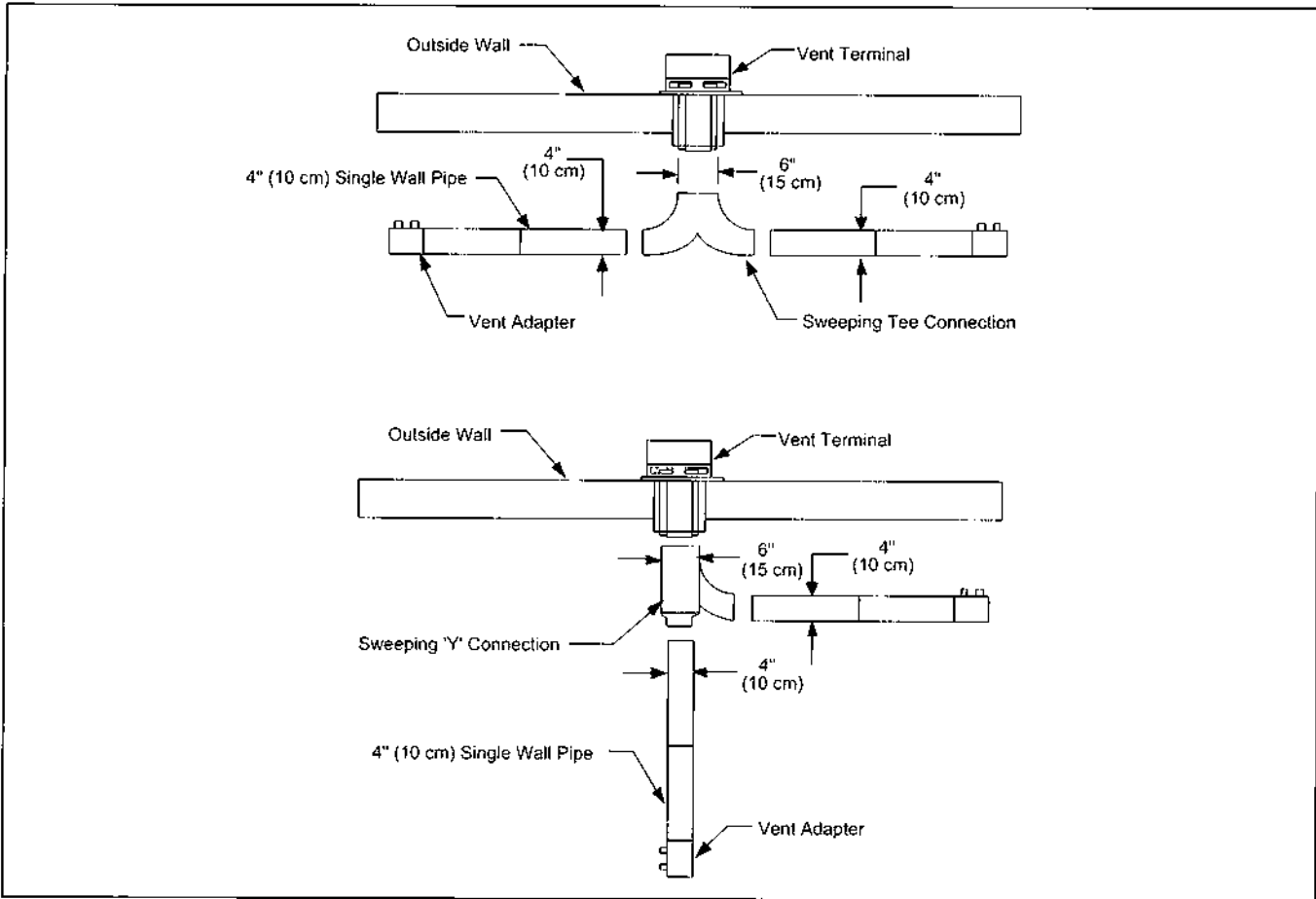

Figure 23. Common Side Wall Venting (Top View)

VERTICAL VENTING (See Figure 24)

- a) In the United States refer to ANSI Z223.1 - latest revision, (NFPA No. 54) for venting guidelines
- b) in Canada refer to CAN/CGA-B149.1 and B149.2 for venting guidelines.
- c) Type "B" minimum vent materials must be used outdoors.
- d) An insulating thimble may be required to pass through combustible structures.
- e) 4" O.D. vent pipe, maximum 45 ft. (13.7 m) in length may be used as shown above with an approved vent cap.

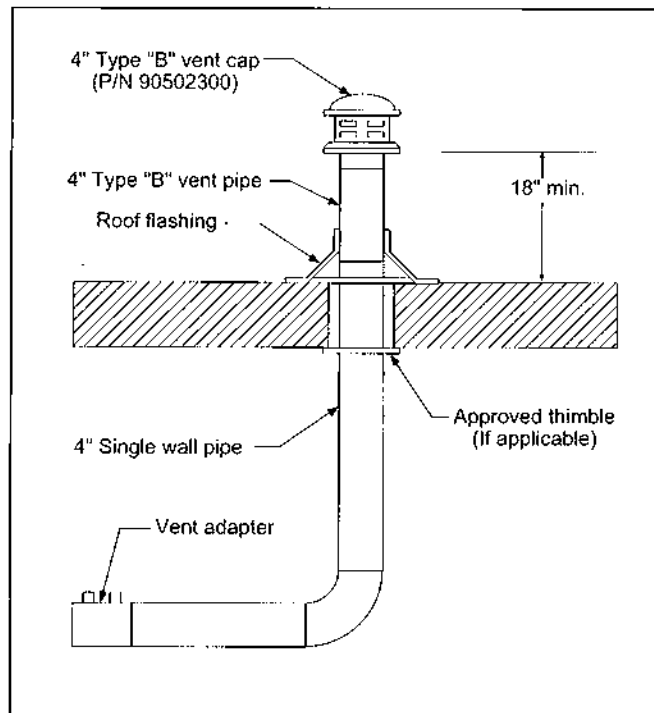

Figure 24. Vertical Venting Configuration

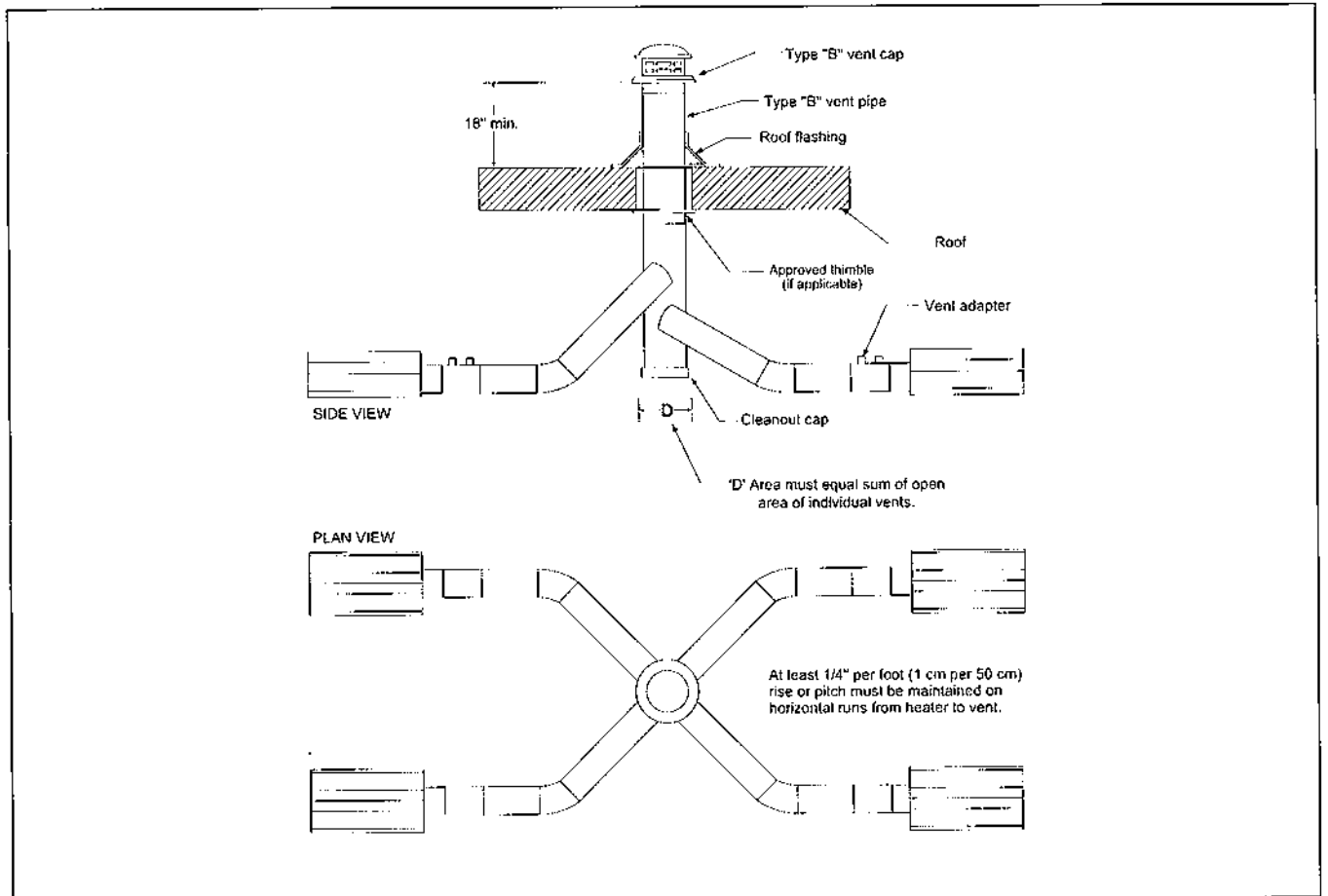

Figure 25. Common Vertical Venting

Common Vertical Venting (See Figure 25)

- a) Open area of common vent must equal the sum of the open area of individual vents connected to it.
- b) Heaters sharing a common vent must be controlled by the same thermostat.
- c) Connections to common stack must be positioned to avoid direct opposition between streams of combustion gases.

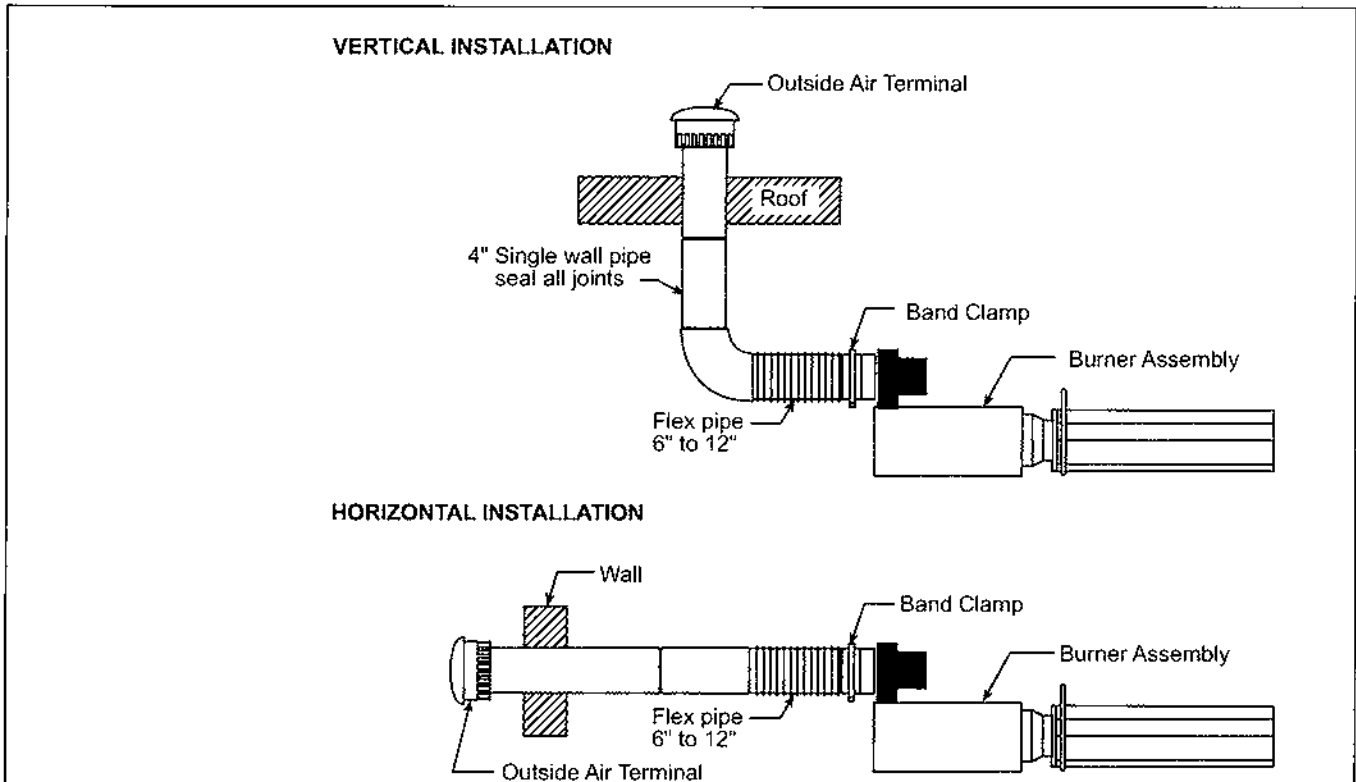

Figure 26a. Non-Pressurized Outside Air Supply

OUTSIDE COMBUSTION AIR SUPPLY

IMPORTANT: If the building has a slight negative pressure or contaminants such as halogenated hydrocarbons are present in the air, an outside combustion air supply to the heaters is strongly recommended.

The BH heater is approved for installation with an outside air supply system.

For an outside air supply, a 4" O.D. (10 cm O.D.) single wall pipe may be attached to the heater. The duct may be up to 45 ft. (13.7 m) maximum length or 2 ft. (60 cm) minimum length with no more than 2 elbows. See Vent Length Requirements heading on pg. 24 for more detailed guidelines.

The air supply duct may have to be insulated to prevent condensation on the outer surface. The outside air terminal should be securely fastened to the outside wall by drilling four 1/4" (6 mm) diameter holes in the outside flange; wood screws or bolts and expansion sleeves may be used to fasten the terminal.

For the outside air terminal, use Metalbestos #31267 (R-G P/N 90502300), or ACME #104, or equivalent.

PVC pipe, aluminum flex duct, or equivalent, may be used instead of single wall pipe for the outside combustion air supply.

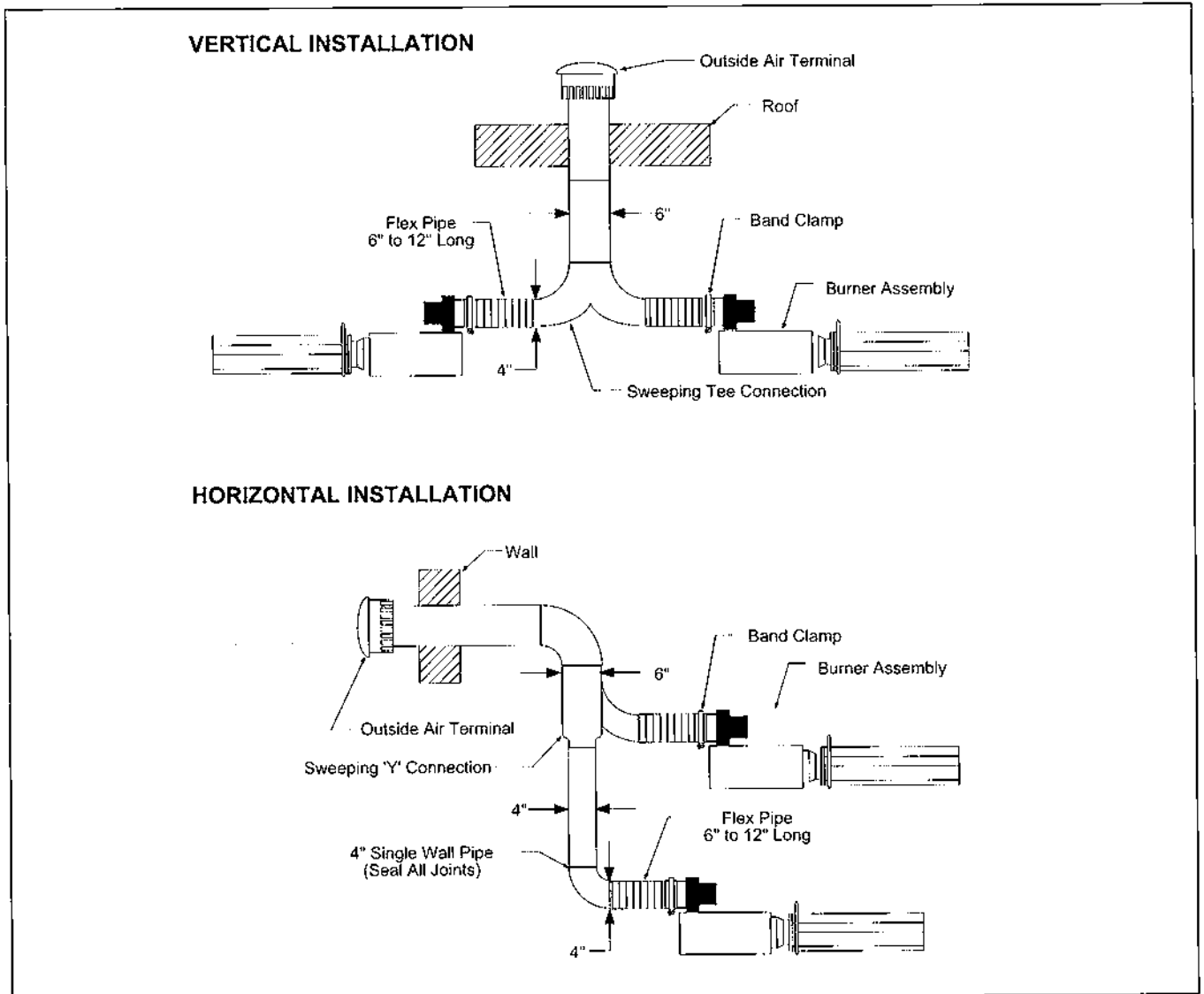

Figure 26b. Non-Pressurized Outside Air Supply for a Maximum of Two Heaters Controlled by a Common Thermostat

OUTSIDE COMBUSTION AIR SUPPLY (CONTINUED)



When air is supplied for combustion to a maximum of two heaters through a common duct, the following rules apply:

1. Follow the venting rules on pg. 24 for detailed guidelines.
2. The two units must be controlled by a common thermostat.
3. Use 4" O.D. (10 cm O.D.) single wall or PVC pipe between the heater connection and the common source. The common source will be a minimum of 6" O.D. single wall or PVC pipe.

4. Combined length of the 4" and 6" pipe shall not exceed 45 feet (13.7 m) with 2 elbows maximum per unit (see Fig. 26b). See also Vent Length Requirements heading on pg. 23 for more detailed guidelines.
5. Entry of the 4" pipes will not oppose one another.

Example: 4 feet of 6" O.D. (15 cm O.D.) common supply air pipe and one 6"x4"x4" tee are attached to 4" pipe x 4 feet long, attached to CTH2 units. This will limit the flue length to 45 feet of 4" pipe.

► Section 9. Gas Piping

	
Fire Hazard	Explosion Hazard
<p>Connect gas according to Figure 27.</p> <p>Gas line moves during operation.</p> <p>Failure to follow these instructions will result in death, injury or property damage.</p>	<p>Do not high pressure test the gas piping with the burner connected.</p> <p>Failure to follow these instructions will result in death, injury or property damage.</p>

There is an expansion of the radiant pipe with each firing cycle, and this will cause the burner to move with respect to the gas line. This can cause a gas leak resulting in an unsafe condition if the gas connection is not made strictly in accordance with Figure 27 of these instructions.

Read applicable warnings in Section 1 before proceeding with Gas Piping installation. Improper installation may result in death, severe injury or property damage.

Meter and service must be large enough to handle all the burners being installed plus any other connected load. The gas line which feeds the system must be large enough to supply the required gas with a maximum pressure drop of 1/2" w.c. When gas piping is not included in the layout drawing, the local gas supplier will usually help in planning the gas piping.

A 1/2" gas supply connection at each burner location must be located and oriented as shown in Figure 27. To check system pressure, put a plugged 1/8" NPT tapping in the gas line at the connection to the burner furthest from the supply. Before connecting the burners to the supply system, verify that all high pressure testing of the gas piping has been completed.

Follow these instructions to ensure a professional gas supply system installation:

- Support all gas piping with suitable pipe hanging materials.
- Use wrought iron or wrought steel pipe and malleable iron fittings. All pipe and fittings should be new and free from defects. Carefully ream the pipe and tubing ends to remove obstructions and burrs.
- Use LP-gas-resistant joint compound on all threads.
- Check the pipe and tubing ends for leaks before placing heating equipment into service. When checking for gas leaks, use a soap and water solution; never use an open flame.

Install the flex gas connector as shown. The flex gas connector accommodates expansion of the heating system and allows for easy installation and service of the burner. A 90° pipe elbow (not supplied) must be installed on the pipe nipple to ensure proper orientation of the flex gas connector.

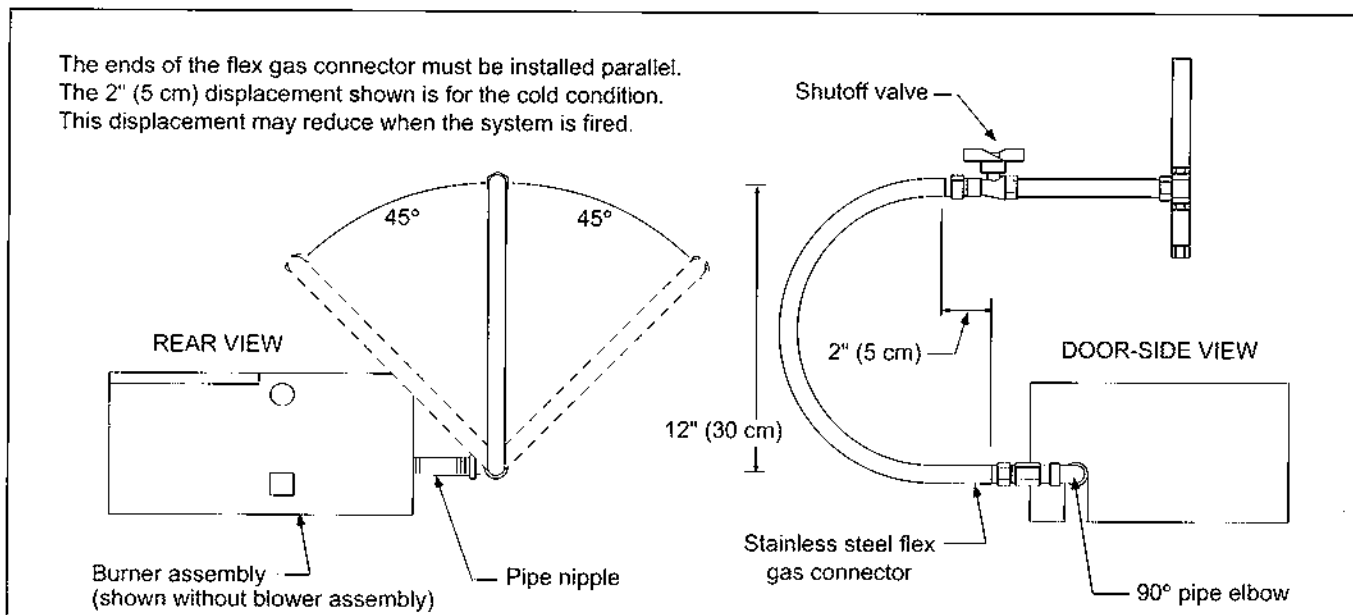

Figure 27. Gas Line Connection with Stainless Steel Flex Gas Connector

► Section 10. Wiring

⚠ WARNING	⚠ ATTENTION
<p>Electrical Shock Hazard</p> <p>Disconnect electrical power before servicing.</p> <p>Replace door before operating.</p> <p>Failure to follow these instructions will result in death or electrical shock.</p>	<p>Risque d'électrocution</p> <p>Débranchez le courant électrique avant toute révision.</p> <p>Remplacez la porte avant la mise en marche.</p> <p>Le non-respect de ces consignes peut entraîner mort ou électrocution.</p> <p style="text-align: right;">©P/N 91037901</p>

Heaters are normally controlled by thermostats. Line voltage thermostats are wired directly (see Figure 28); the recommended 24V thermostats use a relay (see Figure 29). Heaters may also be controlled with a manual line voltage switch or timer switch in place of the thermostat. Heaters must be grounded in accordance with applicable codes: **United States:** refer to National Electrical Code ANSI/NFPA 70 - latest revision **Canada:** refer to Canadian Electrical Code CSA C22.1 Part I - latest revision.

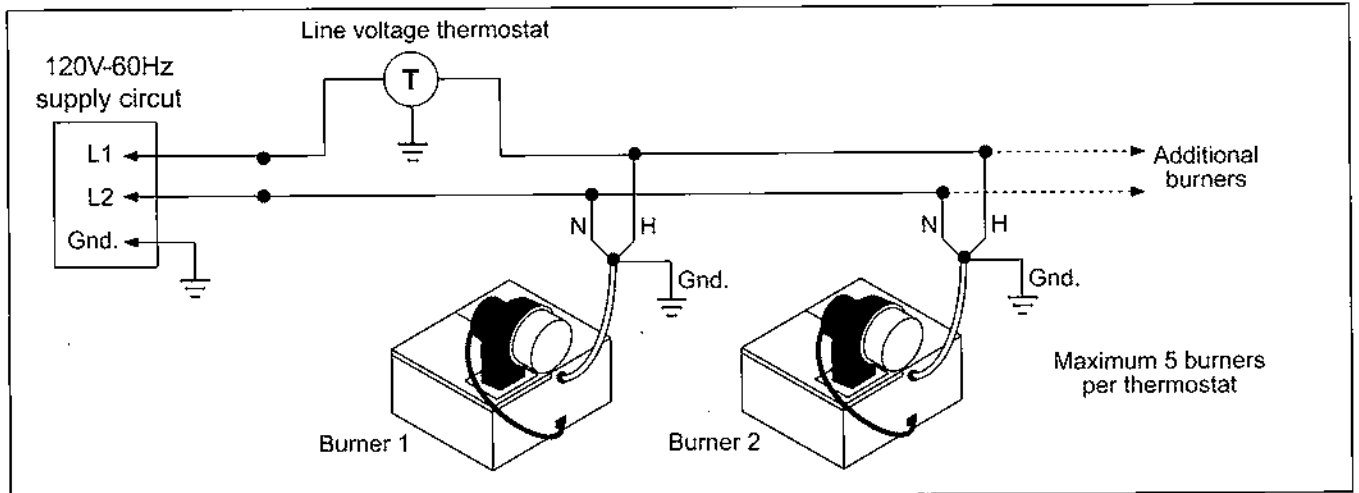

Figure 28. Line Voltage Thermostat Wiring

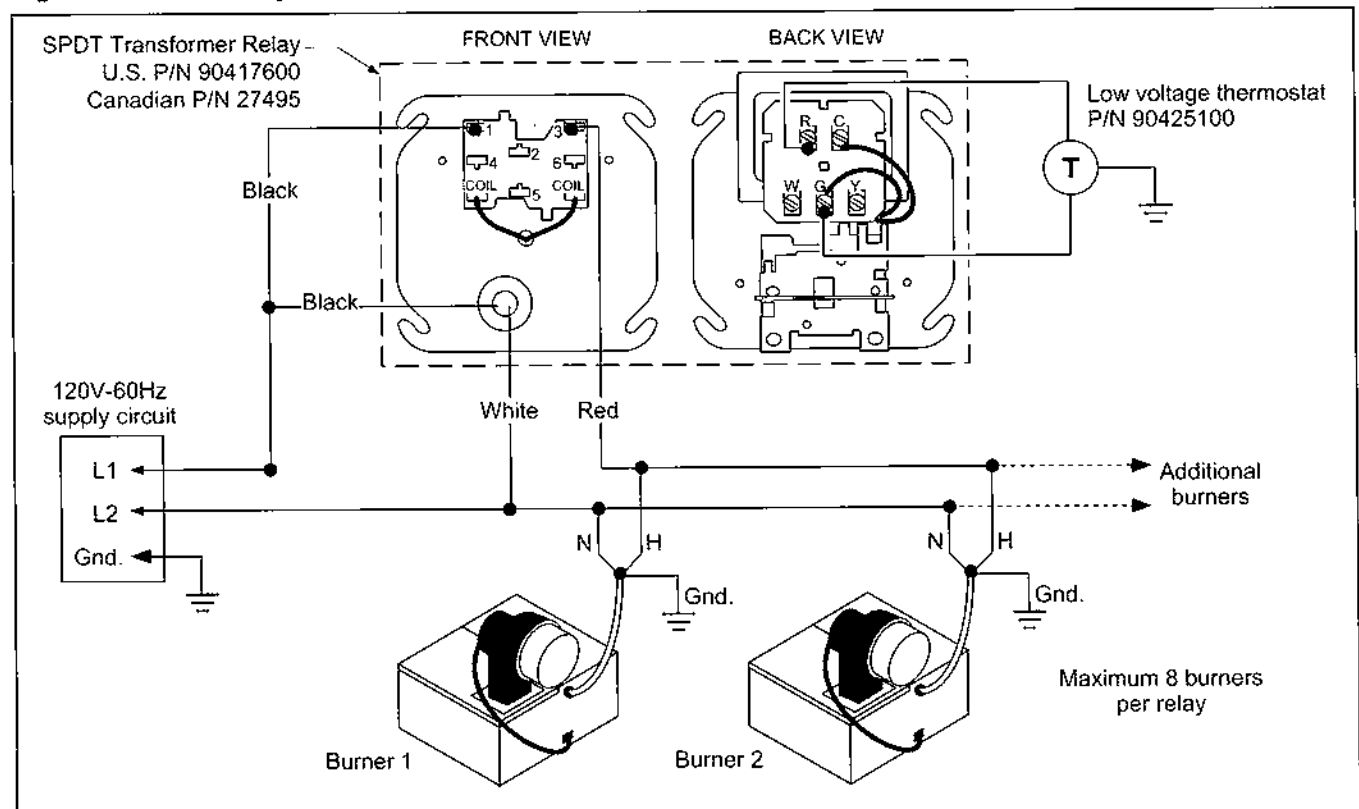

Figure 29. Low Voltage Thermostat and Relay Wiring

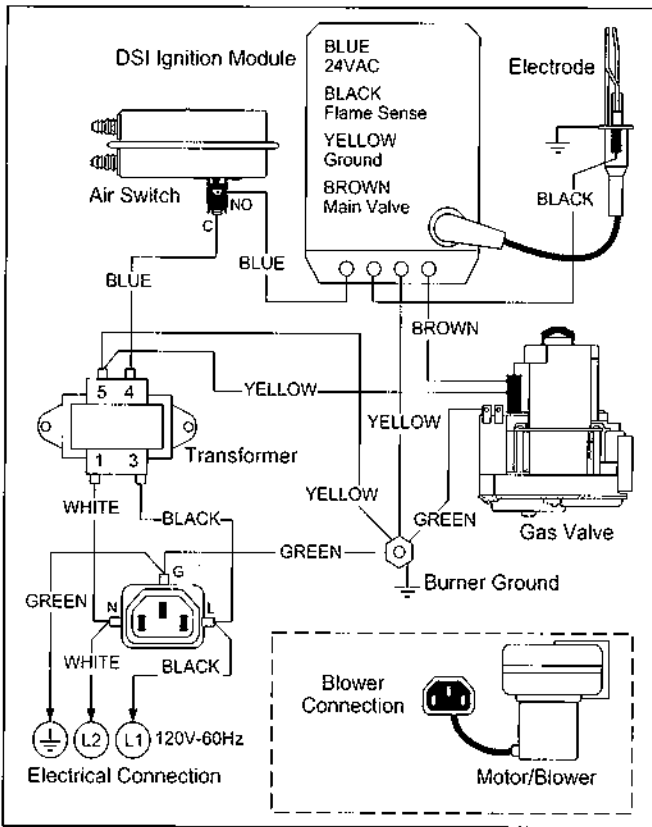

Figure 30. Burner Internal Wiring Diagram

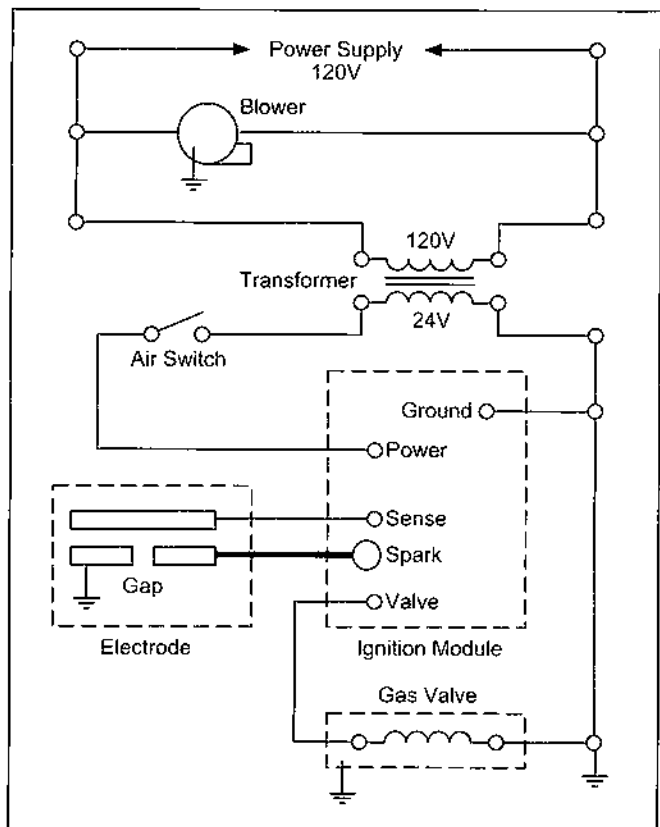

Figure 31. Burner Ladder Diagram

⚠ WARNING	⚠ ATTENTION
<p>If any of the original wire as supplied with the heater must be replaced, it must be replaced with wiring material having a temperature rating of at least 105°C and 600 volts.</p>	<p>Si une partie du câblage d'origine fourni avec le radiateur doit être remplacée, elle doit l'être par du matériel de câblage tolérant une température d'au moins 105°C et 600 volts.</p>
©/N 91038800	

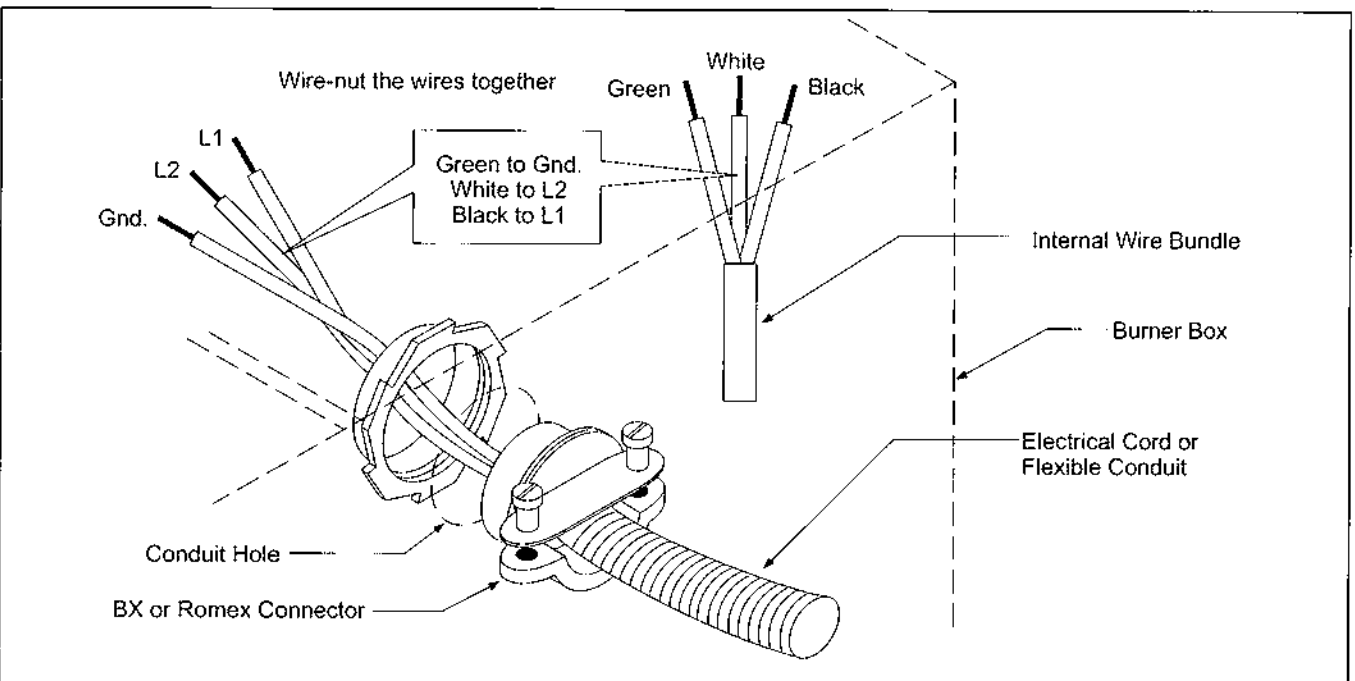



Figure 32. Electrical Connection to the Burner Box

► Section 11. Operation

▲ WARNING		▲ ATTENTION	
Fire Hazard		Risque d'incendie	
Do not remove door when operating heater.		Ne pas retirer porte lors du fonctionnement du radiateur.	
No user serviceable parts inside.		Ne contient aucune pièce révisable par l'utilisateur.	
Failure to follow these instructions will result in death, injury or property damage.		Le non-respect de ces consignes peut causer mort, blessures ou dommage matériel.	
©P/N 91037900			

The BH-Series heater is equipped with a direct spark ignition system.

Sequence of Operation

1. Turn the thermostat up. When the thermostat calls for heat, the blower motor will energize.
2. When the motor approaches nominal running RPM, the air proving switch closes and activates the ignition module.
3. The ignition module then opens the redundant gas valve and energizes the spark igniter.
4. When the flame is established, the sparking sequence ceases.
5. If the flame is not established during the ignition sequence, the ignition module closes the gas valve and purge begins. Module will try 2 additional times for ignition (with purge in between). If ignition is not established, the module will lock out.
6. If the flame extinguishes during operation, the ignition module will provide multiple trial sequence described in step 5. If ignition is not re-established, the module will lock out.

7. After lockout, control must be reset by turning down thermostat for five (5) seconds, and then raising it again to desired temperature, or by disconnecting power and then reconnecting.

8. When thermostat is satisfied, all power to the unit is shut off.

Maintenance

▲ WARNING	
Disconnect gas and electrical supplies before performing service or maintenance.	
Failure to follow these instructions will result in death, injury or property damage.	

For best performance, the following maintenance procedures should be performed before each heating season:

1. Check condition of blower scroll and motor. Dirt and dust may be blown out with compressed air, or a vacuum cleaner may be used.
2. Check condition of burner. Carefully remove any dust or debris from inside the burner box or mixing tube.
3. Inspect the electrode. Replace electrode if there is excessive carbon residue, erosion of electrodes or other defects. Gap should be 0.125".
4. Check the inside of the firing tube with a flashlight. If carbon or scale are present, scrape out the deposits with a wire brush or rod, or metal plate attached to a wooden pole.
5. Check the vent pipe for soot or dirt. After cleaning as necessary, re-attach the vent pipe to the heater.
6. Outside surfaces of heater reflector may be cleaned by wiping with a damp cloth.
7. A qualified service agency should be contacted for service other than routine maintenance.
8. Check vent terminal and fresh air inlet to see that they have not become blocked during the non-heating season. If either pipe is restricted, the air switch won't close, resulting in a no-heat situation.

► Section 12. Troubleshooting

▲ WARNING

Disconnect gas and electrical supplies before performing service or maintenance.

Failure to follow these instructions will result in death, injury or property damage.

No Power (Power supply connected)

1. Check to see that the thermostat is calling for heat.
2. Check fusing in electrical supply to heater.
3. Check for 120V at connection.

Blower Motor Fails to Run

1. Check for broken motor wire
2. Does blower wheel turn freely? Replace the motor if it is seized.

No Spark

1. Turn off gas and check for spark at the burner.
2. Ignition modules have a built-in pre-purge. Wait 45 seconds and try again.
3. Recycle thermostat or power if no spark appears.
4. Check for loose or broken leads.
5. Replace air switch if faulty.
6. Check electrode gap. Gap should be 0.125"
7. Make sure that the total length of outside air vent and vent pipe has not been exceeded.
8. Check the vent and vent terminal for obstructions.
9. Check the plastic tubing connecting the air switch. A hole in the line will prevent ignition.

No Gas Present

Gas pressure downstream of gas control can be measured by using a manometer and connecting to pressure tap on control.

1. Check to see if manual valve to heater is ON.
2. Check to see if manual valve knob on heater gas control is ON.
3. Supply gas pressure can be checked at 1/8" NPT pressure tapping on heater external manual valve.
4. Check to see if gas control is opening; no manifold pressure indicates valve is closed.

If the valve is closed, either the gas valve or the ignition module is faulty.

⚠ WARNING	
	Electrical Shock Hazard
	Do not disconnect ground leads inside heater.
	Do not interchange grounded and ungrounded leads on transformer or ignition module.
Failure to follow these instructions will result in death or electrical shock.	

Burner Lights and Then Goes Out

Flame current is the current which passes through the flame from the sensor to ground to complete the primary circuit. A minimum flame generated current, usually about 2.0µA is necessary to prevent lockout.

To measure flame current, disconnect the black sensor wire at the electrode and insert a 0-50µA DC meter in the circuit.

⚠ WARNING	
	Electrical Shock Hazard
	Disconnect electrical power before inserting meter into the circuit.
	Replace door before operating.
	Failure to follow these instructions will result in death or electrical shock.

Re-attempt ignition sequence and read flame current.

If insufficient flame current is present, inspect electrode and check electrical grounds. Repair as necessary.

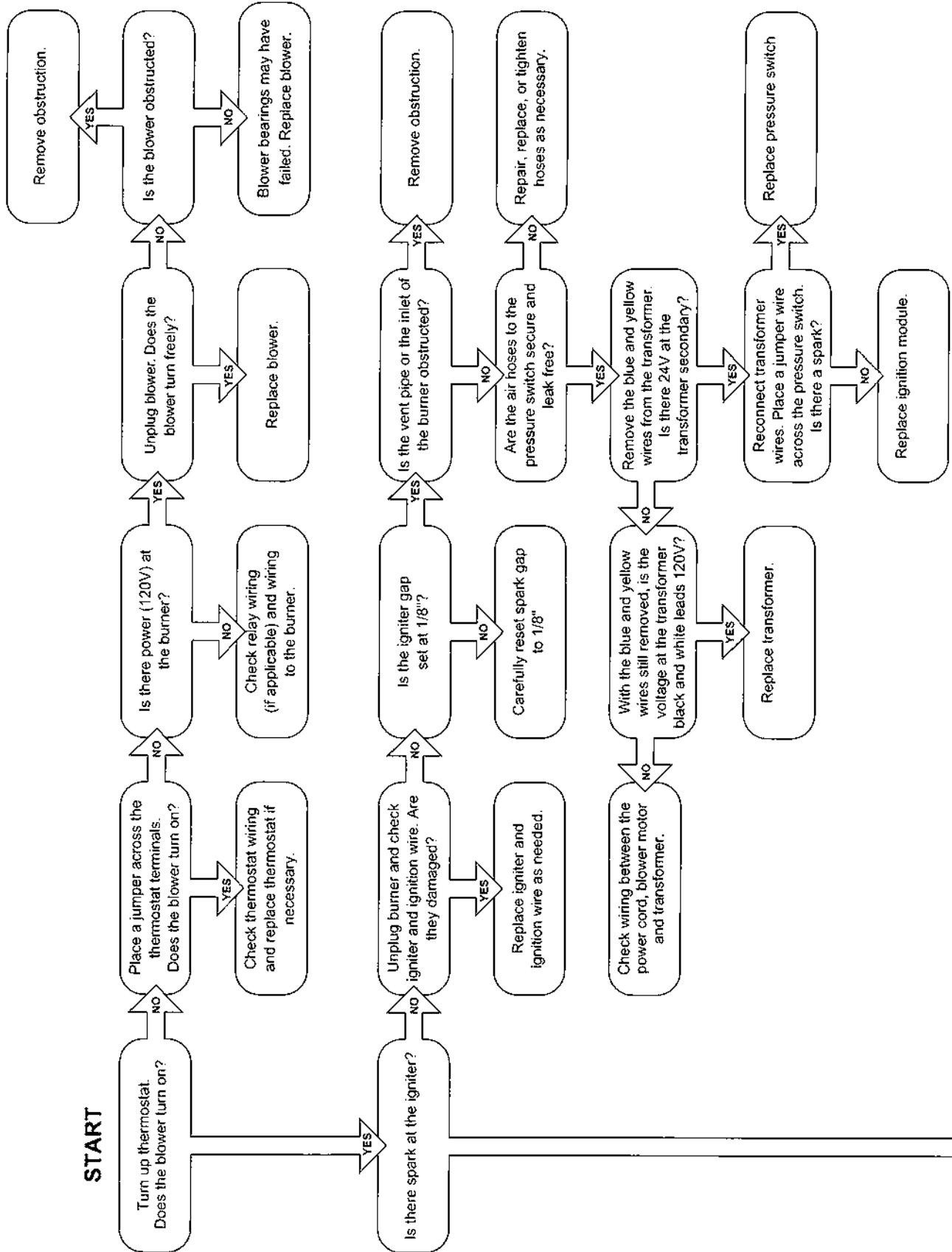
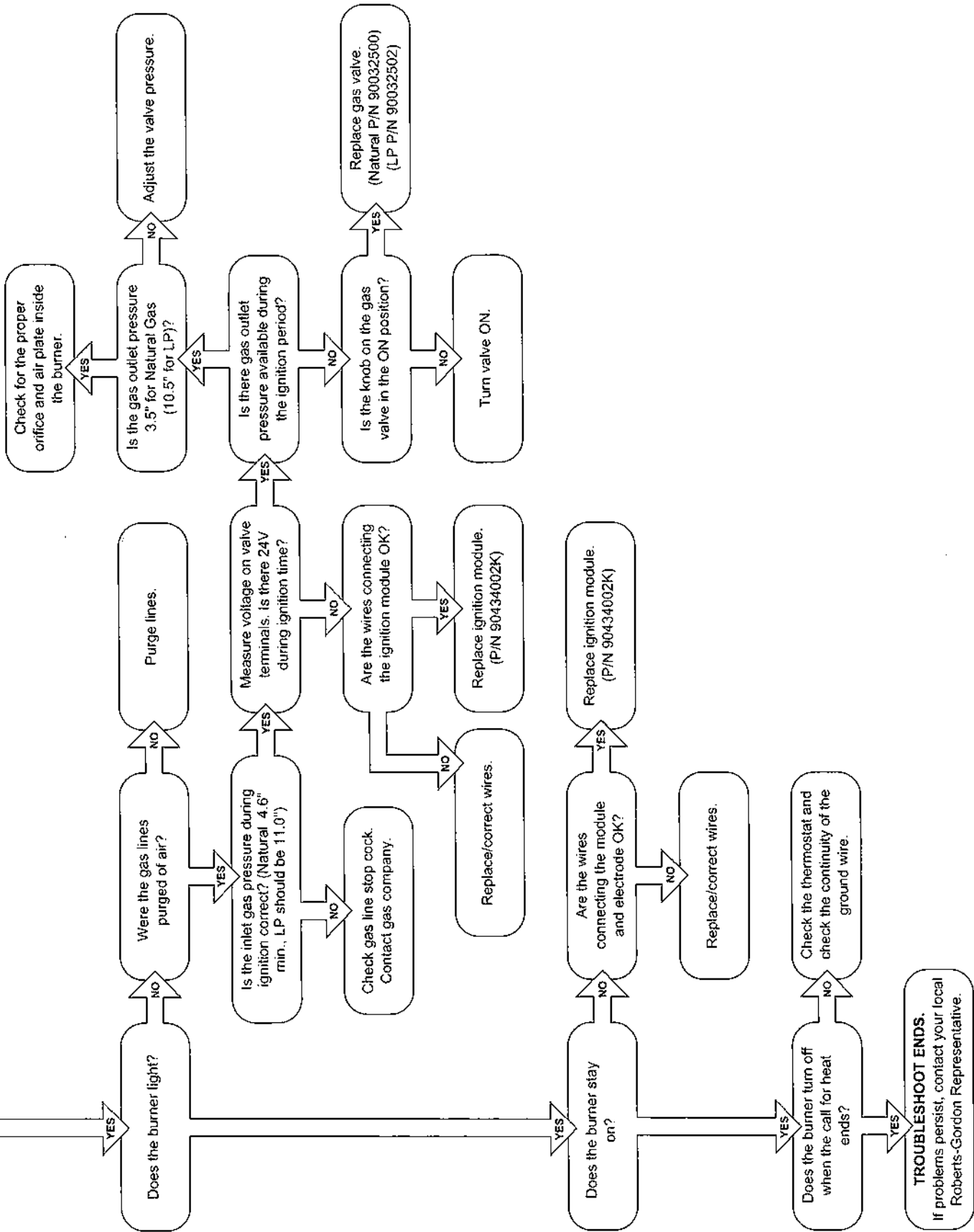

Figure 33. BH-Series Troubleshooting Flow Chart



► Section 13. Replacement Parts

Use only genuine Roberts-Gordon replacement parts.
Failure to follow these instructions will result in death,
injury or property damage.

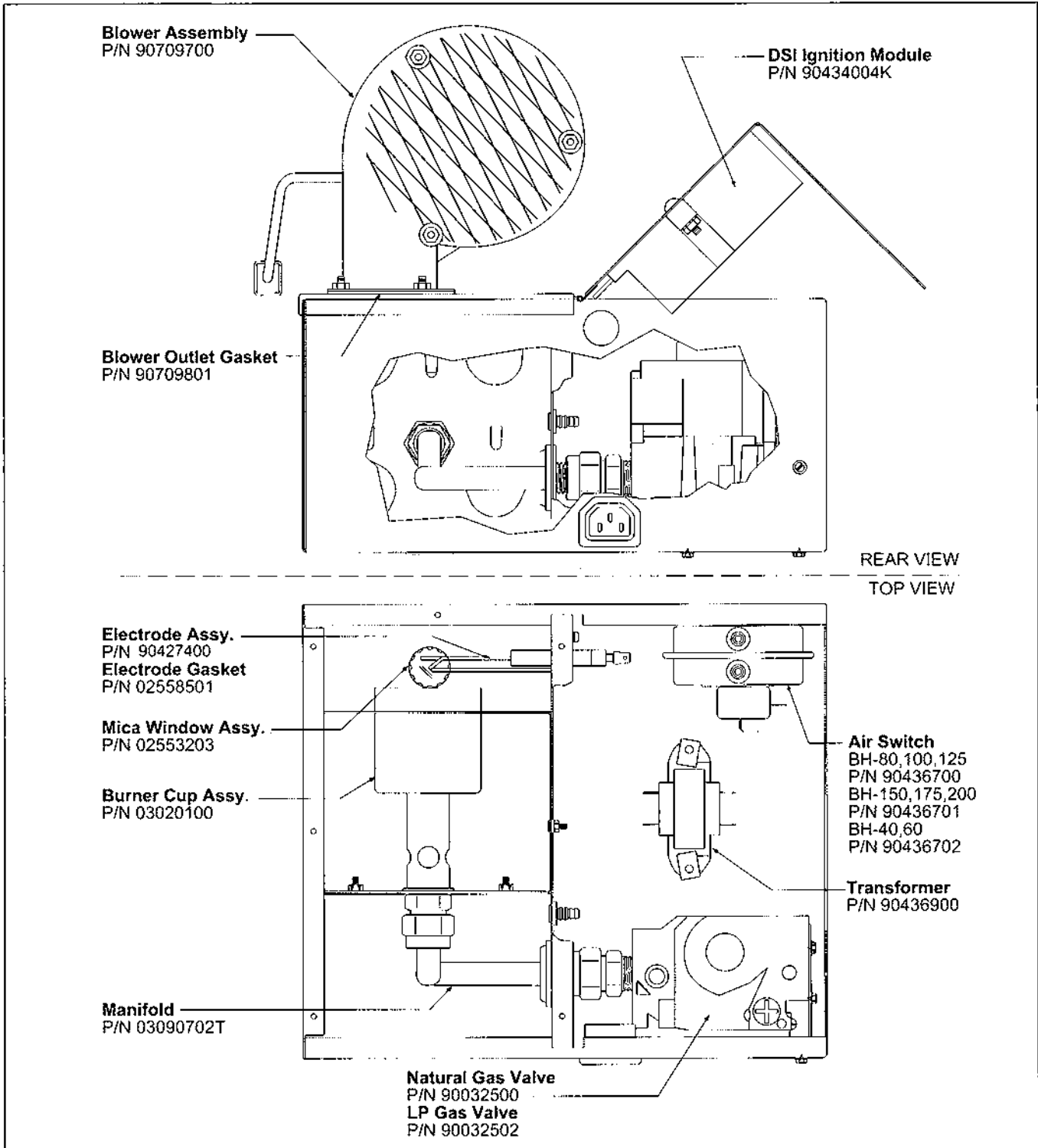

Figure 34. BH-Series Burner Replacement Parts

► Section 14. Engineering Specifications

The total heating system supplied shall be design certified by the American Gas Association and the Canadian Gas Association.

A. Burner and Burner Controls

1. Burners shall be capable of firing with one of the fuel options as specified on the purchase documents: Natural Gas or LP.
2. Burners shall be supplied to fire at any one of the input firing rates as specified:

BH-40	40,000 BTU/Hr.
BH-60	60,000 BTU/Hr.
BH-80	80,000 BTU/Hr.
BH-100	100,000 BTU/Hr.
BH-125	125,000 BTU/Hr.
BH-150	150,000 BTU/Hr.
BH-175	175,000 BTU/Hr.
BH-200	200,000 BTU/Hr.
3. Burner shall be equipped with fully automatic direct spark 100% shut-off ignition device. Power supplied to each heater shall be 120V, 60 HZ, single phase. Burners shall be rated for 1.0 Amp.
4. Burner shall be equipped with thermal overload motor protection, balanced air rotor, combustion air proving safety pressure switch, and viewing window for flame observation.
5. When specified, in contaminated environments, the burner shall be capable of supplying outside air to each burner for the support of combustion.
6. All burners shall be ready to accept field-installed flexible conduit for electrical power supply.
7. At customer's choice, burners may be controlled with either an optional line voltage thermostat or by optional low voltage thermostats with an appropriate low voltage transformer relay.
8. Gas supply to the burners shall be as follows:

1/2" NPT	(for BH -40, -60, -80, -100, & -125)
3/4"NPT	(for BH -150, -175 & -200)
Natural Gas:	4.6" W.C. MIN, 14"W.C. MAX 5.0" W.C. MIN for BH-175, BH-200
LP Gas:	11" W.C. MIN, 14.0" W.C. MAX

B. Heat Exchanger

1. Radiant tubing shall be 4" diameter, 16 gauge, aluminized steel first 10 feet, hot rolled steel remainder of unit (or when specified, all aluminized for entire radiant tube length). Sections shall be joined with stainless steel wrap-around couplings.
2. Reflector to be of aluminum material and designed to direct all radiant output below horizontal centerline of radiant tube. Reflectors shall be certified for 0° or 45° mounting.
3. Reflectors shall have end caps to prevent heat loss due to convection.
4. Steel turbulators to be used as specified for even heat distribution.
5. Heater to be vented according to manufacturer's instructions.

► Section 15. General Specifications

General Specifications for BH-Series heaters are as follows:

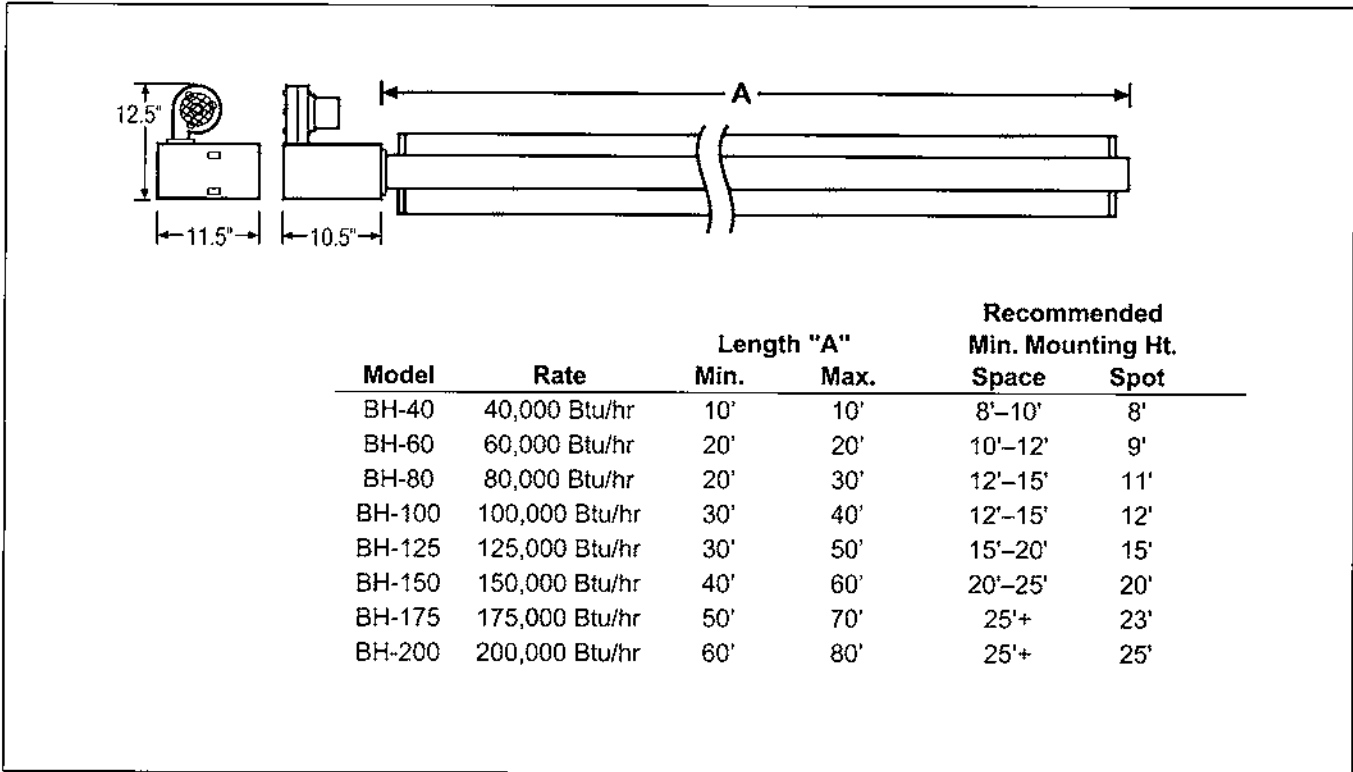

Figure 35. BH-Series Specifications

Gas Pressure at Manifold:

Natural Gas: 3.5" W.C.
LP Gas: 10.5" W.C.
 1/2" NPT (for BH-40, -60, -80, -100, & -125)
 3/4"NPT (for BH-150, -175 & -200)

Gas Inlet Pressure:

Natural Gas: 4.6" W.C. Minimum 14.0" Maximum
 5.0" W.C. Minimum for BH-175, BH-200
LP Gas: 11.0" W.C. Minimum 14.0" Maximum

Electrical Rating: (All Models)

120V- 60 Hz., 1.0 Amp

Dimensions:

Vent Connection Size: 4" (10 cm)
 Outside Air Connection Size: 4" (10 cm)
 Refer to figure above for dimensional information.

► Section 16. BH-Series Limited Warranty

WARRANTY COVERAGE:

Roberts-Gordon, Inc. ("Seller") warrants that entire heating systems sold by it (individually a "System") and any replacement parts which it sells relating to any System ("Parts") shall be free from defects in workmanship and material for the time periods described as follows. With respect to a System this warranty shall apply for a period of three years from delivery to the original purchaser ("Buyer"). With respect to Parts, this warranty shall apply for the longer of the original System warranty period or for a period of one year. ("Systems" and "Parts" are hereinafter collectively referred to as "Products".) This warranty extends only to the original purchaser of Products.

Seller manufactures products which are designed only to provide predetermined ranges of heat rises in various enclosures when properly used in systems designed by purchaser or others and installed by others. Seller makes no representation or warranty with respect to the effect upon enclosure, or upon any of the contents of the enclosure, including, without limitation, all plant or animal life, kept or processed in the enclosure subject to the limitations outlined below.

WARNING:

This warranty is void if the products have been damaged due to accident, abuse, mishandling or any other cause whatsoever other than defects in material or workmanship. Specifically, Seller's warranty shall not apply: (a) to damage to Products when used in an atmosphere containing halogenated hydrocarbons or other corrosive chemicals. Some compounds in the air can be ingested into the equipment and can cause an accelerated rate of corrosion of some of the Products. The use of such chemical compounds in or near the enclosure should be avoided where a longer life of the burner, tubing and other parts is desirable; (b) to Products which have been repaired or replaced with other than factory parts, modified in any way, misused or damaged, or which have been installed or used contrary to Seller's written instructions or manuals; or (c) to any damage resulting from improper service or a lack of proper maintenance.

LIMITATIONS OF WARRANTY:

Other than as stated herein or in any other warranty of Seller, there are no other warranties of any kind whatsoever, express or implied, and all other express and all implied warranties of merchantability and/or fitness for any particular purpose are hereby specifically disclaimed.

EXCLUSIVE REMEDY:

The sole and exclusive remedy for any loss, damage or liability, or otherwise, is limited to the obligation of Seller to repair or replace parts, at its factory, of any product owned by original buyer and returned to the Seller's factory within one year after invoice, with transportation charges prepaid, which examination reveals to have been defective. Under no circumstances shall Seller be liable for any loss, damage, cost, expenses, or incidental or consequential damages of any kind, in connection with the sale, installation, use, maintenance, or repair of any Product.

BUYER RESPONSIBLE FOR DATA:

Seller and its representative may furnish Buyer, upon Buyer's request, data relating to the function and use of Products. Seller shall not be liable for loss, damage, cost, expenses or incidental or consequential damages of any kind, sustained directly or indirectly, by any person, or to any property, if Buyer adopts and uses such data in whole or in part.

LIMITATIONS ON AUTHORITY OF REPRESENTATIVES:

No representative of Seller, other than an Executive Officer, has authority to change or extend these provisions. Changes or extension shall be binding only if confirmed in writing by Seller's duly authorized Executive Officer.

Direct any question or warranty claims to the original installer:

Company: _____

Address: _____

Phone: _____

Or to: Warranty Claims
Roberts-Gordon, Inc.
1250 William Street
P.O. Box 44
Buffalo, NY 14240-0044

Warranty Claims
Roberts-Gordon Canada, Inc.
241 South Service Road West
Grimsby, Ontario L3M 1Y7

