

GORDON-RAY

**VENTED INFRARED
RADIANT TUBE GAS HEATER**

MODEL

RTH-75A

**SPECIFICATIONS
INSTALLATION, OPERATION, SERVICE
& SPARE PARTS**



**Roberts
Gordon, Inc.**

Subsidiary of A.J. Industries Inc.
Buffalo, New York 14240

Quality Gas Heating Equipment for over 50 Years



General Specifications

Model: RTH-75A

Rating: (Natural and L.P. Gas) - 75,000 BTU/HR INPUT

Gas Pressure at Manifold:

Natural Gas 3.5" W.C.
 L.P. Gas 10.0" W.C.
 Gas Connection Size 3/8" IPS

Electrical Rating - 120V, 60 Cy, 2.6 amp.

Flue Connection Size 5" O.D.

Weight of Heater 110 lbs.

Gas	Gas Inlet Pressure	
	Minimum	Maximum
Natural	4.5" W.C.	7.0" W.C.
L.P.	11.0" W.C.	14.0" W.C.

Clearances to Combustibles

	Above	Below	Side	Rear
Standard Reflector	12"	54"	27"	27"
Side Extension Reflector	12"	54"	27"	8"

In all situations, clearances to combustibles must be maintained. (WARNING: Minimum clearance from heater must be maintained from vehicles parked below heater.)

Standard Equipment Includes:

Complete heater assembled, consisting of: Cast-iron burner, coated steel combustion chamber, fully automatic controls, motor with thermal overload switch, balanced air rotor, 4" O.D. radiant tube with stainless steel air preheater and baffles, shut-off cock, aluminum reflector and built-in draft hood.

OPTIONAL: Thermostats, Decorative Aluminum Grille, Reflector Side Extension.

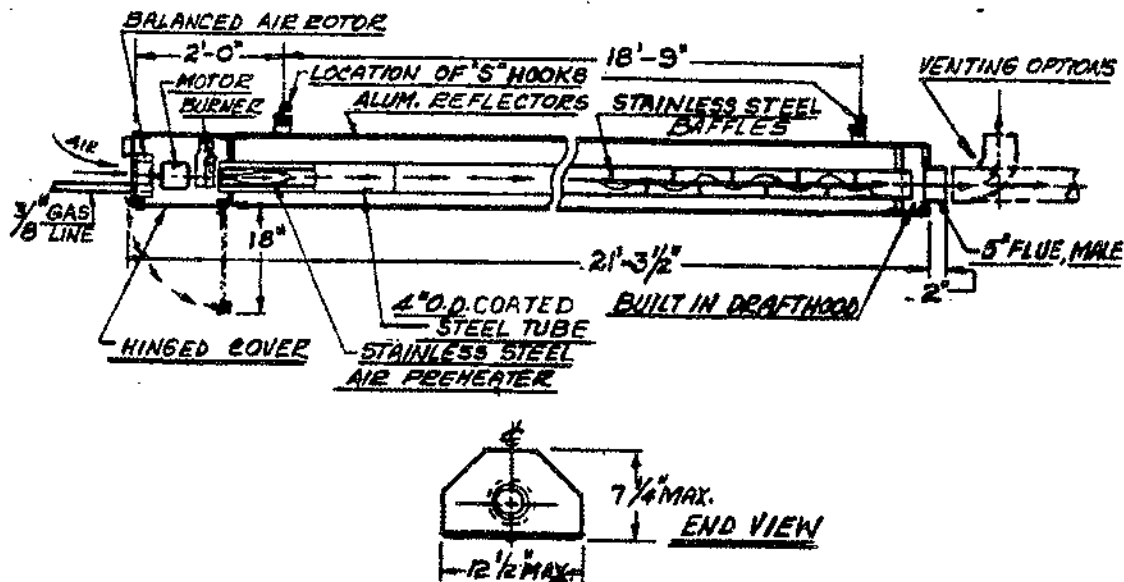

Fig. 1 - Side View Showing Hanger Supports

Installation in Aircraft Hangars

Heaters must be installed in accordance with specification ANS/NFPA 409-1965 and with special consideration for the following:

1. Heaters in aircraft storage or service areas shall be installed at a height of at least 10 feet above the upper surface of wings or engine enclosures of the highest aircraft which may be housed in the hangar. (This should be measured from the bottom of the heater to the wing or engine enclosure whichever is highest from the floor).
2. In other sections of aircraft hangars, such as shops or offices communicating with airplane storage or servicing area, heaters shall be installed in accordance with their listings and not less than eight feet above the floor.
3. Heaters installed in aircraft hangars shall be so located as not to be subject to damage by aircraft, cranes, movable scaffolding or other objects. Heaters shall be placed so they will be readily accessible for maintenance purposes.

Installation in Public Garages

In accordance with the standard for parking instructions, NFPA 88A-1979, or the standard for repair garages, NFPA 88B-1979.

1. Heaters shall be installed in accordance with their listings and not less than eight feet above the floor. Minimum clearances to combustibles must be maintained from vehicles parked below the heater.
2. When installed over hoists, clearance to combustibles must be maintained from top of vehicle on hoist or in elevated position.

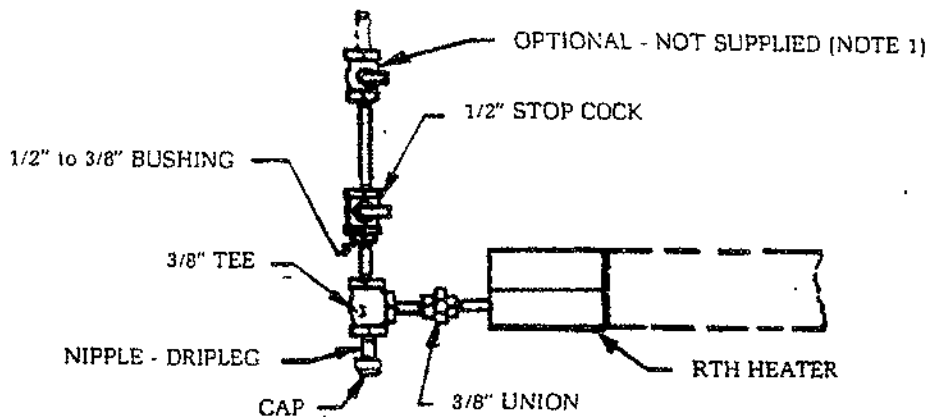

Fig. 3 - Typical Gas Piping Arrangement

NOTE (1) High pressure stop cock as supplied by installer if required.

Electrical

1. Heaters are normally controlled by thermostats (See Fig. 4a & 4b). Line voltage thermostats are wired directly; the recommended 24 volt thermostats use a relay per Figure 5a & 5b. Heaters must be grounded in accordance with National Electrical Code ANSI/NFPA 70-1984. Heaters can also be controlled with a manual line voltage switch or times switch in place of the thermostat.
2. For schematic of factory wiring RTH Heater refer to applicable wiring diagram supplied with these instructions.

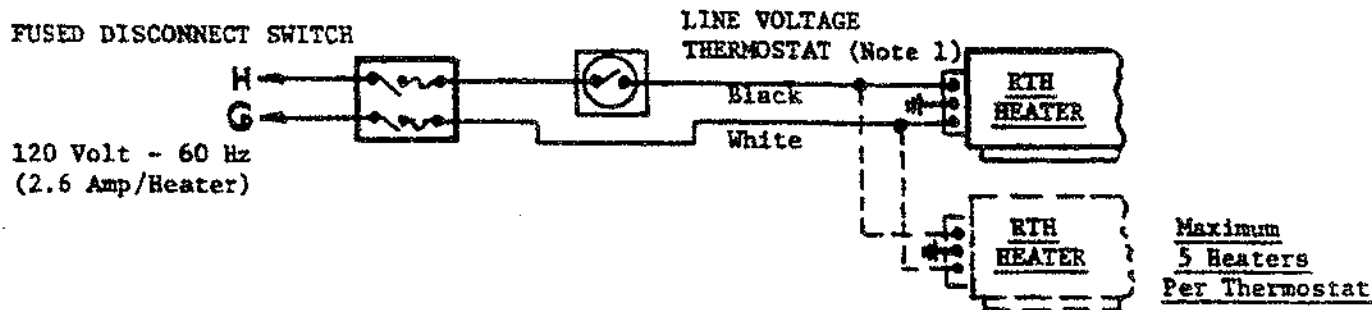

Fig. 4a - "Field" Wiring of Line Voltage Thermostat

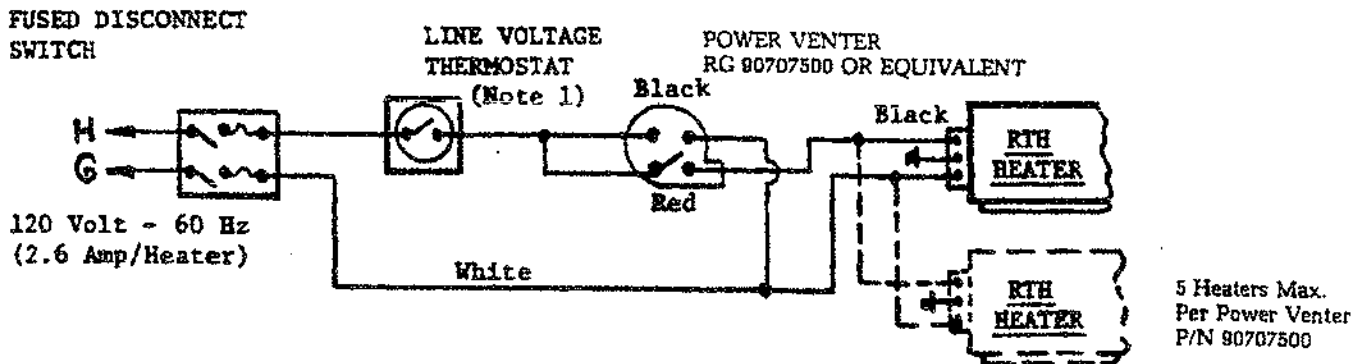

Fig. 4b - "Field" Wiring of Line Voltage Thermostat with Power Venting

Note:

1. For wiring line voltage thermostat White-Rodgers P/N 176-12 (RG 90411300) use terminals "B" and "R" and jumper terminal "W" to "R".

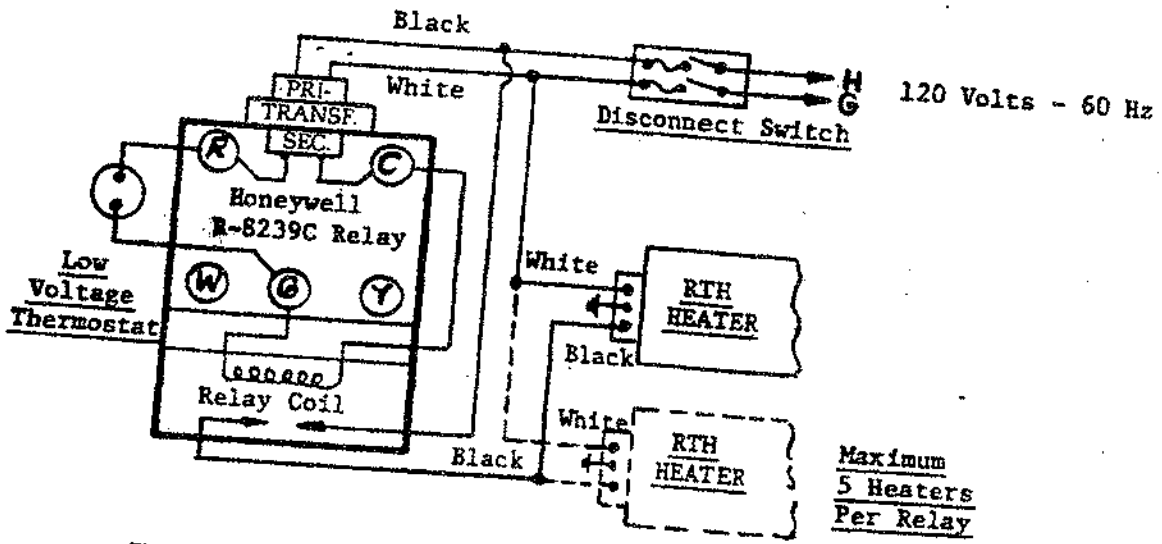

Fig. 5a — "Field" Wiring of Low Voltage Thermostat and Relay

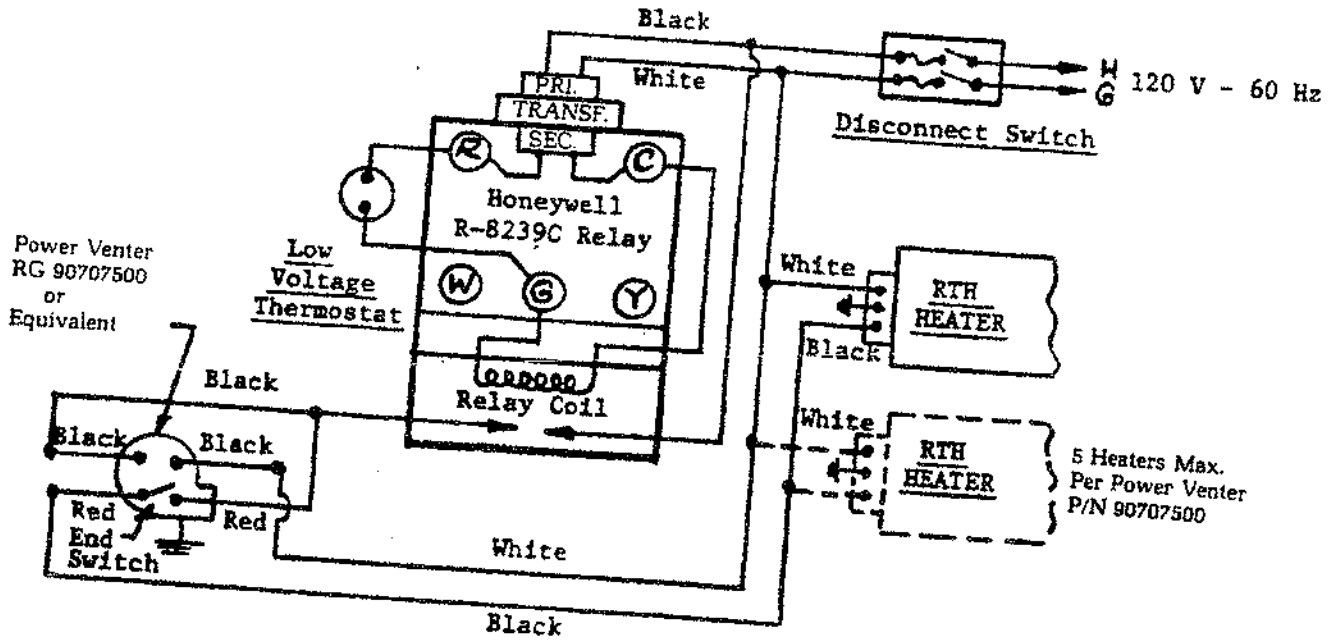

Fig. 5b — "Field" Wiring of Low Voltage Thermostat and Relay and Power Venting

SEQUENCE OF OPERATION

The Gordon-Ray® Heater is equipped with a gas saving spark ignited intermittent pilot. This is how it works:

1. Thermostat, on a call for heat, energizes blower motor of the heater.
2. After the blower motor achieves running speed, the centrifugal motor end switch closes, energizing the pilot valve and the spark generator.
3. Gas flows through the pilot valve, and is ignited by the spark plug, establishing pilot flame.
4. The pilot flame heats the pilot sensing element, and through its contacts, energizes the main gas valve. Gas is ignited by the pilot, establishing main flame.
5. When the thermostat is satisfied, all current to the heater is deenergized and all gas is shut off.

SERVICE INSTRUCTIONS

CAUTION: BEFORE OPENING HINGED CONTROL HOUSING COVER TO SERVICE HEATER, BE SURE THAT GAS AND ELECTRIC SUPPLY TO HEATER ARE TURNED OFF. NEVER START HEATER WITH COVER OPEN.

No power to heater

1. Check to see that thermostat is calling for heat and check thermostat wiring.
2. Check for blown fuse in electrical supply to heater.
3. Check for loose or broken wire at heater junction box.

Blower motor fails to run

1. Check for loose or broken wire from motor to hot and ground leads entering the control housing.
2. Check to see if blower impeller turns freely. It may be rubbing or motor may be seized. Adjust to free impeller, or repair or replace motor.

Caution: Close and secure control housing before operating heater.

No Spark: (When blower motor attains running speed, the motor end switch energizes the spark plug.)

1. With gas to heater turned OFF and control housing cover open, set thermostat above room temperature. The spark across the gap of the plug is normally audible. If no sound is heard:
 - a. Check for loose or broken leads from motor end switch.
 - b. Check spark plug for bridged gap or cracked insulator and gap for .125 in.
 - c. Check spark plug lead and connectors for tightness and continuity.
 - d. Check spark generator for loose or broken wires. Replace spark plug or generator if defective.

Caution: Close and secure control housing before operating heater.

No Gas Present (Shut-off cock open)

1. Set thermostat above room temperature. When blower motor attains running speed, the end switch energizes the pilot valve. At this moment an audible "click" should be heard, if not:
 - a. Check for broken or loose wire lead from motor end switch.
 - b. Check for loose or broken wire to pilot valve. Replace pilot valve coil if defective.

Caution: Close and secure control housing before operating heater.

Cover - Air Seal

1. To secure the cover, screw down the 1/4 in. slotted hex head screw. This provides the air seal and maintains the positive pressure from the blower as required for proper operation of the burner. Covers with warping or bending must be repaired or replaced. Felt gasket strips are also essential for proper operation and heater should not be operated if the gaskets do not seal the complete perimeter of the cover.

Main Burner Does Not Light:

1. After pilot flame is established, it must heat the flame sensing element to energize the main valve. Pilot flame may be observed through side or bottom observation window.
 - a. Pilot flame should be blue and extend at least 1 inch beyond the end of the pilot burner screen. If not, shut off gas and electricity, open cover, remove pilot burner and check orifice for dirt.
 - b. If pilot flame appears suitable, observe color of pilot sensing element, which should glow a dark red or orange color. If the element is not a dark red or orange color, check that the mounting bracket positions, the element in the pilot flame and the proper pilot switch is installed (PN 02510800). With PN 02510800, the extension of the element beyond the mounting bracket will be at least 1-15/16 inch, see Figure 6.
 - c. If element is red or orange, check for broken or loose wires from main gas valve. Replace defective pilot switch.

Caution: Close and secure control housing before operating heater.

Fig. 6 — Burner Detail

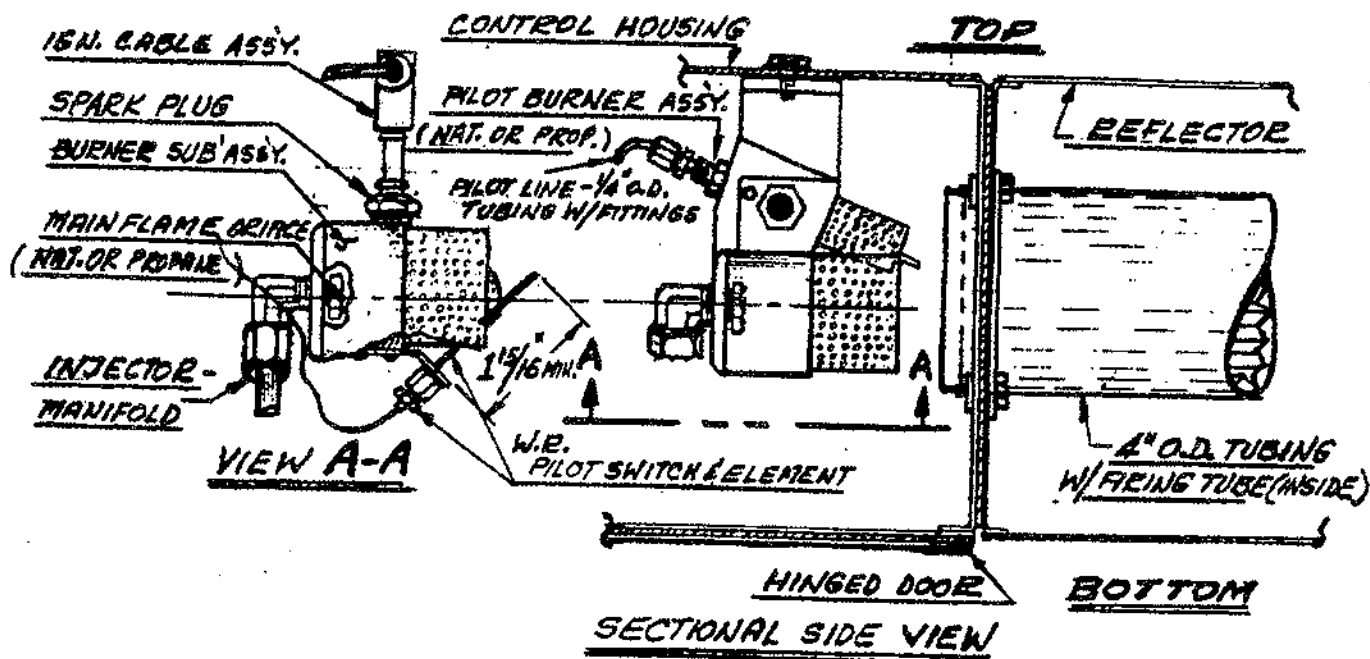

MAINTENANCE

For best performance, heater should be cleaned before each heating season.

1. BE SURE GAS AND ELECTRIC SUPPLY TO HEATER ARE OFF.
2. Open burner control housing cover.
3. Check condition of blower scroll and motor. Dirt and dust may be blown out with compressed air or a vacuum cleaner may be used.
4. Check condition of burner and pilot.
5. Make visual check of spark plug. Replace if there is excessive carbon residue, erosion of electrodes or other defects. Gap should be .125".

Caution: Be sure control housing cover is closed tight before operating heater.

6. Remove elbow or flue pipe from heater. Remove screw holding stainless steel baffle in place in heater tube; then remove baffle. Brush clean if any soot or scale deposits are found on baffle.
7. With baffle removed, check inside of firing tube with flashlight. If carbon or scale are present, scrape out deposits with wire brush on a rod or metal plate attached to wooden pole.
8. Replace flue baffle and baffle retaining screw.
9. Check flue pipe for soot or dirt. After cleaning, reattach flue pipe to heater.
10. Outside surfaces of heater reflector may be cleaned by wiping with a damp cloth.

SPECIAL INSTRUCTIONS FOR INSTALLATION OF SIDE EXTENSION REFLECTORS FOR RTH-75 HEATER

One complete set of Side Extension Reflector materials is as follows:

Four 5 ft. long side extension reflector 02551600

Five side extension support brackets 02551700

See Figure 7

With the RTH-75 heater located, suspended and starting at one end of the heater with one section of the side extension reflector, position the snap lock edge of this reflector against the bottom edge of the standard reflector 02550000. See detail "A" of Figure 7. Tilt the side extension reflector inward and engage the metal edge of 02550000 reflector and the "V" groove of 02551600. Tilt 02551600 downward and snap it onto reflector 02550000. Install one side extension reflector support bracket 02551700 on the end of the heater by removing one of the #10 screws which secure reflector support 02520400, insert the screw through 02520400, reassemble the screw into heater and secure in place. Engage the bottom edge of the side extension reflector 02551600 into the bottom part of 02521700.

Install the next section of perimeter reflector overlapping the first section, and proceed as above until all four sections and all five support brackets are secured in place.

Special Instructions for Installing Decorative Grille

Remove the bulkheads on the end of the heater. (See Figure 7). Slide the decorative grille into the heater as shown in Figure 7, Detail A. Replace the bulkheads.

Fig. 7 — Installation of Side Extension Reflectors with RTH-75 Heater

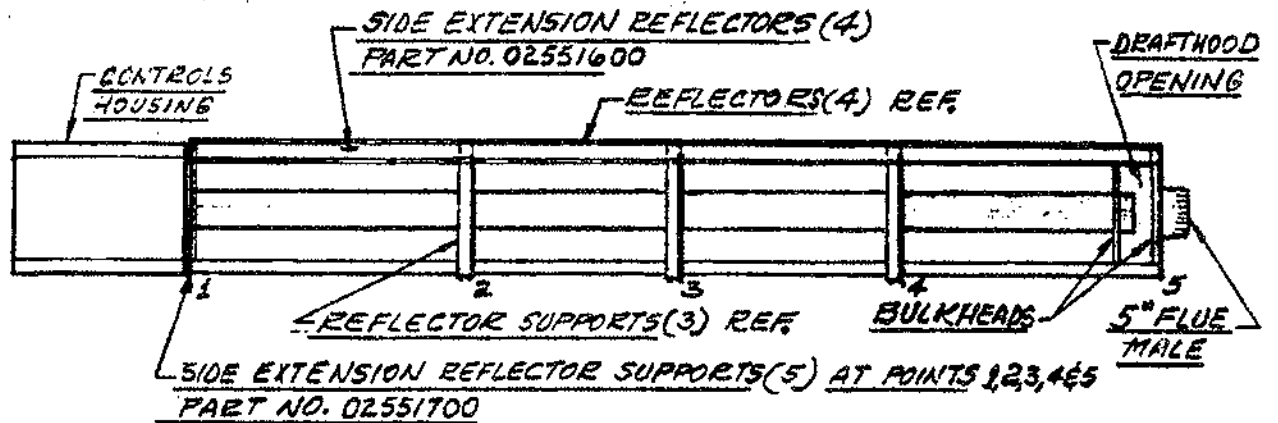

RTH-75 Heater - Bottom View Above
End View Below

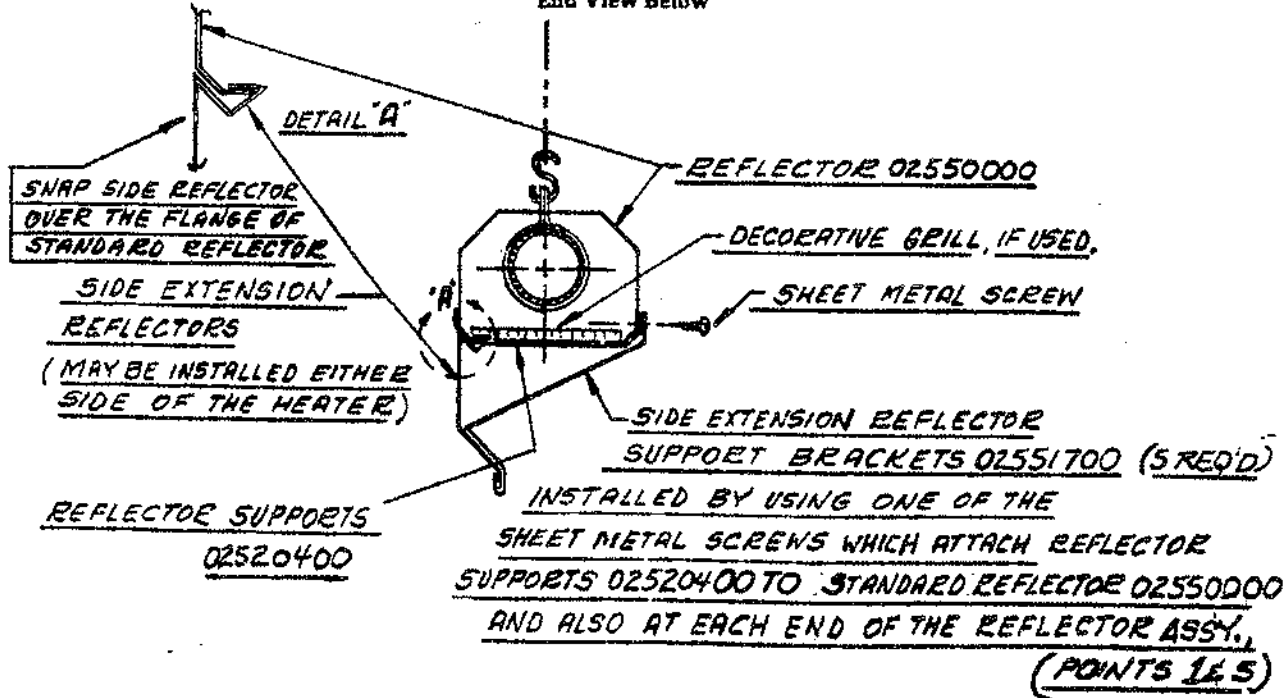

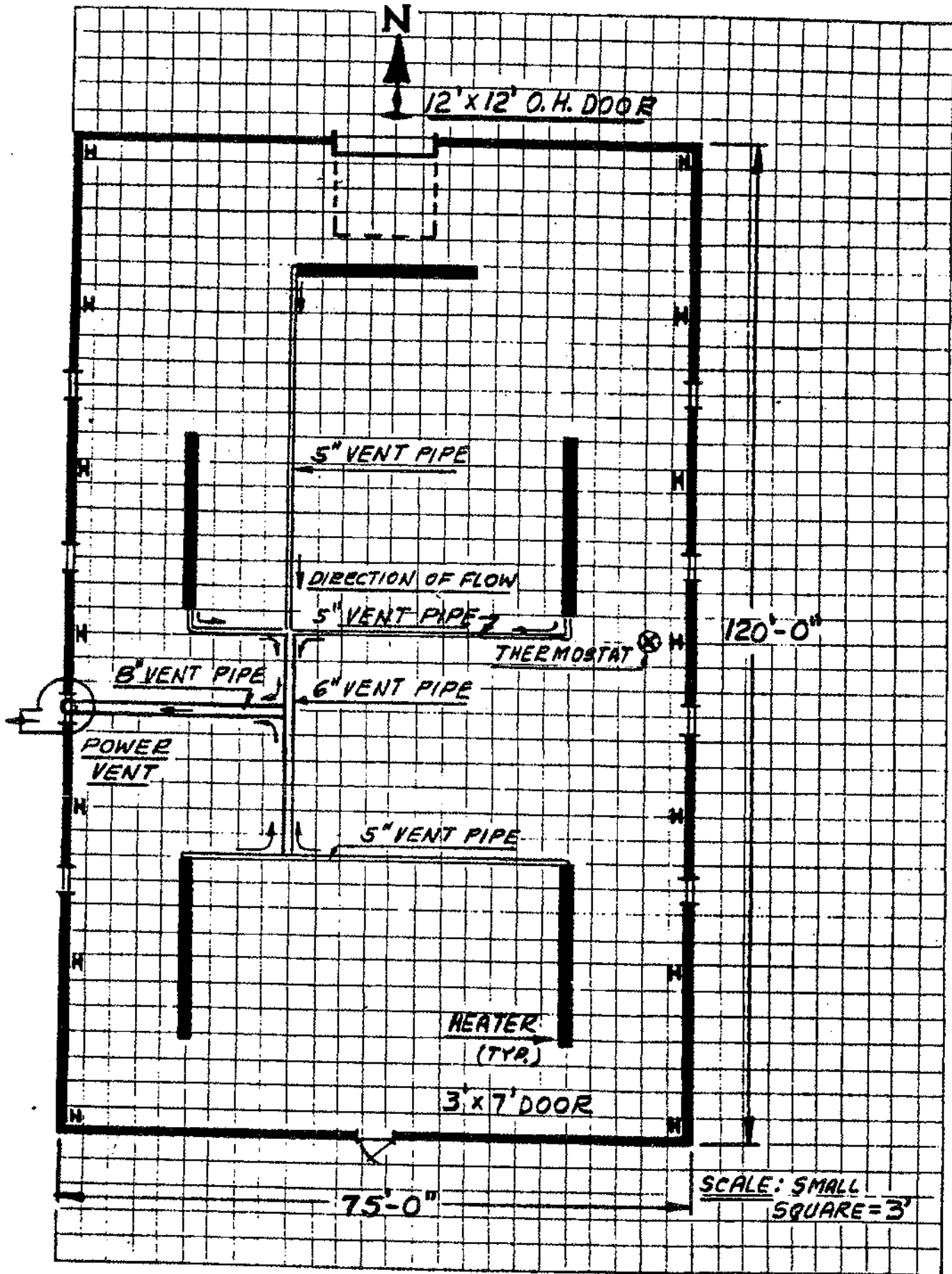

Fig. 8 — Venting Example Using Power Vent

RTH-75A HEATER
Burner & Controls Assembly

ITEM	DESCRIPTION	PART NO.	QTY.
1	W. R. Pilot Switch Assembly	02510800	1
2	Orifice, Main Flame (Nat. Gas)	91910423	} Use 1
3	Orifice, Main Flame (Propane Gas)	91910442	
4	Burner Housing Assembly (Complete)	02512000	1
5	Injector Manifold, Main Flame	02511200	1
6	Aluminum Tubing 1/4" O.D. Pilot Line	02590500	1
7	Gas Valve, Nat. Gas (NC-1-1181-1F)	70100500	1
8*	Gas Valve, Propane (7010AGVERLP)	90026900	1
9*	Gas Valve, Propane (FJ. 3/8)	90025800	1
10	Cover Assembly	02512100	1
11	Motor (Ball Bearing Type)	90603800	1
12	Motor Mount Plate Assembly	02520101	1
13	Manifold Nipple Assembly (Natural Gas)	02521701	} Use 1
14*	Manifold Nipple Assembly (Propane Gas)	02521703	
15	Screw Hex Head, 1/4-20	93413008	13
16	Ring, Viewer	01390200	3
17	Gasket, Observ. Window	01351200	3
18	Mica Window	02553200	3
19	Airrotor	90707800	1
20	Air Inlet Plate Assembly	02521400	1
21	Screw, Sheet Mtl., Hex Head #10, Type "A"	94311008	8
22	Weid Nut, 1/4-20	91100703	1
23	Screw, Socket Head, 1/4-20	93713022	1
24	Junction Box	91309300	1
25	Cover, Junction Box	91310900	1
26	SR6P3-4 Heycos	91309600	1
27	Wire Harness	01327900	1
28	Screw, Hex Hd. Slotted, 1/4-20	93313010	1
29	Wire Nuts	91312900	3
31	Spark Igniter (Replacement Kit)	01316600	1
32	"Keys" Nut No. 8-32	92311400	4
33	Wire Harness With Socket	02521100	1
34	Plate, Pilot Switch & Igniter Mtg.	02554100	1
35	Aluminum Sleeve	01356300	4
36	Ignition Cable Assembly	02521500	1
37	Pilot Burner Assembly (Natural Gas) No. 68	02511000	} Use 1
38	Pilot Burner Assembly (Propane) No. 77	02511001	
39	Ext. Tooth Lock Washer, 1/4"	96211500	2
40	Burner Sub. Assembly	02522700	1
41	Spark Plug, Auburn E4RB	91313100	1
42	Screw, Retainer	91116600	1
43	Ball Sleeve 1/4" O.D. Tubing	00878300	2
44	Ball Sleeve Nut 1/4" O.D. Tubing	00878400	2
45	Name Plate	91005300	1
46	"Caution" Sign	91005600	1
47	Connection Diagram	D-965	1
48	Gasket, Door Sides	02554500	2
49	Gasket, Door Ends	02554501	2
50	Rivet	91104300	4
51*	Nipple 3/8 N.P.T. x 2" Lg.	91201602	1

*NOTE: See "View Valve Train — Propane Gas" Fig. 9
Form No. F-1394 (Rev 3-86)

BURNER AND CONTROL ASSY. -
 NATURAL OR PROPANE GAS
 MODEL RTH-75A HEATER

Figure 9

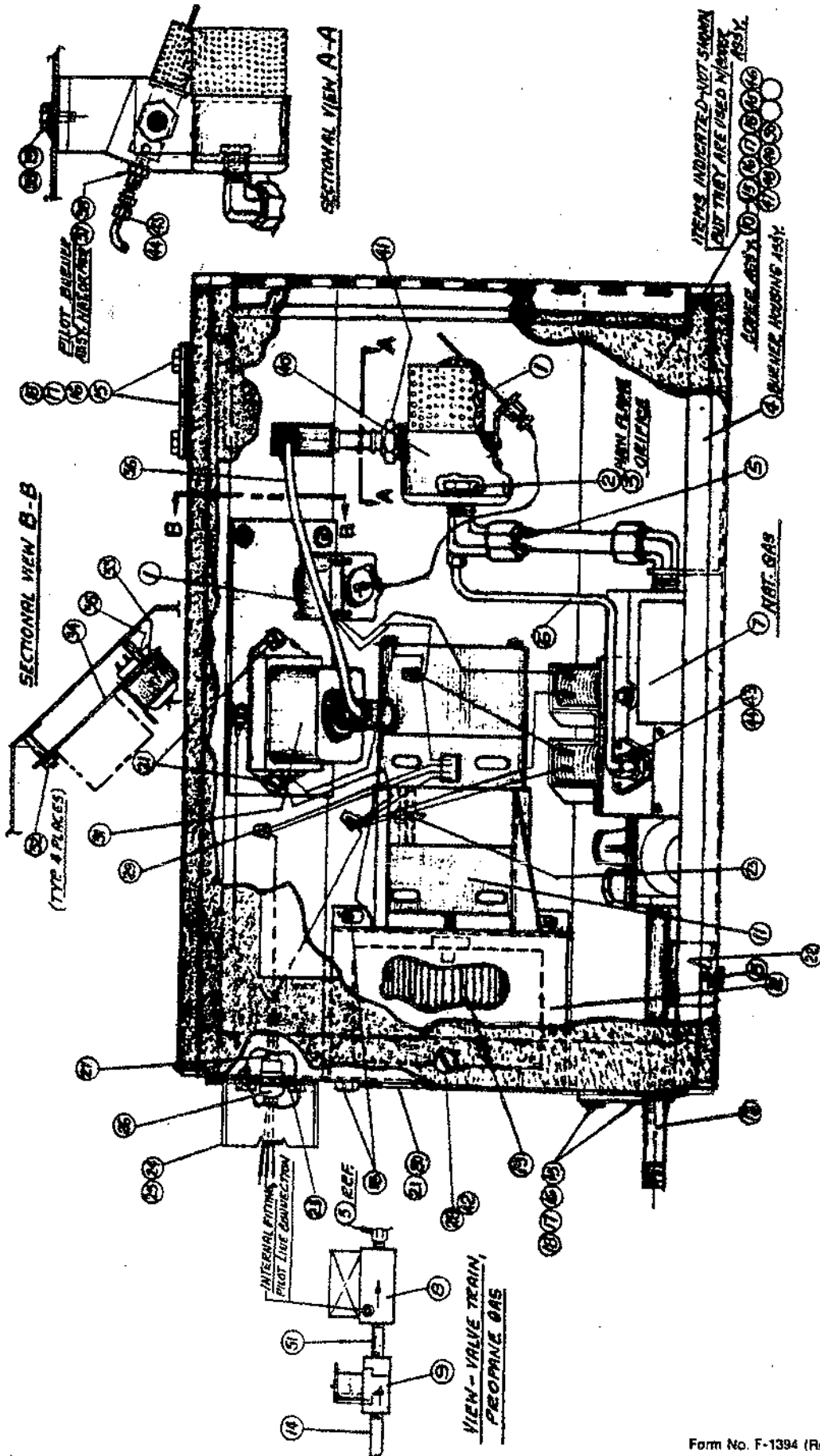

GORDON-RAY

**VENTED INFRARED
RADIANT TUBE GAS HEATER**

MODEL

RTH-75A

**SPECIFICATIONS
INSTALLATION, OPERATION, SERVICE
& SPARE PARTS**



**Roberts
Gordon, Inc.**

Subsidiary of A.J. Industries Inc.
Buffalo, New York 14240

Quality Gas Heating Equipment for over 50 Years



General Specifications

Model: RTH-75A
 Rating: (Natural and L.P. Gas) - 75,000 BTU/HR INPUT
 Gas Pressure at Manifold:

Natural Gas 3.5" W.C.
 L.P. Gas 10.0" W.C.
 Gas Connection Size 3/8" IPS

Electrical Rating - 120V, 60 Cy, 2.6 amp.
 Flue Connection Size 5" O.D.
 Weight of Heater 110 lbs.

Gas Inlet Pressure
 Gas Minimum Maximum
 Natural 4.5" W.C. 7.0" W.C.
 L.P. 11.0" W.C. 14.0" W.C.

Clearances to Combustibles

	Above	Below	Side	Rear
Standard Reflector	12"	54"	27"	27"
Side Extension Reflector	12"	54"	27"	8"

In all situations, clearances to combustibles must be maintained. (WARNING: Minimum clearance from heater must be maintained from vehicles parked below heater.)

Standard Equipment Includes:

Complete heater assembled, consisting of: Cast-iron burner, coated steel combustion chamber, fully automatic controls, motor with thermal overload switch, balanced air rotor, 4" O.D. radiant tube with stainless steel air preheater and baffles, shut-off cock, aluminum reflector and built-in draft hood.

OPTIONAL: Thermostats, Decorative Aluminum Grille, Reflector Side Extension.

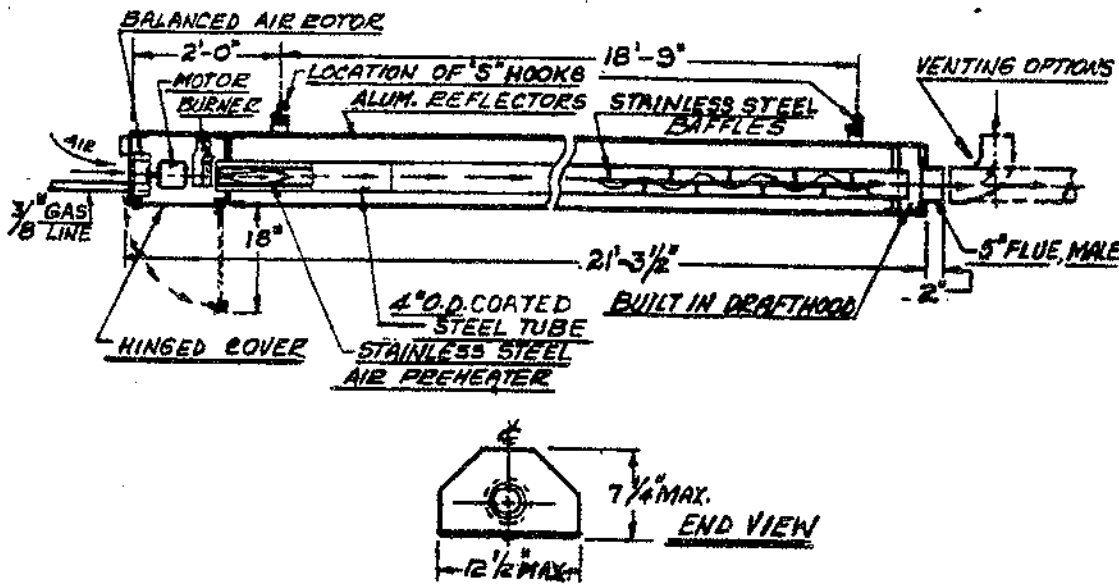

Fig. 1 - Side View Showing Hanger Supports

Installation in Aircraft Hangars

Heaters must be installed in accordance with specification ANS/NFPA 409-1965 and with special consideration for the following:

1. Heaters in aircraft storage or service areas shall be installed at a height of at least 10 feet above the upper surface of wings or engine enclosures of the highest aircraft which may be housed in the hangar. (This should be measured from the bottom of the heater to the wing or engine enclosure whichever is highest from the floor).
2. In other sections of aircraft hangars, such as shops or offices communicating with airplane storage or servicing area, heaters shall be installed in accordance with their listings and not less than eight feet above the floor.
3. Heaters installed in aircraft hangars shall be so located as not to be subject to damage by aircraft, cranes, movable scaffolding or other objects. Heaters shall be placed so they will be readily accessible for maintenance purposes.

Installation in Public Garages

In accordance with the standard for parking instructions, NFPA 88A-1979, or the standard for repair garages, NFPA 88B-1979.

1. Heaters shall be installed in accordance with their listings and not less than eight feet above the floor. Minimum clearances to combustibles must be maintained from vehicles parked below the heater.
2. When installed over hoists, clearance to combustibles must be maintained from top of vehicle on hoist or in elevated position.

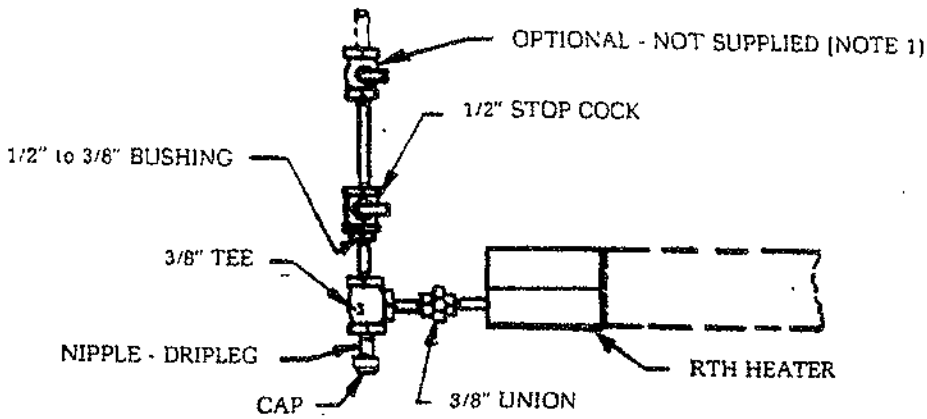

Fig. 3 -- Typical Gas Piping Arrangement

NOTE (1) High pressure stop cock as supplied by installer if required.

Electrical

1. Heaters are normally controlled by thermostats (See Fig. 4a & 4b). Line voltage thermostats are wired directly; the recommended 24 volt thermostats use a relay per Figure 5a & 5b. Heaters must be grounded in accordance with National Electrical Code ANSI/NFPA 70-1984. Heaters can also be controlled with a manual line voltage switch or times switch in place of the thermostat.
2. For schematic of factory wiring RTH Heater refer to applicable wiring diagram supplied with these instructions.

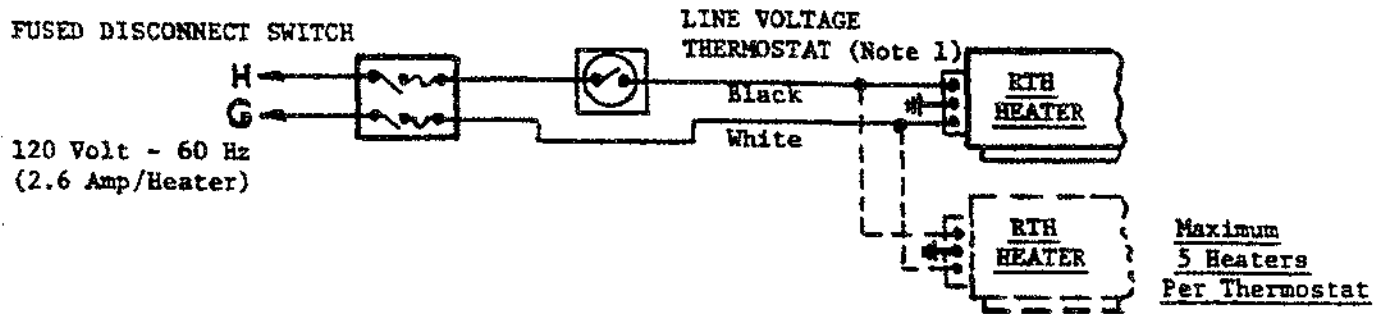

Fig. 4a -- "Field" Wiring of Line Voltage Thermostat

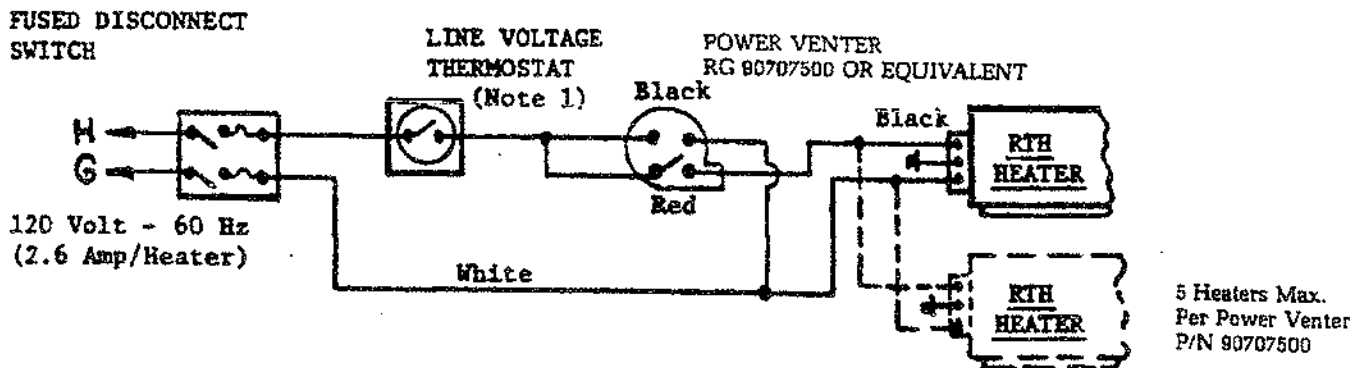

Fig. 4b -- "Field" Wiring of Line Voltage Thermostat with Power Venting

- Note:
1. For wiring line voltage thermostat White-Rodgers P/N 176-12 (RG 90411300) use terminals "B" and "R" and jumper terminal "W" to "R".

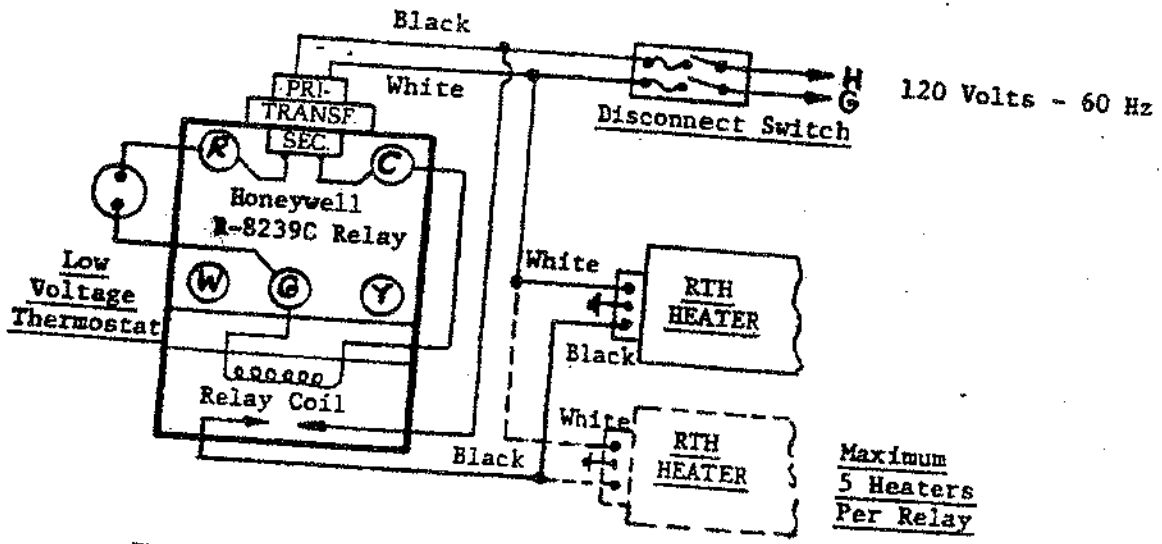

Fig. 5a — "Field" Wiring of Low Voltage Thermostat and Relay

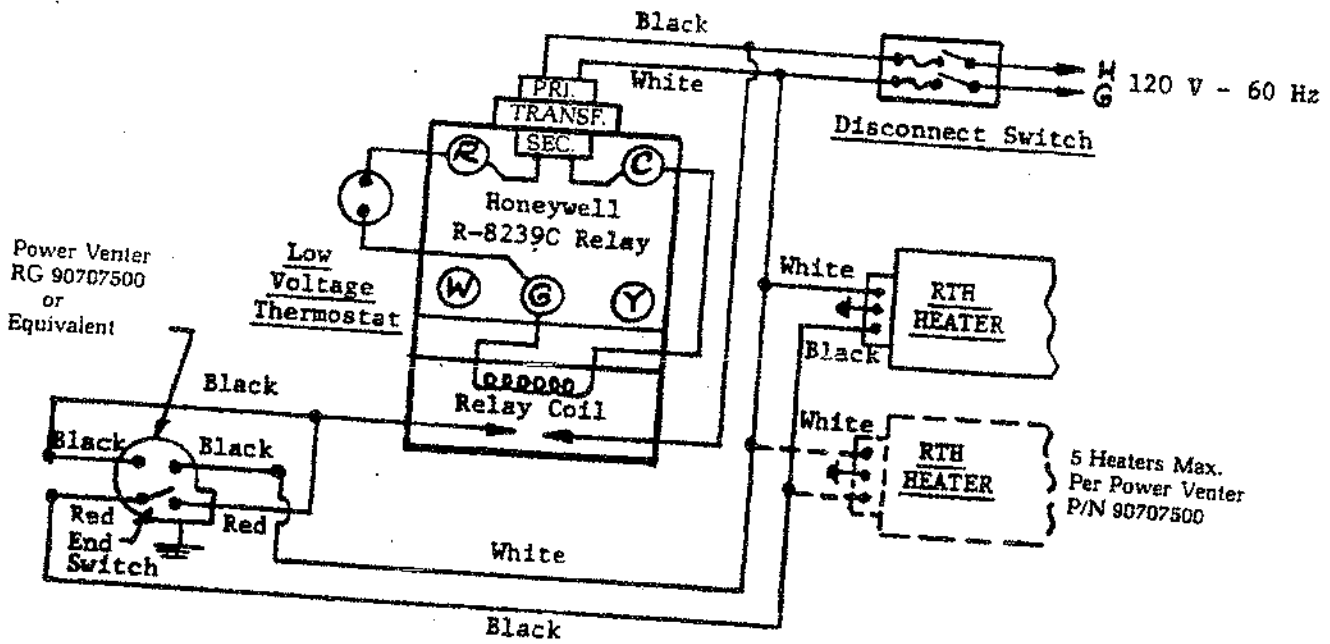

Fig. 5b — "Field" Wiring of Low Voltage Thermostat and Relay and Power Venting

SEQUENCE OF OPERATION

The Gordon-Ray® Heater is equipped with a gas saving spark ignited intermittent pilot. This is how it works:

1. Thermostat, on a call for heat, energizes blower motor of the heater.
2. After the blower motor achieves running speed, the centrifugal motor end switch closes, energizing the pilot valve and the spark generator.
3. Gas flows through the pilot valve, and is ignited by the spark plug, establishing pilot flame.
4. The pilot flame heats the pilot sensing element, and through its contacts, energizes the main gas valve. Gas is ignited by the pilot, establishing main flame.
5. When the thermostat is satisfied, all current to the heater is deenergized and all gas is shut off.

SERVICE INSTRUCTIONS

CAUTION: BEFORE OPENING HINGED CONTROL HOUSING COVER TO SERVICE HEATER, BE SURE THAT GAS AND ELECTRIC SUPPLY TO HEATER ARE TURNED OFF. NEVER START HEATER WITH COVER OPEN.

No power to heater

1. Check to see that thermostat is calling for heat and check thermostat wiring.
2. Check for blown fuse in electrical supply to heater.
3. Check for loose or broken wire at heater junction box.

Blower motor fails to run

1. Check for loose or broken wire from motor to hot and ground leads entering the control housing.
2. Check to see if blower impeller turns freely, it may be rubbing or motor may be seized. Adjust to free impeller, or repair or replace motor.

Caution: Close and secure control housing before operating heater.

No Spark: (When blower motor attains running speed, the motor end switch energizes the spark plug.)

1. With gas to heater turned OFF and control housing cover open, set thermostat above room temperature. The spark across the gap of the plug is normally audible. If no sound is heard:
 - a. Check for loose or broken leads from motor end switch.
 - b. Check spark plug for bridged gap or cracked insulator and gap for .125 in.
 - c. Check spark plug lead and connectors for tightness and continuity.
 - d. Check spark generator for loose or broken wires. Replace spark plug or generator if defective.

Caution: Close and secure control housing before operating heater.

No Gas Present (Shut-off cock open)

1. Set thermostat above room temperature. When blower motor attains running speed, the end switch energizes the pilot valve. At this moment an audible "click" should be heard, if not:
 - a. Check for broken or loose wire lead from motor end switch.
 - b. Check for loose or broken wire to pilot valve. Replace pilot valve coil if defective.

Caution: Close and secure control housing before operating heater.

Cover - Air Seal

1. To secure the cover, screw down the 1/4 in. slotted hex head screw. This provides the air seal and maintains the positive pressure from the blower as required for proper operation of the burner. Covers with warping or bending must be repaired or replaced. Felt gasket strips are also essential for proper operation and heater should not be operated if the gaskets do not seal the complete perimeter of the cover.

Main Burner Does Not Light:

1. After pilot flame is established, it must heat the flame sensing element to energize the main valve. Pilot flame may be observed through side or bottom observation window.
 - a. Pilot flame should be blue and extend at least 1 inch beyond the end of the pilot burner screen. If not, shut off gas and electricity, open cover, remove pilot burner and check orifice for dirt.
 - b. If pilot flame appears suitable, observe color of pilot sensing element, which should glow a dark red or orange color. If the element is not a dark red or orange color, check that the mounting bracket positions, the element in the pilot flame and the proper pilot switch is installed (PN 02510800). With PN 02510800, the extension of the element beyond the mounting bracket will be at least 1-15/16 inch, see Figure 6.
 - c. If element is red or orange, check for broken or loose wires from main gas valve. Replace defective pilot switch.

Caution: Close and secure control housing before operating heater.

Fig. 6 -- Burner Detail

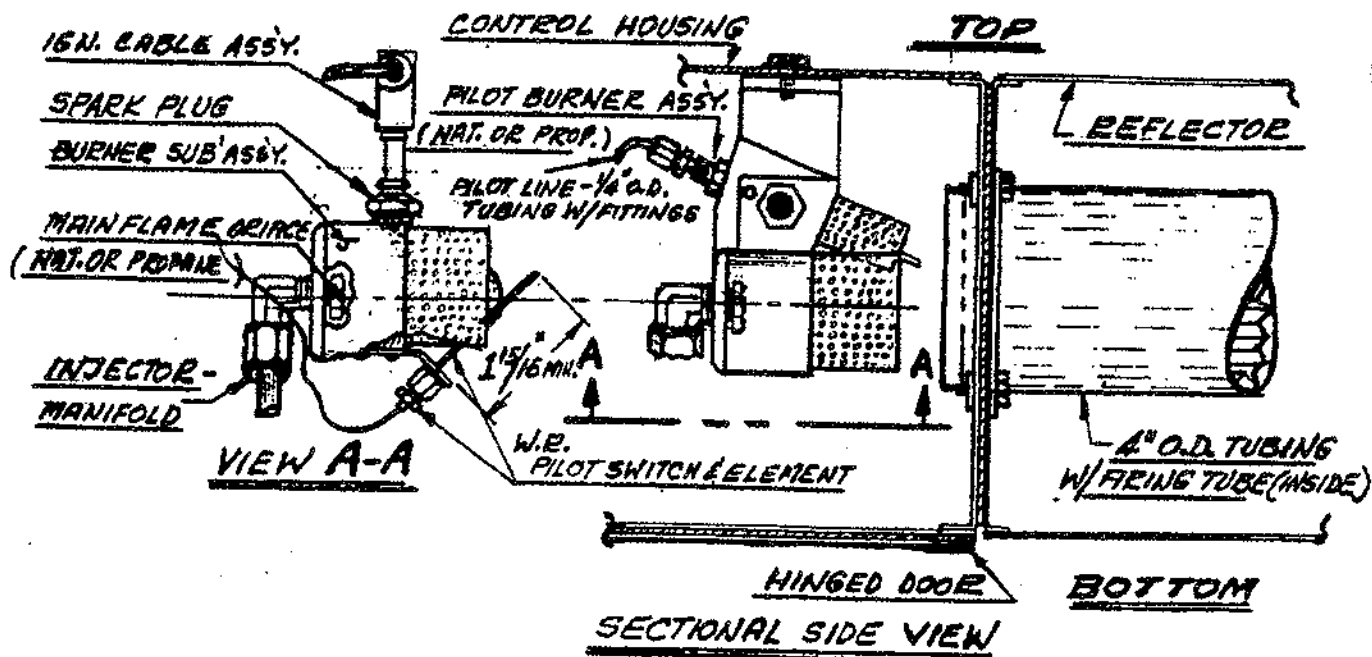

MAINTENANCE

For best performance, heater should be cleaned before each heating season.

1. BE SURE GAS AND ELECTRIC SUPPLY TO HEATER ARE OFF.
2. Open burner control housing cover.
3. Check condition of blower scroll and motor. Dirt and dust may be blown out with compressed air or a vacuum cleaner may be used.
4. Check condition of burner and pilot.
5. Make visual check of spark plug. Replace if there is excessive carbon residue, erosion of electrodes or other defects. Gap should be .125".

Caution: Be sure control housing cover is closed tight before operating heater.

6. Remove elbow or flue pipe from heater. Remove screw holding stainless steel baffle in place in heater tube; then remove baffle. Brush clean if any soot or scale deposits are found on baffle.
7. With baffle removed, check inside of firing tube with flashlight. If carbon or scale are present, scrape out deposits with wire brush on a rod or metal plate attached to wooden pole.
8. Replace flue baffle and baffle retaining screw.
9. Check flue pipe for soot or dirt. After cleaning, reattach flue pipe to heater.
10. Outside surfaces of heater reflector may be cleaned by wiping with a damp cloth.

SPECIAL INSTRUCTIONS FOR INSTALLATION OF SIDE EXTENSION REFLECTORS FOR RTH-75 HEATER

One complete set of Side Extension Reflector materials is as follows:

Four 5 ft. long side extension reflector 02551600

Five side extension support brackets 02551700

See Figure 7

With the RTH-75 heater located, suspended and starting at one end of the heater with one section of the side extension reflector, position the snap lock edge of this reflector against the bottom edge of the standard reflector 02550000. See detail "A" of Figure 7. Tilt the side extension reflector inward and engage the metal edge of 02550000 reflector and the "V" groove of 02551600. Tilt 02551600 downward and snap it onto reflector 02550000. Install one side extension reflector support bracket 02551700 on the end of the heater by removing one of the #10 screws which secure reflector support 02520400, insert the screw through 02520400, reassemble the screw into heater and secure in place. Engage the bottom edge of the side extension reflector 02551600 into the bottom part of 02521700.

Install the next section of perimeter reflector overlapping the first section, and proceed as above until all four sections and all five support brackets are secured in place.

Special Instructions for Installing Decorative Grille

Remove the bulkheads on the end of the heater. (See Figure 7). Slide the decorative grille into the heater as shown in Figure 7, Detail A. Replace the bulkheads.

Fig. 7 — Installation of Side Extension Reflectors with RTH-75 Heater

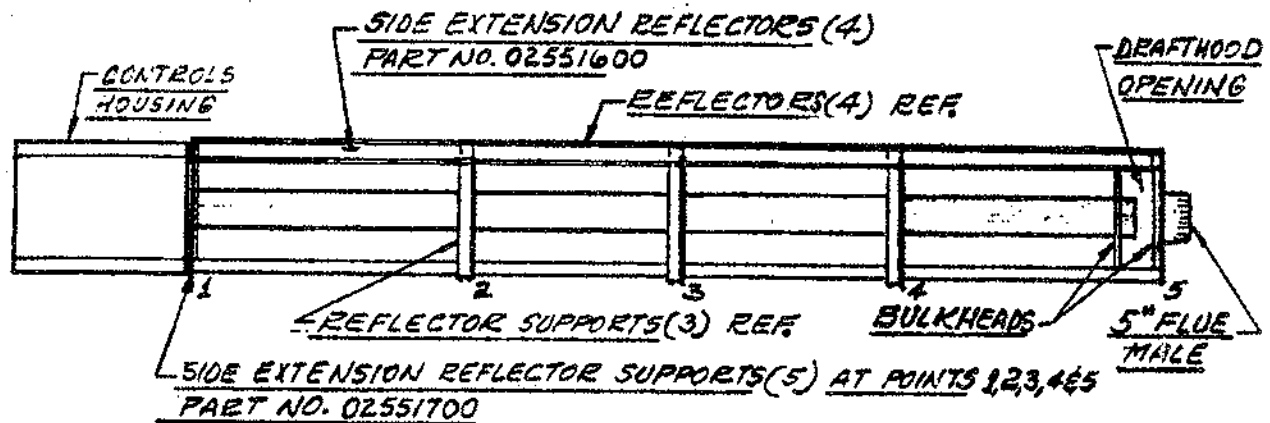

RTH-75 Heater - Bottom View Above
End View Below

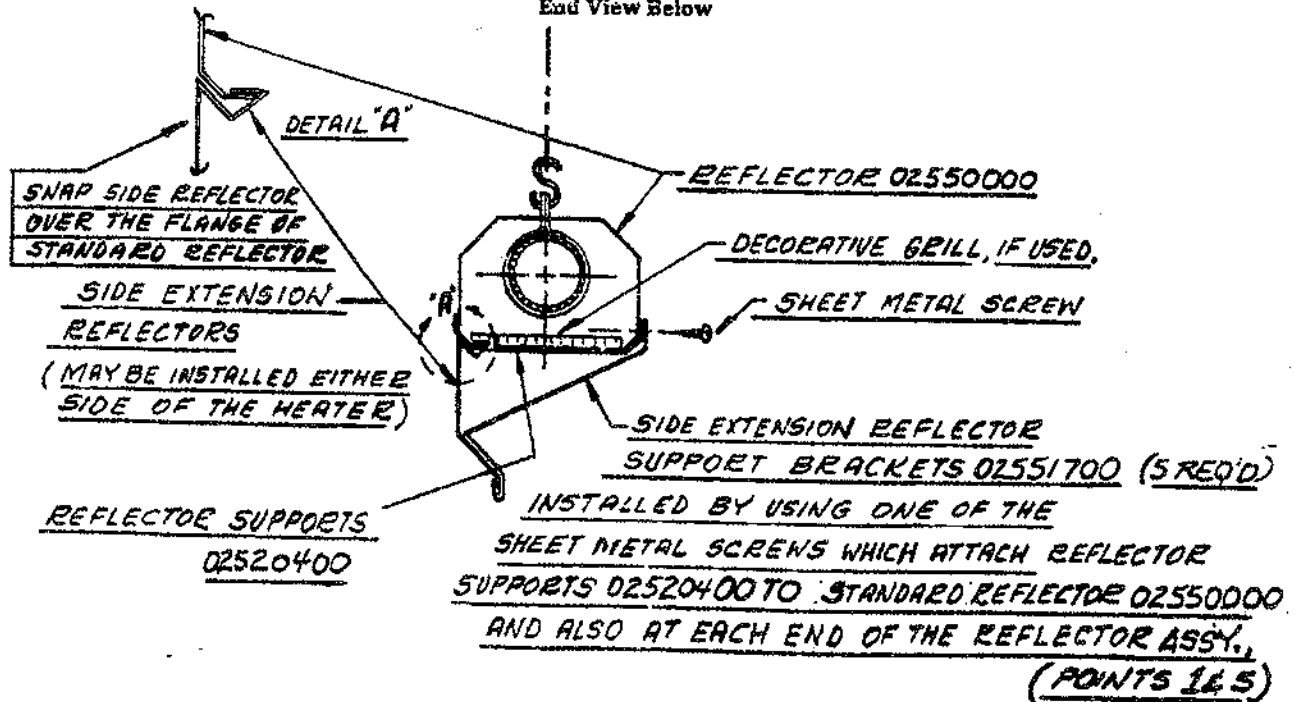

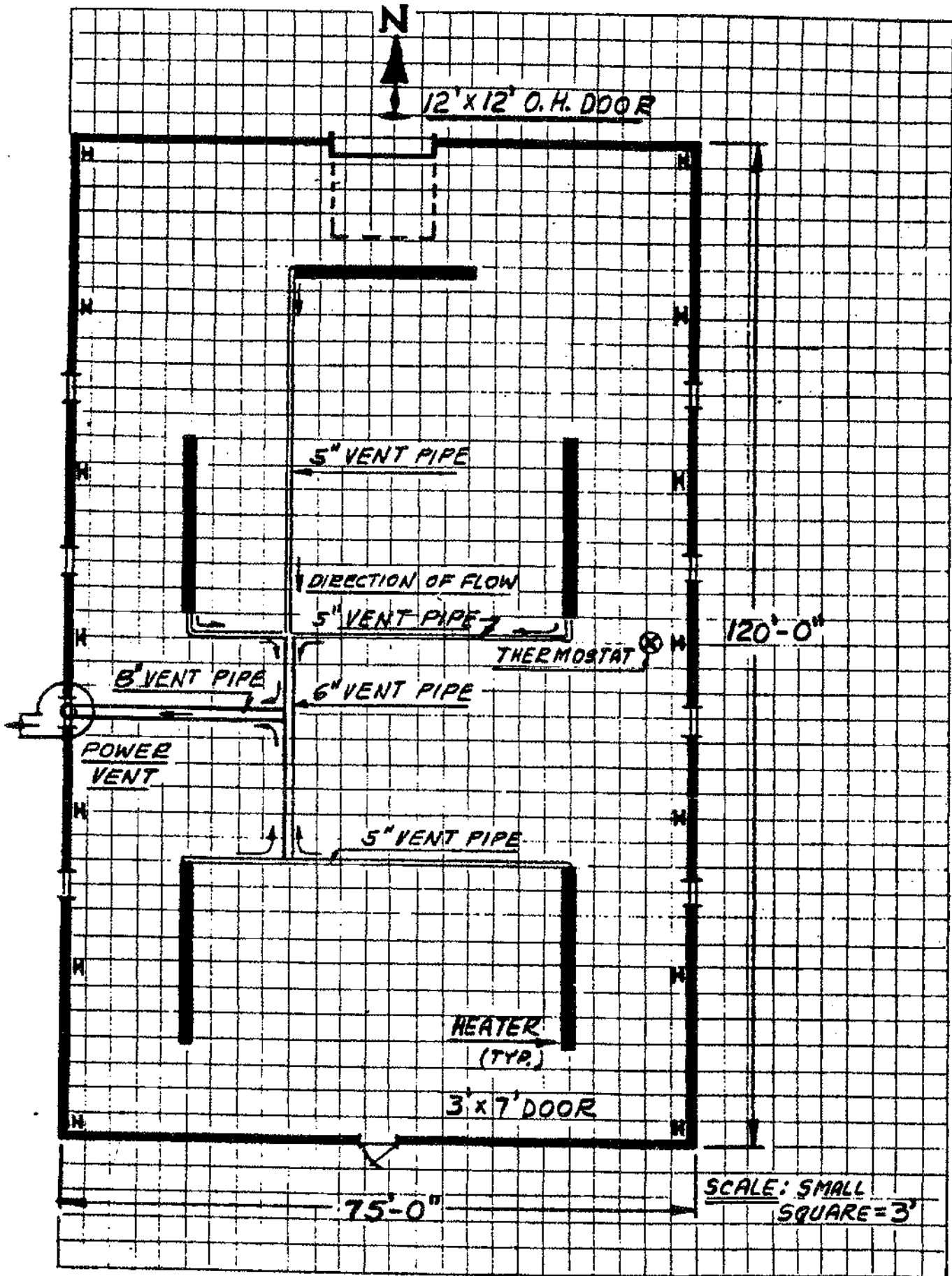

RTH-75A HEATER
Burner & Controls Assembly

ITEM	DESCRIPTION	PART NO.	QTY.
1	W. R. Pilot Switch Assembly	02510800	1
2	Orifice, Main Flame (Nat. Gas)	91910423	} Use
3	Orifice, Main Flame (Propane Gas)	91910442	
4	Burner Housing Assembly (Complete)	02512000	1
5	Injector Manifold, Main Flame	02511200	1
6	Aluminum Tubing 1/4 O.D. Pilot Line	02590500	1
7	Gas Valve, Nat. Gas (NC-1-1181-1F)	70100500	1
8*	Gas Valve, Propane (7010AGVERLP)	90026900	1
9*	Gas Valve, Propane (F.J. 3/8)	90025800	1
10	Cover Assembly	02512100	1
11	Motor (Ball Bearing Type)	90603800	1
12	Motor Mount Plate Assembly	02520101	1
13	Manifold Nipple Assembly (Natural Gas)	02521701	} Use
14*	Manifold Nipple Assembly (Propane Gas)	02521703	
15	Screw Hex Head, 1/4-20	93413008	13
16	Ring, Viewer	01390200	3
17	Gasket, Observ. Window	01351200	3
18	Mica Window	02553200	3
19	Airrotor	90707800	1
20	Air Inlet Plate Assembly	02521400	1
21	Screw, Sheet Mtl., Hex Head #10, Type "A"	94311008	8
22	Weld Nut, 1/4-20	91100703	1
23	Screw, Socket Head, 1/4-20	93713022	1
24	Junction Box	91309300	1
25	Cover, Junction Box	91310900	1
26	SR6P3-4 Heycos	91309600	1
27	Wire Harness	01327900	1
28	Screw, Hex Hd. Slotted, 1/4-20	93313010	1
29	Wire Nuts	91312900	3
31	Spark Igniter (Replacement Kit)	01316600	1
32	"Keps" Nut No. 8-32	92311400	4
33	Wire Harness With Socket	02521100	1
34	Plate, Pilot Switch & Igniter Mtg.	02554100	1
35	Aluminum Sleeve	01356300	4
36	Ignition Cable Assembly	02521500	1
37	Pilot Burner Assembly (Natural Gas) No. 68	02511000	} Use
38	Pilot Burner Assembly (Propane) No. 77	02511001	
39	Ext. Tooth Lock Washer, 1/4"	96211500	2
40	Burner Sub. Assembly	02522700	1
41	Spark Plug, Auburn E4RB	91313100	1
42	Screw, Retainer	91116600	1
43	Ball Sleeve 1/4" O.D. Tubing	00878300	2
44	Ball Sleeve Nut 1/4" O.D. Tubing	00878400	2
45	Name Plate	91005300	1
46	"Caution" Sign	91005600	1
47	Connection Diagram	D-965	1
48	Gasket, Door Sides	02554500	2
49	Gasket, Door Ends	02554501	2
50	Rivet	91104300	4
51*	Nipple 3/8 N.P.T. x 2" Lg.	91201602	1

*NOTE: See "View Valve Train — Propane Gas" Fig. 9
Form No. F-1396 (Rev 3-86)

BURNER AND CONTROL ASS'Y. -
 NATURAL OR PROPANE GAS
 MODEL RTH-75A HEATER

Figure 9

