

VANTAGE II[®]

Low-Intensity Infrared Unitary Heating Systems

CTH2 Series Installation, Operation and Service Instructions

INSTALLER

Please take the time to read and understand these instructions prior to any installation

OWNER

Keep this manual in a safe place to provide your serviceman with information if the situation arises.

⚠ WARNING ⚠

Improper installation, adjustment, alteration, service or maintenance can cause property damage, injury or death. Read the installation, operating and maintenance instructions thoroughly before installing or servicing this equipment.



Roberts  Gordon, Inc.

	SECTION	PAGE
WARNINGS <i>Read this section carefully. Improper installation, adjustment, operation or maintenance can cause property damage, injury or death.</i>	1	pg 01
INTRODUCTION <i>Checking Shipment • Installer Responsibility</i>	2	pg 03
INSTALLATION: Planning <i>National Codes • Critical Considerations • Installation Procedure • Clearances to Combustibles • Standard Parts List</i>	3	pg 04
INSTALLATION: Assembly <i>Assembly Overview • Couplings • Suspension • Tube Clamp • Turbulator • Burner • U-Tubes • Tube Extension • Side Ext. Reflector</i>	4	pg 09
INSTALLATION: Venting and Ducting <i>General Requirements • Unvented Operation • Horizontal Venting • Vertical Venting • Common Venting • Outside Air Supply</i>	5	pg 19
INSTALLATION: Gas Piping <i>Sizing • Installation</i>	6	pg 25
INSTALLATION: Wiring <i>Line Voltage Thermostat Wiring • Low Voltage Thermostat Wiring • Burner Internal Wiring • Ladder Diagram</i>	7	pg 26
OPERATION/MAINTENANCE <i>Operation • Maintenance • Troubleshooting</i>	8	pg 30
APPENDICES <i>Replacement Parts • Specifications • Warranty</i>	9	pg 34

This page is intentionally blank.

WARNINGS**Section 1****⚠ WARNING ⚠****FAILURE TO FOLLOW THESE INSTRUCTIONS CAN CAUSE
PROPERTY DAMAGE, SEVERE INJURY OR DEATH:****FIRE OR EXPLOSION HAZARD: COMBUSTIBLES**

Failure to maintain the specified minimum clearances to combustibles could result in a serious fire hazard. Do not locate flammable or combustible materials within this distance. Do not locate in hazardous atmospheres containing flammable vapors or combustible dust. Installations in public garages or airplane hangars are permitted when in accordance with ANSI Z83.6 and NFPA-409 and 88 Codes.

FIRE OR EXPLOSION HAZARD: VEHICLES

Minimum clearances must be maintained from vehicles parked below the heater. Signs should be posted in storage areas to specify maximum stacking height to maintain required clearances to combustibles.

FIRE OR EXPLOSION HAZARD: GAS CONNECTION

There is an expansion of the radiant pipe with each firing cycle, and this will cause the burner to move with respect to the gas line. This can cause a gas leak resulting in an unsafe condition if the gas connection is not made strictly in accordance with Figure 18 of these instructions.

FIRE OR EXPLOSION HAZARD: IGNITION

This appliance does not have a pilot. It is equipped with an ignition device which automatically lights the burner. Do not try to light the burner by hand.

MECHANICAL HAZARD: SUSPENSION

Use appropriate suspension hardware, beam clamps (rod or perforated strap) and turnbuckles at predetermined locations. The weight and normal movement of the heating system may cause support failure if the following minimum suspension requirements are not met: distance between supports must be 10 ft. or less; chain size must be 2/0 minimum or equivalent. Failure of the supports can cause property damage, severe injury, or death.

IMPORTANT

**FAILURE TO FOLLOW THESE INSTRUCTIONS CAN CAUSE
PROPERTY DAMAGE OR PERSONAL INJURY.**

Do not use in an atmosphere containing halogenated hydrocarbons or other corrosive chemicals. Some compounds in the air can be drawn into the equipment and can cause an accelerated rate of corrosion of some parts of the heat exchanger. The use of such chemical compounds in or near the enclosure should be avoided where a longer life of the burner, tubing and other parts is desirable.

Caution should be used when running the system near combustible materials such as wood, paper, rubber, etc. Consideration should be given to partitions, storage racks, hoists, building construction, etc. Table 1, Section 3 gives **minimum** acceptable clearances to combustibles. Clearances as shown in Table 1 are not for use in four-sided enclosures.

If the building has a slight negative pressure or contaminants are present in the air, an outside combustion air supply to the heaters is strongly recommended.

CAUTION

**FAILURE TO FOLLOW THESE INSTRUCTIONS CAN CAUSE
DAMAGE TO THE SYSTEM COMPONENTS.**

Do not high pressure test the gas piping with the burners connected. Failure to follow this procedure will exceed the pressure rating of burner gas controls and this will require complete replacement of these parts.

This heater is designed for heating nonresidential indoor spaces. These instructions, the layout drawing, local codes and ordinances, and applicable standards such as apply to gas piping, electrical wiring, venting, etc., must be thoroughly understood before proceeding with the installation.

INTRODUCTION**Section 2**

Roberts-Gordon pioneered low-intensity infrared heating systems in 1962 with the introduction of its revolutionary custom-engineered Co-Ray-Vac system. Now Roberts-Gordon offers its 30 years of infrared expertise in a unitary heater. Vantage II models are low-cost, field assembled infrared heaters that are easy to install and require only minimal maintenance. They are designed to provide years of economical operation and trouble-free service.

Checking Shipment

Check the shipment against the Bill of Lading for shortages. Also, check for external damage to cartons. Note any shortages, and/or external damage to cartons on the Bill of Lading in the presence of the delivery trucker. The delivery trucker should acknowledge any shortages or damage by initialing this "noted" Bill of Lading. Immediately report any claims for damaged material, or shortages that were not evident at the time of shipment, to the carrier and your Roberts-Gordon Sales Representative.

Installer Responsibility

All heaters and associated gas piping should be installed in accordance with applicable specifications and this installation made only by firms (or individuals) well qualified in this type of work. Consult local building inspectors, Fire Marshals or your local Roberts-Gordon Representative for guidance.

Vantage II heaters are installed on the basis of information given in a layout drawing, which together with the cited codes and regulations, comprise the basic information needed to complete the installation. The installer must furnish all needed material that is not furnished as standard equipment, and it is his responsibility to see that such materials, as well as the installation methods he uses, result in a job that is workmanlike and in compliance with all applicable codes.

Roberts-Gordon Factory Representatives have had training and experience in the application of this equipment and can be called on for suggestions about installation which can save material and money.

The following codes and instructions should be followed when planning the installation of the Vantage II heater. In addition to these instructions, the warnings in Section 1 must be carefully adhered to since improper installation may lead to property damage, injury, or death.

National Standards and Applicable Codes

Gas Codes The type of gas appearing on the nameplate must be the type of gas used. Installation must comply with local codes and recommendations of the local gas company, and the *National Fuel Gas Code, ANSI Z223.1 - latest revision*, (same as NFPA Bulletin 54).

- Clearance between the heater and its vent and adjacent combustible material (which is part of the building or its contents) shall be maintained to conform with the *Standard for Installation of Gas Appliances and Gas Piping NFPA-54/ANSI-Z223.1 - latest revision, National Fuel Gas Code*.

Aircraft Hangars Installation in aircraft hangars must be in accordance with the *Standard for Aircraft Hangars, ANSI/NFPA-409 - latest revision*.

- Heaters in aircraft storage or service areas shall be installed at a height of 10 feet above the upper surface of wings or engine enclosures of the highest aircraft which may be housed in the hangar. (This should be measured from the bottom of the heater to the wing or engine enclosure, whichever is highest from the floor).
- In other sections of aircraft hangars, such as shops or office, heaters must not be installed less than eight feet above the floor.
- Heaters installed in aircraft hangars shall be located so as not to be subject to damage by aircraft, cranes, movable scaffolding or other objects.

Public Garages Installation in garages must be made in accordance with the *Standard for Parking Structures NFPA-88A - latest revision* or the *Standard for Repair Garages, NFPA 88B - latest revision*.

- Heaters must not be installed less than eight feet above the floor. Minimum clearances to combustibles must be maintained from vehicles parked below the heater.
- When installed over hoists, minimum clearances to combustibles must be maintained from the uppermost point on the hoist.

Electrical The heater must be electrically grounded in accordance with the *National Electrical Code, ANSI/NFPA-70 - latest revision*. Wiring must conform to the most current National Electrical Code, local ordinances, and any special diagrams furnished.

Venting The venting must be installed in accordance with *NFPA-54/ANSI-Z223.1 - latest revision, National Fuel Gas Code*. Partial information with regard to this code is provided in Section 5 of this installation manual with regard to size and configurations for venting arrangements.

Any portion of flue pipe passing through a combustible wall must be dual insulated or have an approved thimble. Refer to *ANSI Z223.1 - latest revision*.

Hazardous Locations Where there is the possibility of exposure to combustible airborne material or vapor, consult the local Fire Marshall, the fire insurance carrier or other authorities for approval of the proposed installation.

Critical Considerations

Vantage II is a suspended heater. Therefore, its stability, flexibility, and safety are very important. Before starting installation, be sure the system can meet the following requirements:

- Maintain specified clearances to combustibles, and safe distance from heat-sensitive material, equipment and work stations.
- Provide a suspension with vertical length of chain or swinging rod which has at least two inches of horizontal travel for each burner in a straight run. Be sure the suspension system is sufficiently flexible to accommodate thermal expansion which occurs as the system heats up (see Figure 5).
- Provide access to burners for servicing, preferably on both sides, above, and behind for burner removal.
- Provide for a minimum of 18 inches of clearance between burners and building walls. (Always observe minimum clearances to combustibles)
- Be sure the heater has a downward pitch of one-half inch per 20 feet away from the burner.
- Provide signs in storage areas to specify maximum stacking height to maintain required clearances to combustibles.
- Plan location of supports (see Figure 2). Locate a support near all elbows.

Installation Procedure

Take maximum advantage of the building upper structure, beams, joists, purlins, etc., from which to suspend the heater. There is no unique sequence for installation of the tubing. On-site observation will usually reveal a logical sequence. Begin the installation at the most critical dimension. This could save time. Watch for swinging doors, overhead cranes, car lifts, etc. Reflectors and tubing can be installed as you move along. Carefully adjust system pitch at each position to level the heater. Pitch down one-half inch in 20 ft. (away from burner).

- Don't**
 - Pressure test the gas line using high pressure (greater than 1/2 PSIG) without closing the high-pressure shutoff cocks. Failure to do so will result in damage to the burners.
- Do**
 - Familiarize yourself with local and national codes.
 - Develop a planned procedure which will conserve material and labor on the job.
 - Check to see that all material and equipment is on the job before starting installation.
 - Allow for thermal expansion of the hot tube.
 - Install the gas connector only as shown in instructions. (See Figure 18)
 - Have slip joints where required between reflectors to keep them from buckling or coming apart.
 - Provide one square inch of free air opening to each 1,000 BTU/hr of heater input (but not less than 100 square inches) in enclosed spaces. One opening should be within 12 inches of the top and one within 12 inches of the bottom of the enclosure.

CLEARANCES TO COMBUSTIBLES

TABLE 1: Minimum Clearances to Combustibles (Use Figure 1 as a guide)

Reflector Type	Position	CTH2-40	CTH2-60	CTH2-80	CTH2-100	CTH2-125	CTH2-150
Standard Reflector	A	4"	4"	4"	4"	4"	4"
	B	22"	30"	33"	35"	41"	45"
	C	50"	60"	63"	68"	74"	77"
	D	22"	30"	33"	35"	41"	45"
45° Reflector Tilt	A	4"	4"	4"	6"	6"	8"
	B	4"	4"	4"	4"	4"	4"
	C	45"	54"	60"	68"	72"	78"
	D	42"	50"	56"	60"	65"	70"
One Side Extension	A	4"	4"	4"	4"	4"	4"
	B	4"	4"	4"	4"	4"	4"
	C	50"	60"	67"	74"	80"	83"
	D	39"	42"	49"	54"	60"	64"
Two Side Extensions	A	4"	4"	4"	6"	6"	8"
	B	10"	18"	20"	22"	27"	30"
	C	50"	63"	69"	74"	81"	85"
	D	10"	18"	20"	22"	27"	30"
U-Tube, Standard	A	-	4"	4"	4"	4"	4"
	B	-	30"	33"	35"	41"	45"
	C	-	60"	66"	73"	76"	81"
	D	-	25"	32"	34"	38"	42"
U-Tube, Opposite 45°	A	-	4"	4"	6"	6"	8"
	B	-	50"	56"	60"	66"	70"
	C	-	54"	60"	68"	72"	78"
	D	-	18"	18"	18"	18"	18"
U-Tube, Full 45°	A	-	4"	4"	6"	6"	8"
	B	-	4"	4"	4"	4"	4"
	C	-	54"	60"	68"	72"	78"
	D	-	38"	42"	48"	57"	62"
Unvented	Above	12"	12"	18"	18"	18"	18"
	End	18"	18"	24"	24"	24"	30"
Vented	End	18"	18"	18"	18"	18"	18"

⚠ WARNING ⚠

FIRE OR EXPLOSION HAZARD

In all situations clearances to combustibles must be maintained. Failure to observe clearances to combustibles may result in property damage, severe injury, or death.

Minimum clearances must be maintained from vehicles parked below the heater. Signs should be posted in storage areas to specify maximum stacking height to maintain required clearances to combustibles.

Caution should be used when running the system near combustible materials such as wood, paper, rubber, etc.. Consideration should be given to partitions, storage racks, hoists, building construction, etc..

Table 1 gives **minimum** acceptable clearances to combustibles. Clearances as shown in Table 1 are not for use in four-sided enclosures.

FIGURE 1: Clearances to Combustibles (Refer to Table 1)

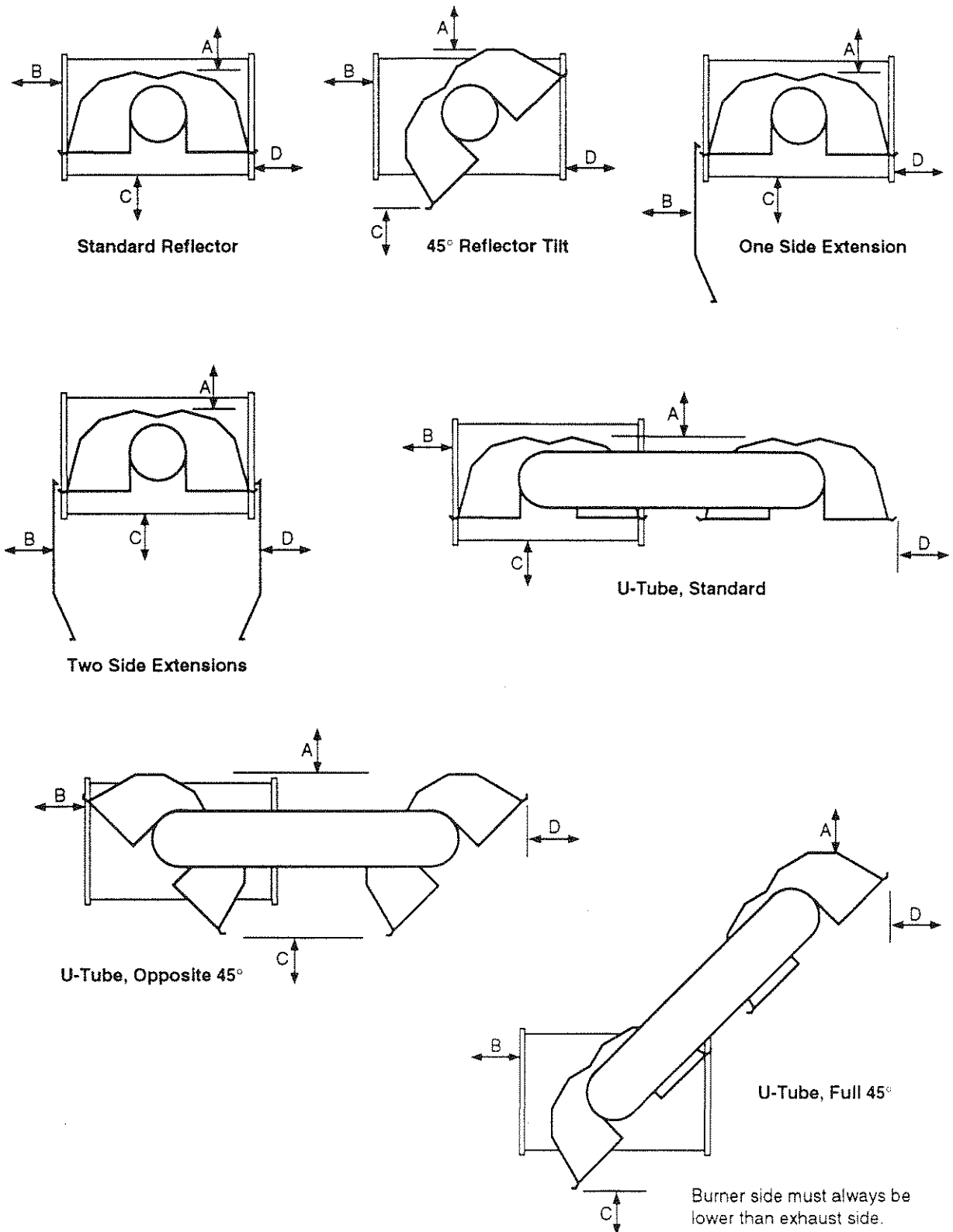

TABLE 2: Vantage II Standard Parts List

Part No.	Contents of Vantage II Burner Shipping Carton	CTH2-40	-60	-80	-100	-125	-150
03010800	Vantage II Burner 40,000 Btu/Hr Natural	1	-	-	-	-	-
03010900	Vantage II Burner 40,000 Btu/Hr LP	1	-	-	-	-	-
03010600	Vantage II Burner 60,000 Btu/Hr Natural	-	1	-	-	-	-
03010700	Vantage II Burner 60,000 Btu/Hr LP	-	1	-	-	-	-
03010400	Vantage II Burner 80,000 Btu/Hr Natural	-	-	1	-	-	-
03010500	Vantage II Burner 80,000 Btu/Hr LP	-	-	1	-	-	-
03010200	Vantage II Burner 100,000 Btu/Hr Natural	-	-	-	1	-	-
03010300	Vantage II Burner 100,000 Btu/Hr LP	-	-	-	1	-	-
03010000	Vantage II Burner 125,000 Btu/Hr Natural	-	-	-	-	1	-
03010100	Vantage II Burner 125,000 Btu/Hr LP	-	-	-	-	1	-
03011100	Vantage II Burner 150,000 Btu/Hr Natural	-	-	-	-	-	1
03011200	Vantage II Burner 150,000 Btu/Hr LP	-	-	-	-	-	1
02568200	Gasket (Burner to Transition Tube)	1	1	1	1	1	1
130100US	Installation Manual	1	1	1	1	1	1
91201708	Pipe Nipple (Black) 1/2 x 4	1	1	1	1	1	1
91412200	Flexible Gas Connector Assembly	1	1	1	1	1	1
94273914	Hex Head Cap Screw 5/16 - 18 - 2A x 7/8	4	4	4	4	4	4
96411600	Split Lockwasher	4	4	4	4	4	4

Part No.	Contents of Vantage II Accessory Package	CTH2-40	-60	-80	-100	-125	-150
03051100	Transition Tube, Aluminized	-	1	1	1	1	1
03051600	Transition Tube, Heat-Treated Aluminized	1	-	-	-	-	-
91409300	Tube, Hot Rolled Steel, 16 Ga., 10 ft.	-	1	1	2	3	4
91409408	Tube, Heat Treated Aluminized, 16 Ga., 10 ft.	-	1*	1*	2*	3*	4*
03051503	Turbulator Adapter	1	1	1	1	-	-
03051504	Turbulator 2.5 ft Section Piece	3	4	4	2	-	-
01312700	Plain Coupling Assembly	-	1	1	2	3	4
02750303	Standard 8 ft. Reflector	2	3	3	4	6	7
02754600	End Cap	2	2	2	2	2	2
03090100	Tube and Reflector Hanger	2	3	3	4	5	6
91907302	S-Hook	2	3	3	4	5	6
03050000	Reflector Support Strap (For Support Package)	1	2	2	3	5	6
91908004	Wire Form (For Support Package)	1	2	2	3	5	6
93420812	Sheet Metal Screws #8 x 3/4" (For Support Package)	2	4	4	6	10	12
01318901	Tube Clamp Package	1	1	1	1	1	1
91107720	U-Clip Package	1	1	1	1	1	1
90502700	Flue Pipe Adapter	1	1	1	1	1	1

* Vantage II heaters may be ordered with all aluminized tubing.

ASSEMBLY Section 4

FIGURE 2: *Vantage II Overview Key*

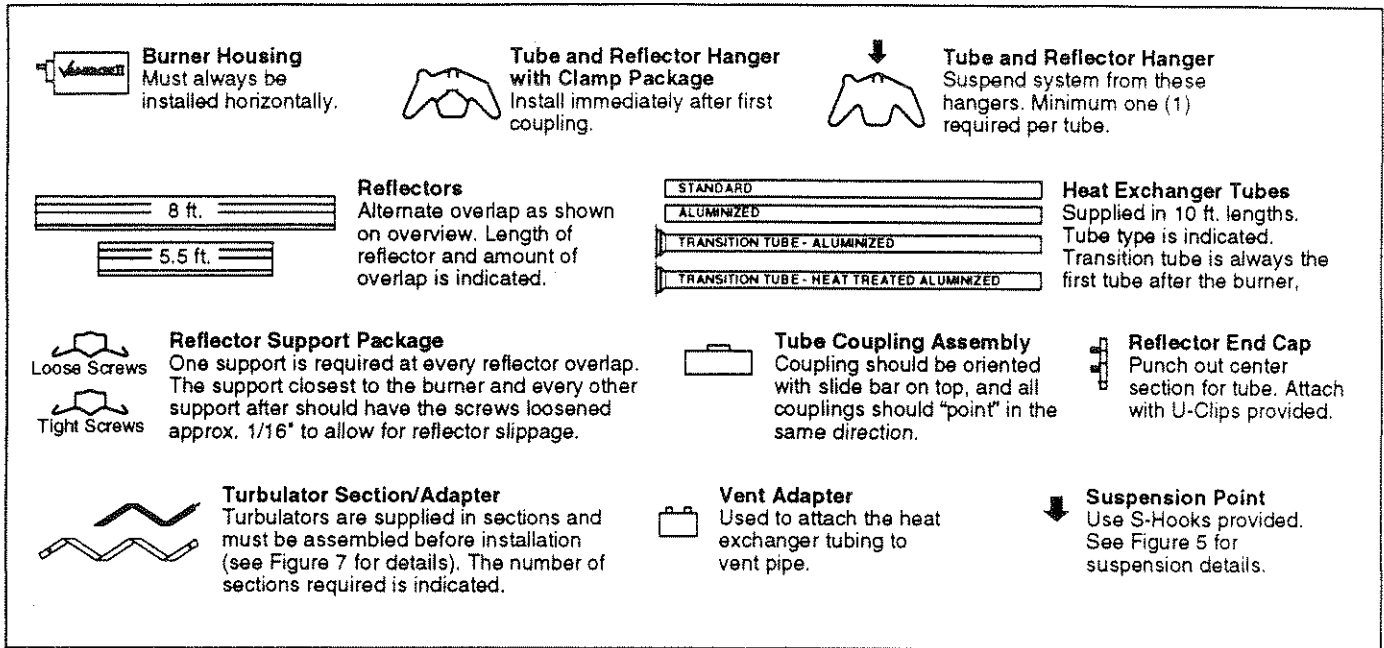

FIGURE 2a: *Vantage II Model CTH2-40 Assembly Overview*

10 ft. heat exchanger length. 11 ft.-10 in. total heater length. 2 suspension points as indicated.

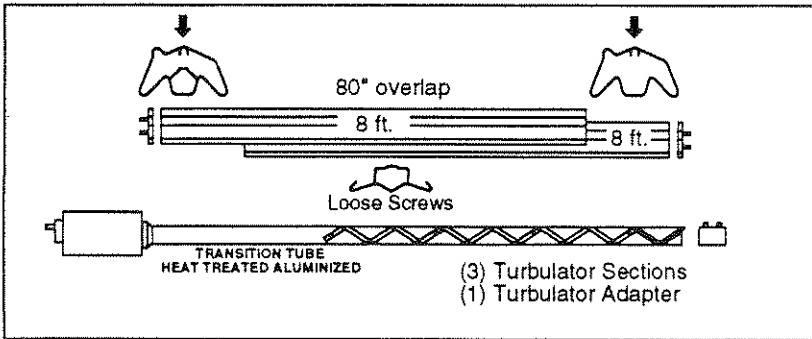

FIGURE 2b: *Vantage II Model CTH2-60, CTH2-80 Assembly Overview*

20 ft. heat exchanger length. 21 ft.-4 in. total heater length. 3 suspension points as indicated.

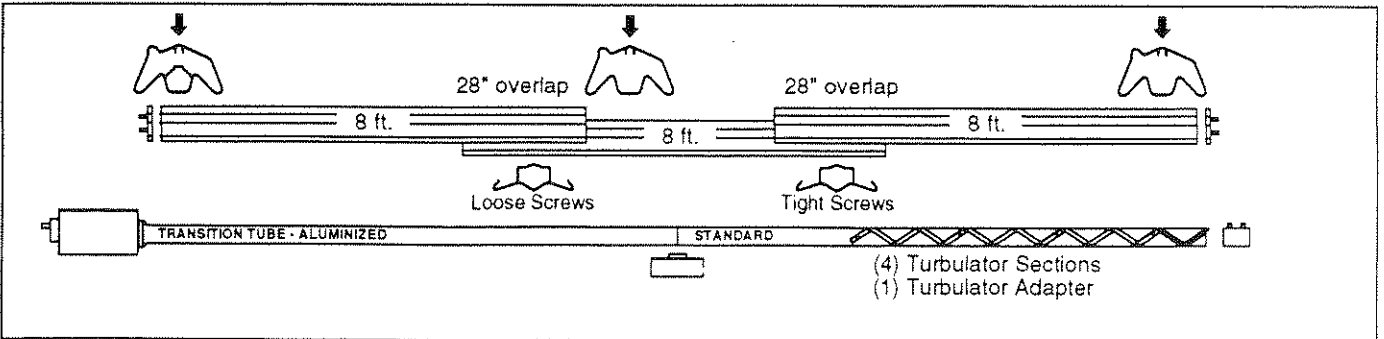
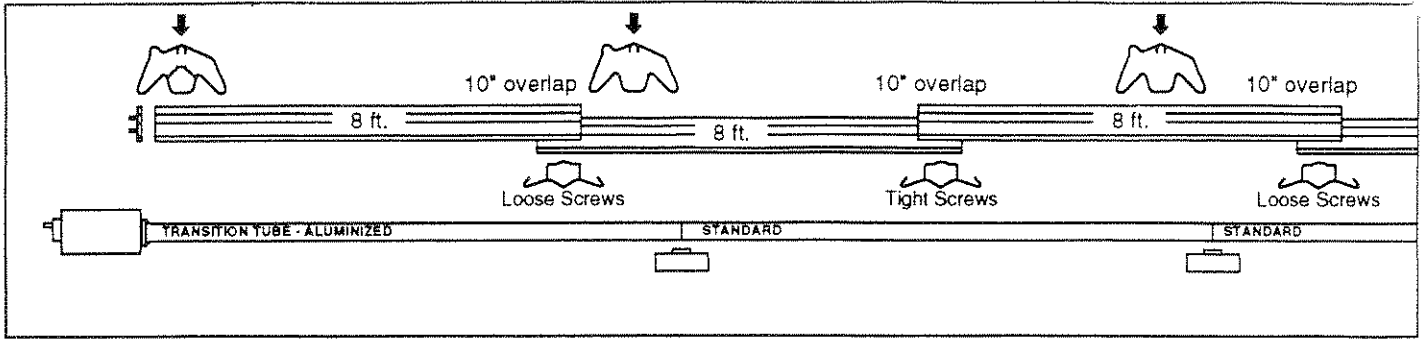

FIGURE 2c: Vantage II Model CTH2-100 Assembly Overview

30 ft. heat exchanger length. 31 ft.-4 in. total heater length. 4 suspension points as indicated.



continued on next page

FIGURE 2d: Vantage II Model CTH2-125 Assembly Overview

40 ft. heat exchanger length. 41 ft.-4 in. total heater length. 5 suspension points as indicated.

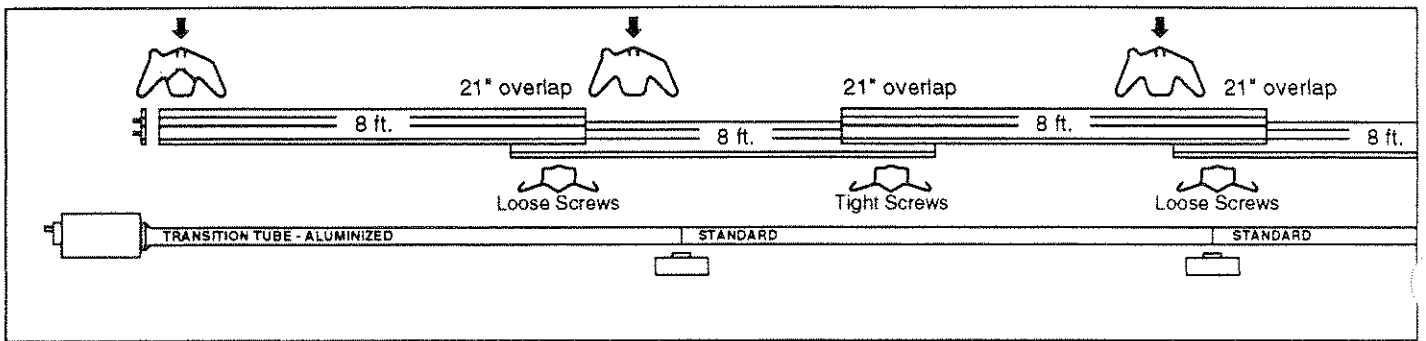

continued on next page

FIGURE 2e: Vantage II Model CTH2-150 Assembly Overview

50 ft. heat exchanger length. 51 ft.-4 in. total heater length. 6 suspension points as indicated.

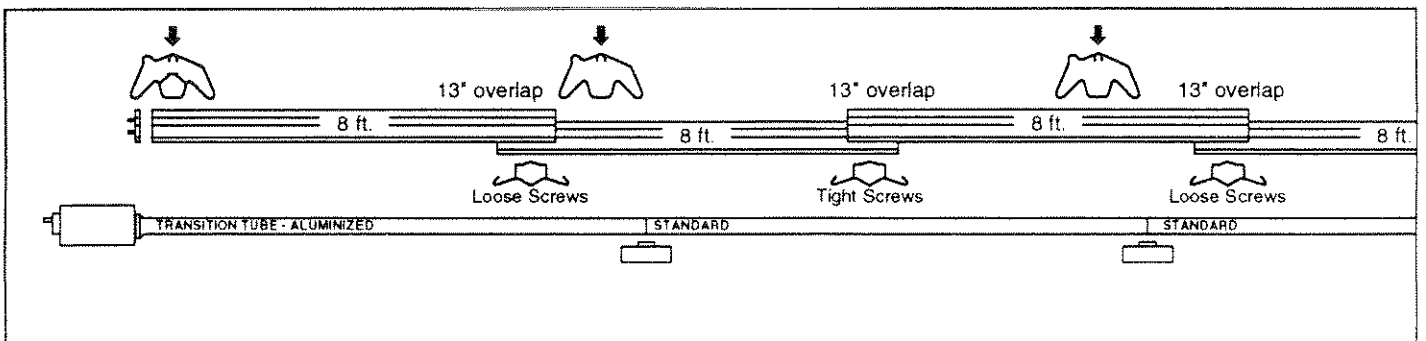

continued on next page

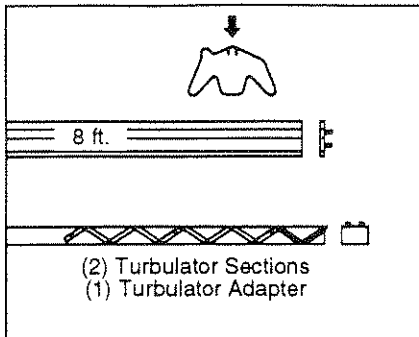

continued from previous page

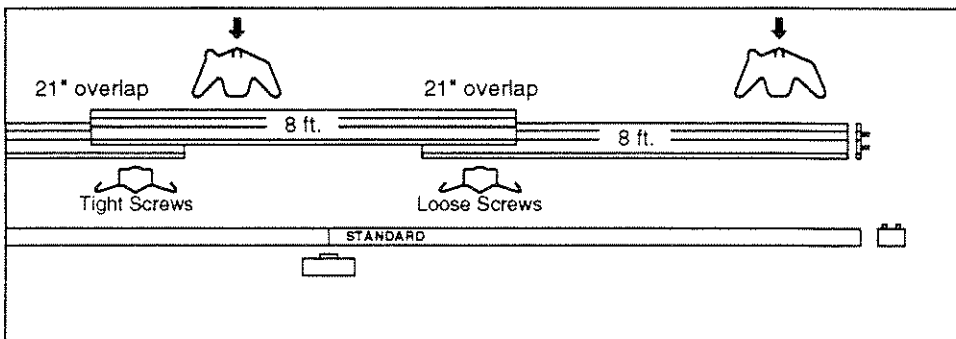

continued from previous page

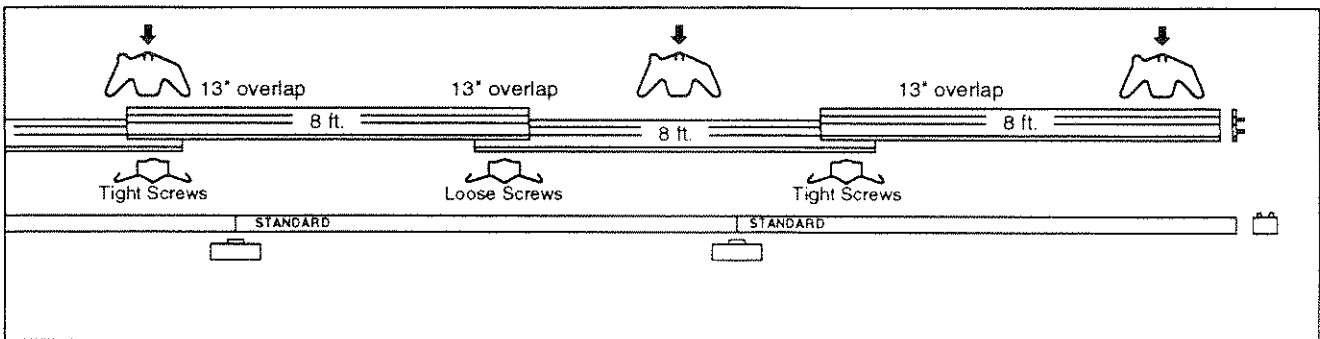

continued from previous page

ASSEMBLY (continued)**Section 4**

Assemble the heater components as shown in Figures 2A, 2B, 2C, 2D, and 2E. Optional reflector configurations are shown in Figure 1. Install appropriate suspension hardware, beam clamps, chain or rod at predetermined locations. Adjustment of chain length will provide uniform pitch.

Couplings Tube and tube fittings are connected by wrap-around couplings which clamp by means of a tapered, hammer-driven lock member. The starting ends of the coupling and lock member are identified by 1/4" holes which are put together when starting assembly. Be sure the tube ends are in line and tube ends butt against stop pin(s) inside coupling. The slide bar is to be hammer-driven to a point of securing the coupling snugly to the tubes. Over driving will result in distortion of the coupling or slide bar lip to a point decreasing the holding capability of the coupling. Coupling should be tight when the slide bar is $\pm 2"$ from the end of the coupling. See Figure 3.

FIGURE 3: Coupling Assembly

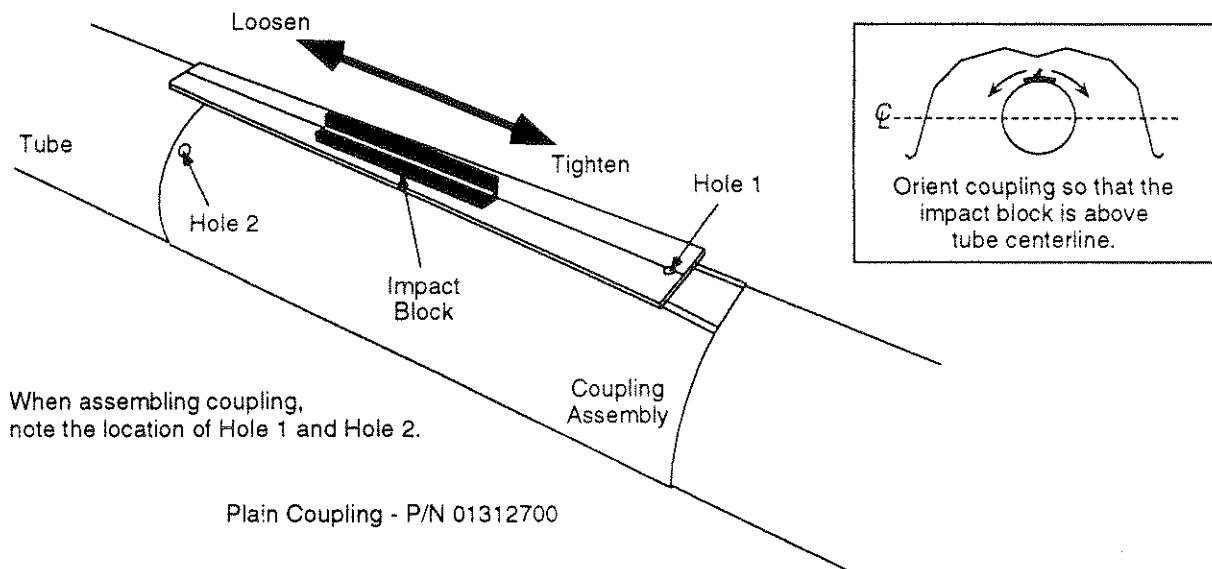

Elbow Package (P/N 02718702) Elbow Package includes: (1) elbow, (1) coupling, (1) end cap, and (1) reflector joint piece. Install elbow into radiant tube sequence where plans indicate a 90° bend. Install reflector joint piece using the following procedure (see Figure 4):

1. Flatten reflector edge where joint piece matches. Put a mark on the reflector, directly over the tube center. Center the accessory joint piece on the mark and scribe its contour on the reflector. Scribe the location of the mounting holes.
2. Cut away the reflector to clear the tube, leaving about one inch of material inside the scribed contour to attach the accessory joint. With an awl or other pointed tool, punch $\approx \frac{3}{32}$ " diameter holes in reflector.
3. Use six No. 10 sheet metal screws to attach the joint piece.

FIGURE 4: Installation of Elbow and Reflector Joint Piece (optional equipment)

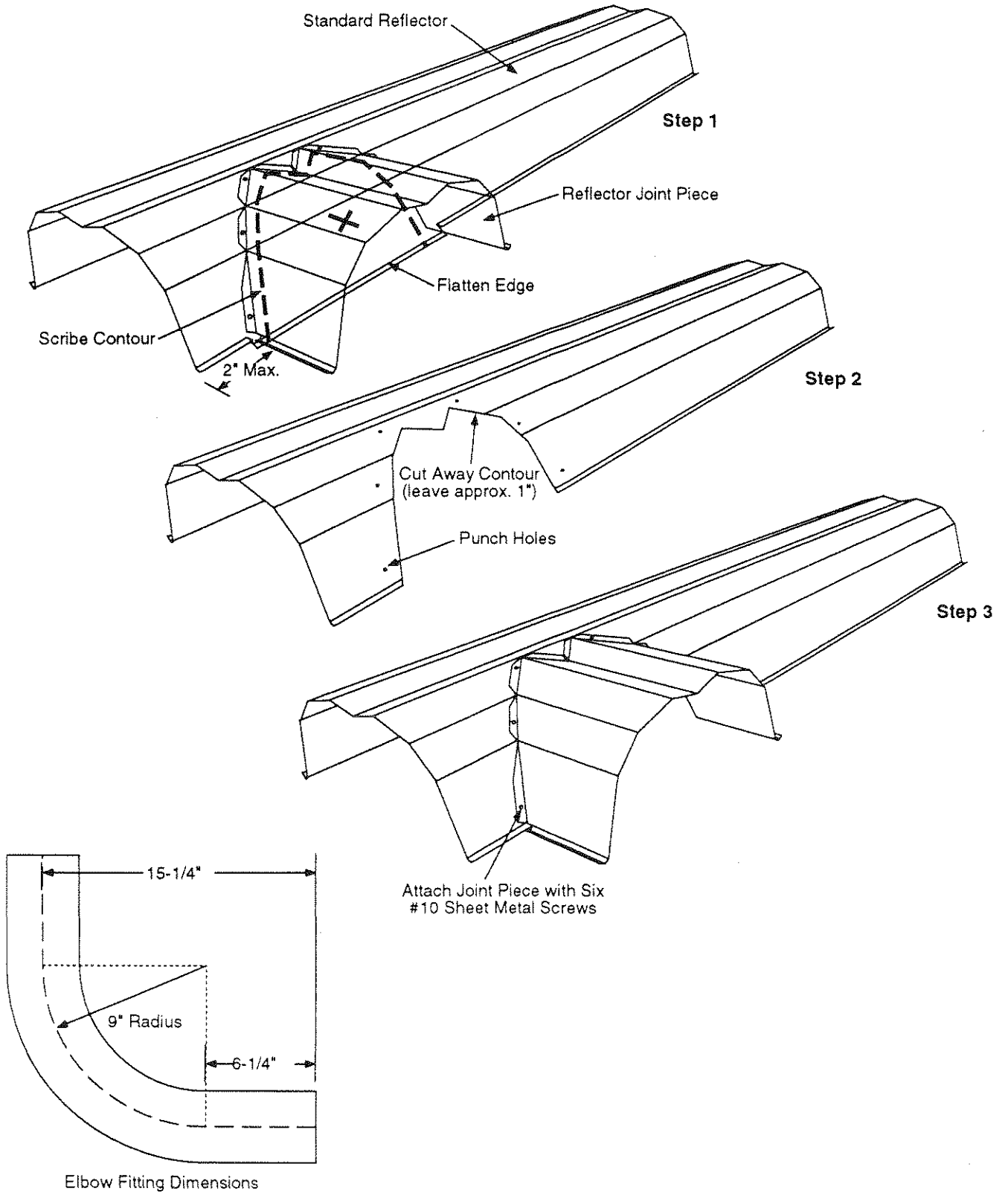

FIGURE 5: Typical Suspension Details

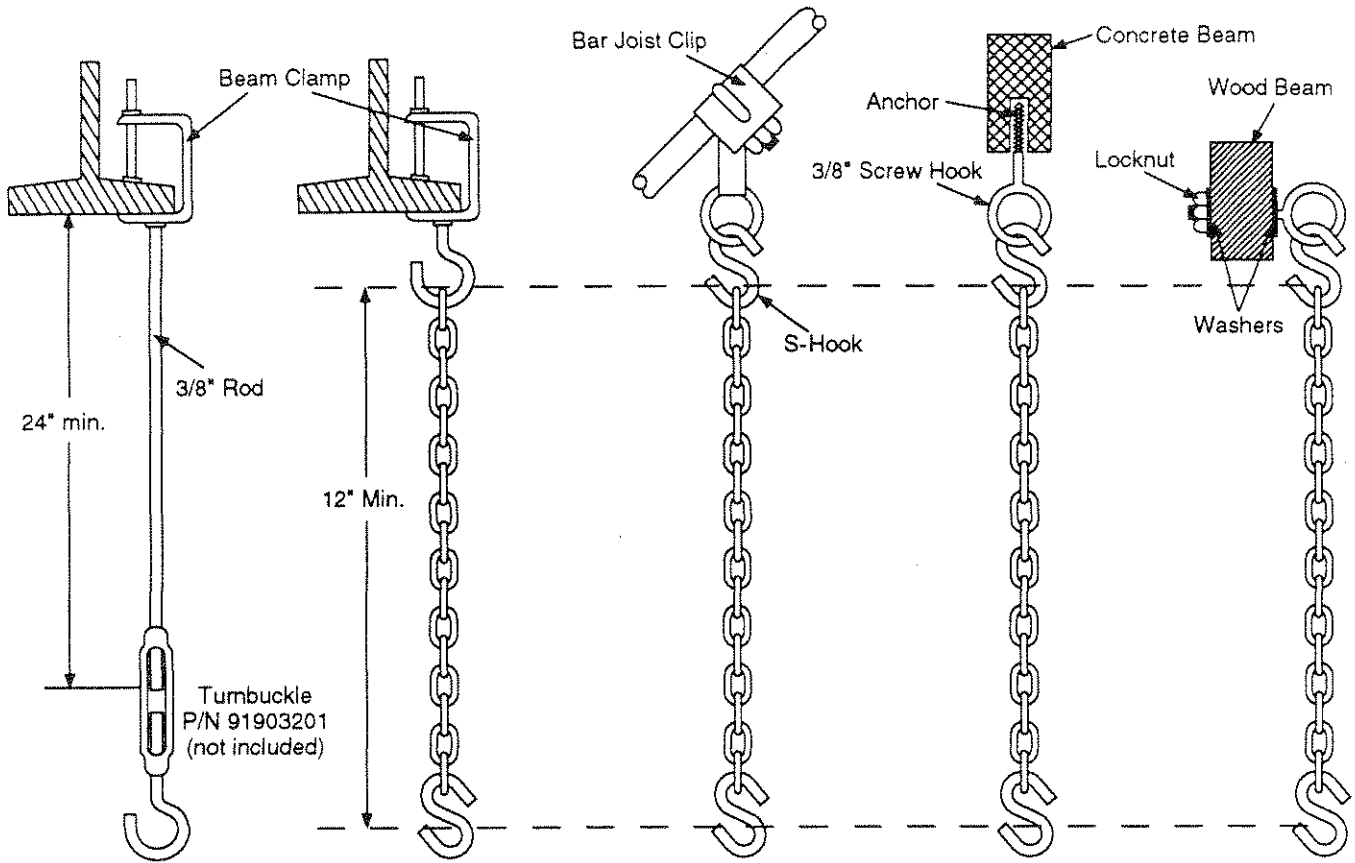

FIGURE 6: Tube Clamp Package Detail

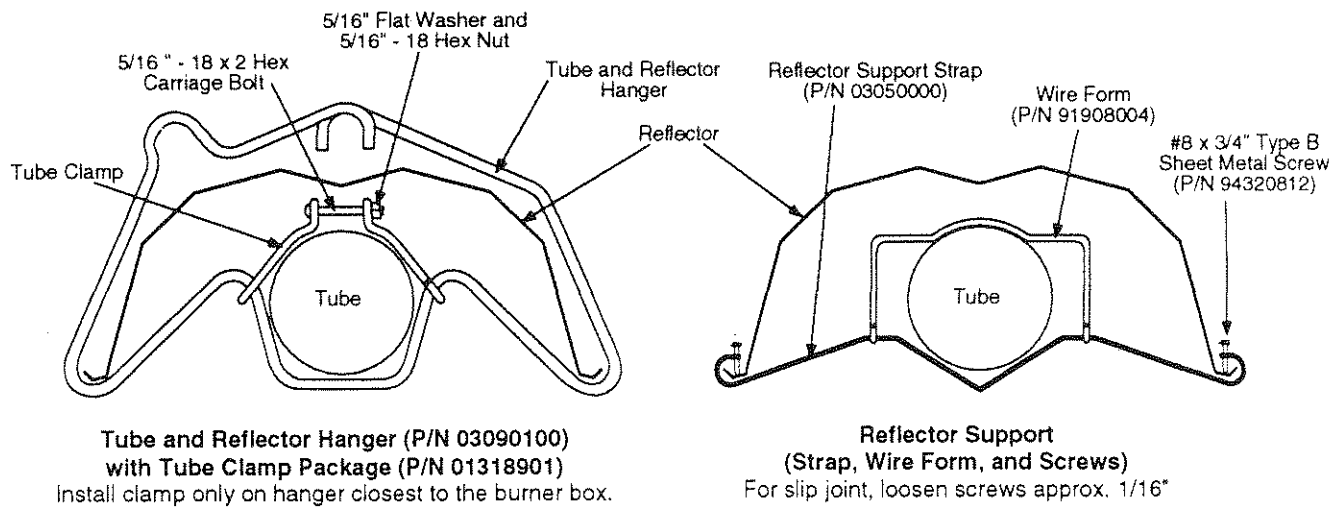
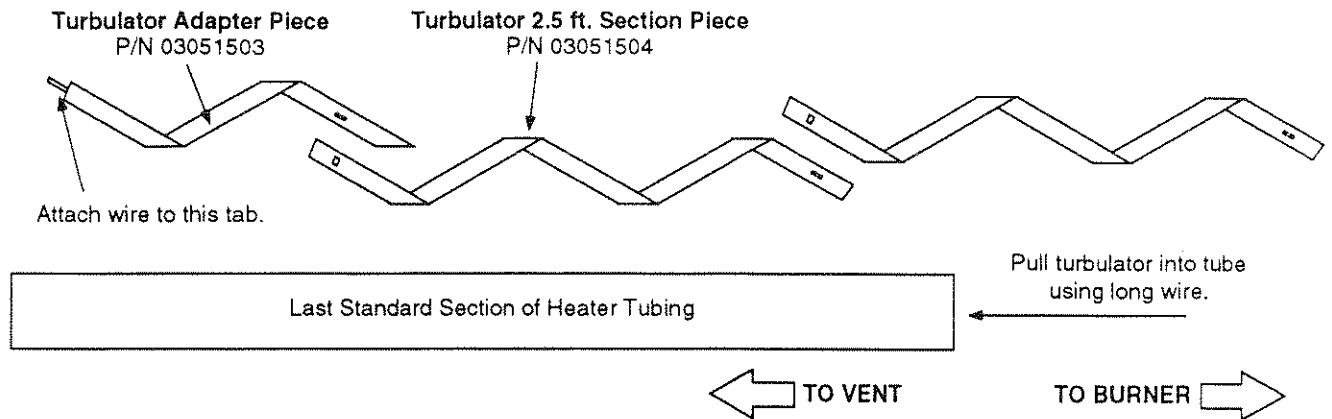

FIGURE 7: Turbulator Baffle Assembly Detail



For ease of installation, the turbulator should be installed in the tube before hanging the system.

Use the following procedure:

1. Assemble turbulator pieces by "twisting" matching ends together.
2. Insert a long wire (11 ft. minimum) down the length of the tube.
3. Attach the wire to the hole in the tab on the adapter piece.
4. Using the wire, pull the assembled turbulator into the tube from the opposite end.
5. Pull the turbulator through until just the tab comes out. Detach the wire.
6. Bend the tab around the tubing. When installing the tube, the tab will be locked in place by the flue adapter.

FIGURE 8: Burner Box/Transition Tube Detail

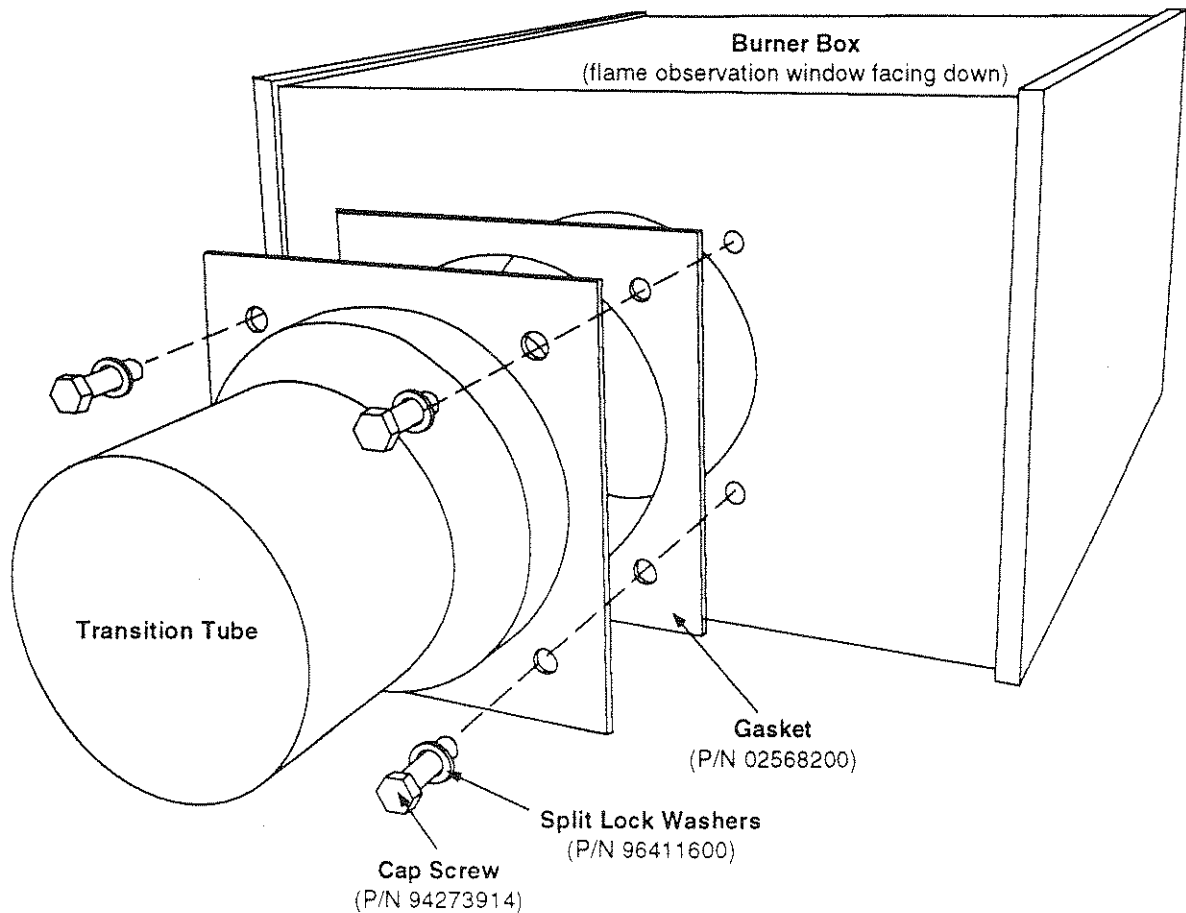

U-Tube Package

Vantage II heaters (except CTH2-40) are approved for optional U-Tube configurations. The U-Tube Package (P/N 03011000) includes: (1) 180° U-Tube, (1) Plain Coupling, (1) Tube and Reflector Hanger, (2) End Caps, (1) U-Tube Support Bracket and (2) 4" U-Bolts with Lockwashers and Hex Nuts.

Shown below is an example CTH2-100 U-Tube configuration. One of the 10 ft. tubes was cut in half to balance the sides. (The layout does not need to be symmetrical.) One (1) additional coupling was needed to complete the installation. The U-Tube may be installed in either a standard horizontal position or in an opposite 45° position as shown below. When designing a U-Tube configuration, the following rules must be adhered to:

1. A minimum of 10 ft. on CTH2-60/80 and a minimum of 15 ft. on CTH2-100/125/150 is required between the burner and the U-Tube.
2. The correct turbulator must be installed in the last standard section of heater tube.
3. The burner must never be operated in a tilted position.
4. The heater must be properly supported at all locations.

FIGURE 9: U-Tube Package Assembly Overview (optional)

Use Figure 2 as a guide to the symbols used.

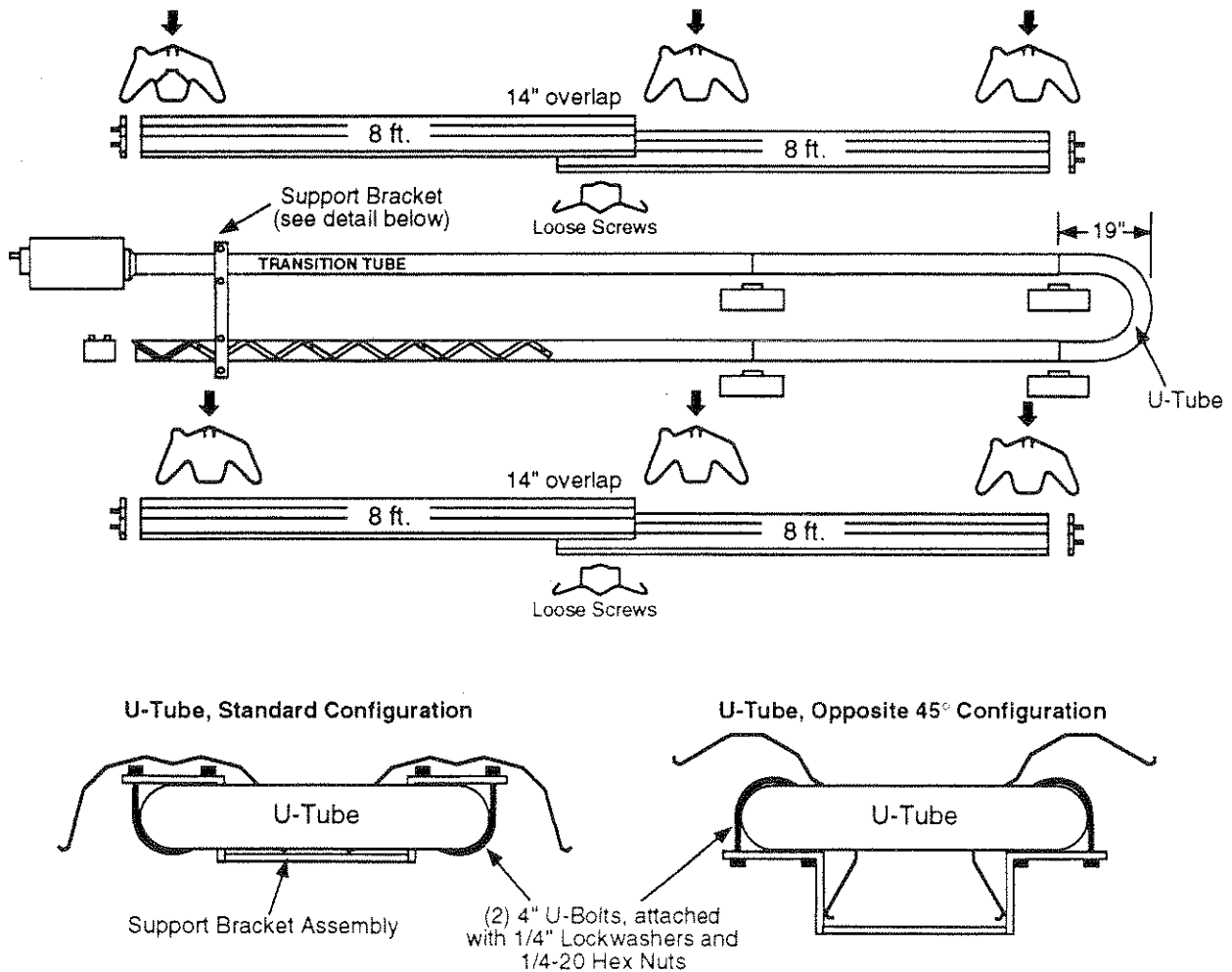

Extension Packages

Vantage II heaters are approved for configuration with extension packages to increase the heat exchanger length. The following table shows the configurations possible with extension packages:

Model	Heat Exchanger Length		
	Minimum (as supplied)	with 10 ft. Extension	Turbulator
CTH2-40	10 ft.	N/A	7 ft.
CTH2-60	20 ft.	N/A	10 ft.
CTH2-80	20 ft.	30 ft.	10 ft.
CTH2-100	30 ft.	40 ft.	5 ft.
CTH2-125	40 ft.	50 ft.	none
CTH2-150	50 ft.	60 ft.	none

The assembled turbulator (if required) must be installed in the last standard section of tubing and *not* in the extension tubing.

10 ft. Extension Pkg. (Hot Rolled P/N 02519201, Aluminized P/N 02519202) Includes:
 (1) 10 ft. Tube, (2) Std. Reflectors, (1) Hanger, (2) Reflector Supports, and (1) Coupling.

FIGURE 10: 10ft. Extension Package Assembly Detail. (Use Figure 2 as a guide to the symbols)

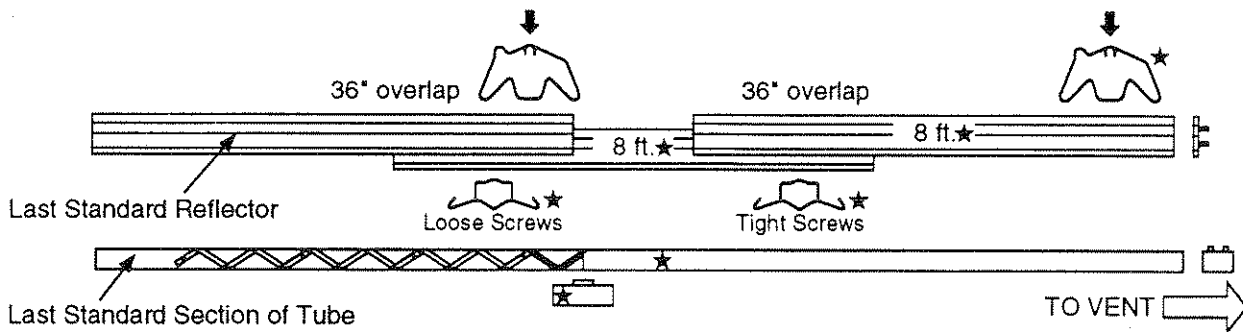

Items marked with a star (★) are included in the 10 ft. Extension Package. The turbulator (if required) must be installed in the last standard section of tube and *not* in the extension tubing.

Side Extension Reflector

Optional Side Extension Reflectors may be installed on either side of the unit. Each 8 ft. section of Side Reflector should match a reflector and have identical overlap to adjacent reflectors. Provide slip joints in the same locations as the reflectors. Proceed as follows:

1. Attach a reflector side extension support bracket to the tubes where needed. These brackets should be located adjacent to the overlapped joints of the reflectors.
2. Insert lower edge of reflector side extension in extension support bracket.
3. Cut suitable relief notches where the side extension reflector meets tube and reflector hangers and reflector support brackets.
4. Hook the top edge of the side extension reflector over the edge of the reflector.
5. A slip joint must be provided in the perimeter side extension at the location of each slip joint in the reflector. The overlap should be the same as the reflector.
6. Where severe air movement may be encountered, as at large door, one or two sheet metal screws should be used to attach the side extension reflectors together.
7. **To Install the Retainer Clips:** Lay bracket over the side extension reflector and standard reflector at the selected location. By using the hole in the clip as a template, drill or punch a $\frac{3}{8}$ " diameter pilot hole in the standard reflector. Secure the retainer clip using #8 x $\frac{3}{8}$ " sheet metal screws.

FIGURE 11: Installation of Side Extension Reflectors

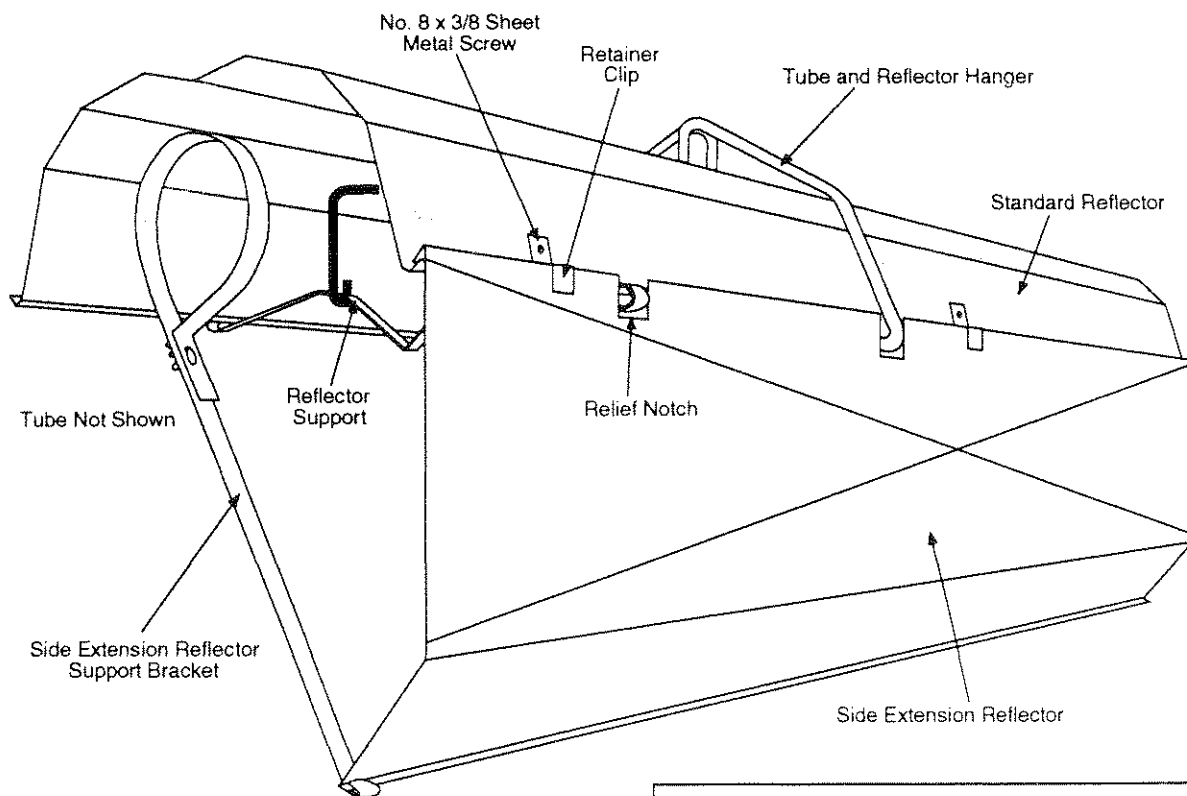

Reflector Side Extension Package (P/N 02712700) includes: (1) Side Extension Reflector, (2) Retainer Clips and (2) Sheet Metal Screws. Order at least (2) Side Extension Reflector Support Brackets (P/N 01329900) for each package.

VENTING/DUCTING**Section 5***General Requirements*

Heater must be vented in accordance with specification ANSI Z223.1 - latest revision. Partial information relating to this specification is provided in this section with regard to size and configurations for venting arrangements (see Figures 12,13,14,15,16). For complete information consult ANSI Z223.1 - latest revision and applicable local codes. Use the following guidelines to help insure an adequate, safe venting arrangement:

- a. Be sure that method selected for venting heater complies with all codes as required for each particular location.
- b. Exhaust end of heater will accept a four inch flue pipe using the flue pipe adapter.
- c. Heater may be vented to the outdoors either vertically or horizontally.
- d. If heater is to be vented horizontally:
 1. Vent must exit building not less than seven feet above grade when located adjacent to public walkways.
 2. Vent must terminate at least three feet above any forced air inlet located within ten feet.
 3. Vent must terminate at least four feet below, four feet horizontally from, or one foot above any door, window, or gravity inlet into any building.
 4. Vent terminal shall be located at least 12 inches from any opening through which vent gases could enter a building.
- e. Vent terminal opening must be beyond any combustible overhang.
- f. If condensation in the flue is a problem, the flue length should be shortened or insulated.
- g. For vent specifications all of the following conditions must be met:
 1. Maximum total vent length allowed is 45 feet.
 2. Maximum outside air supply duct allowed is 45 feet.
 3. Maximum total vent length plus outside air supply length plus extension package shall not exceed 65 feet.
 4. Under length conditions 1) through 3) above, a total of 2 elbows are allowed for vent and outside air supply together. Subtract 15 feet per additional elbow from maximum length allowed if more than 2 elbows are used.

Alternative Arrangements/Optional Equipment for Venting

- For unvented operation:**
- a. Sufficient ventilation must be provided in the amount of 4 cfm per 1000 BTU/hr firing rate.
 - b. Refer to ANSI Z223.1 - latest revision (NFPA No. 54) and local codes for additional information.
 - c. Use of optional outside combustion air is not recommended with unvented heaters due to pressure considerations.

- For horizontal venting:**
- a. In combustible or noncombustible walls use Tjernlund VH1-4" (P/N 90502100.) Follow vent manufacturer's instructions for proper installation. (Alternative vent Roberts-Gordon P/N 02537800, noncombustible wall only.)
 - b. 4" O.D. flue pipe is required, 30 feet maximum length is recommended. Up to 45 feet maximum may be used if insulated to prevent excess condensation. (See *General Requirements* on pg. 19 for additional information.)
 - c. All flue joints should be sealed using suitable product such as General Electric RTV106 or Permatex Form-a-Gasket Red High Temperature Silicone Adhesive Sealant.
 - d. Vent terminal should be installed at a height sufficient to prevent blockage by snow.
 - e. Building materials should be protected from degradation by flue gases.

- For vertical venting:**
- a. 4" O.D. flue pipe, maximum 45 feet in length may be used as shown with an approved vent cap. (See *General Requirements* on pg. 19 for additional information.)
 - b. An insulating thimble may be required to pass through combustible structures (check local codes).
 - c. All flue joints should be sealed using suitable products (see recommendation for horizontal venting).

- Venting with draft hood:**
- a. Refer to ANSI Z223.1 - latest revision (NFPA No. 54) for heights and vent sizes recommended for proper venting. (Check local codes for additional information).
 - b. Minimum six-inch O.D. vent is recommended.

- For common venting:**
- a. Horizontal run to vent must never exceed 75% of the vertical height of the vent. (Refer to ANSI Z223.1 - latest revision, (NFPA No. 54) for proper vent sizes and installation.)
 - b. Open area of common vent must equal the sum of the open area of individual flue vents connected to it (see chart on diagram).
 - c. Use double wall vent as required (check codes).
 - d. Heaters sharing a common vent must be controlled by the same thermostat.
 - e. All joints must be sealed using suitable products (see recommendation for horizontal venting).
 - f. Connections to common stack must be positioned to avoid direct opposition between streams of combustion gases.

Outside Air Supply: See procedure and diagram on pg. 24.

FIGURE 12: Unvented Operation

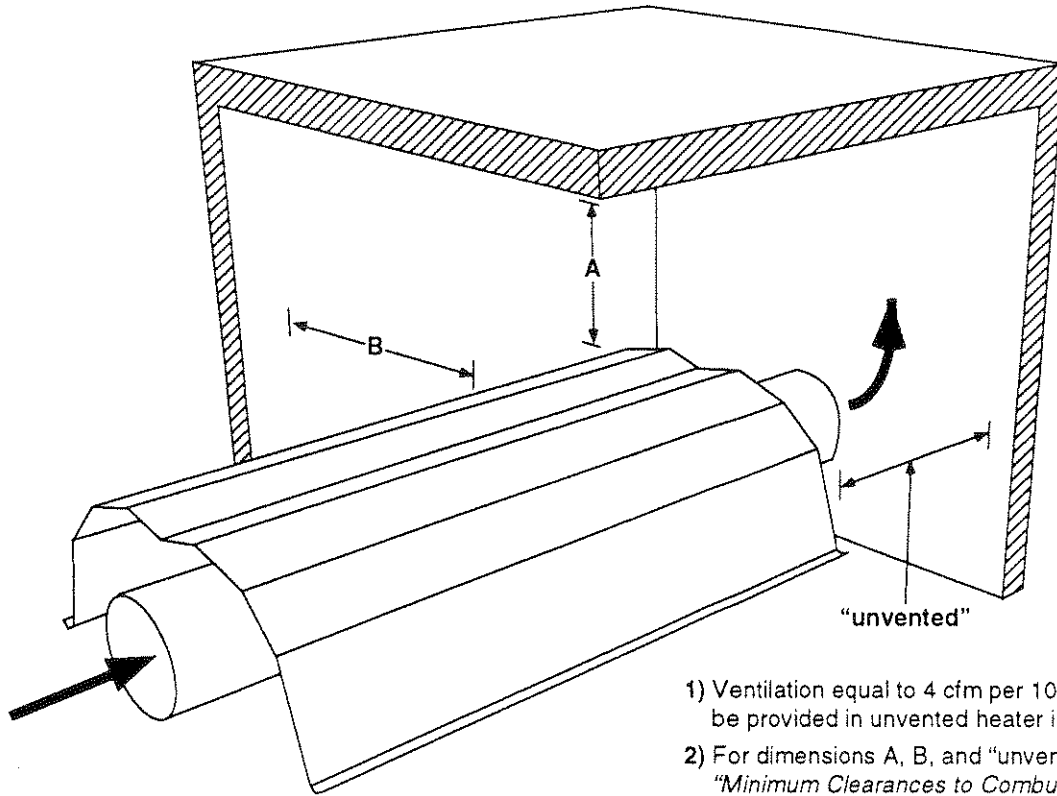

- 1) Ventilation equal to 4 cfm per 1000 BTU/hr firing rate must be provided in unvented heater installations.
- 2) For dimensions A, B, and "unvented" refer to Figure 1: "Minimum Clearances to Combustibles."

FIGURE 13a: Horizontal Venting - Combustible Walls

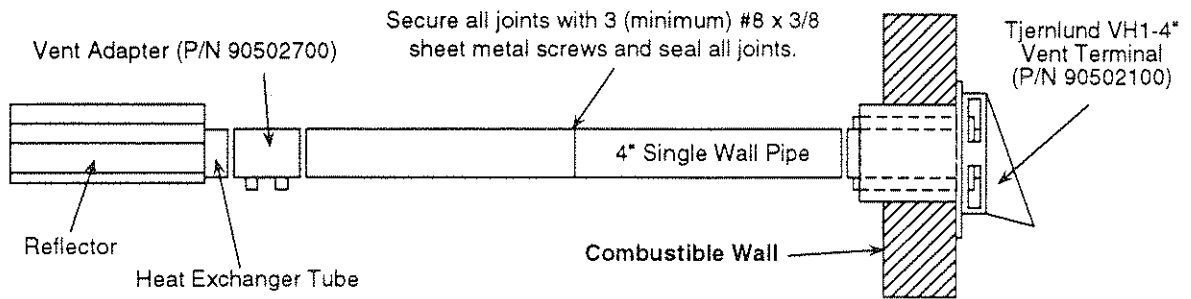

FIGURE 13b: Horizontal Venting - Noncombustible Walls

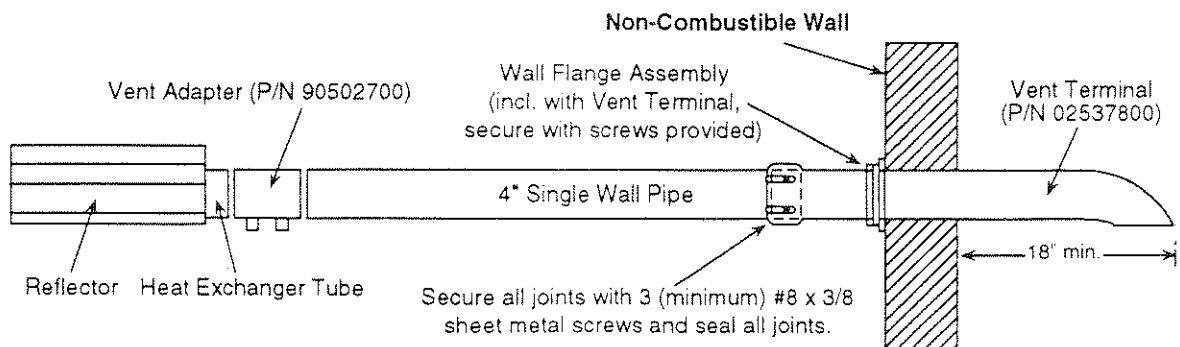

FIGURE 14: Vertical Venting

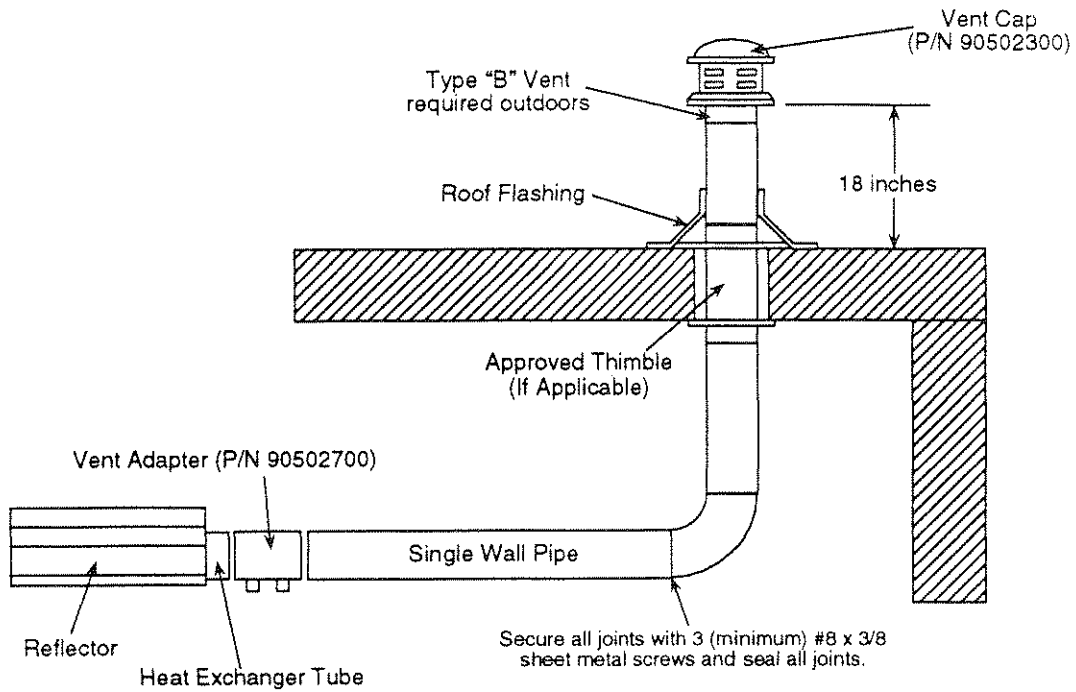

FIGURE 15: Vertical Venting with Draft Hood

WARNING:
The Draft Hood must not be used with an outside combustion air supply.

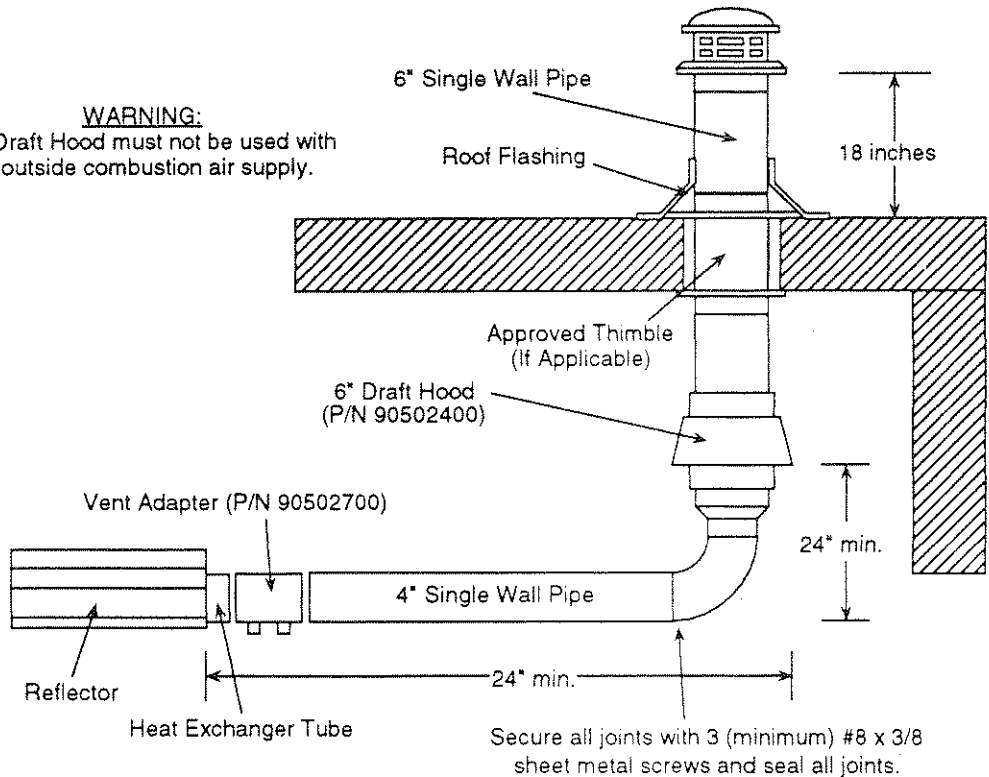
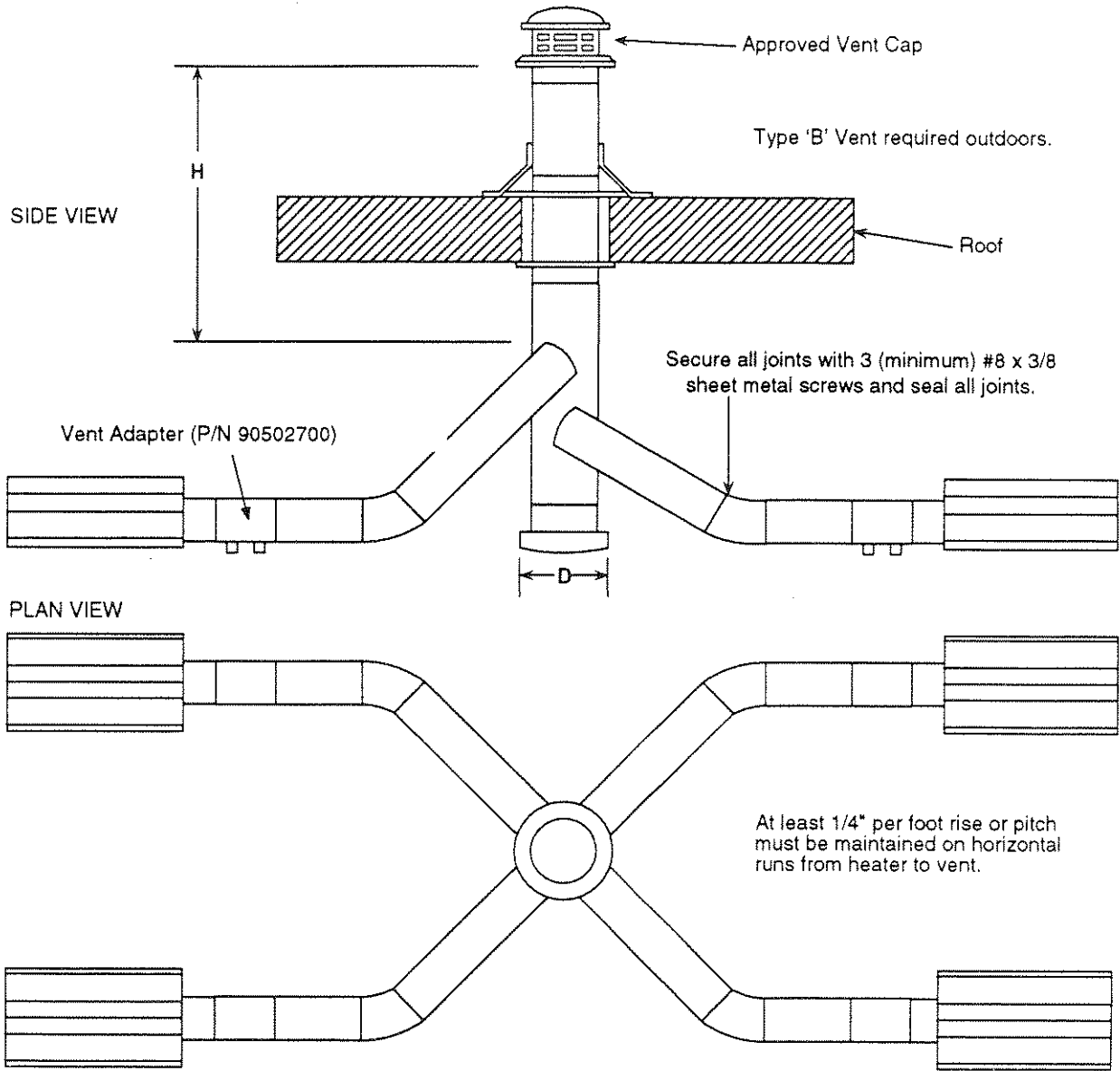

FIGURE 16: Common Roof Venting



COMMON VENTING - 2 HEATERS:

Model #	H = 6ft.	H = 8ft.	H = 15ft.
CTH2-40	D = 6"	D = 5"	D = 5"
CTH2-60	D = 7"	D = 6"	D = 6"
CTH2-80	D = 8"	D = 7"	D = 6"
CTH2-100	D = 8"	D = 8"	D = 7"
CTH2-125	D = 10"	D = 10"	D = 8"
CTH2-150	D = 10"	D = 10"	D = 8"

COMMON VENTING - 4 HEATERS:

Model #	H = 6ft.	H = 8ft.	H = 15ft.
CTH2-40	D = 8"	D = 7"	D = 6"
CTH2-60	D = 10"	D = 10"	D = 8"
CTH2-80	D = 10"	D = 10"	D = 10"
CTH2-100	N/A	D = 12"	D = 10"
CTH2-125	N/A	D = 12"	D = 10"
CTH2-150	N/A	N/A	D = 12"

Outside Combustion Air Supply

The Vantage II heater is approved for installation with an outside air supply system. Some compounds such as halogenated hydrocarbons or other corrosive chemicals in the air can be drawn into the equipment and cause an accelerated rate of corrosion of some of the heater components. The use of such chemical compounds near the enclosure should be avoided.

IMPORTANT: If the building has a slight negative pressure or contaminants are present in the air, an outside combustion air supply to the heaters is strongly recommended.

For an outside air supply, a 4" O.D. single wall pipe may be attached to the heater. The duct may be up to 45 ft. maximum length or 2 ft. minimum length with no more than 2 elbows. See *General Requirements* heading on pg. 19 for more detailed guidelines. An outside air supply should not be used with the draft hood venting configuration.

The air supply duct may have to be insulated to prevent condensation on the outer surface. The outside air terminal should be securely fastened to the outside wall by drilling four 1/4" diameter holes in the outside flange; wood screws or bolts and expansion sleeves may be used to fasten the terminal.

FIGURE 17: Non-Pressurized Outside Air Supply Duct

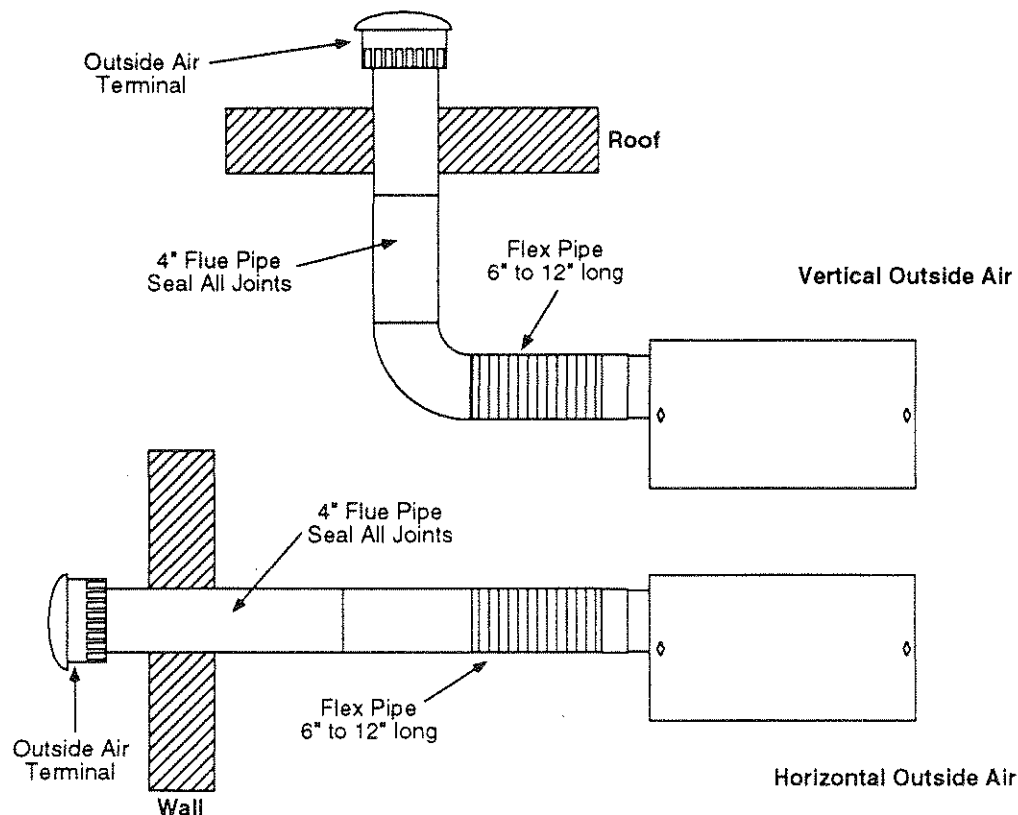

Outside Air Terminal: Use Metalbestos #31267 (RG P/N 90502300),
ACME #104 (RG P/N 90502102), or equivalent.

PVC pipe, "dryer hose", or equivalent may be used instead of standard vent pipe.

GAS PIPING

Section 6

Read applicable warnings in Section 1 before proceeding with Gas Piping installation. Improper installation may result in property damage, severe injury, or death.

Meter and service must be large enough to handle all the burners being installed plus any other connected load. The gas line which feeds the system must be large enough to supply the required gas with a maximum pressure drop of $\frac{1}{2}$ " water column. When gas piping is not included in the layout drawing, the local gas supplier will usually help in planning the gas piping.

A $\frac{1}{2}$ " tapping at each burner location must be located and oriented as shown in Figure 18. To check system pressure, put a plugged $\frac{1}{8}$ " NPT tapping in the gas line at the connection to the burner farthest from the supply. Before connecting the burners to the supply system, verify that all high pressure testing of the gas piping has been completed. **Do not high pressure test the gas piping with the burners connected.**

Follow these instructions to ensure a professional gas supply system installation:

- Support all gas piping with suitable pipe hanging materials.
- Use wrought iron or wrought steel pipe and malleable iron fittings. All pipe and fittings should be new and free from defects. Carefully ream the pipe and tubing ends to remove obstructions and burrs.
- Use L.P. gas-resistant joint compound on all pipe threads.
- Check the pipe and tubing ends for leaks before placing heating equipment into service. When checking for gas leaks, use a soap and water solution; **never use an open flame.**

Install the flex gas connector as shown. The flex gas connector accommodates expansion of the heating system and allows for easy installation and service of the burner.

FIGURE 18: Gas Line Connection with Stainless Steel Flex Gas Connector

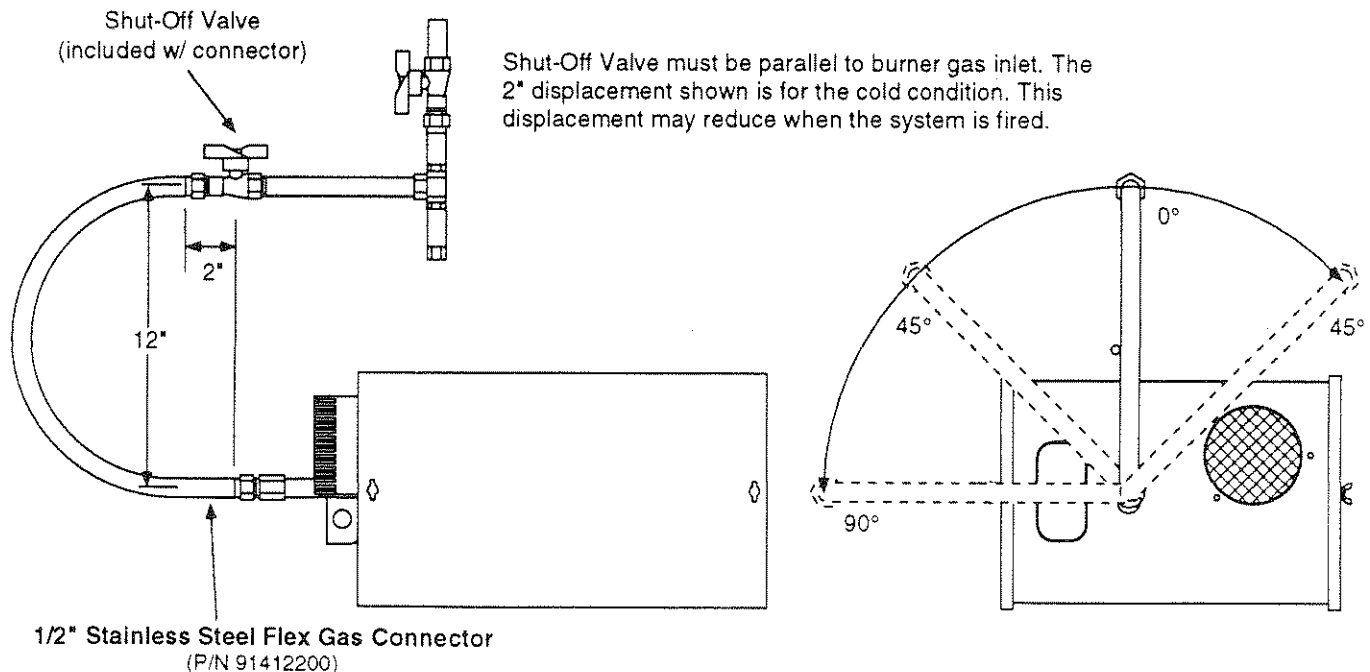

WIRING

Section 7

Heaters are normally controlled by thermostats. Line voltage thermostats are wired directly (see Figure 19); the recommended 24V thermostats use a relay (see Figure 20). Heaters must be grounded in accordance with National Electrical Code ANSI/NFPA 70 - latest revision. Heaters may also be controlled with a manual line voltage switch or timer switch in place of the thermostat.

FIGURE 19: Line Voltage Thermostat Wiring

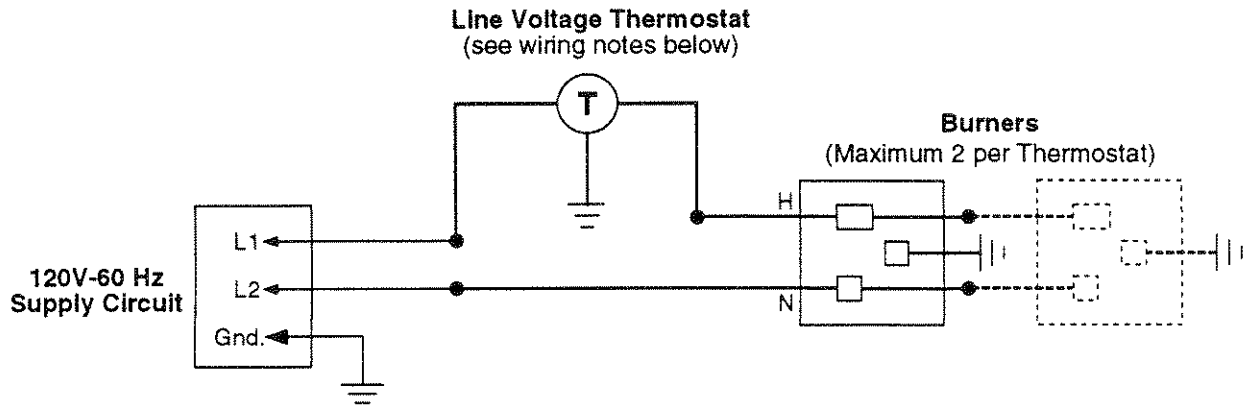

**Line Voltage Thermostat
Moisture Resistant SPDT**
P/N 90437200
(Sunne Controls TF 115)

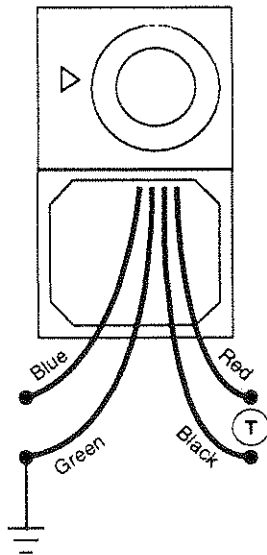

**Line Voltage Thermostat
Heavy Duty - 2 Circuit**
P/N 90411300
(White-Rodgers 176-12)

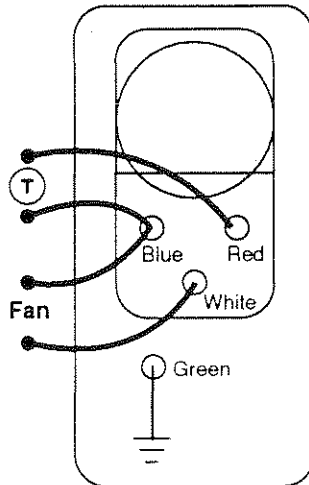

Attach jumper wire between white and red terminals if fan is not utilized.

**Line Voltage Thermostat
Remote Bulb - 2 Circuit**
P/N 90407400
(White-Rodgers 230-15)

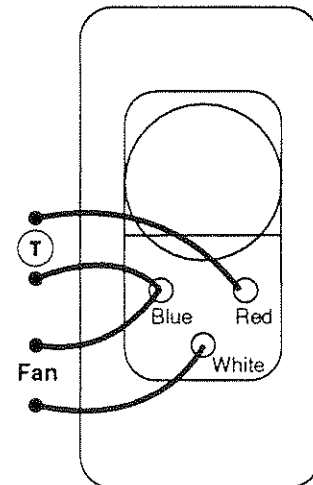

Attach jumper wire between white and red terminals if fan is not utilized.

FIGURE 20: Wiring of Low Voltage Thermostat and Relay

When using 1-2 burners, use SPDT Transformer Relay P/N 90417600
 When using 3-4 burners, use DPDT Transformer Relay P/N 90436300

Wires marked with an asterisk (*) are for use only with the DPDT Transformer Relay

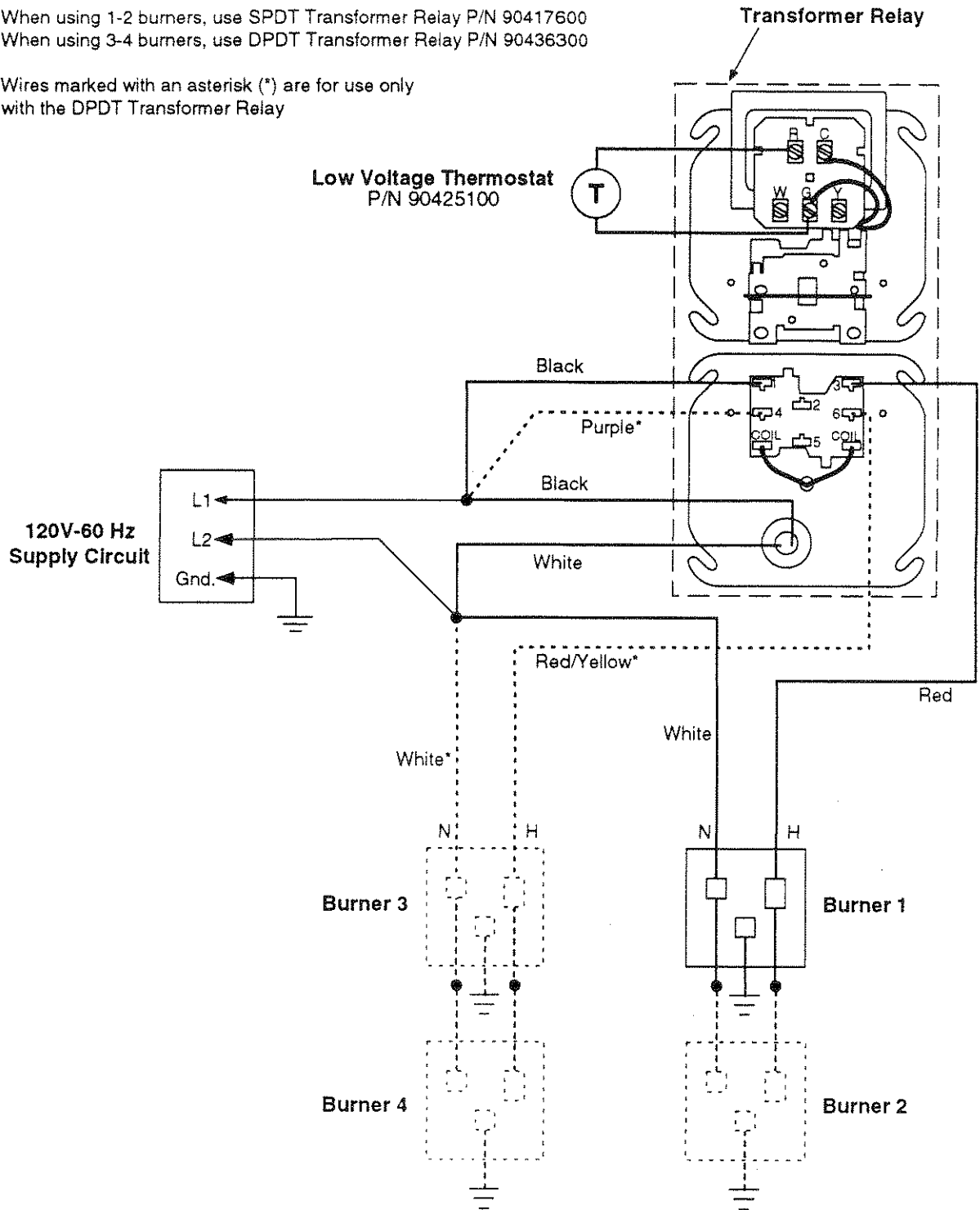
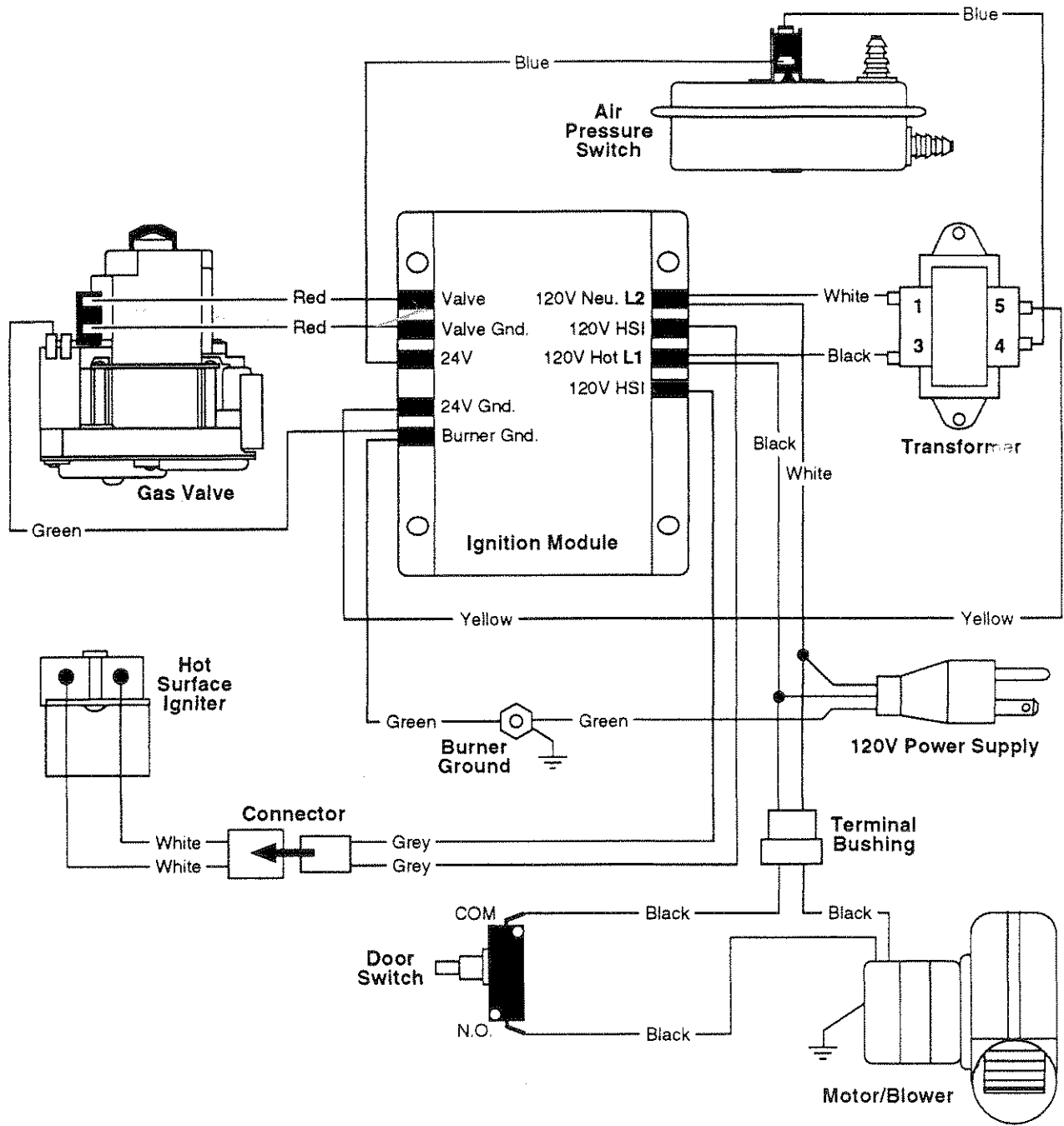
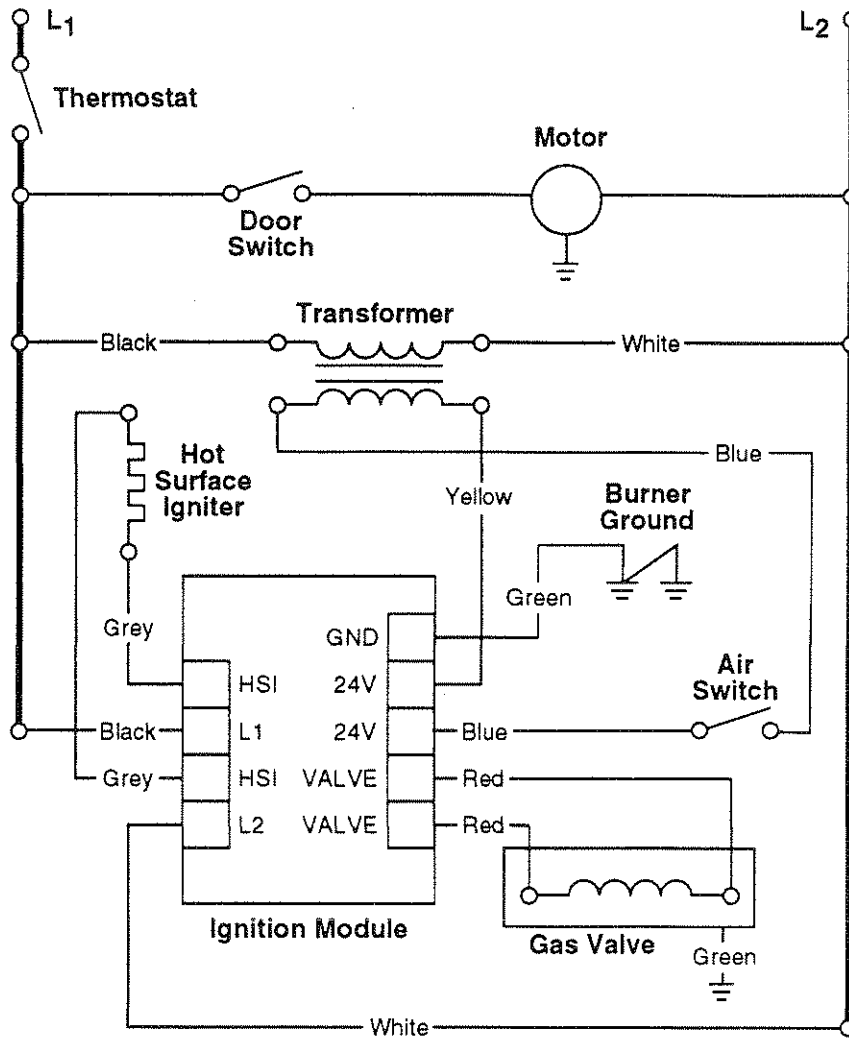

FIGURE 21: Vantage II Burner Internal Wiring



- If any of the original wire as supplied with the appliance must be replaced, it must be replaced with wiring material having a temperature rating of at least 105°C and 600 volts.
- Each burner must be electrically grounded in accordance with National Electrical Code ANSI/NFPA 70 (latest edition).

FIGURE 22: *Vantage II Burner Internal Wiring Ladder Diagram*



OPERATION AND MAINTENANCE**Section 8***Sequence of Operation*

1. Turn the thermostat up. When the thermostat calls for heat, the blower motor will energize.
2. When the motor approaches nominal running RPM, the air proving switch closes and activates the ignition module.
3. The ignition module then energizes the hot surface igniter for a timed warm-up period (approximately 45 to 60 seconds).
4. After the warm-up period, the gas valve is energized.
5. During the last part of the sequence, the igniter is de-energized and is converted to a flame sensing rod.
6. If a flame is detected, the gas valve remains open. When the call for heat is satisfied, and the system control mechanism de-energizes the burner line voltage supply, the gas valves are turned off.
7. If no flame is detected on a single-try module, the gas valve is closed, and the module will lockout until it is reset. Reset is accomplished by removing power from the module for at least 5 seconds (thermostat cycle required).
8. If no flame is detected on a three-trial module, the gas valve is closed, and a purge period begins. After the purge, the module acts to power the igniter for a second warm up period, and a second trial for ignition period. If flame is still not established, a third and final purge, warm up, and trial cycle begins. After three trials, the module will lockout until reset. Reset is accomplished by removing power from the module for at least 5 seconds (thermostat cycle required).
9. On a three-trial module if flame is established, and lost on the first or second trial, the gas valve is turned off, a purge, warm up, and trial for ignition will occur (on a three-trial module, only three trials for ignition are allowed per thermostat cycle).

Maintenance

For best performance, the following maintenance procedures should be performed before each heating season:

1. **Be sure gas and electrical supply to heater are off before performing any service or maintenance.**
2. Check condition of blower scroll and motor. Dirt and dust may be blown out with compressed air, or a vacuum cleaner may be used.
3. Check condition of burner. Carefully remove any dust or debris from inside the burner box or burner cup.
4. Inspect the igniter. Replace igniter if there is excessive carbon residue, erosion, breakage or other defects.
5. Check the inside of the firing tube with a flashlight. If carbon or scale are present, scrape out the deposits with a wire brush or rod, or metal plate attached to a wooden pole.
6. Check to see that the burner observation window is clean and free of cracks or holes. Clean or replace as necessary.
7. Check the flue pipe for soot or dirt. After cleaning as necessary, re-attach the flue pipe to the heater.
8. Outside surfaces of heater reflector may be cleaned by wiping with a damp cloth.
9. A qualified service agency should be contacted for service other than routine maintenance.
10. Check vent terminal and fresh air inlet to see that they have not become blocked during the non-heating season. If either pipe is restricted, the air switch won't close, resulting in a no-heat situation.

Troubleshooting

CAUTION: Before opening the Vantage II burner doors for any type of service, be sure the gas supply has been shut off at the heater, and the electrical cord from the burner box has been unplugged.

- Blower Motor Fails to Run**
1. Is the thermostat calling for heat? Is there 115V at the burner receptacle?
 2. Check blower side door for seal. Check door switch. Replace if necessary.
 3. Check blower for obstructions. Replace blower if necessary.
- Igniter Does Not Glow**
1. Check igniter for damage. Replace if necessary.
 2. Check voltage and resistance at igniter. (Voltage should be 115V. Resistance should be 40-75 Ω).
 3. Check for obstructions to the air inlet and outlet.
 4. Check wiring and hose connections to the air switch. Replace if necessary.
 5. Check voltages at transformer primary and secondary. Replace transformer or module as necessary.
- Valve Does Not Come On**
- Gas pressure downstream of gas control can be measured by using a manometer and connecting to pressure tap on control.
1. Check to see if manual valve to heater is ON.
 2. Check to see if manual valve knob on heater gas control is ON.
 3. Supply gas pressure can be checked at 1/8" NPT pressure tapping on heater external manual valve.
 4. Check to see if gas control is opening: no manifold pressure indicates valve is closed.
- If the valve is closed, either the gas valve or the ignition module is faulty.
- WARNING:** Do not disconnect ground leads inside heater. Do not interchange grounded and ungrounded leads on transformer or ignition module.
- Burner Does Not Light**
1. Check to see if gas lines were properly purged of air.
 2. Check inlet and outlet gas pressure during ignition period.
 - Natural inlet pressure should be 4.6".
 - Natural outlet pressure should be 3.5".
 - LP inlet pressure should be 11.0".
 - LP outlet pressure should be 10.5".
 3. Check for proper orifice and air plate.
- Burner Does Not Stay Lit**
1. Check ground wire continuity.
 2. Check burner internal wiring for reversed leads.
 3. Check insulation on the igniter leads.
 4. Replace module if necessary.

Troubleshooting Guide: VANTAGE II

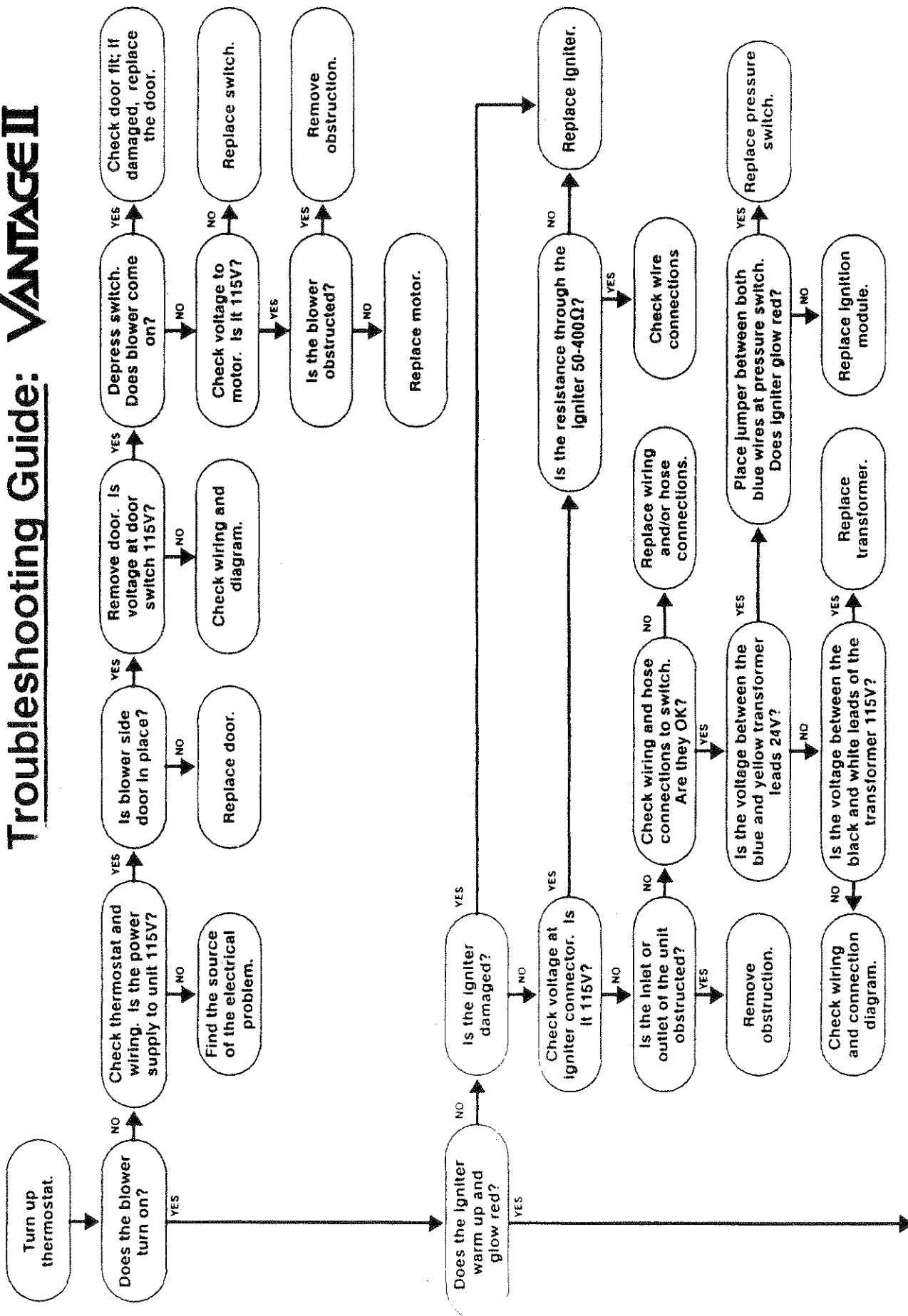
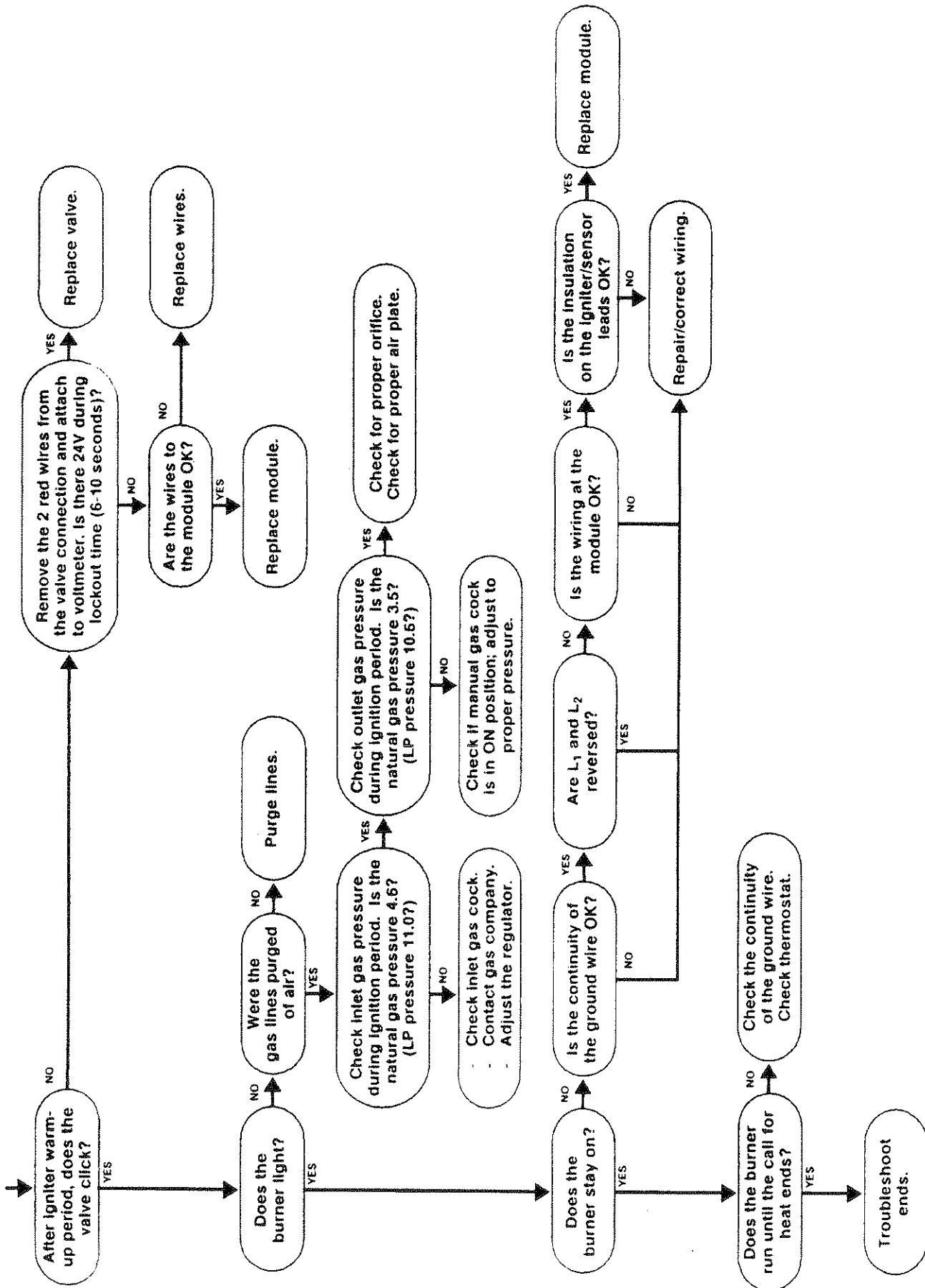

FIGURE 23: Vantage II Troubleshooting Flow Chart



APPENDIX I: Replacement Parts**Section 9**TABLE 3: *Vantage II Replacement Parts* (see Figure 24)

Item	Part Number	Description
1	90436600	Hot Surface Igniter
2	90436900	Transformer
3	90436702	Air Sensing Switch (CTH2-40)
	90436700	Air Sensing Switch (CTH2-60, -80, -100, -125)
	90436701	Air Sensing Switch (CTH2-150)
4	90436500	Hot Surface Ignition Module
5	90436800	Door Switch
6	90708600	Motor and Blower Assembly
7	03050900	Blower Inlet Gasket
8	91911700	Air Adapter Collar
9	03020100	Burner Cup Assembly
10	03090000	Manifold
11	90032500	Gas Valve - Natural
	90032502	Gas Valve - LP
12	02553203	Mica Window Assembly
13	02568200	Tube Gasket

FIGURE 24: *Vantage II Burner and Control Housing* (see Table 3)

TOP VIEW

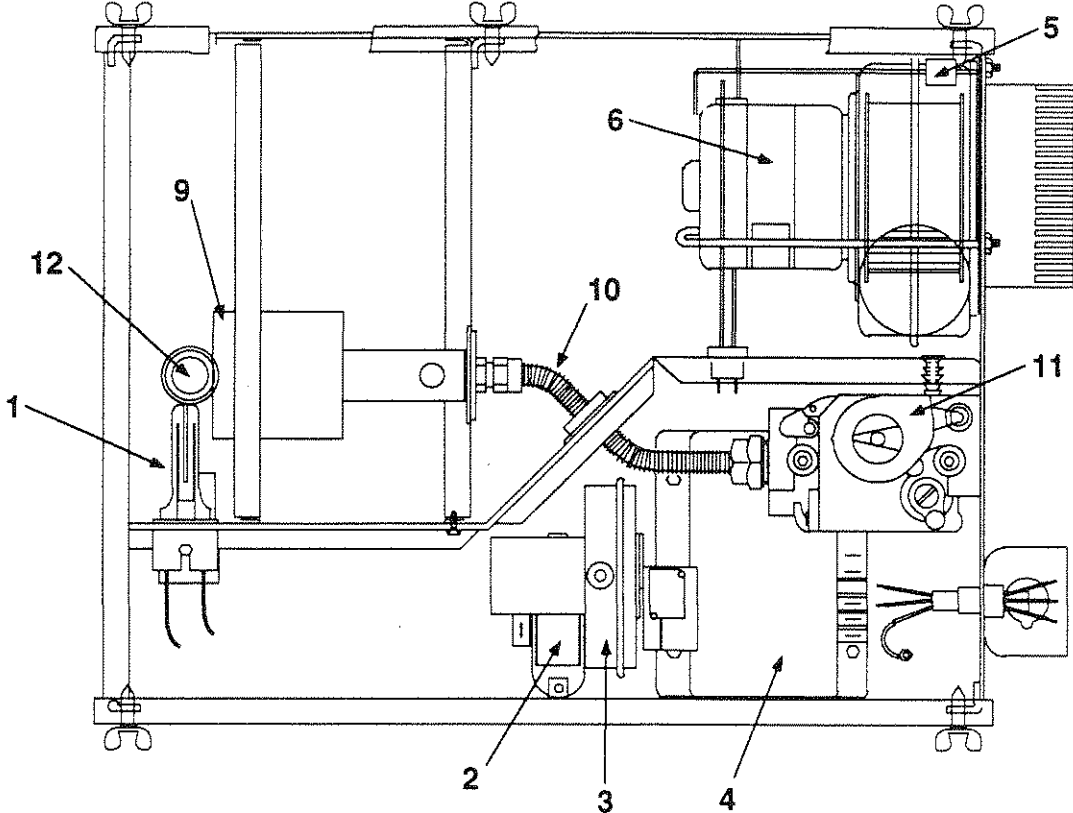

SIDE VIEW

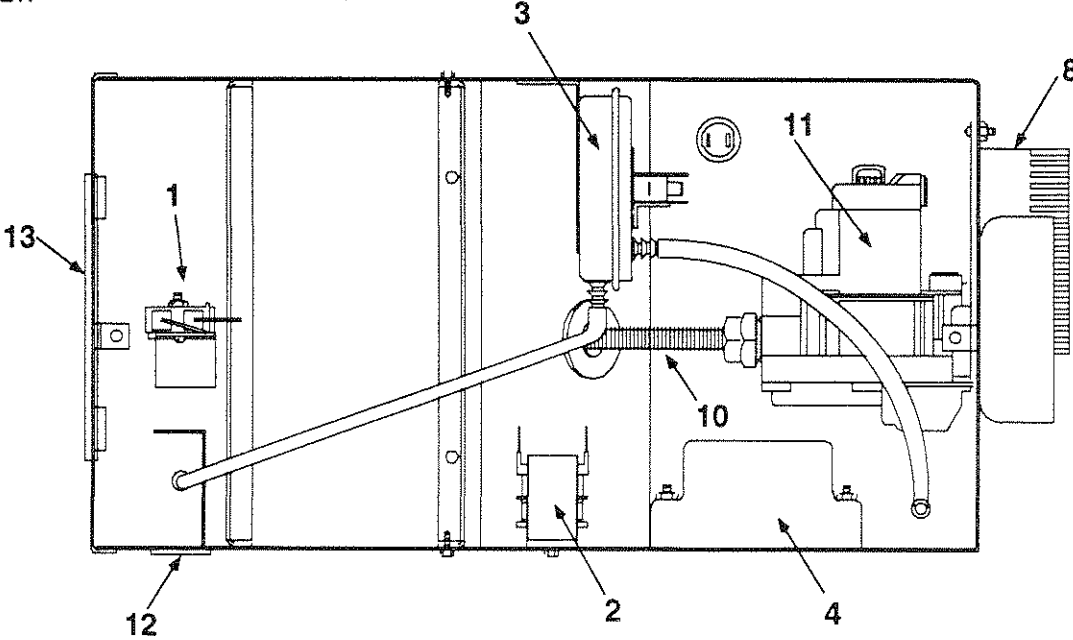

APPENDIX II: Engineering Specifications**Section 9**

The total heating system supplied shall be design certified by the American Gas Association.

A. Burner and Burner Controls

1. Burners shall be capable of firing with one of the fuel options as specified on the purchase documents: Natural Gas or LP.
2. Burners shall be supplied to fire at any one of the input firing rates as specified:

CTH2-40	40,000 BTU/Hr.	CTH2-100	100,000 BTU/Hr.
CTH2-60	60,000 BTU/Hr.	CTH2-125	125,000 BTU/Hr.
CTH2-80	80,000 BTU/Hr.	CTH2-150	150,000 BTU/Hr.
3. Burner shall be equipped with a direct sense silicon-carbide hot surface ignition control system with 100% shut-off ignition device. Power supplied to each heater shall be 120V, 60 HZ, single phase. Burners shall be rated for 1.0 Amp (run) and 5.0 Amp (start).
4. Burner shall be equipped with thermal overload motor protection, balanced air rotor, combustion air proving safety pressure switch, and viewing window for flame observation.
5. When specified, in contaminated environments, the burner shall be capable of supplying outside air to each burner for the support of combustion.
6. All burners shall be pre-wired with a grounded electrical cord and plug.
7. At customer's choice, burners may be controlled with either an optional line voltage thermostat or by optional low voltage thermostats with an appropriate low voltage transformer relay.
8. Gas supply to the burners shall conform to the following:

	1/2" NPT gas connector size
Natural Gas:	4.6" W.C. MIN, 14.0" W.C. MAX
LP Gas:	11" W.C. MIN, 14.0" W.C. MAX

B. Heat Exchanger

1. Radiant tubing shall be 4" diameter hot-rolled steel supplied in 10 ft. sections. Sections shall be joined stainless steel wrap-around couplings.
2. Reflector to be of aluminum material and designed to direct all radiant output below horizontal centerline of radiant tube.
3. Reflectors shall have end caps to prevent heat loss due to convection.
4. Heaters shall be vented according to manufacturer's recommendations.

APPENDIX III: General Specifications

Section 9

General specifications for Vantage II CTH2-Series heaters are as follows:

Burner Ratings and Heat Exchanger Lengths: (Natural and LP)

Model	Rate (Btu/hr)	Heat Exchanger Length		Turbulator
		Minimum (as supplied)	with 10 ft. Extension	
CTH2-40	40,000	10 ft.	N/A	7 ft.
CTH2-60	60,000	20 ft.	30 ft.	10 ft.
CTH2-80	80,000	20 ft.	30 ft.	10 ft.
CTH2-100	100,000	20 ft.	30 ft.	5 ft.
CTH2-125	125,000	30 ft.	40 ft.	none
CTH2-150	150,000	40 ft.	50 ft.	none

Gas Pressure at Manifold:

Natural Gas: 3.5" W.C.
 LP Gas: 10.5" W.C.
 1/2" NPT Gas Connector Size

Gas Inlet Pressure:

Natural Gas: 4.6" W.C. Minimum 11.0" Maximum
 LP Gas: 11.0" W.C. Minimum 14.0" Maximum

Dimensions:

Flue Connection Size: 4"
 Outside Air Connection Size: 4"
 Refer to figure below for dimensional information.

Electrical Rating: (All Models)

120V- 60 Hz., 1.0 Amp (run), 5.0 Amp (start)

FIGURE 25: Vantage II Dimensions and Suggested Mounting Heights

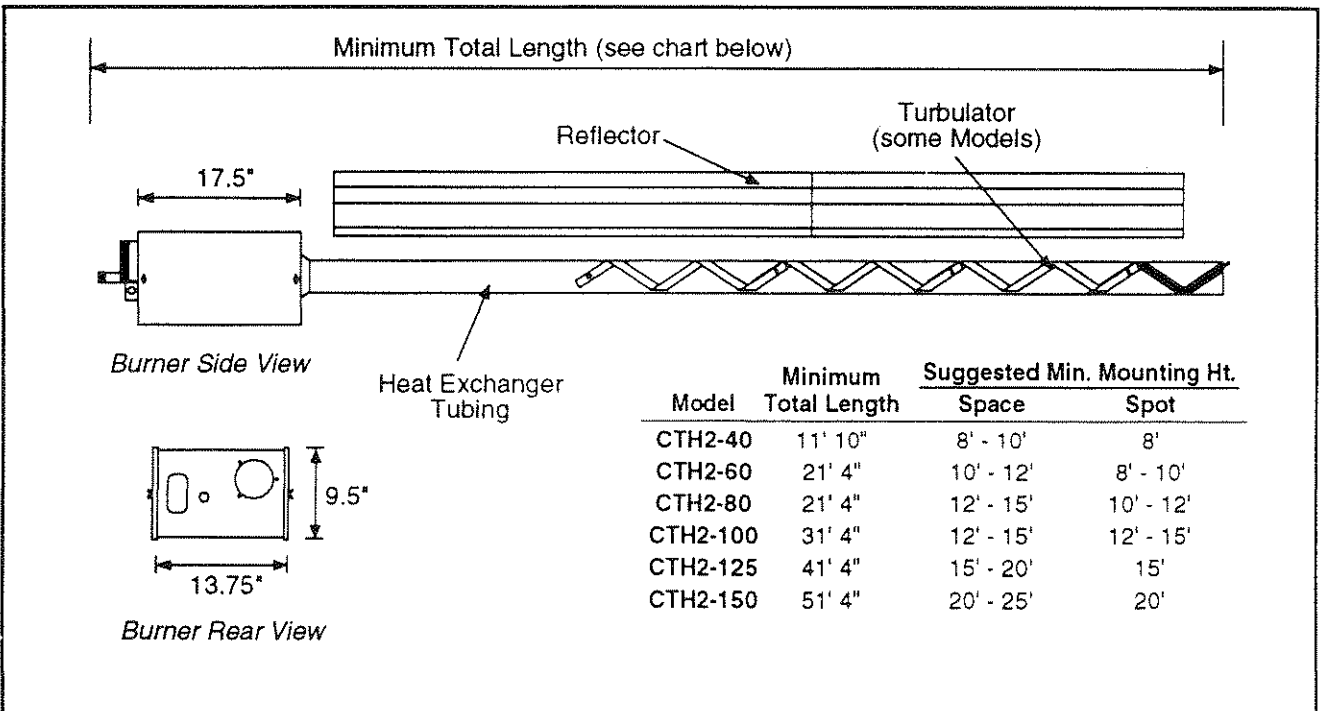

VANTAGE II LIMITED WARRANTY

Warranty Coverage:

ROBERTS-GORDON, INC. ("Seller") warrants that entire heating systems sold by it (individually a "System") and any replacement parts which it sells relating to any System ("Parts") shall be free from defects in workmanship and material for the time periods described as follows. With respect to a System this warranty shall apply for a period of three years from delivery to the original purchaser ("Buyer"). With respect to Parts, this warranty shall apply for the longer of the original System warranty period or for a period of one year. ("Systems" and "Parts" are hereinafter collectively referred to as "Products".) This warranty extends only to the original purchaser of Products.

Seller manufactures products which are designed only to provide predetermined ranges of heat rises in various enclosures when properly used in systems designed by purchaser or others and installed by others. Seller makes no representation or warranty with respect to the effect upon enclosure, or upon any of the contents of the enclosure, including, without limitation, all plant or animal life, kept or processed in the enclosure subject to the limitations outlined below.

Warning:

THIS WARRANTY IS VOID IF THE PRODUCTS HAVE BEEN DAMAGED DUE TO ACCIDENT, ABUSE, MISHANDLING OR ANY OTHER CAUSE WHATSOEVER OTHER THAN DEFECTS IN MATERIAL OR WORKMANSHIP. Specifically, Seller's warranty shall not apply: (a) to damage to Products when used in an atmosphere containing halogenated hydrocarbons or other corrosive chemicals. Some compounds in the air can be ingested into the equipment and can cause an accelerated rate of corrosion of some of the Products. The use of such chemical compounds in or near the enclosure should be avoided where a longer life of the burner, tubing and other parts is desirable; (b) to Products which have been repaired or replaced with other than factory parts, modified in any way, misused or damaged, or which have been installed or used contrary to Seller's written instructions or manuals; or (c) to any damage resulting from improper service or a lack of proper maintenance.

Limitations of Warranty:

OTHER THAN AS STATED HEREIN OR IN ANY OTHER WARRANTY OF SELLER, THERE ARE NO OTHER WARRANTIES OF ANY KIND WHATSOEVER, EXPRESS OR IMPLIED, AND ALL OTHER EXPRESS AND ALL IMPLIED WARRANTIES OF MERCHANTABILITY AND/OR FITNESS FOR ANY PARTICULAR PURPOSE ARE HEREBY SPECIFICALLY DISCLAIMED.

Exclusive Remedy:

THE SOLE AND EXCLUSIVE REMEDY FOR ANY LOSS, DAMAGE OR LIABILITY, OR OTHERWISE, IS LIMITED TO THE OBLIGATION OF SELLER TO REPAIR OR REPLACE PARTS, AT ITS FACTORY, OF ANY PRODUCT OWNED BY ORIGINAL BUYER AND RETURNED TO THE SELLER'S FACTORY WITHIN ONE YEAR AFTER INVOICE, WITH TRANSPORTATION CHARGES PREPAID, WHICH EXAMINATION REVEALS TO HAVE BEEN DEFECTIVE. UNDER NO CIRCUMSTANCES SHALL SELLER BE LIABLE FOR ANY LOSS, DAMAGE, COST, EXPENSES, OR INCIDENTAL OR CONSEQUENTIAL DAMAGES OF ANY KIND, IN CONNECTION WITH THE SALE, INSTALLATION, USE, MAINTENANCE, OR REPAIR OF ANY PRODUCT.

Buyer Responsible for Data:

Seller and its representative may furnish Buyer, upon Buyer's request, data relating to the function and use of Products. Seller shall not be liable for loss, damage, cost, expenses or incidental or consequential damages of any kind, sustained directly or indirectly, by any person, or to any property, if Buyer adopts and uses such data in whole or in part.

Limitations on Authority of Representatives:

No representative of Seller, other than an Executive Officer, has authority to change or extend these provisions. Changes or extension shall be binding only if confirmed in writing by Seller's duly authorized Executive Officer.

Direct any question or warranty claims to the original installer:

Company: _____

Address: _____

Phone: _____

Or to: Warranty Claims, Roberts-Gordon, Inc.,
P.O. Box 44,
Buffalo, NY 14240-0044

