

Vantage® II

Installation, Operation & Service Manual

CTH2-40 CTH2-100
CTH2-60 CTH2-125
CTH2-80 CTH2-150
CTH2-175

FOR YOUR SAFETY

If you smell gas:

1. Open windows.
2. DO NOT try to light any appliance.
3. DO NOT use electrical switches.
4. DO NOT use any telephone in your building.
5. Leave the building.
6. Immediately call your local gas supplier after leaving the building. Follow the gas supplier's instructions.
7. If you cannot reach your gas supplier, call the Fire Department.

Installer

Please take the time to read and understand these instructions prior to any installation. Installer must give a copy of this manual to the owner.

Owner

Keep this manual in a safe place to provide your serviceman with information should it become necessary.



Quality in Any Language™

► Table of Contents

1 Warnings	1	8 Venting and Ducting	23
Read this section carefully. Improper installation, adjustment, operation or maintenance will result in death, injury or property damage.		General Venting Requirements	23
2 Introduction	2	Vent Length Requirements	23
Checking Shipment	2	Unvented Operation	24
Installer Responsibility	2	Horizontal Venting	24
3 Planning	2	Common Side Wall Venting	25
National Standards and Applicable Codes		Vertical Venting	26
Gas Codes	2	Common Vertical Venting	27
Aircraft Hangars	2	Outside Combustion Air Supply	28
Public Garages	2	9 Gas Piping	30
Electrical	3	10 Wiring	31
Venting	3	Line Voltage Thermostat Wiring	31
Hazardous Locations	3	Low Voltage Thermostat and Relay Wiring	32
Critical Considerations	4	Low Voltage Thermostat on One Burner	32
Installation Procedure	4	Burner Internal Wiring	33
4 Clearances to Combustibles	5	Burner Ladder Diagram	33
5 Standard Parts List	8	11 Operation	34
6 Assembly Overview	10	Sequence of Operation	34
Overview Key	10	Maintenance	34
10 ft. Layout	11	12 Troubleshooting	35
20 ft. Layout	11	Manifold Gas Pressure Setting	36
30 ft. Layout	12	Troubleshooting Flow Chart	38
40 ft. Layout	13	13 Replacement Parts	40
50 ft. Layout	14	14 Engineering Specifications	41
60 ft. Layout	15	15 General Specifications	42
70 ft. Layout	16	16 Limited Warranty	43
7 Component Installation	17		
Coupling	17		
Tube Clamp Package	17		
Reflector Support Package	17		
Elbow Fitting Dimensions	18		
Reflector Joint Piece	18		
Reflector End Cap	18		
Typical Suspension Details	19		
Turbulator Baffle Assembly Detail	19		
Side Extension Reflector	20		
U-Tube Package Assembly	21		
Decorative Grille	22		

©1998 **ROBERTS GORDON**

All rights reserved. No part of this work covered by the copyrights herein may be reproduced or copied in any form or by any means—graphic, electronic, or mechanical, including photocopying, recording, taping, or information storage and retrieval systems—without written permission of Roberts-Gordon, Inc.

► Section 1. Warnings

▲ WARNING

FIRE OR EXPLOSION HAZARD

Failure to follow these instructions will result in personal injury or property damage:

1. Read this manual carefully before installing or servicing this equipment. Improper installation, service or maintenance will result in death, injury or property damage.
2. Check clearances given on the outside of each burner to make sure the product is suitable for your application.
3. Installer must be a trained, experienced service technician or representative.
4. All service must be performed only by a trained service technician or representative.
5. After installation is complete, check product operation as provided in these instructions.

Combustibles: Failure to maintain the specified minimum clearances to combustibles could result in a serious fire hazard. Do not locate flammable or combustible materials within this distance. Signs should be posted in storage areas to specify maximum stacking height to maintain required clearances to combustibles. Do not locate in hazardous atmospheres containing flammable vapors or combustible dust. **United States:** Installations in public garages or airplane hangars are permitted when in accordance with ANSI Z83.6 and NFPA-409 and 88 Codes. **Canada:** Installation in public garages is permitted when in accordance with CAN/CGA B.149.2. Installation in airplane hangars is permitted when in accordance with the requirements of the enforcing agency.

Vehicles: Minimum clearances must be maintained from vehicles parked below the heater. Ensure that adequate clearance is maintained where vehicle lifts are in operation.

Gas Connection: There is an expansion of the radiant pipe with each firing cycle, and this will cause the burner to move with respect to the gas line. This can cause a gas leak resulting in an unsafe condition if the gas connection is not made strictly in accordance with Figure 27 of these instructions.

Ignition: This appliance does not have a pilot. It is equipped with an ignition device which automatically lights the burner. Do not try to light the burner by hand.

Mechanical Hazard—Suspension: Use appropriate suspension hardware, beam clamps (rod or perforated strap) and turnbuckles at predetermined locations. The weight and normal movement of the heating system may cause support failure if the following minimum suspension requirements are not met: distance between supports must be 10 ft. (3 m) or less; chain must be general purpose proof coil steel chain, 3/16" or larger in Diameter, with a working load limit of a minimum of 750 lbs. Failure of the supports will cause death, injury or property damage.

▲ WARNING

Failure to follow these instructions will result in personal injury or property damage:

Do not use in an atmosphere containing halogenated hydrocarbons or other corrosive chemicals. Some compounds in the air can be drawn into the equipment and can cause an accelerated rate of corrosion of some parts of the heat exchanger. The use of such chemical compounds in or near the enclosure should be avoided where a longer life of the burner, tubing and other parts is desirable.

Caution should be used when running the system near combustible materials such as wood, paper, rubber, etc. Consideration should be given to partitions, storage racks, hoists, building construction, etc. Figure 1 gives minimum acceptable clearances to combustibles.

If the building has a slight negative pressure or contaminants are present in the air, an outside combustion air supply to the heater is strongly recommended.

▲ CAUTION

Failure to follow these instructions will result in damage to the system components:

Do not high pressure test the gas piping with the burners connected. Failure to follow this procedure will exceed the pressure rating of burner gas controls and this will require complete replacement of these parts.

This heater is designed for heating nonresidential indoor spaces. These instructions, the layout drawing, local codes and ordinances, and applicable standards that apply to gas piping, electrical wiring, venting, etc., must be thoroughly understood before proceeding with the installation.

▲ WARNING

Improper installation, adjustment, alteration, service or maintenance will result in death, injury or property damage. Read the installation, operation and service manual thoroughly before installing or servicing this equipment. For assistance or additional information, consult a qualified installer, service agency or your gas supplier.

FOR YOUR SAFETY:

Do not store or use gasoline or other flammable objects, liquids or vapors in the vicinity of this heater or any other appliance.

► Section 2. Introduction

Roberts-Gordon pioneered low-intensity infrared heating systems in 1962 with the introduction of its revolutionary custom-engineered CORAYVAC® system. In 1973, Roberts-Gordon expanded its product offering to include unitary heating systems. The VANTAGE® II product line was first introduced to North America in 1987 and since its inception, the product has been setting the standard in unitary infrared heating.

The VANTAGE® II (CTH2) is a low-cost, non-condensing, field assembled unitary heating system that is easy to install and requires minimal maintenance. It is designed to provide years of economical operation and trouble-free service.

Checking Shipment

Check the shipment against the Bill of Lading for shortages. Also, check for external damage to cartons. Note any shortages, and/or external damage to cartons on the Bill of Lading in the presence of the carrier. The carrier should acknowledge any shortages or damage by initialing this "noted" Bill of Lading. Immediately report any claims for damaged material, or shortages that were not evident at the time of shipment, to the carrier and your Roberts-Gordon Factory Representative.

Installer Responsibility

All heaters and associated gas piping should be installed in accordance with applicable specifications and this installation made only by firms (or individuals) well qualified in this type of work. Consult local Building Inspectors, Fire Marshals or your local Roberts-Gordon Representative for guidance.

VANTAGE® II heaters are installed on the basis of information given in a layout drawing, which together with the cited codes and regulations, comprise the basic information needed to complete the installation. The installer must furnish all needed material that is not furnished as standard equipment. It is his responsibility to see that such materials, as well as the installation methods he uses, result in a job that is workmanlike and in compliance with all applicable codes.

Roberts-Gordon Factory Representatives have had training and experience in the application of this equipment and can be called on for suggestions about installation which can save material and money.

► Section 3. Planning

The following codes and instructions should be followed when planning the installation of the heater. In addition to these instructions, the warnings in Section 1 must be carefully adhered to since improper installation will result in death, injury or property damage.

National Standards and Applicable Codes

Gas Codes

The type of gas appearing on the nameplate must be the type of gas used. Installation must comply with local codes and recommendations of the local gas company.

United States: Refer to National Fuel Gas Code, ANSI Z223.1 - latest revision, (same as NFPA Bulletin 54).

Canada: Refer to CAN/CGA B149.1 and B149.2: Installation Codes for Gas Burning Appliances.

- Clearance between the heater/ vent and adjacent combustible material (which is part of the building or its contents) shall be maintained to conform with the above listed codes.

Aircraft Hangars

Installation in aircraft hangars must be in accordance with the following codes: **United States:** Refer to Standard for Aircraft Hangars, ANSI/NFPA-409 - latest revision.

Canada: Refer to Standard CAN/CGA B149.1 and B149.2.

- Heaters in aircraft storage or service areas shall be installed a minimum of 10 ft. above the upper surface of wings or engine enclosures of the highest aircraft which may be housed in the hangar. (This is measured from the bottom of the heater to the wing or engine enclosure, whichever is highest from the floor).
- In other sections of aircraft hangars, such as shops or offices, heaters must not be installed less than eight feet above the floor.
- Heaters installed in aircraft hangars shall be located so as not to be subject to damage by aircraft, cranes, movable scaffolding or other objects.

Public Garages

Installation in garages must be in accordance with the following codes: **United States:** Standard for Parking Structures NFPA-88A - latest revision or the Standard for Repair Garages, NFPA 88B - latest revision. **Canada:** Refer to CAN/CGA B149.1 and B149.2: Installation Codes for Gas Burning Appliances.

- Heaters must not be installed less than eight feet above the floor. Minimum clearances to combustibles must be maintained from vehicles parked below the heater.
- When installed over hoists, minimum clearances to combustibles must be maintained from the uppermost point on the hoist.

Electrical

⚠ WARNING	
	<p>Electrical Shock Hazard</p> <p>Heater must be installed and grounded according to national codes.</p> <p>Failure to follow these instructions will result in death or electrical shock.</p>

The heater must be electrically grounded in accordance with the following codes: **United States:** Refer to National Electrical Code, ANSI/NFPA-70 - latest revision. Wiring must conform to the most current National Electrical Code, local ordinances, and any special diagrams furnished. **Canada:** Refer to Canadian Electrical Code, CSA C22.1 Part 1 - latest revision.

Venting



⚠ WARNING	
	<p>Carbon Monoxide Hazard</p> <p>Unvented heaters must be interlocked with sufficient building exhaust.</p> <p>Vented heaters must be vented outdoors.</p> <p>Unvented and vented heaters must be installed according to the installation manual.</p> <p>Failure to follow these instructions will result in death or injury.</p>

The venting must be installed in accordance with the following codes: **United States:** Refer to NFPA-54/ANSI-Z223.1 - latest revision, National Fuel Gas Code. **Canada:** Refer to CAN/CGA B149.1 and B149.2: Installation Codes for Gas Burning Appliances.

Partial information with regard to these codes is provided in Section 8 of this installation manual with regard to size and configurations for venting arrangements.

Any portion of vent pipe passing through a combustible wall must be dual insulated and have an approved thimble to conform with above listed codes.

Hazardous Locations

⚠ WARNING	
	
<p>Fire Hazard</p> <p>Some objects will catch fire or explode when placed close to heater.</p> <p>Keep all flammable objects, liquids and vapors the required safe distances away from heater.</p> <p>Failure to follow these instructions will result in death, injury or property damage.</p>	<p>Burn Hazard</p> <p>Keep all persons, especially children, away from heater.</p> <p>Do not touch any part of the heater.</p> <p>Heater is very hot.</p> <p>Failure to follow these instructions will result in severe injury.</p>
⚠ ATTENTION	
<p>Risque d'incendie</p> <p>Certains objets placés près du radiateur peuvent s'enflammer ou exploser.</p> <p>Tenir tous les objets, liquides et vapeurs inflammables à la distance de sécurité requise du radiateur.</p> <p>Le non-respect de ces consignes peut causer mort, blessures ou dommage matériel.</p>	<p>Risque de brûlure</p> <p>Ne laisser personne, en particulier des enfants, s'approcher du radiateur.</p> <p>Ne toucher aucune partie du radiateur.</p> <p>Le radiateur est brûlant.</p> <p>Le non-respect de ces consignes peut entraîner des blessures graves.</p>

Where there is the possibility of exposure to combustible airborne material or vapor, consult the local Fire Marshall, the fire insurance carrier or other authorities for approval of the proposed installation.

Critical Considerations

⚠ WARNING

Fire Hazard
<p>Some objects will catch fire or explode when placed close to heater.</p> <p>Keep all flammable objects, liquids and vapors the required safe distances away from heater.</p> <p>Failure to follow these instructions will result in death, injury or property damage.</p>
⚠ ATTENTION
Risque d'incendie
<p>Certains objets placés près du radiateur peuvent s'enflammer ou exploser.</p> <p>Tenir tous les objets, liquides et vapeurs inflammables à la distance de sécurité requise du radiateur.</p> <p>Le non-respect de ces consignes peut causer mort, blessures ou dommage matériel.</p>

The VANTAGE® II is a suspended heater. Therefore, its stability, flexibility, and safety are very important. Before starting installation, be sure the system can meet the following requirements:

- Maintain specified clearances to combustibles, and safe distance from heat-sensitive material, equipment and work stations.
- Provide a suspension with vertical length of chain or swinging rod which has at least two inches (5cm) of horizontal travel for each burner in a straight run. Be sure the suspension system is sufficiently flexible to accommodate thermal expansion which occurs as the system heats up (see Figure 15).
- Provide access to burners for servicing, preferably on both sides, above, and behind for burner removal.
- Be sure the heater has a downward pitch of 1/2" per 20' (1 cm per 5 m) away from the burner.
- Provide signs in storage areas to specify maximum stacking height to maintain required clearances to combustibles.
- Plan location of supports. Locate a support near all elbows.
- A minimum of 10 ft. (3 m) on CTH2-60/80 and a minimum of 15 ft. (4.5 m) on CTH2-100/125/150/175 is required between the burner and the first elbow.

Installation Procedure

⚠ WARNING
<p>Several steps are involved in the installation of the heater.</p> <p>Do not attempt to operate the heater until all steps of the installation have been accomplished.</p> <p>Failure to follow these instructions will result in death, injury or property damage.</p>

Take maximum advantage of the building's upper structure, beams, joists, purlins, etc., from which to suspend the heater. There is no unique sequence for installation of the tubing. On-site observation will usually reveal a logical sequence. Begin the installation at the most critical dimension. This could save time. Watch for swinging doors, overhead cranes, car lifts, etc. Reflectors and tubing can be installed as you move along. Carefully adjust system pitch at each position to level the heater. Pitch down 1/2" per 20' (1 cm per 5 m) away from burner.



Do Not:

- Pressure test the gas line using high pressure (greater than 1/2 PSIG) without closing the high-pressure shutoff cocks. Failure to do so will result in damage to the burners.

Do:

- Familiarize yourself with local and national codes.
- Develop a planned procedure which will conserve material and labor on the job.
- Check to see that all material and equipment is on the job before starting installation.
- Allow for thermal expansion of the hot tube.
- Install the gas connector only as shown in instructions. (See Figure 27)
- Have slip joints where required between reflectors to keep them from buckling or coming apart.
- Provide one square inch of free air opening to each 1,000 BTU/hr of heater input but not less than 100 square inches in enclosed spaces. (6.5 cm² per 250 kcal/hr). One opening should be within 12 inches (30 cm) of the top and one within 12 inches (30 cm) of the bottom of the enclosure.

► Section 4. Clearances to Combustibles

⚠ WARNING	
	
Fire Hazard	Burn Hazard
<p>Some objects will catch fire or explode when placed close to heater.</p> <p>Keep all flammable objects, liquids and vapors the required safe distances away from heater.</p> <p>Failure to follow these instructions will result in death, injury or property damage.</p>	<p>Keep all persons, especially children, away from heater.</p> <p>Do not touch any part of the heater.</p> <p>Heater is very hot.</p> <p>Failure to follow these instructions will result in severe injury.</p>
⚠ ATTENTION	
Risque d'incendie	Risque de brûlure
<p>Certains objets placés près du radiateur peuvent s'enflammer ou exploser.</p> <p>Tenir tous les objets, liquides et vapeurs inflammables à la distance de sécurité requise du radiateur.</p> <p>Le non-respect de ces consignes peut causer mort, blessures ou dommage matériel.</p>	<p>Ne laisser personne, en particulier des enfants, s'approcher du radiateur.</p> <p>Ne toucher aucune partie du radiateur.</p> <p>Le radiateur est brûlant.</p> <p>Le non-respect de ces consignes peut entraîner des blessures graves.</p>

In all situations, clearances to combustibles must be maintained. Failure to observe clearances to combustibles will result in death, severe injury or property damage. Signs should be posted in storage areas to specify the maximum stacking height to maintain required clearances to combustibles. Minimum clearances must be maintained from vehicles parked below the heater. Caution should be used when running the system near combustible materials such as wood, paper, rubber, etc. Consideration should be given to partitions, storage racks, hoists, building construction, etc. Figure 1a-1i gives minimum acceptable clearances to combustibles.

NOTE: 1. All dimensions are in inches - except as noted.
 2. All dimensions are from the tube surface.
 3. Clearances B, C and D can be reduced by 50% for locations 25 ft. or more downstream of the burner.

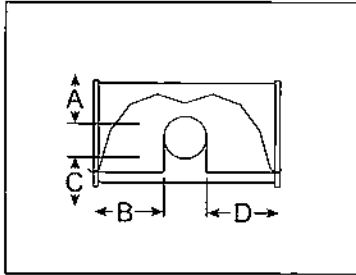

Figure 1a. Standard Reflector

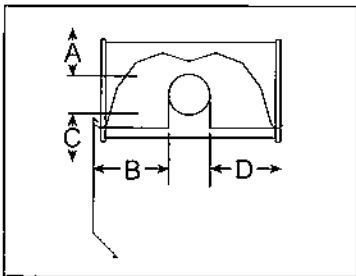

Figure 1b. One Side Reflector

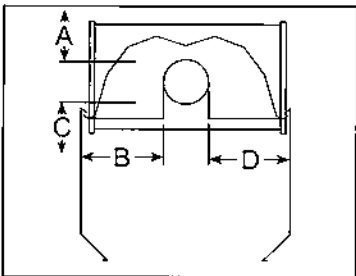

Figure 1c. 2 Side Reflectors

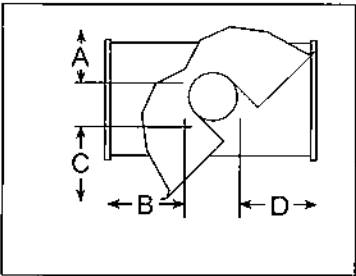

Figure 1d. 45° Tilt Reflector

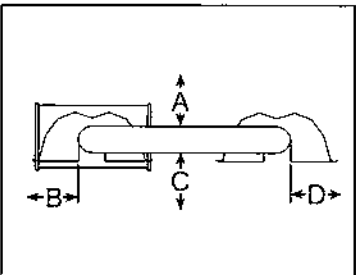

Figure 1e. U-Tube, Standard

United States				
Model	A	B	C	D
CTH2-40	6	27	53	27
CTH2-60	6	35	63	35
CTH2-80	6	38	66	38
CTH2-100	6	40	71	40
CTH2-125	6	46	77	46
CTH2-150	6	50	80	50
CTH2-175	8	52	82	52

Model	A	B	C	D
CTH2-40	6	9	53	44
CTH2-60	6	9	63	47
CTH2-80	6	9	70	54
CTH2-100	6	9	77	59
CTH2-125	6	9	83	65
CTH2-150	6	9	86	69
CTH2-175	8	9	88	73

Model	A	B	C	D
CTH2-40	6	15	53	15
CTH2-60	6	23	66	23
CTH2-80	6	25	72	25
CTH2-100	6	27	78	27
CTH2-125	6	32	84	32
CTH2-150	6	35	88	35
CTH2-175	8	40	91	40

Model	A	B	C	D
CTH2-40	8	8	51	46
CTH2-60	8	8	60	54
CTH2-80	8	8	66	60
CTH2-100	10	8	74	64
CTH2-125	10	8	78	69
CTH2-150	12	8	84	74
CTH2-175	12	8	85	79

Model	A	B	C	D
CTH2-40	-	-	-	-
CTH2-60	6	35	63	30
CTH2-80	6	38	69	37
CTH2-100	6	40	76	39
CTH2-125	6	46	79	43
CTH2-150	6	50	84	47
CTH2-175	8	54	87	51

Canada *				
Model	A	B	C	D
CTH2-40	6	23	50	23
CTH2-60	6	27	53	27
CTH2-80	6	30	59	30
CTH2-100	6	33	64	33
CTH2-125	6	35	66	35
CTH2-150	6	39	71	39
CTH2-175	8	43	75	43

Model	A	B	C	D
CTH2-40	6	9	50	35
CTH2-60	6	9	55	39
CTH2-80	6	9	61	45
CTH2-100	6	9	66	50
CTH2-125	6	9	71	55
CTH2-150	6	9	75	58
CTH2-175	8	9	80	61

Model	A	B	C	D
CTH2-40	6	14	52	14
CTH2-60	6	20	58	20
CTH2-80	6	22	63	22
CTH2-100	6	26	67	26
CTH2-125	6	29	71	29
CTH2-150	6	33	77	33
CTH2-175	8	38	87	38

Model	A	B	C	D
CTH2-40	7	7	42	41
CTH2-60	7	7	47	46
CTH2-80	7	7	53	52
CTH2-100	9	7	60	59
CTH2-125	9	7	64	63
CTH2-150	11	7	67	66
CTH2-175	11	7	70	68

Model	A	B	C	D
CTH2-40	-	-	-	-
CTH2-60	6	29	56	25
CTH2-80	6	33	63	30
CTH2-100	6	36	66	32
CTH2-125	6	40	71	36
CTH2-150	6	42	73	37
CTH2-175	8	47	78	42

Canada - metric (cm)				
Model	A	B	C	D
CTH2-40	15	58	127	58
CTH2-60	15	69	135	69
CTH2-80	15	76	150	76
CTH2-100	15	84	163	84
CTH2-125	15	89	168	89
CTH2-150	15	99	180	99
CTH2-175	20	109	190	109

Model	A	B	C	D
CTH2-40	15	23	127	89
CTH2-60	15	23	135	99
CTH2-80	15	23	155	114
CTH2-100	15	23	168	127
CTH2-125	15	23	180	140
CTH2-150	15	23	191	147
CTH2-175	20	23	203	155

Model	A	B	C	D
CTH2-40	15	36	132	36
CTH2-60	15	51	147	51
CTH2-80	15	56	160	56
CTH2-100	15	66	170	66
CTH2-125	15	74	180	74
CTH2-150	15	84	196	84
CTH2-175	20	96	221	96

Model	A	B	C	D
CTH2-40	18	23	107	104
CTH2-60	18	23	119	117
CTH2-80	18	23	135	132
CTH2-100	23	23	152	150
CTH2-125	23	23	163	160
CTH2-150	28	23	170	168
CTH2-175	28	23	178	173

Model	A	B	C	D
CTH2-40	-	-	-	-
CTH2-60	15	74	142	64
CTH2-80	15	84	160	76
CTH2-100	15	91	168	81
CTH2-125	15	102	180	91
CTH2-150	15	107	185	94
CTH2-175	15	119	198	107

(*) For Brooder Clearances, use United States Clearances

NOTE: 1. All dimensions are in inches-except as noted.
 2. All dimensions are from the tube surface.
 3. Clearances B, C and D can be reduced by 50% for locations 25 ft. or more downstream of the burner.

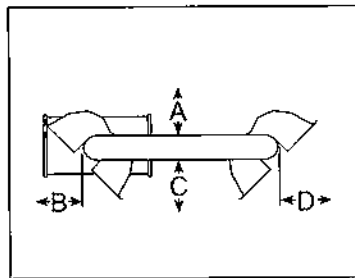

Figure 1f. U-Tube, Opposite 45°

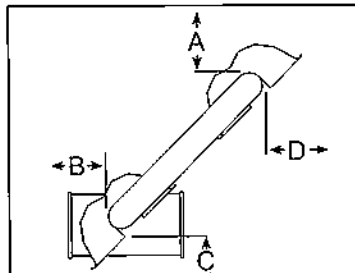

Figure 1g. U-Tube, Full 45°

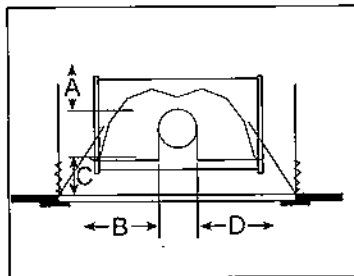

Figure 1h. 2-Foot Deco Grille

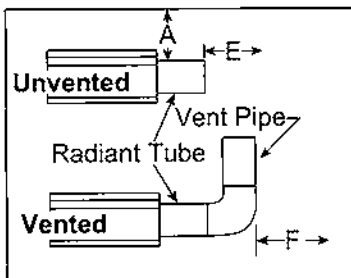

Figure 1i. Venting

United States					Canada*					Canada - metric (cm)				
Model	A	B	C	D	Model	A	B	C	D	Model	A	B	C	D
CTH2-40	-	-	-	-	CTH2-40	-	-	-	-	CTH2-40	-	-	-	-
CTH2-60	8	54	60	22	CTH2-60	7	46	47	17	CTH2-60	18	117	119	43
CTH2-80	8	60	66	22	CTH2-80	7	52	53	17	CTH2-80	18	132	135	43
CTH2-100	10	64	74	22	CTH2-100	9	59	60	17	CTH2-100	23	150	152	43
CTH2-125	10	70	78	22	CTH2-125	9	63	64	17	CTH2-125	23	160	163	43
CTH2-150	12	74	84	22	CTH2-150	11	66	67	17	CTH2-150	28	168	170	43
CTH2-175	12	76	85	22	CTH2-175	11	70	80	17	CTH2-175	28	178	203	43
Model	A	B	C	D	Model	A	B	C	D	Model	A	B	C	D
CTH2-40	-	-	-	-	CTH2-40	-	-	-	-	CTH2-40	-	-	-	-
CTH2-60	8	8	60	42	CTH2-60	7	7	47	36	CTH2-60	18	23	119	91
CTH2-80	8	8	66	46	CTH2-80	7	7	53	44	CTH2-80	18	23	135	112
CTH2-100	8	8	74	52	CTH2-100	7	7	60	49	CTH2-100	18	23	152	124
CTH2-125	8	8	78	61	CTH2-125	7	7	64	55	CTH2-125	18	23	163	140
CTH2-150	8	8	84	66	CTH2-150	7	7	67	58	CTH2-150	18	23	170	147
CTH2-175	8	8	85	70	CTH2-175	7	9	71	63	CTH2-175	18	23	180	160
Model	A	B	C	D	Model	A	B	C	D	Model	A	B	C	D
CTH2-40	6	27	53	27	CTH2-40	6	23	50	23	CTH2-40	15	58	127	58
CTH2-60	6	35	63	35	CTH2-60	6	27	53	27	CTH2-60	15	69	135	69
CTH2-80	6	38	66	38	CTH2-80	6	30	59	30	CTH2-80	15	76	150	76
CTH2-100	6	40	71	40	CTH2-100	6	33	64	33	CTH2-100	15	84	163	84
CTH2-125	6	46	77	46	CTH2-125	6	35	66	35	CTH2-125	15	89	168	89
CTH2-150	6	50	80	50	CTH2-150	6	39	71	39	CTH2-150	15	99	180	99
CTH2-175	8	52	82	52	CTH2-175	8	43	75	43	CTH2-175	20	109	190	109
Model	A	E	F	Model	A	E	F	Model	A	E	F			
CTH2-40	14	18	18	CTH2-40	14	18	18	CTH2-40	36	46	46			
CTH2-60	14	18	18	CTH2-60	14	18	18	CTH2-60	36	46	46			
CTH2-80	20	24	18	CTH2-80	20	24	18	CTH2-80	51	61	46			
CTH2-100	20	24	18	CTH2-100	20	24	18	CTH2-100	51	61	46			
CTH2-125	20	24	18	CTH2-125	20	24	18	CTH2-125	51	61	46			
CTH2-150	20	30	18	CTH2-150	20	30	18	CTH2-150	51	76	46			
CTH2-175	20	30	18	CTH2-175	20	30	18	CTH2-175	51	76	46			

(*) For Brooder Clearances, use United States Clearances

► Section 5. Standard Parts List

The following section provides information about assembling VANTAGE® II heaters. The heaters must be assembled according to the following illustrations and tables in order to ensure safe and proper operation.

VANTAGE® II burner cartons contain the Basic Burner Unit, a Pipe Nipple and Flex Gas Line for gas connection. Turbulators (when required) are listed in Table 2.

The remaining heater components are shipped in one of two ways:

- 1) Typically, tubes, reflectors, hangers, etc. are pre-packaged at the factory. Components for heaters of up to 40 ft. (12 m) length are accommodated in one carton that includes a 10 ft. (3 m) transition tube. Longer heaters require two accessory cartons. One carton will include a transition tube. (A few minor components such as end caps may be duplicated.)

Necessary packages for the various heaters are shown in Table 1 below. Components should be assembled as per Figures 2 through 19.

- 2) In some cases, VANTAGE® II heaters may be received with the accessory components non-cartoned, or packaged for a specific installation. In those cases, be sure to acquaint yourself with the individual components shown in Figure 2. Also follow carefully the appropriate diagram (Figures 3 through 8) for the heater you ordered. These indicate the quantity and location of all necessary components.

Figures 9 through 19 show specific assembly details. Refer to Section 8 for venting assembly, Section 9 for gas piping assembly, and Section 10 for field wiring.

Table 1. VANTAGE® II Component Package Guide

Model	Tubing Length		Required Accessory Packages		For Assembly see page
	Minimum	Optional	Standard	Aluminized	
CTH2-40	10' (3 m)	-	-	CP10ALUM	pg 11
CTH2-60	20' (6 m)	-	CP20HRS	CP20ALUM	pg 11
CTH2-80	20' (6 m)	-	CP20HRS	CP20ALUM	pg 11
		30' (9 m)	CP30HRS	CP30ALUM	pg 12
CTH2-100	30' (9 m)	-	CP30HRS	CP30ALUM	pg 12
		40' (12 m)	CP40HRS	CP40ALUM	pg 13
CTH2-125	40' (12 m)	-	CP40HRS	CP40ALUM	pg 13
		50' (15 m)	CP30HRS + EXP20HRS	CP30ALUM + EXP20ALUM	pg 14
CTH2-150	50' (15 m)	-	CP30HRS + EXP20HRS	CP30ALUM + EXP20ALUM	pg 14
		60' (18 m)	CP30HRS + EXP30HRS	CP30ALUM + EXP30ALUM	pg 15
CTH2-175	50' (15 m)	-	CP30HRS + EXP20HRS	CP30ALUM + EXP20ALUM	pg 14
		60' (18 m)	CP30HRS + EXP30HRS	CP30ALUM + EXP30ALUM	pg 15
		70' (21 m)	CP30HRS + EXP40HRS	CP30ALUM + EXP40ALUM	pg 16

Table 2. Contents of VANTAGE® II Burner Carton

Part No.	Description	CTH2-40		-60	-80	-100	-125	-150	-175
	CTH2 Burner Assembly (rate and fuel varies)	1	1	1	1	1	1	1	1
02568200	Gasket (Burner to Transition Tube)	1	1	1	1	1	1	1	1
130100NA	Installation Manual	1	1	1	1	1	1	1	1
91201708	Pipe Nipple (Black) 1/2 x 3-1/2	1	1	1	1	1	1	1	1
94273914	Hex Head Bolt 5/16 - 18 - Rolok	4	4	4	4	4	4	4	4
96411600	Split Lockwasher	4	4	4	4	4	4	4	4
91412200	Flexible Gas Connector Assembly - 1/2" NPT	1	1	1	1	1	-	-	-
91412203	Flexible Gas Connector Assembly - 3/4" NPT	-	-	-	-	-	1	1	-
03051503	Turbulator Adapter	1	1	1	1	-	-	-	-
03051504	Turbulator 2.5 ft. (76 cm) Section Piece, Aluminized Steel	2	4	4	2	-	-	-	-
03051505	Turbulator 2.5 ft. (76 cm) Section Piece, Stainless Steel	1	-	-	-	-	-	-	-

Table 3. Contents of Accessory Packages

Part No.	Description	Core Packages								Extension Packages							
		Hot Rolled			Aluminized				Hot Rolled				Aluminized				
		20'	30'	40'	10'	20'	30'	40'	10'	20'	30'	40'	10'	20'	30'	40'	
91409300	Tube, Hot Rolled Steel, 10 ft.	1	2	3	-	-	-	-	1	2	3	4	-	-	-	-	
91409408	Tube, HT Aluminized, 10 ft.	-	-	-	-	1	2	3	-	-	-	-	1	2	3	4	
03051100	Transition Tube, Aluminized, 10 ft.	1	1	1	-	1	1	1	-	-	-	-	-	-	-	-	
03051600	Transition Tube, HT Aluminized, 10 ft.	-	-	-	1	-	-	-	-	-	-	-	-	-	-	-	
01312700	Standard Coupling Assembly	1	2	3	-	1	2	3	1	2	3	4	1	2	3	4	
02750303	Standard 8 ft. Reflector	3	4	6	2	3	4	6	2	3	4	6	2	3	4	6	
02750800	End Cap	2	2	2	2	2	2	2	-	-	-	-	-	-	-	-	
03090100	Tube and Reflector Hanger	3	4	5	2	3	4	5	1	2	3	4	1	2	3	4	
91907302	S-Hook	3	4	5	2	3	4	5	1	2	3	4	1	2	3	4	
03050010	Refl. Support Pkg. (Strap, Wire Form, Screws)	2	3	5	1	2	3	5	2	3	4	6	2	3	4	6	
91107720	U-Clip Package	1	1	1	1	1	1	1	1	1	1	1	1	1	1	1	
90502700	Vent Adapter	1	1	1	1	1	1	1	-	-	-	-	-	-	-	-	
01318901	Tube Clamp Package	1	1	1	1	1	1	1	-	-	-	-	-	-	-	-	

Package Part Numbers:	CP20HRS	CP30HRS	CP40HRS	CP10ALUM	CP20ALUM	CP30ALUM	CP40ALUM	EXP10HRS	EXP20HRS	EXP30HRS	EXP40HRS	EXP10ALUM	EXP20ALUM	EXP30ALUM	EXP40ALUM
-----------------------	---------	---------	---------	----------	----------	----------	----------	----------	----------	----------	----------	-----------	-----------	-----------	-----------

► Section 6. Assembly Overview

The figures in this section provide a general overview of component placement in a VANTAGE® II system. The location of some components such as supports and couplings is crucial to proper installation. Assemble the heater components as shown in Figures 3 through 8.

Optional reflector configurations are shown in Figure 1. Install appropriate suspension hardware, beam clamps, chain or rod at predetermined locations. Adjustment of chain length will provide uniform pitch.

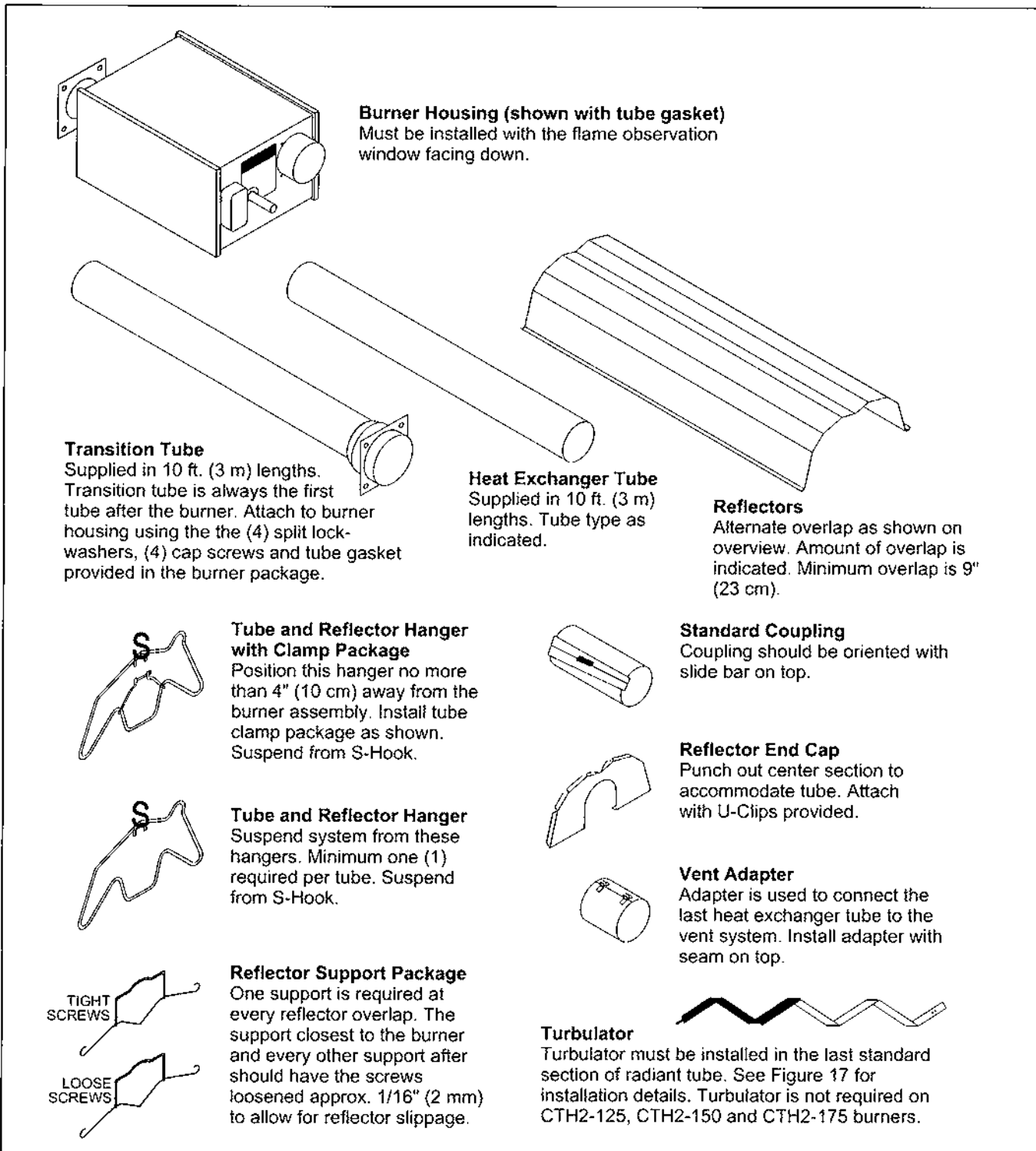

Figure 2. Assembly Overview

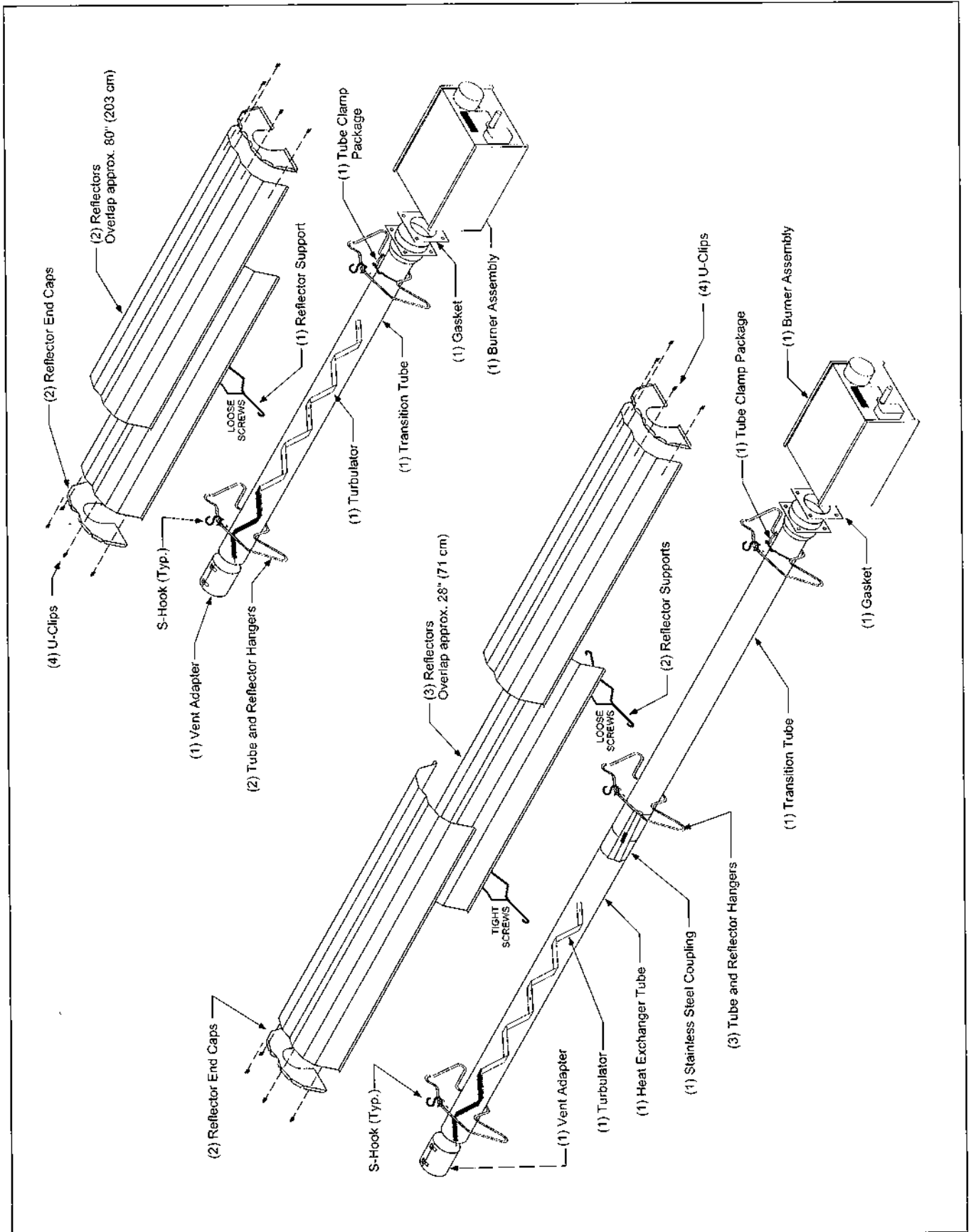

Figure 3. Assembly of 10 ft (3 m) Heat Exchanger System
 Assembly of 20 ft (6 m) Heat Exchanger System

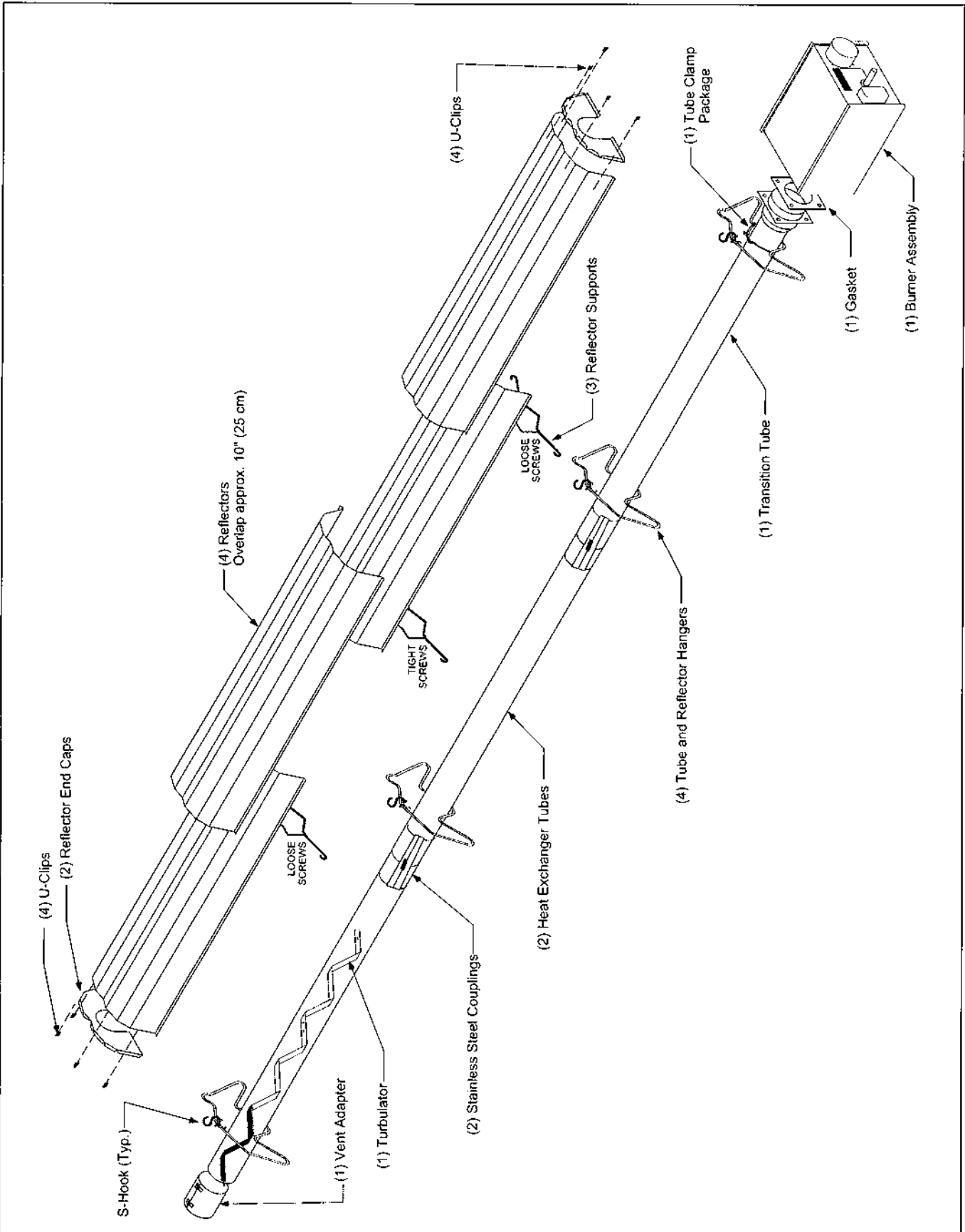

Figure 4. Assembly of 30 ft (9 m) Heat Exchanger System

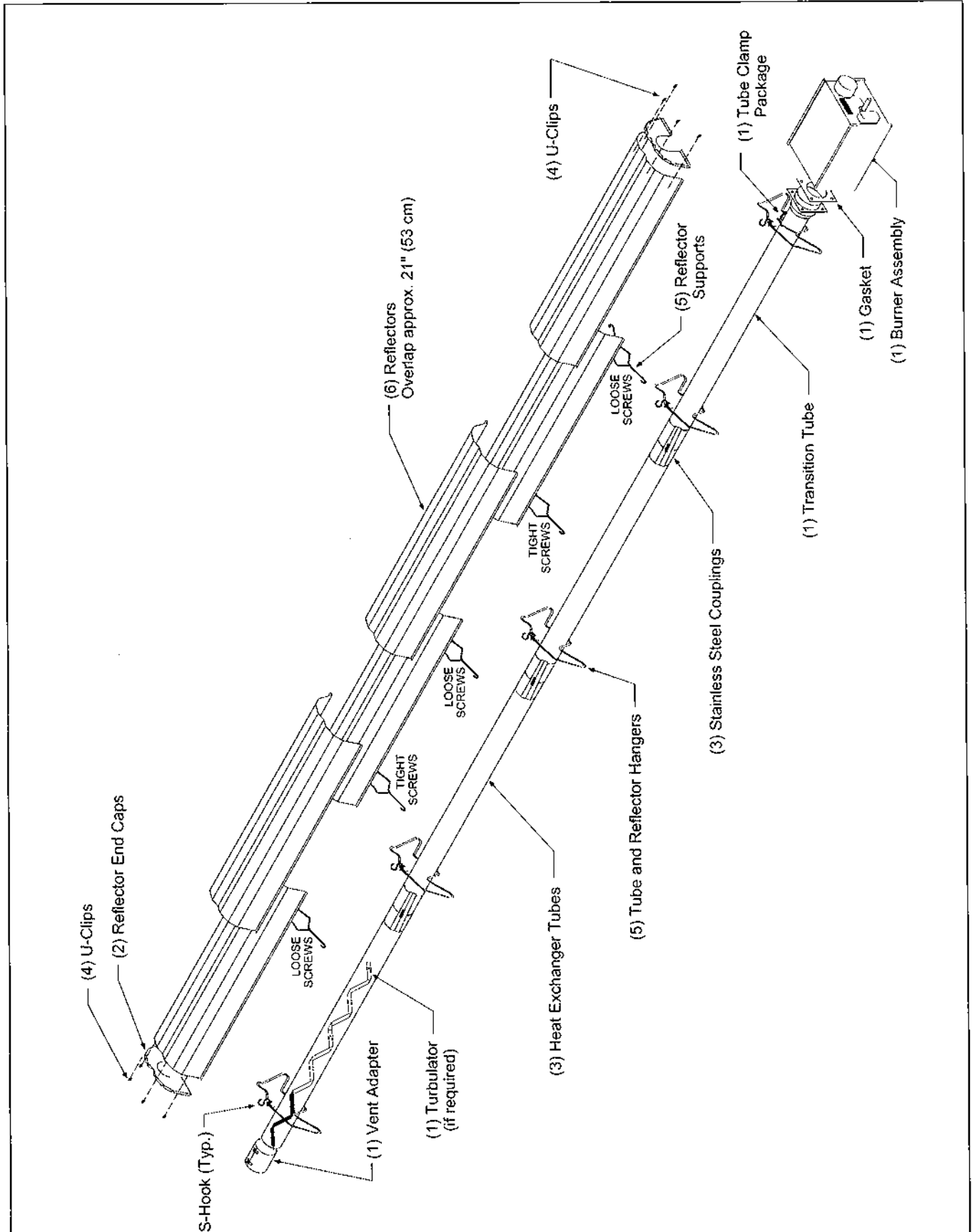

Figure 5. Assembly of 40 ft (12 m) Heat Exchanger System

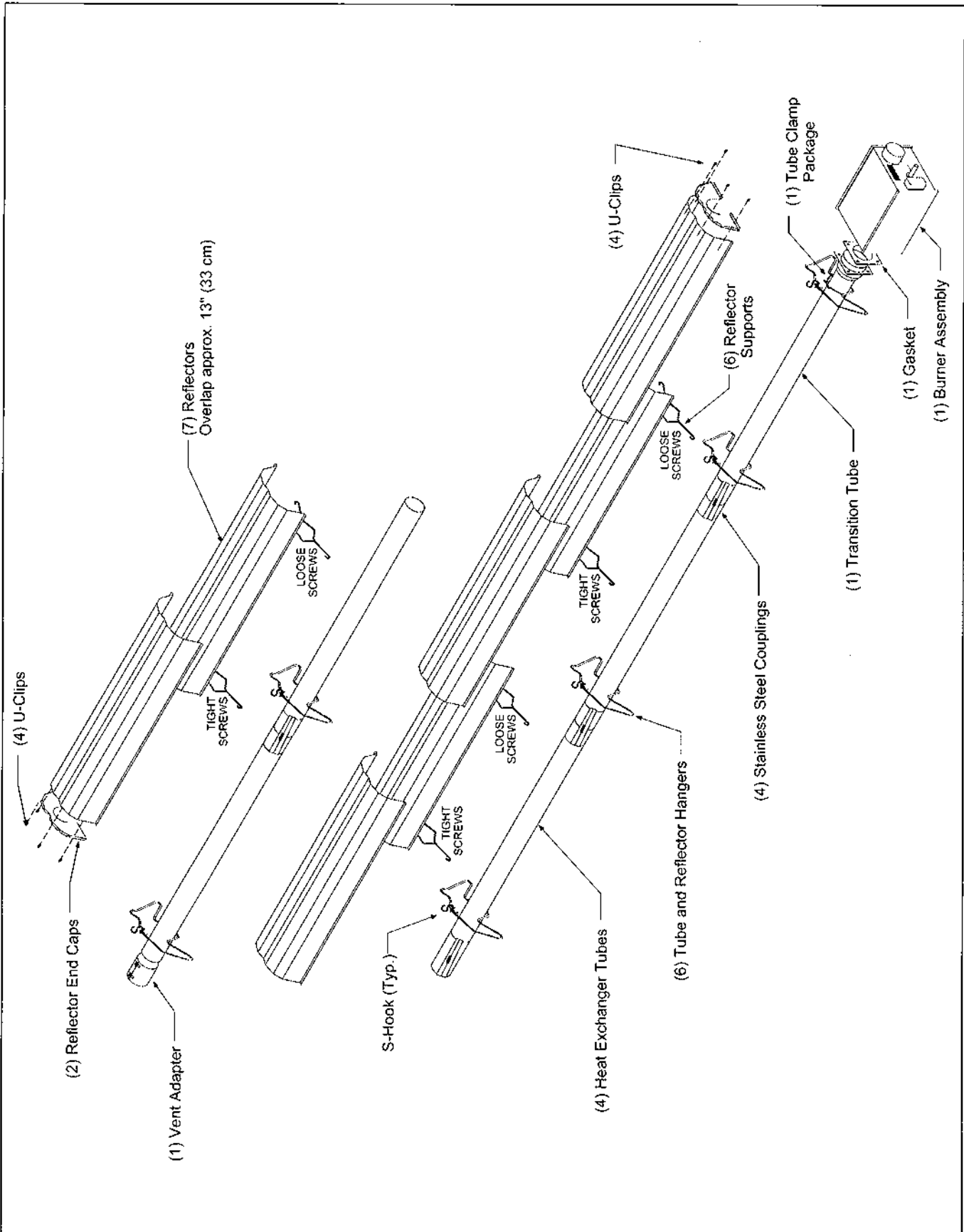

Figure 6. Assembly of 50 ft (15 m) Heat Exchanger System

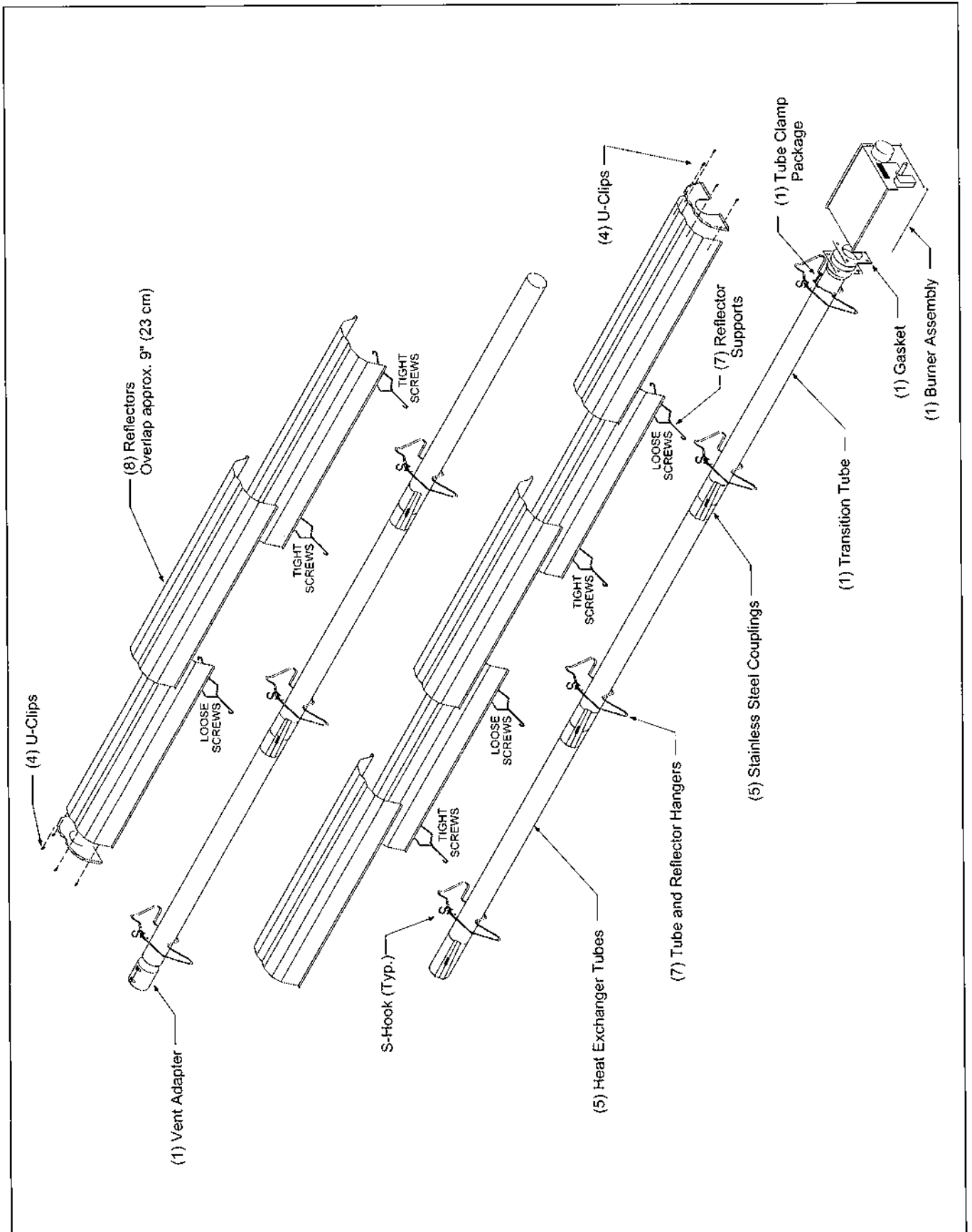

Figure 7. Assembly of 60 ft (18 m) Heat Exchanger System

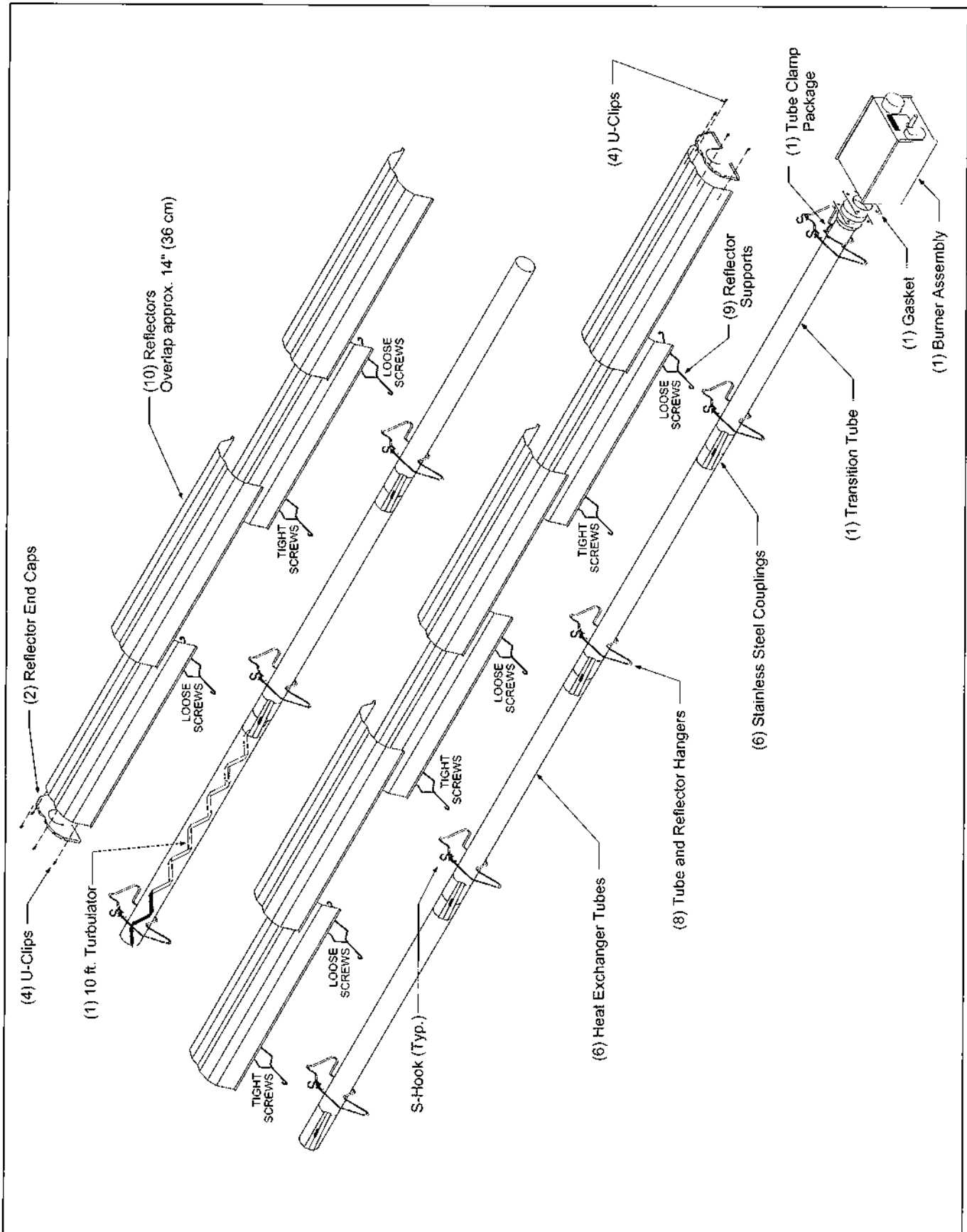

Figure 8. Assembly of 70 ft (21 m) Heat Exchanger System

► Section 7. Component Installation

TUBE COUPLING INSTALLATION

Tube and tube fittings are connected by wrap-around couplings which clamp by means of a tapered, hammer-driven lock member.

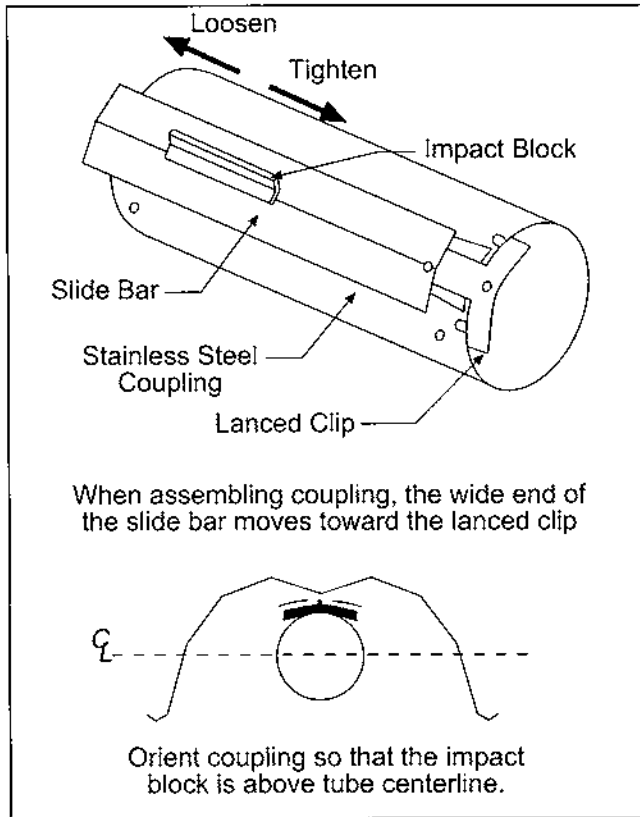

Figure 9. Coupling Assembly

To assemble the coupling, hook the free end of the coupling sleeve into the lanced clip. Place the wide end of the tapered slide bar on the coupling so that it moves toward the lanced clip. Insert the two tube ends into the coupling. Be sure the tube ends are in line and are flush against the stop pins inside the coupling.

Hammer-drive the slide bar until the coupling is secured snugly to the tubes. Overdriving the slide bar will distort the coupling or slide bar lip and will decrease the holding capability of the coupling. Coupling should be tight when the slide bar is $\pm 2"$ (5 cm) from the end of the coupling. See Figure 9.

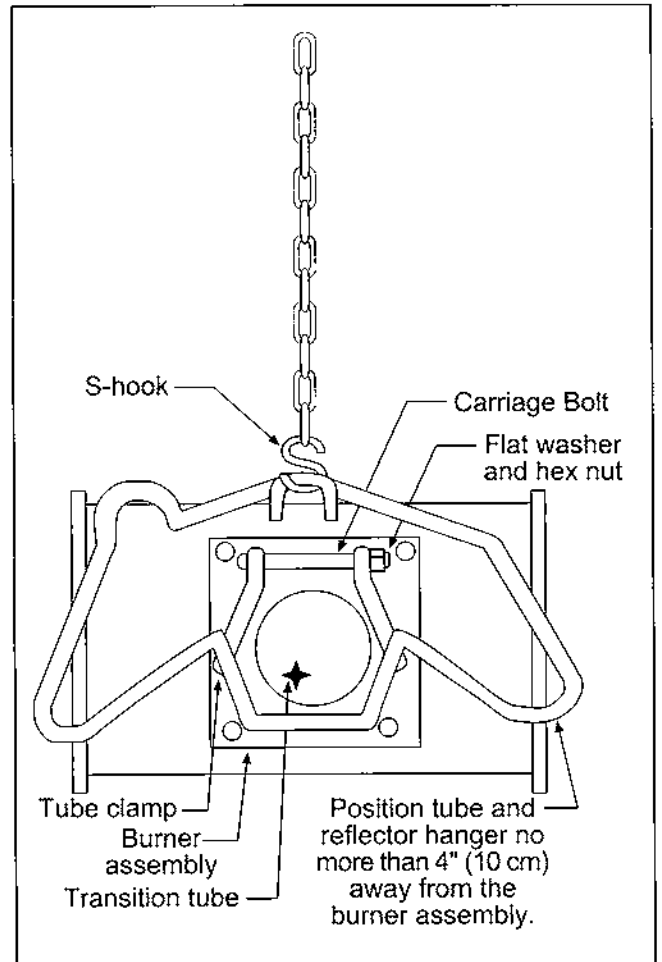

Figure 10. Tube Clamp Package

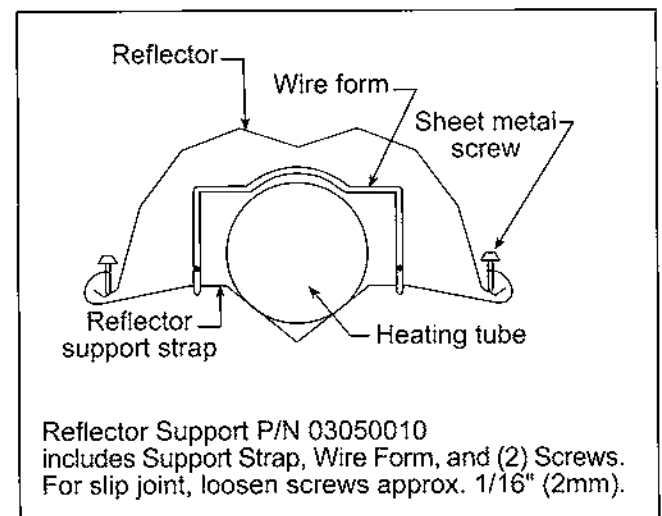

Figure 11. Reflector Support Package

ELBOW PACKAGE INSTALLATION

(P/N 02718702) Elbow Package includes: (1) elbow, (1) coupling, (1) end cap, (1) reflector joint piece, and (1) package of U-Clips. Install elbow into radiant tube sequence where plans indicate a 90° bend. Install reflector joint piece using the following procedure:

1. Flatten reflector edge where joint piece matches. Put a mark on the reflector, directly over the tube center. Center the accessory joint piece on the mark and scribe its contour on the reflector. Scribe the location of the mounting holes.
2. Cut away the reflector to clear the tube, leaving about one inch of material inside the scribed contour to attach the accessory joint. Drill or punch six 3/32" (2 mm) diameter holes in reflector in the positions shown in Figure 13.
3. Use six #10 sheet metal screws to attach the joint piece. Install a reflector end cap over the open end.

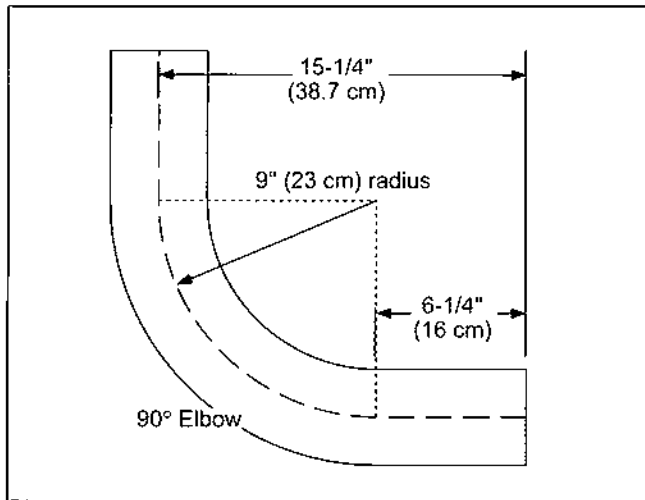

Figure 12. 90° Elbow Fitting Dimensions

REFLECTOR END CAP INSTALLATION

Reflector end caps must be installed over the open ends of reflectors. Attach the end cap to the reflector using a minimum of four U-clips per end cap.

Before installing the end cap, the center section must be removed. Carefully break the tabs on the bottom flange of the end cap first. Then gently flex the center section until it releases. Be very careful not to distort or otherwise damage the end cap during this procedure.

If the end cap is used at a joint piece to cover a 90° elbow or U-tube, the center section should not be removed.

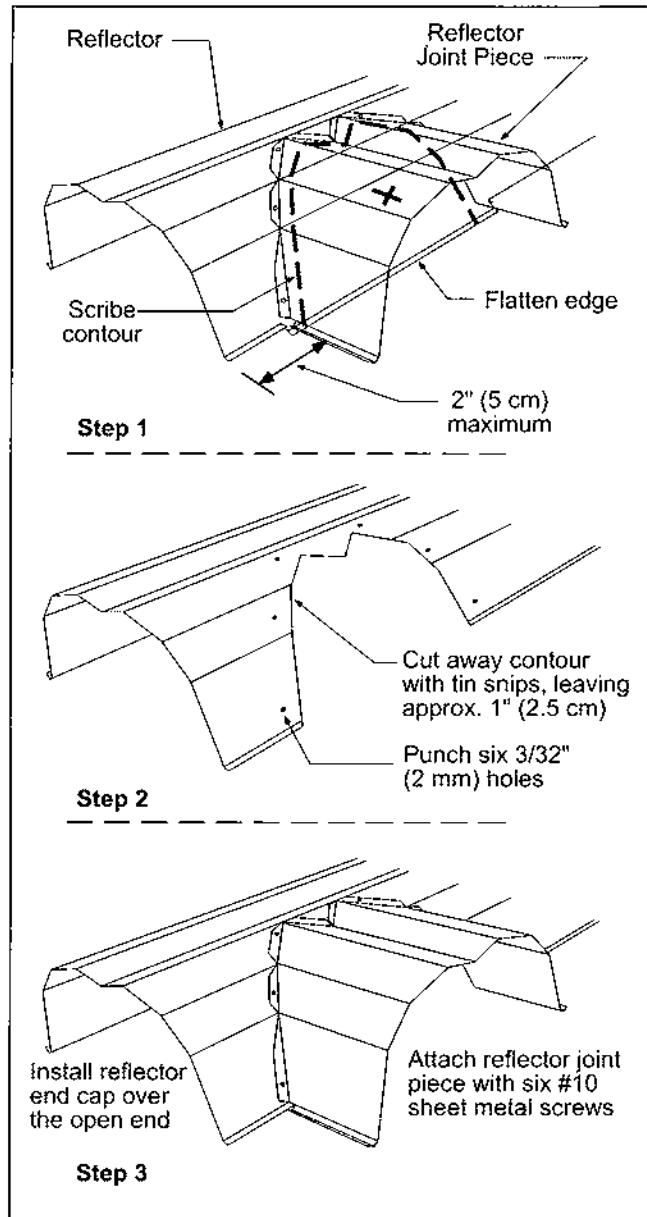

Figure 13. Reflector Joint Piece Installation

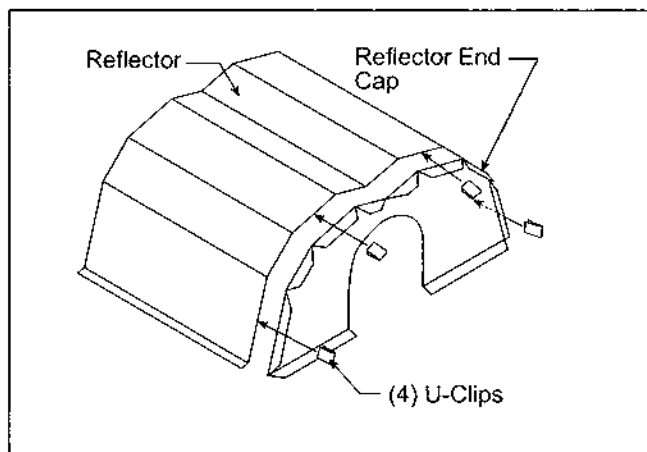

Figure 14. Reflector End Cap Installation

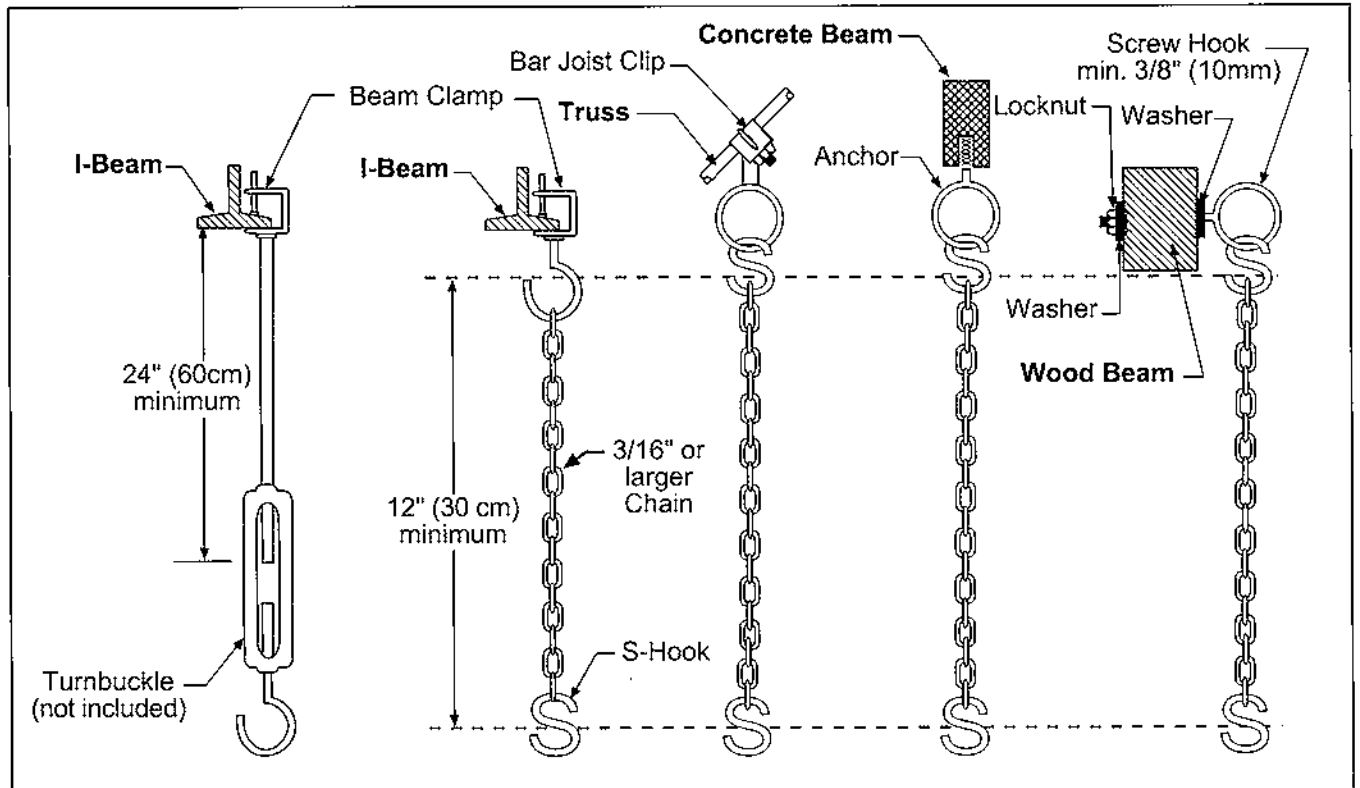

Figure 15. Typical Suspension Details

TURBULATOR INSTALLATION

For ease of installation, the turbulator should be installed in the tube before hanging the system. Use the following procedure (see Figure 16):

1. Assemble turbulator pieces by "twisting" matching ends together.
2. Insert a long wire (11 ft. minimum) down the length of the tube. Attach the wire to the hole in the tab on the adapter piece.
3. Using the wire, pull the assembled turbulator into the tube from the opposite end. Pull the turbulator through until just the tab comes out. Detach the wire.
4. Bend the tab around the tube. When installed, the vent adapter will lock the tab in place.

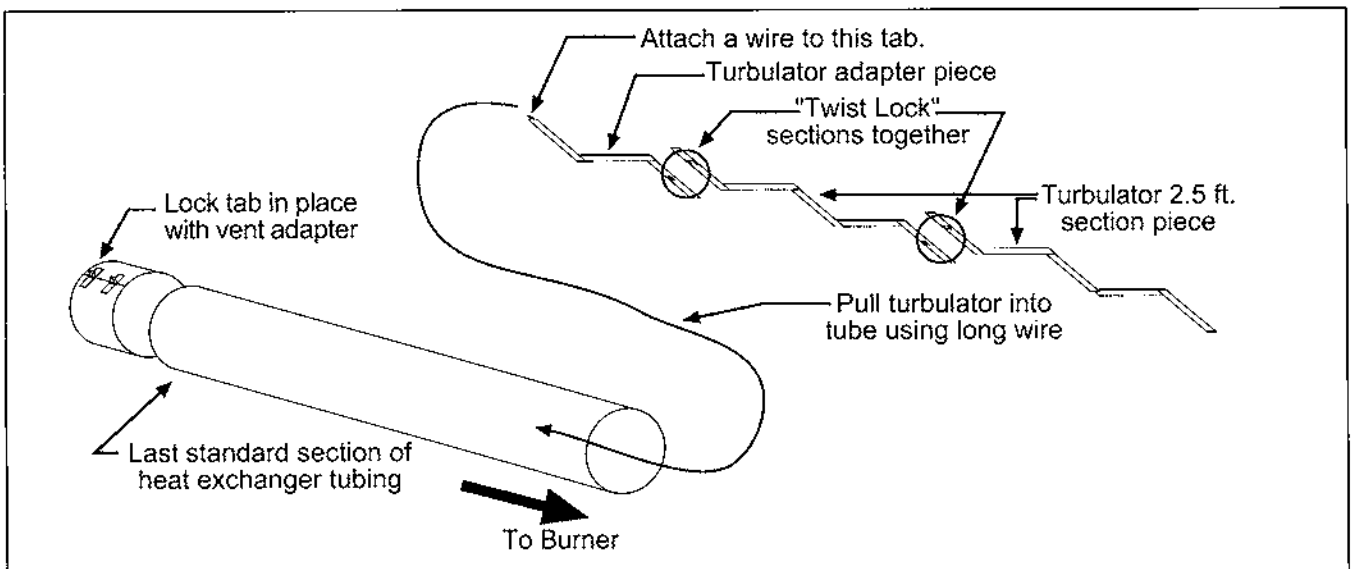

Figure 16. Turbulator Baffle Assembly Detail

SIDE EXTENSION REFLECTOR

Optional Side Extension Reflectors may be installed on either side of the unit. Each 8 ft. section of Side Reflector should match a reflector and have identical overlap to adjacent reflectors. Provide slip joints in the same locations as the reflectors. Proceed as follows (see Figure 17):

1. Attach a reflector side extension support bracket to the tubes where needed. These brackets should be located adjacent to the overlapped joints of the reflectors.
2. Insert lower edge of reflector side extension in extension support bracket.
3. Cut suitable relief notches where the side extension reflector meets tube and reflector hangers and reflector support brackets.
4. Hook the top edge of the side extension reflector over the edge of the reflector.
5. A slip joint must be provided in the perimeter side extension at the location of each slip joint in the reflector. The overlap should be the same as the reflector.
6. Where severe air movement may be encountered, as at a large door, one or two sheet metal screws should be used to attach the side extension reflectors together. Additional reflector supports are also recommended.
7. To Install the Retainer Clips: Lay bracket over the side extension reflector and standard reflector at the selected location. By using the hole in the clip as a template, drill or punch a 3/32" (2 mm) diameter pilot hole in the standard reflector. Secure the retainer clip using #8 x 3/8" sheet metal screws.

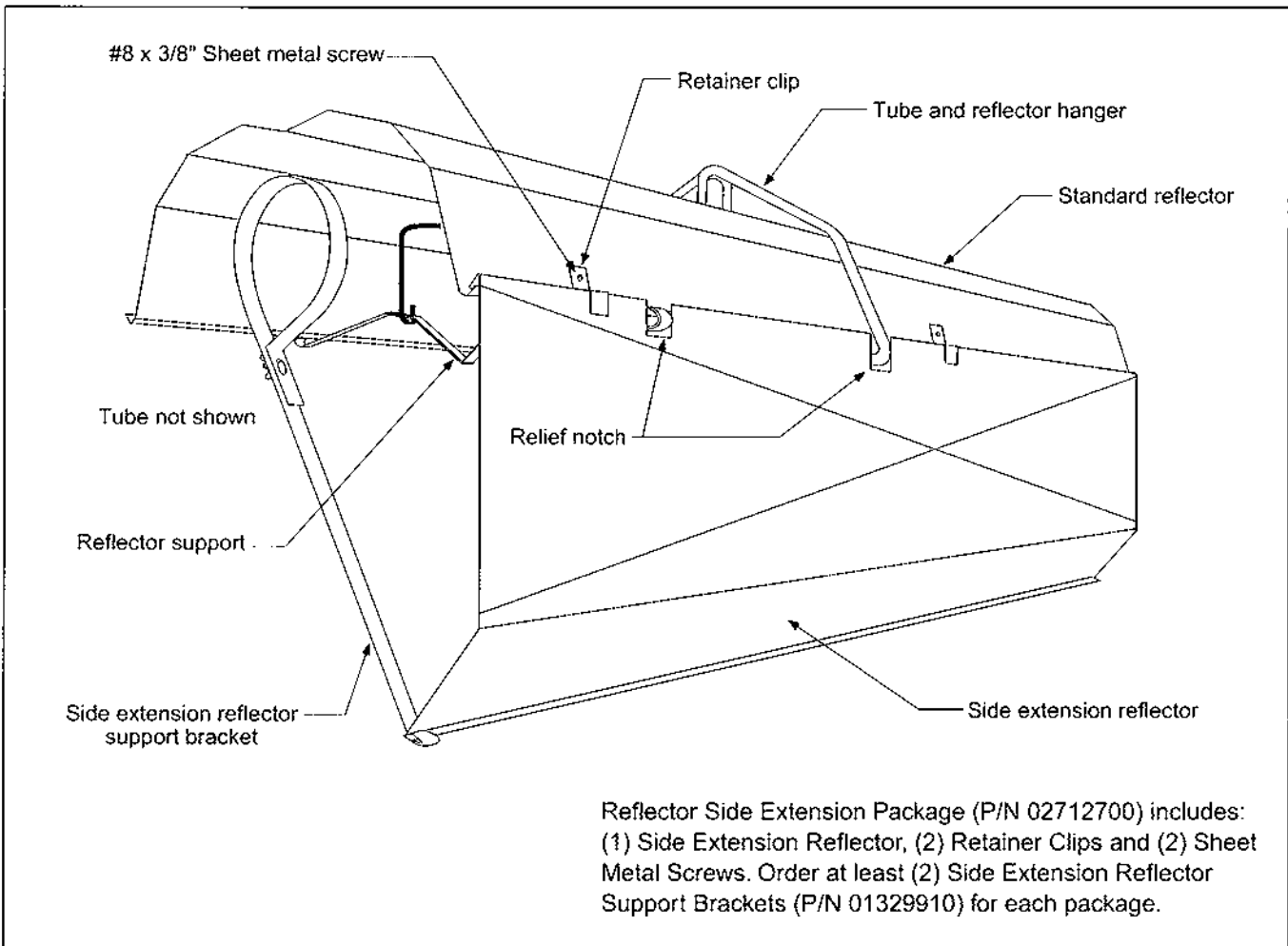

Figure 17. Installation of Side Extension Reflectors

U-TUBE PACKAGE

VANTAGE® II heaters (except CTH2-40) are approved for optional U-Tube configurations. The U-Tube Package (P/N 03011000) includes: (1) 180° U-Tube, (1) Plain Coupling, (1) Tube and Reflector Hanger, (2) End Caps, (1) U-Tube Support Bracket and (2) 4" (10 cm) U-Bolts with Lockwashers and Hex Nuts.

Shown below is an example CTH2-100 U-Tube configuration. One of the 10 ft. (3 m) tubes was cut in half to balance the sides. (The layout does not need to be symmetrical.) One (1) additional coupling was needed to complete the installation. The U-Tube may be installed in

either a standard horizontal position or in an opposite 45° position as shown below. When designing a U-Tube configuration, the following rules must be adhered to:

1. A minimum of 10 ft. (3 m) on CTH2-60/80 and a minimum of 15 ft. (4.5 m) on CTH2-100/125/150/175 is required between the burner and the U-Tube.
2. The correct turbulator must be installed in the last standard section of heater tube.
3. The burner must never be operated in a tilted position.
4. The heater must be properly supported at all locations.

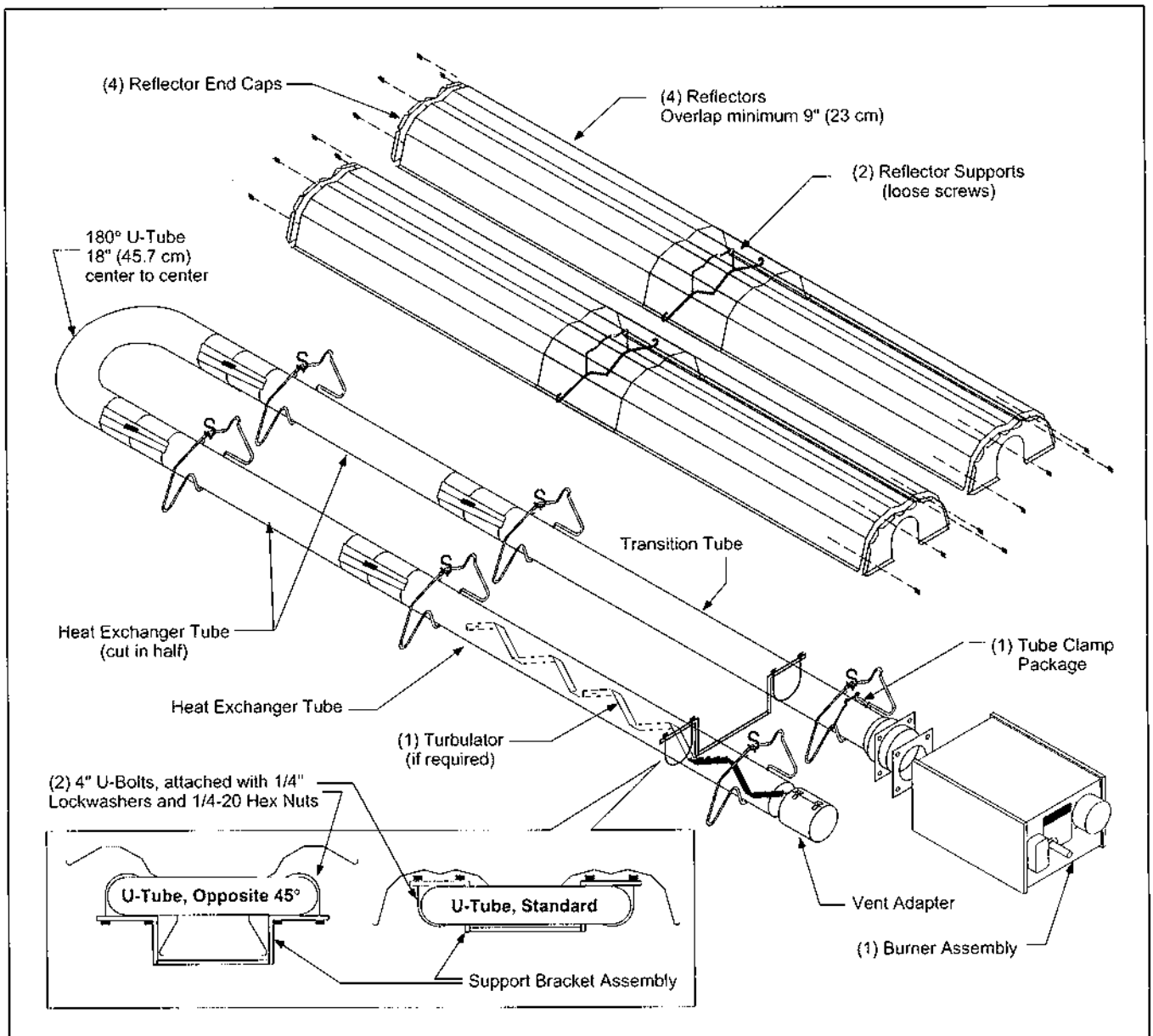

Figure 18. U-Tube Package Assembly Overview (optional)

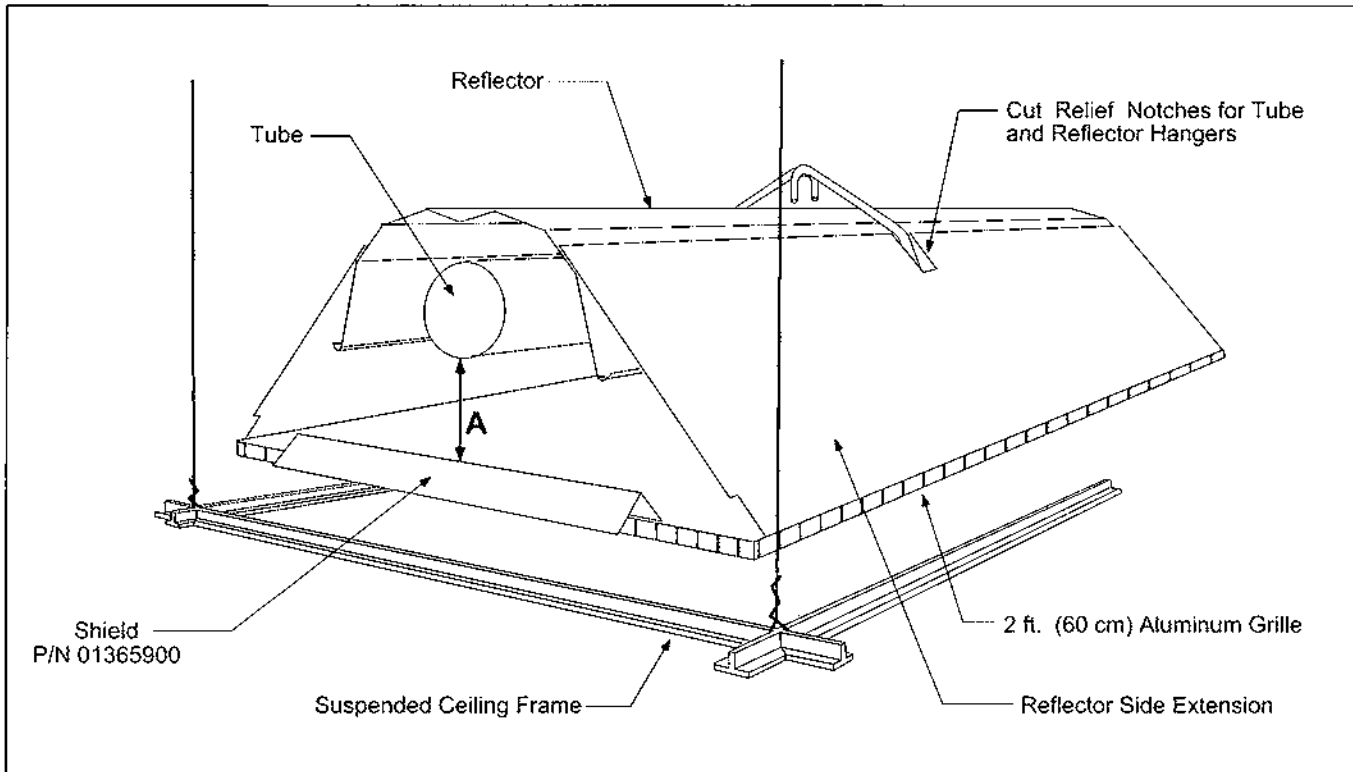

Figure 19. Installation of 2 ft. (60 cm) Decorative Aluminum Grille (optional)

DECORATIVE GRILLE INSTALLATION

⚠
WARNING

Cut Hazard

Wear protective gloves when handling aluminum grille.

Edges are sharp.

Failure to follow these instructions will result in injury.

The system is hung in a normal fashion with the tube suspended over the grille at a height between 1.6" and 14.4" (between 4.1 cm and 36.6 cm). To select the appropriate side extension reflectors, calculate the distance "A" between the radiant tube and the decorative grille. See Table 4 below.

Shields (P/N 01365900) must be placed over ceiling frame members that pass underneath the heater. The side extension reflectors are available in standard 4 ft. (120 cm) sections and have notches in the bottom corners to accommodate suspension system. Lay the side extension reflectors along the standard reflectors and cut suitable notches for the tube and reflector hangers where appropriate. It is generally not necessary to cut notches for the reflector support straps. Gloves should be worn when handling the aluminum grille to protect hands from sharp edges.

When running the heater over a suspended ceiling, decorative grille must be used directly below the heater. The use of regular ceiling tiles directly below the heater will create an unsafe condition.

The decorative grille option allows the heater to be installed over suspended ceilings. The aluminum grille (P/N 91407000) comes in standard 2 ft. x 4 ft. (60 cm x 120 cm) sections and is installed in place of ceiling tile.

Table 4. Side Extensions for Decorative Grille

Distance "A"		Extension	
Minimum	Maximum	Part No.	Width
1.6" (4.1 cm)	5.8" (14.6 cm)	01370408	8" (20 cm)
5.8" (14.6 cm)	10.1" (25.7 cm)	01370412	12" (30 cm)
10.1" (25.7 cm)	14.4" (36.6 cm)	01370416	16" (40 cm)

► Section 8. Venting and Ducting

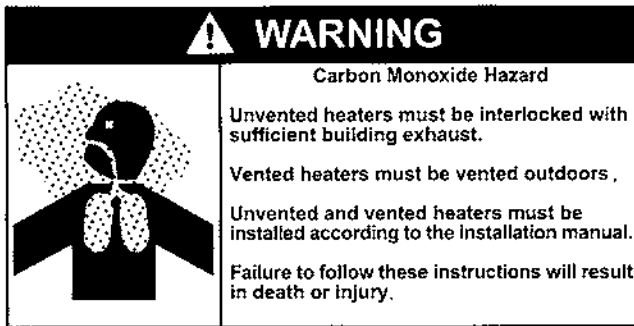

Heater must be vented in accordance with the proper national and local codes. Partial information relating to these specifications is provided in this section with regard to size and configurations for venting arrangements. **United States:** refer to ANSI Z223.1 - latest revision. **Canada:** refer to CAN/CGA-B149.1 and B149.2

Heater may be vented one of the following ways:

Unvented (with adequate ventilation)	pg. 24
Horizontal Venting - Combustible walls	pg. 24
Horizontal Venting - Noncombustible walls	pg. 24
Common Side Wall Venting	pg. 25
Vertical Venting without Draft Hood	pg. 26
Common Vertical Venting	pg. 27

The method chosen will depend upon a number of factors including: building ventilation, available access points in walls and ceiling, number of burners installed, installation codes, etc. Consult layout drawing for venting method used. Some installations may require the use of an outside combustion air supply. See page 28 for details.

General Venting Requirements

Use the following guidelines to help insure an adequate, safe venting arrangement:

- Exhaust end of heater will accept a four inch vent pipe using the vent adapter (P/N 90502700). Install the vent adapter with the seam on top. This will prevent condensation from leaking out of the adapter.
- Vent terminal opening must be beyond any combustible overhang.
- If condensation in the vent is a problem, the vent length should be shortened or insulated.

- For outside air installations, the outside air terminal must not be installed more than one foot above the vent terminal.
- Secure all joints with minimum (3) #8 x 3/8 sheet metal screws
- All vent joints should be sealed using suitable product such as General Electric RTV106 or Permatex Form-a-Gasket red high temperature silicone adhesive sealant.

Vent Length Requirements

- Maximum vent length allowed is 45 ft. (13.7 m).
- Maximum outside air supply duct allowed is 45 ft. (13.7 m).
- Vent length plus outside air supply length plus extension package shall not exceed 65 ft. (19.8 m).
- Under length conditions a) through c) above, a total of 2 elbows are allowed for vent and outside air supply together. Subtract 15 ft. (4.6 m) per additional elbow from maximum length allowed if more than 2 elbows are used.

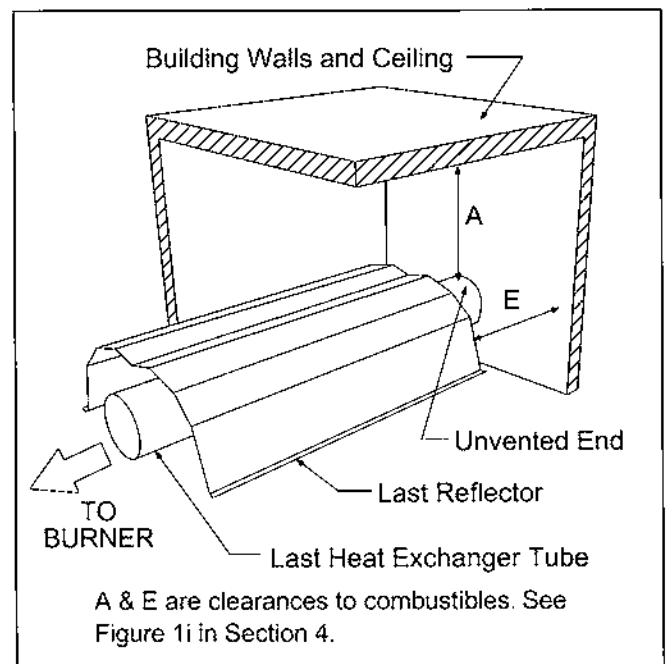

Figure 20. Unvented Operation

UNVENTED OPERATION (See Figure 20)

- a) Sufficient ventilation must be provided in the amount of 4 cfm per 1000 BTU/hr firing rate (**United States**); 3 cfm per 1000 BTU/hr firing rate (**Canada**).
- b) Use of optional outside combustion air is not recommended with unvented heaters due to pressure considerations.
- c) If exhaust fans are used to supply ventilation air, an interlock switch must be used to prevent the heater from coming on when the fans are off. This may be done using an air pressure switch.
- d) For additional information: **United States**: refer to ANSI Z223.1 - latest revision (NFPA No. 54) and local codes; **Canada**: CAN/CGA-B149.1 and B149.2 Installation Codes.

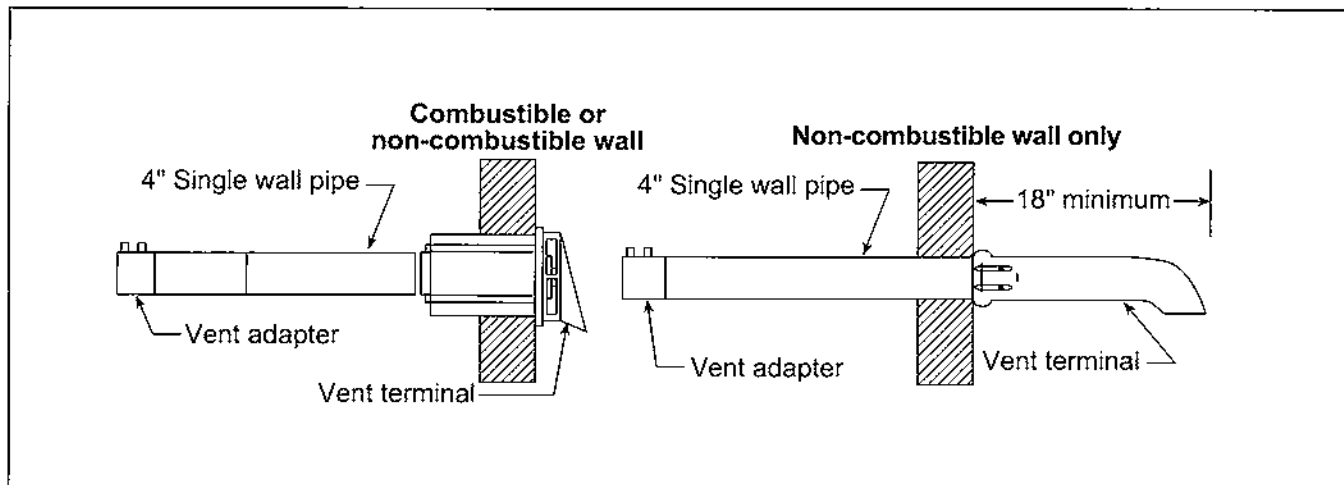

Figure 21. Horizontal Venting Configurations

HORIZONTAL VENTING (See Figure 21)

- a) In combustible or noncombustible walls use insulated vent terminal (P/N 90502100, Tjernlund VH1-4 or equivalent). Follow vent manufacturer's instructions for proper installation.
- b) For noncombustible walls only, use vent terminal (P/N 02537800).
- c) 4" O.D. vent pipe is required, 30 ft. (9 m) maximum length is recommended. Up to 45 ft. (13.7 m) maximum may be used if insulated to prevent excess condensation.
- d) Vent terminal should be installed at a height sufficient to prevent blockage by snow. Building materials should be protected from degradation by vent gases.
- e) Insure the vent pipe has a downward pitch of 1/2" per 20 feet away from the burner.

Requirements (United States)

- a) Vent must exit building not less than seven feet above grade when located adjacent to public walkways.
- b) Vent must terminate at least three feet above any forced air inlet located within ten feet.
- c) Vent must terminate at least four feet below, four feet horizontally from, or one foot above any door, window, or gravity inlet into any building.
- d) Vent terminal shall be located at least 1 ft. (30 cm) from any opening through which vent gases could enter a building.

Requirements (Canada)

- a) Vent terminal must not be installed less than 3 ft. (1 m) from any building opening.
- b) Vent must be at least 6 ft. (2 m) from the combustion air opening of this unit or any other appliance.
- c) Vent terminal must be installed at least 3 ft. (1 m) above grade.

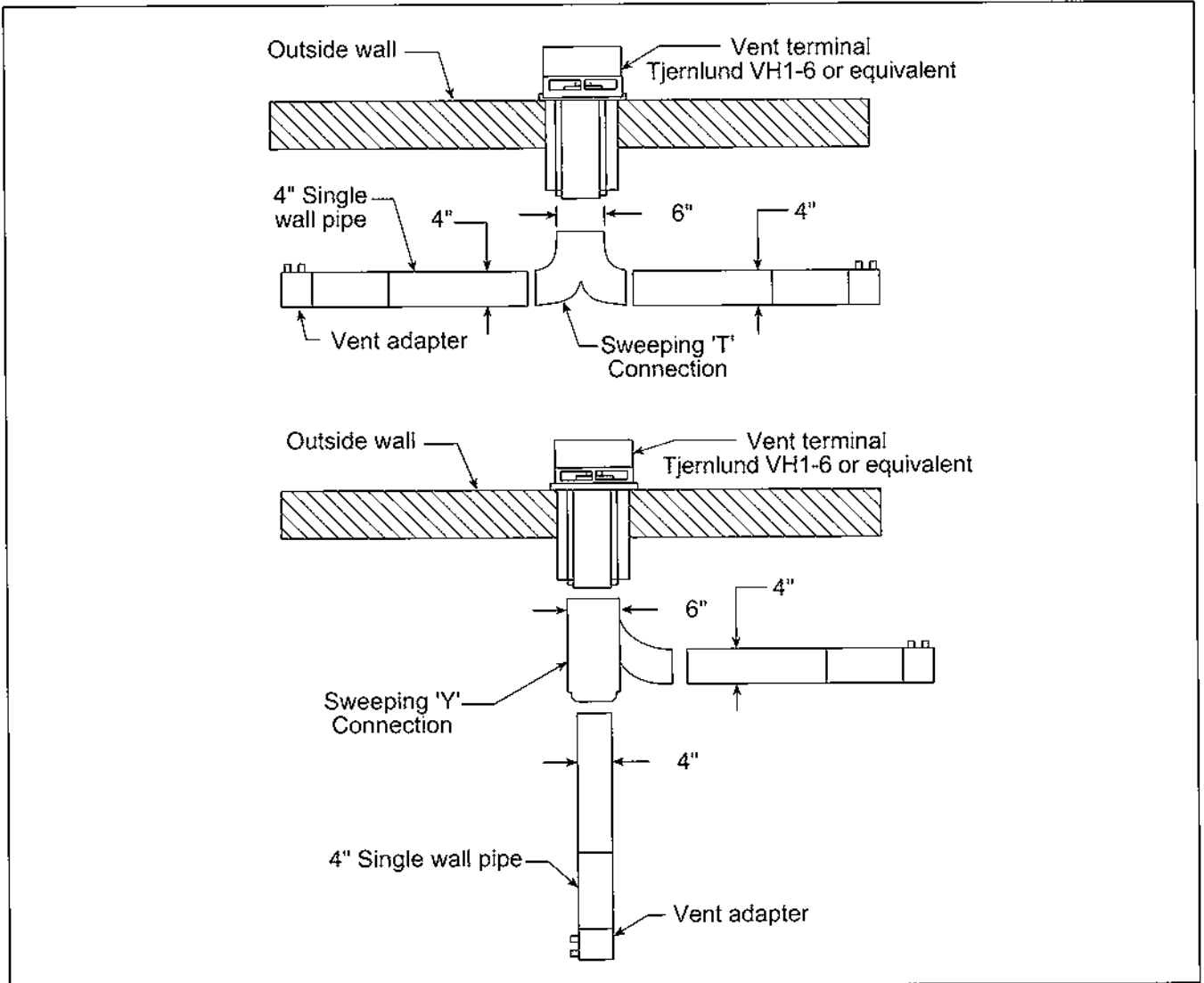

Figure 22. Common Side Wall Venting Configurations

COMMON SIDE WALL VENTING (See Figure 22)

Requirements

- a) Maximum of two units may be vented together into a 6" diameter common vent.
- b) Units must be of the same BTU input.
- c) Units must be controlled from one common thermostat.
- d) Use a sweeping tee, or sweeping Y connection. These connections may be purchased from any sheet metal fitting manufacturer.

Recommendations

Although not compulsory, an outside air supply to the burners is recommended.

VERTICAL VENTING (See Figure 23)

- a) In the United States refer to ANSI Z223.1 - latest revision, (NFPA No. 54) for proper vent sizes and installation.
- b) In Canada refer to CAN/CGA-B149.1 and B149.2 for proper vent sizes and installation.
- c) Type "B" vent materials must be used outdoors.
- d) An insulating thimble may be required to pass through combustible structures.
- e) 4" O.D. vent pipe, maximum 45 ft. (13.7 m) in length may be used as shown above with an approved vent cap.

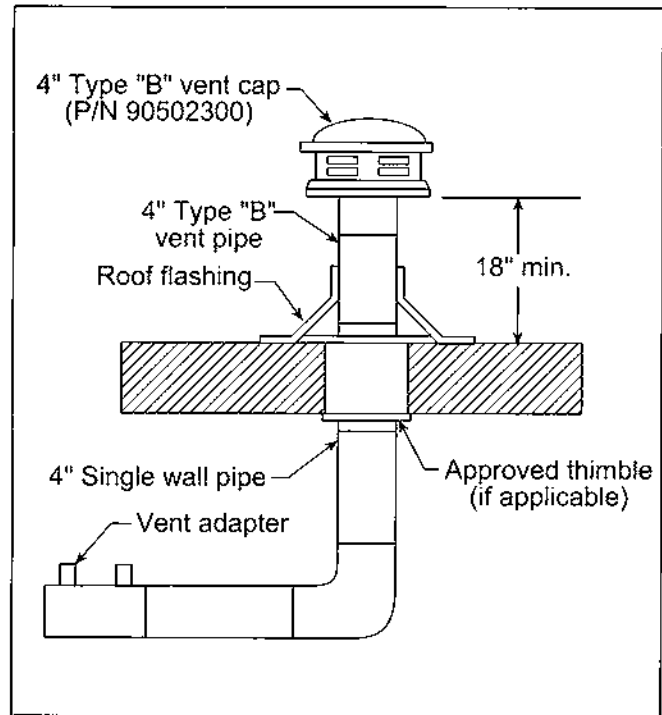

Figure 23. Vertical Venting Configuration

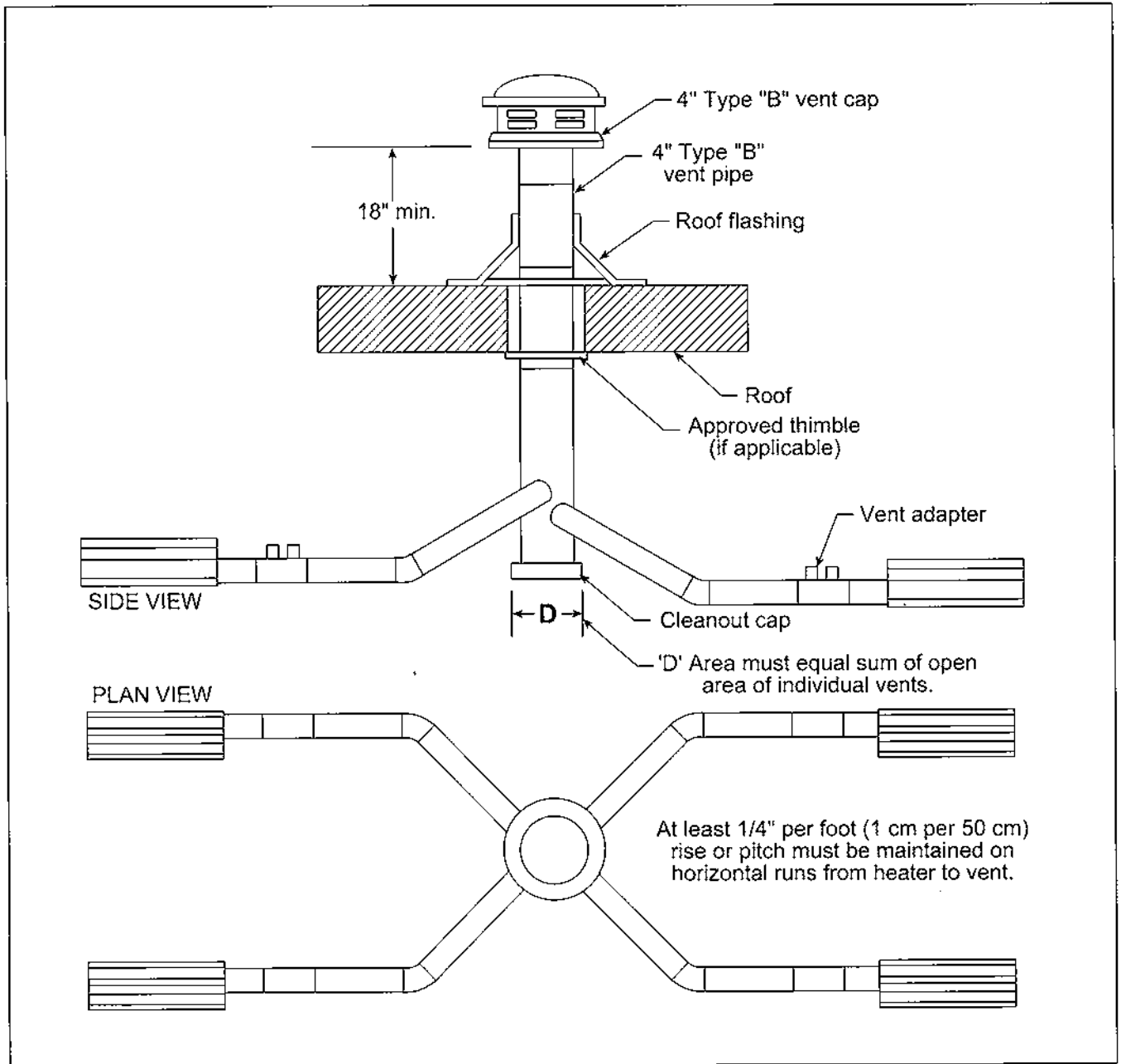

Figure 24. Common Vertical Venting

Common Vertical Venting (See Figure 24)

- a) Open area of common vent must equal the sum of the open area of individual vents connected to it.
- b) Heaters sharing a common vent must be controlled by the same thermostat.
- c) Connections to common stack must be positioned to avoid direct opposition between streams of combustion gases.
- d) Maximum horizontal length of vent to common vent 15 feet (5m). Maximum vertical vent 15 feet (5m).

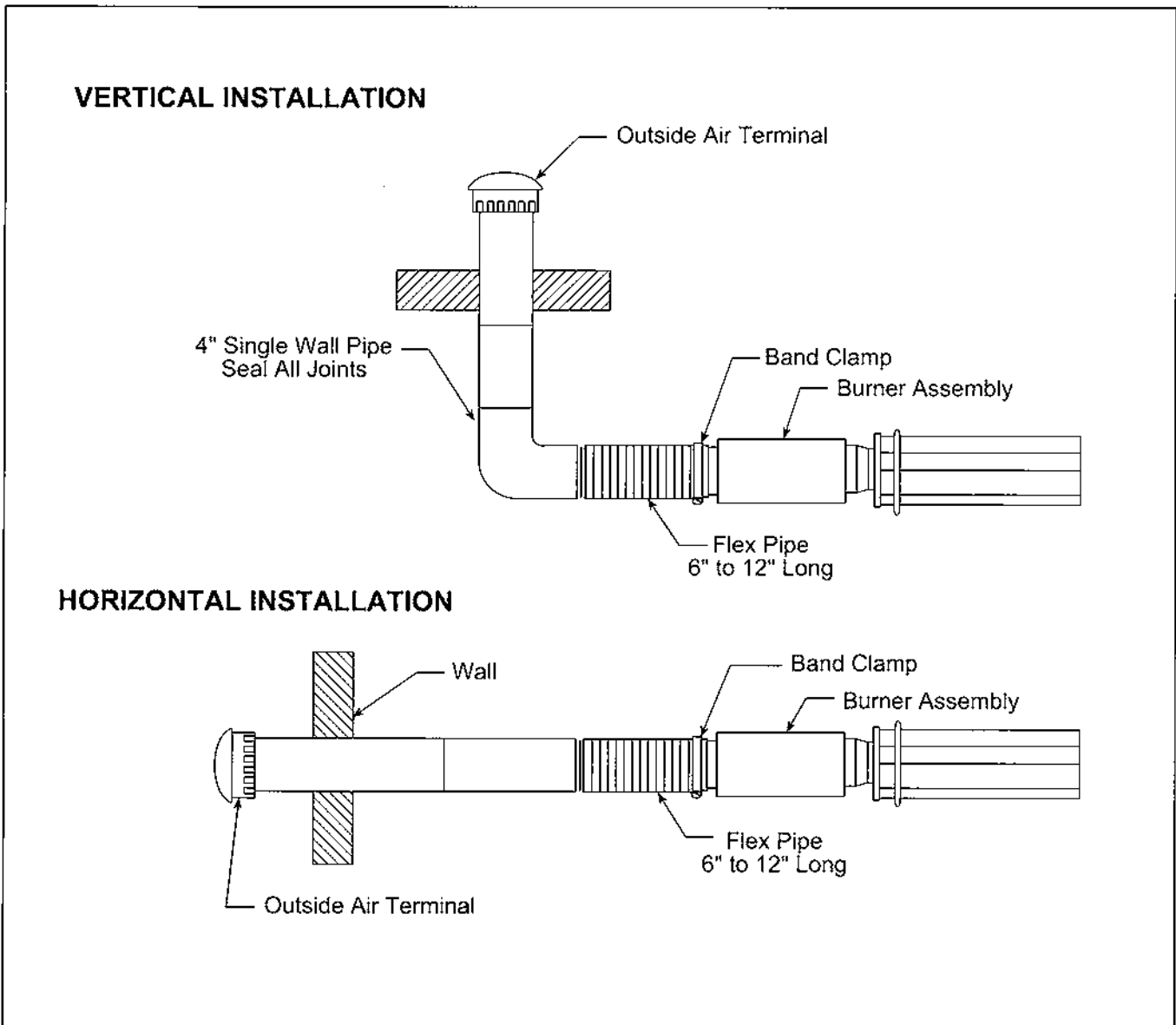

Figure 25. Non-Pressurized Outside Air Supply For Single Heater Installations

OUTSIDE COMBUSTION AIR SUPPLY

IMPORTANT: If the building has a slight negative pressure or contaminants such as halogenated hydrocarbons are present in the air, an outside combustion air supply to the heaters is strongly recommended.

The VANTAGE® II heater is approved for installation with an outside air supply system. An outside air supply should not be used with the draft hood venting configuration.

For an outside air supply, a 4" O.D. (10 cm O.D.) single wall pipe may be attached to the heater. The duct may be up to 45 ft. (13.7 m) maximum length or 2 ft. (60 cm) minimum length with no more than 2 elbows. See Vent

Length Requirements heading on pg. 23 for more detailed guidelines.

The air supply duct may have to be insulated to prevent condensation on the outer surface. The outside air terminal should be securely fastened to the outside wall by drilling four 1/4" (6 mm) diameter holes in the outside flange; wood screws or bolts and expansion sleeves may be used to fasten the terminal.

For the outside air terminal, use Metalbestos #31267 (RG P/N 90502300), or ACME #104, or equivalent.

PVC pipe, aluminum flex duct, or equivalent may be used instead of single wall pipe for the outside combustion air supply.

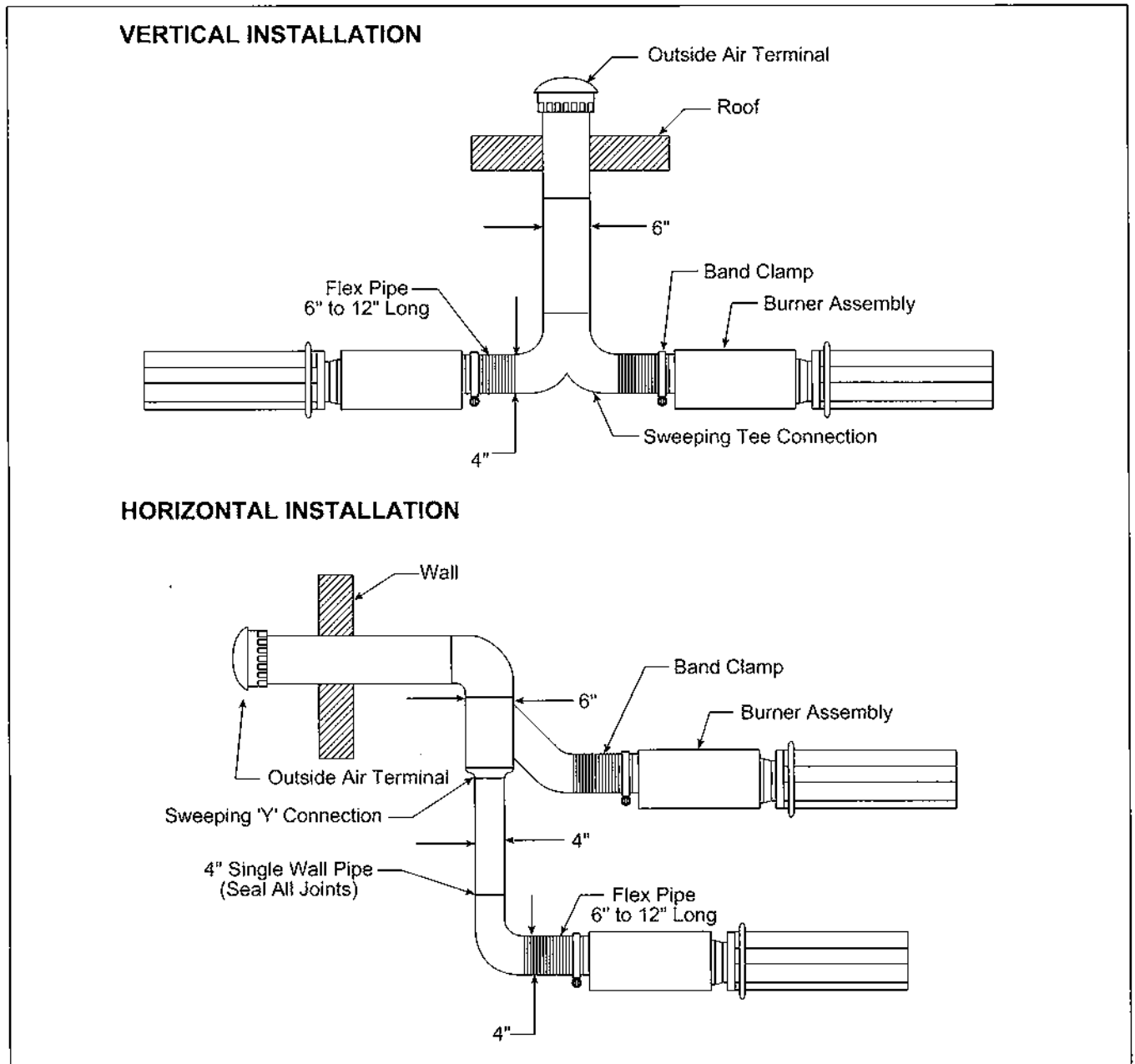

Figure 26. Non-Pressurized Outside Air Supply for a Maximum of Two Heaters Controlled by a Common Thermostat

OUTSIDE COMBUSTION AIR SUPPLY (CONTINUED)

When air is supplied for combustion to a maximum of two heaters through a common duct, the following rules apply:



1. Follow the venting rules on page 23 for detailed guidelines.
2. The two units must be controlled by a common thermostat.
3. Use 4" O.D. (10 cm O.D.) single wall or PVC pipe between the heater connection and the common source. The common source will be a minimum of 6" O.D. single wall or PVC pipe.

4. Combined length of the 4" and 6" pipe shall not exceed 45 feet (13.7 m) with 2 elbows maximum per unit (see Fig. 27). See also Vent Length Requirements heading on page 23 for more detailed guidelines.

5. Entry of the 4" pipes will not oppose one another.

Example: 4 feet of 6" O.D. (15 cm O.D.) common supply air pipe and one 6"x4"x4" tee are attached to 4" pipe x 4 feet long, attached to VANTAGE® II units. This will limit the flue length to 45 feet of 4" pipe.

► Section 9. Gas Piping

⚠ WARNING	
	
Fire Hazard Connect gas according to Figure 27. Gas line moves during operation. Failure to follow these instructions will result in death, injury or property damage.	Explosion Hazard Do not pressure test the gas pipe with the burner connected. Failure to follow these instructions will result in death, injury or property damage.

A 1/2" gas supply connection at each burner location must be located and oriented as shown in Figure 27. To check system pressure, put a plugged 1/8" NPT tapping in the gas line at the connection to the burner furthest from the supply. Before connecting the burners to the supply system, verify that all high pressure testing of the gas piping has been completed.

Follow these instructions to ensure a professional gas supply system installation:

- Support all gas piping with suitable pipe hanging materials.
- Use wrought iron or wrought steel pipe and malleable iron fittings. All pipe and fittings should be new and free from defects. Carefully ream the pipe and tubing ends to remove obstructions and burrs.
- Use LP-gas-resistant joint compound on all threads.
- Check the pipe and tubing ends for leaks before placing heating equipment into service. When checking for gas leaks, use a soap and water solution; never use an open flame.

Install the flex gas connector as shown. The flex gas connector accommodates expansion of the heating system and allows for easy installation and service of the burner.

Read applicable warnings in Section 1 before proceeding with Gas Piping installation.

Meter and service must be large enough to handle all the burners being installed plus any other connected load. The gas line which feeds the system must be large enough to supply the required gas with a maximum pressure drop of 1/2" w.c. When gas piping is not included in the layout drawing the local gas supplier will usually help in planning the gas piping.

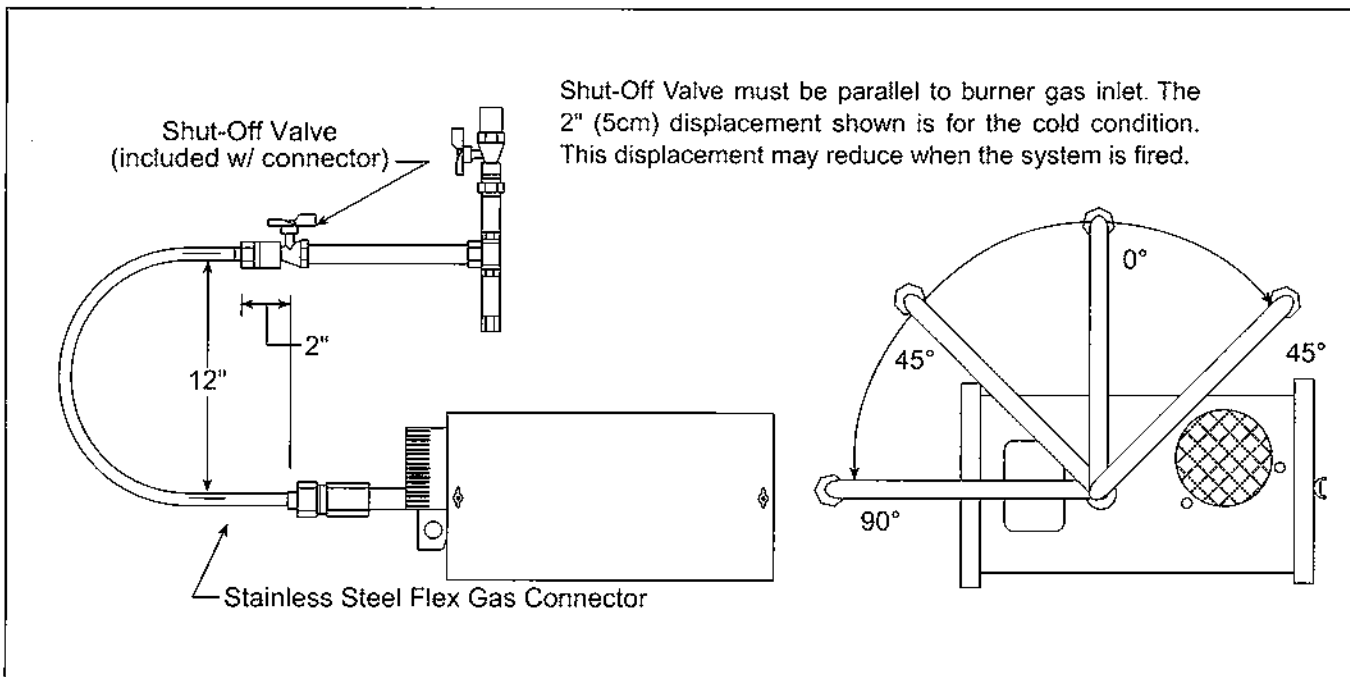



Figure 27. Gas Line Connection with Stainless Steel Flex Gas Connector

► Section 10. Wiring

⚠ WARNING		⚠ ATTENTION
<p>Electrical Shock Hazard Disconnect electrical power before servicing. Replace door before operating. Failure to follow these instructions will result in death or electrical shock.</p>		<p>Risque d'électrocution Débranchez le courant électrique avant toute révision. Remplacez la porte avant la mise en marche. Le non-respect de ces consignes peut entraîner mort ou électrocution.</p> <p style="text-align: right; font-size: small;">© P/N 91037901</p>

Heaters can be controlled using several methods. Normally thermostats are used to control the heaters but they can also be controlled by an Energy Management System. Figure 28 illustrates the connection for heaters controlled by a line voltage thermostat NOTE: in order to use line voltage thermostats the low voltage terminal located at the back of each burner must be connected as shown in detail. Figure 29a & b illustrates control schemes that incorporate a low voltage thermostat. For single heater on a low voltage thermostat use figure 29a. If it is desired to control multiple heaters on one low voltage thermostat then use figure 29b in order to control multiple heaters on one low voltage thermostat the low voltage terminals on each heater must be connected as shown in detail. Heaters must be grounded in accordance with applicable codes: United States: refer to National Electric Code ANSI/NFPA 70 - latest version Canada: refer to Canadian Electrical Code CSA C22.1 Part I - latest revision.

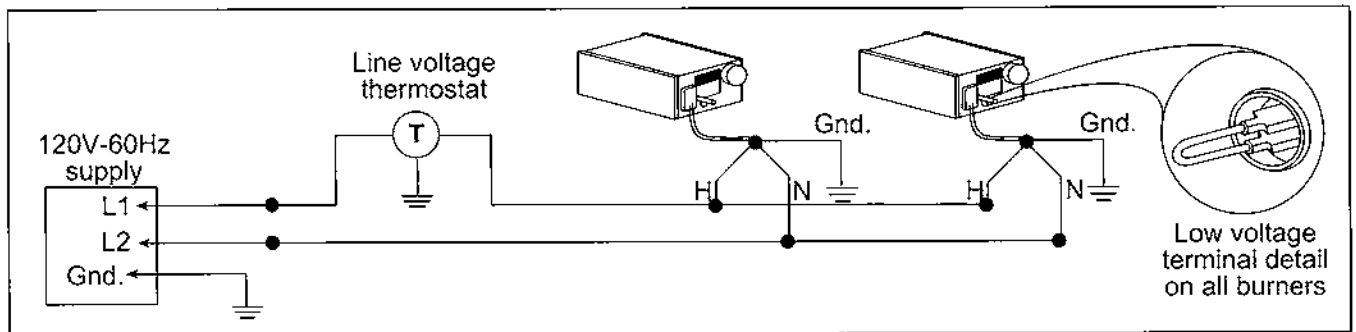

Figure 28. Line Voltage Thermostat Wiring

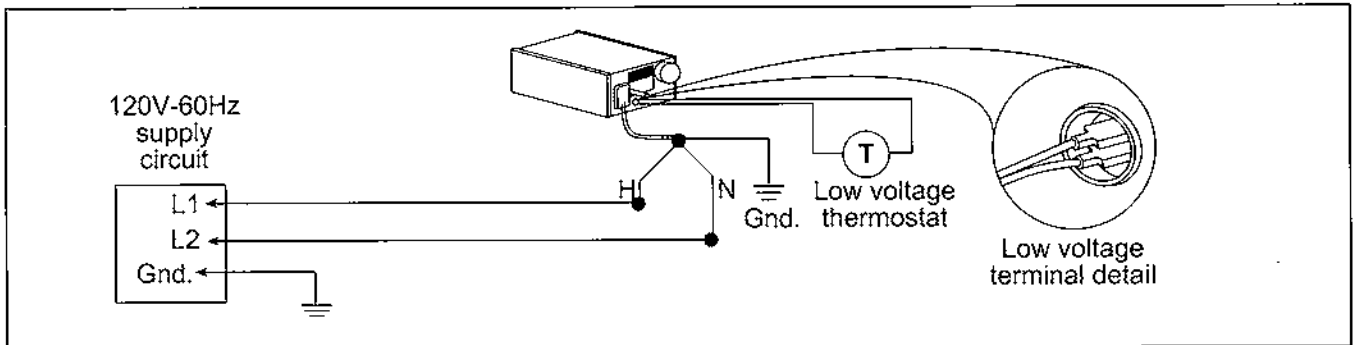

Figure 29a. Low Voltage Thermostat on One Burner

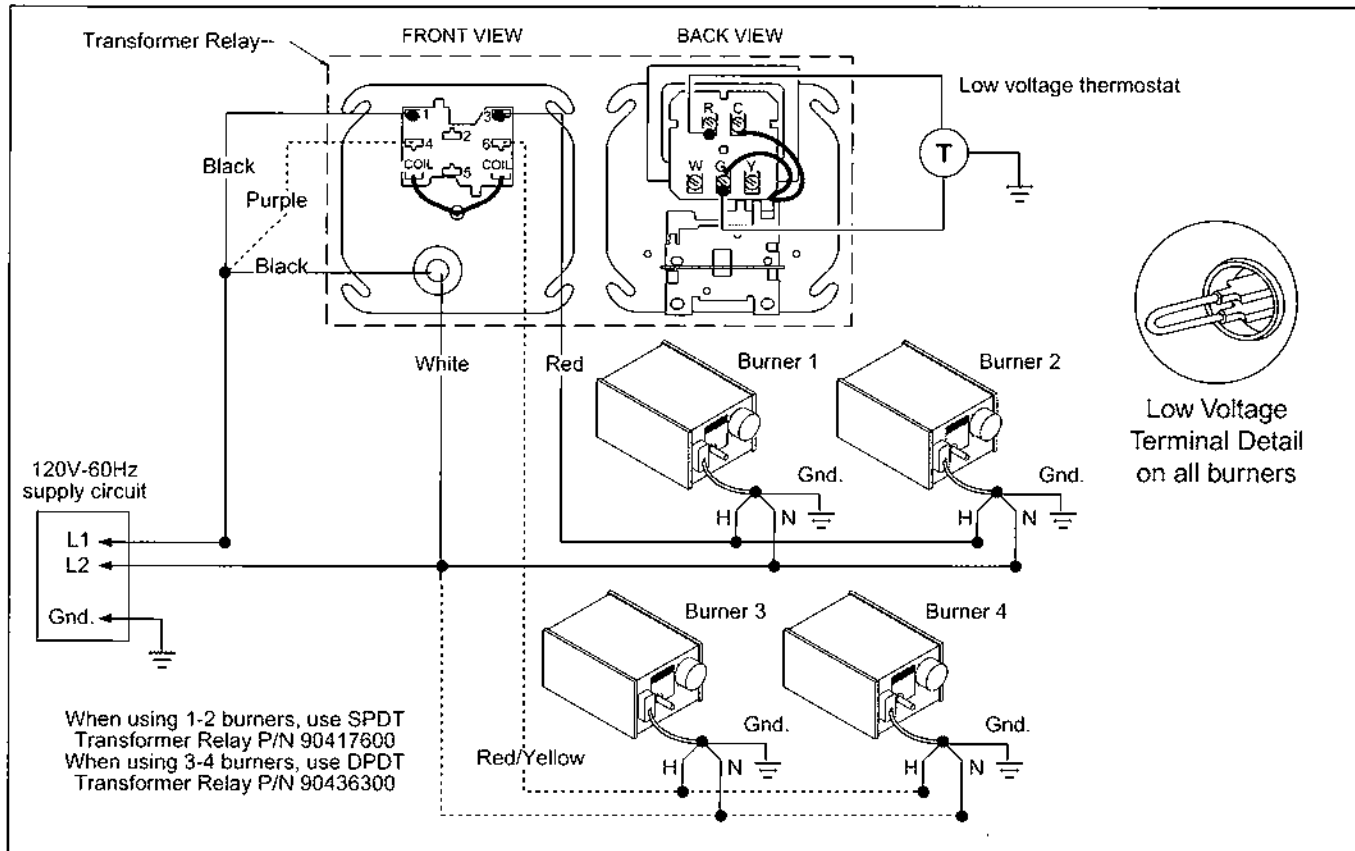

Figure 29b. Low Voltage Thermostat and Relay Wiring

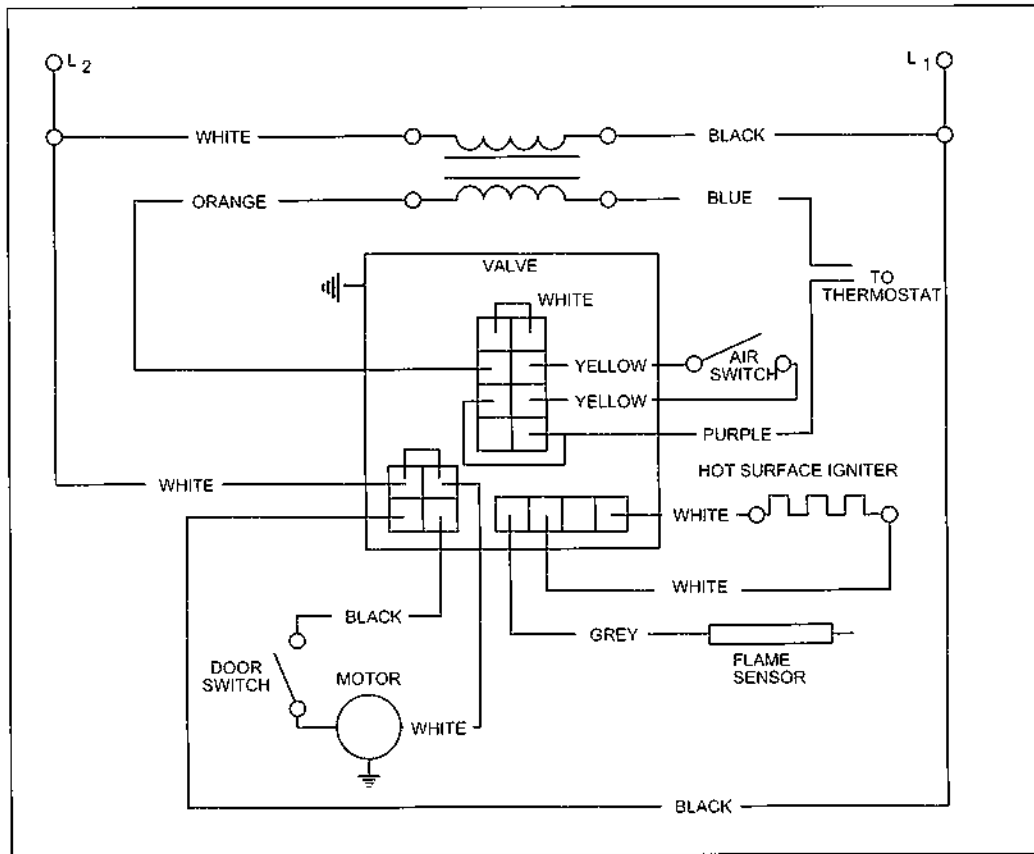

Figure 30. Burner Ladder Diagram

⚠ WARNING	⚠ ATTENTION
<p>If any of the original wire as supplied with the heater must be replaced, it must be replaced with wiring material having a temperature rating of at least 105°C and 600 volts.</p>	<p>Si une partie du câblage d'origine fourni avec le radiateur doit être remplacée, elle doit l'être par du matériel de câblage tolérant une température d'au moins 105°C et 600 volts.</p>

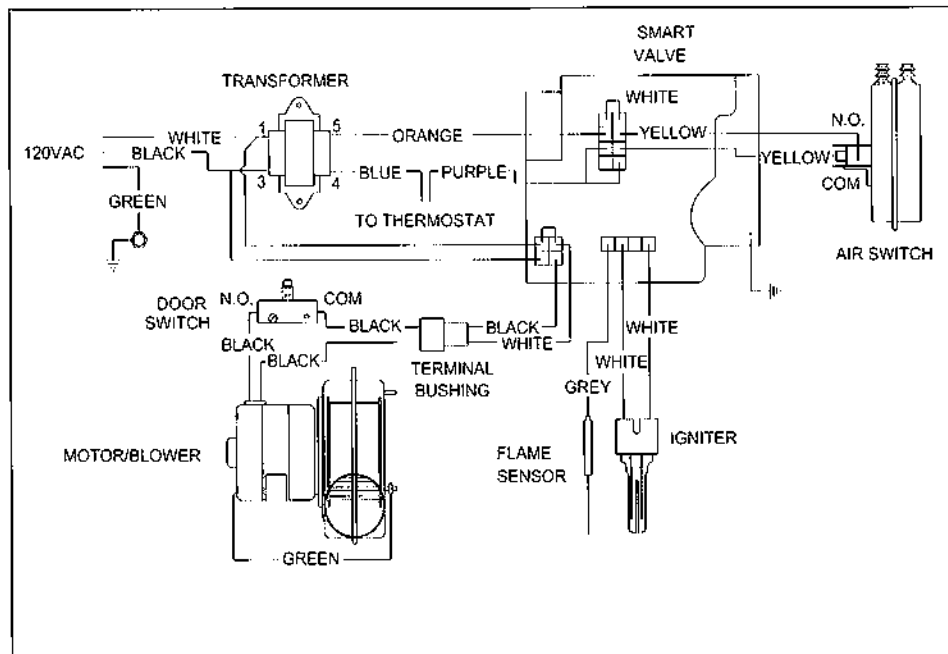



Figure 31. Burner Internal Wiring

► Section 11. Operation

⚠ WARNING

Fire Hazard
<p>Do not remove door when operating heater.</p> <p>No user serviceable parts inside.</p> <p>Failure to follow these instructions will result in death, injury or property damage.</p>
⚠ ATTENTION
Risque d'incendie
<p>Ne pas retirer porte lors du fonctionnement du radiateur.</p> <p>Ne contient aucune pièce révisable par l'utilisateur.</p> <p>Le non-respect de ces consignes peut causer mort, blessures ou dommage matériel.</p> <p style="text-align: right;"><small>© P/N 91037900</small></p>

The VANTAGE® II heater is equipped with a hot-surface ignition system.

Sequence of Operation

1. Turn the thermostat up. When the thermostat calls for heat, the SmartValve® II will energize. After a short period, power is supplied to the blower motor.
2. When the motor approaches nominal running RPM, the air proving switch closes and signals the ignition module/SmartValve® II.
3. The ignition module/SmartValve® II then energizes the hot surface igniter for a timed warm-up period (approximately 45 to 60 seconds).
4. After the warm-up period, the gas valve is energized.
5. The flame will be sensed by the flame sensing rod and the igniter is de-energized.
6. If a flame is detected, the gas valve remains open. When the call for heat is satisfied, and the system control mechanism de-energizes the burner line voltage supply, the gas valve is turned off.
7. If no flame is detected on the module, the gas valve is closed, and a purge period begins. After the purge, the module acts to power the igniter for a second warm up period, and a second trial for ignition period. If flame is still not established, a third purge, warm up, and trial cycle begins. After four trials, the module will lockout until reset. Reset is accomplished by removing power from the module for at least 5 seconds (thermostat cycle required).

⚠ WARNING
<p>Disconnect gas and electrical supplies before performing service or maintenance.</p> <p>Failure to follow these instructions will result in death, injury or property damage.</p>

Maintenance

For best performance, the following maintenance procedures should be performed before each heating season:

1. Be sure gas and electrical supply to heater are off before performing any service or maintenance.
2. Check condition of blower scroll and motor. Dirt and dust may be blown out with compressed air, or a vacuum cleaner may be used.
3. Check condition of burner. Carefully remove any dust or debris from inside the burner box or burner cup.
4. Inspect the igniter. Replace igniter if there is excessive carbon residue, erosion, breakage or other defects.
5. Check the inside of the firing tube with a flashlight. If carbon or scale are present remove the turbulator(s). Scrape out the deposits with a wire brush or rod, or metal plate attached to a wooden pole and replace turbulator(s) in tube.
6. Check to see that the burner observation window is clean and free of cracks or holes. Clean or replace as necessary.
7. Check the flue pipe for soot or dirt. After cleaning as necessary, re-attach the flue pipe to the heater.
8. Outside surfaces of heater reflector may be cleaned by wiping with a damp cloth.
9. A qualified service agency should be contacted for service other than routine maintenance.
10. Check vent terminal and fresh air inlet to see that they have not become blocked during the non-heating season. If either pipe is restricted, the air switch won't close, resulting in a no-heat situation.

► Section 12. Troubleshooting

⚠ WARNING

Disconnect gas and electrical supplies before performing service or maintenance.
Failure to follow these instructions will result in death, injury or property damage.

This heater is supplied with the Honeywell Smart Valve® II control system. This system is equipped with a diagnostic function that will assist in performing troubleshooting. The LED (Light Emitting Diode) indicator at the top of the Smart Valve® II control will flash in various patterns to indicate status. The LED status indication chart provided below gives a summary of possible faults.

LED STATUS INDICATES

Off	No power to the control.
Bright-Dim	Normal operation. This indication shows whenever the system is powered, unless some abnormal event has occurred.
2 Flashes	Airflow proving switch remains closed longer than 30 seconds after a call for heat begins (air proving switch stuck closed).
3 Flashes	Airflow proving switch remains open longer than 30 seconds after combustion air blower is energized.
5 Flashes	Flame signal sensed out of proper sequence.
6 Flashes	System Lockout.

⚠ WARNING



Electrical Shock Hazard

Do not disconnect ground leads inside heater.



Do not interchange grounded and ungrounded leads on transformer or ignition module.

Failure to follow these instructions will result in death or electrical shock.

Figure 32 on the next page will provide the information needed to test the manifold gas pressure setting. Figure 33 on pages 36 and 37 will take you through several troubleshooting steps to determine possible problems with the systems.

⚠ WARNING

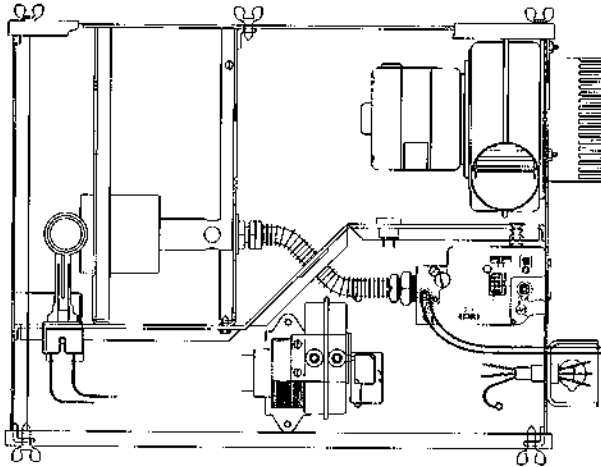
Electrical Shock Hazard
Disconnect electrical power before inserting meter into the circuit.
Replace door before operating.
Failure to follow these instructions will result in death or electrical shock.



Top View of Heater

Manometer

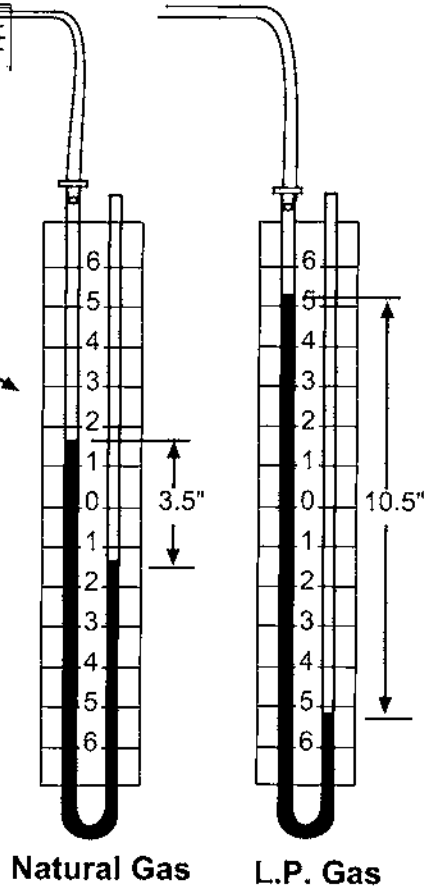
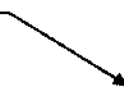

Figure 32. Manifold Gas Pressure Setting

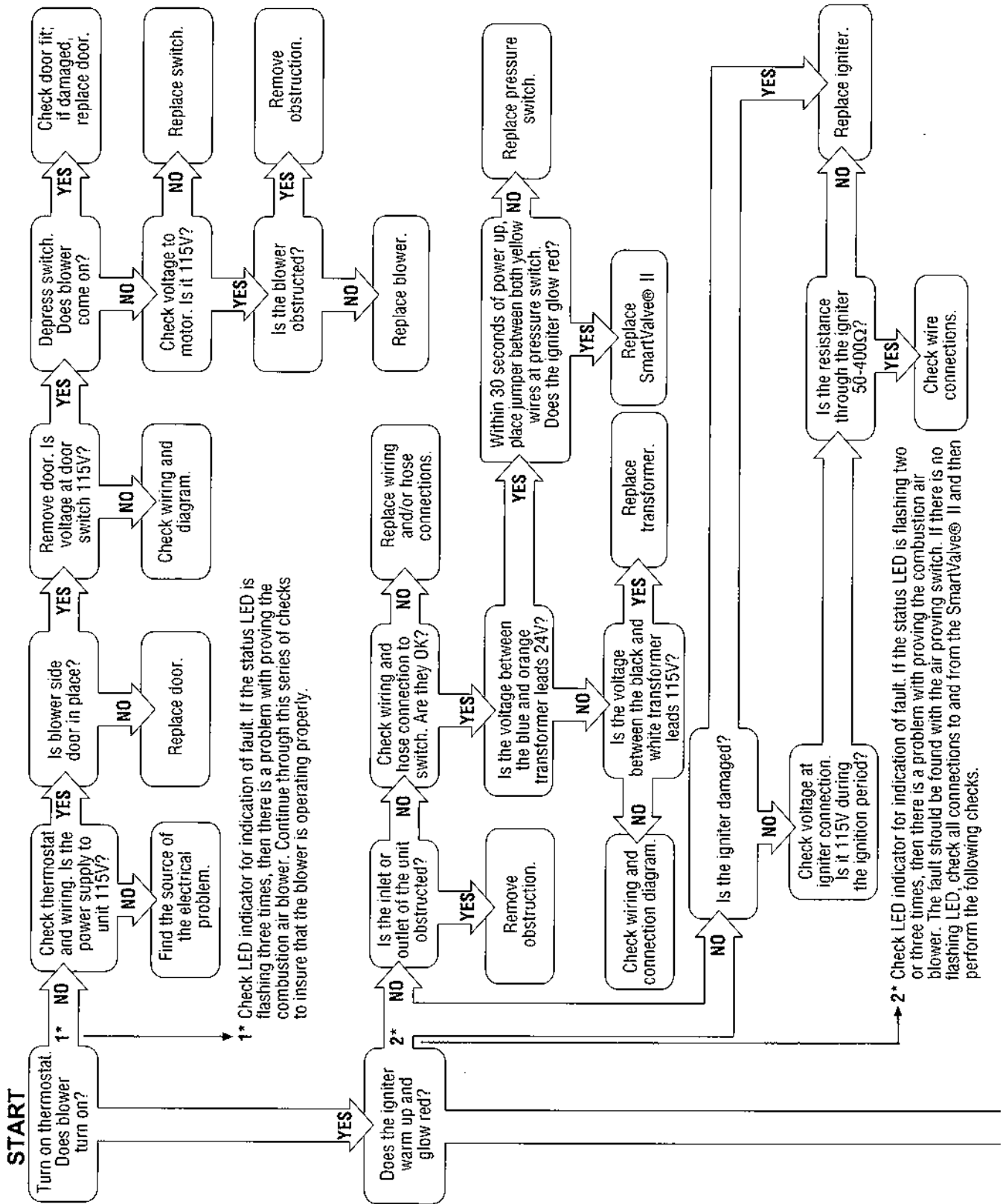

Figure 33. VANTAGE II® Troubleshooting Flow Chart

► Section 13. Replacement Parts

⚠ WARNING
Use only genuine Roberts-Gordon replacement parts.
Failure to follow these instructions will result in death, injury or property damage.

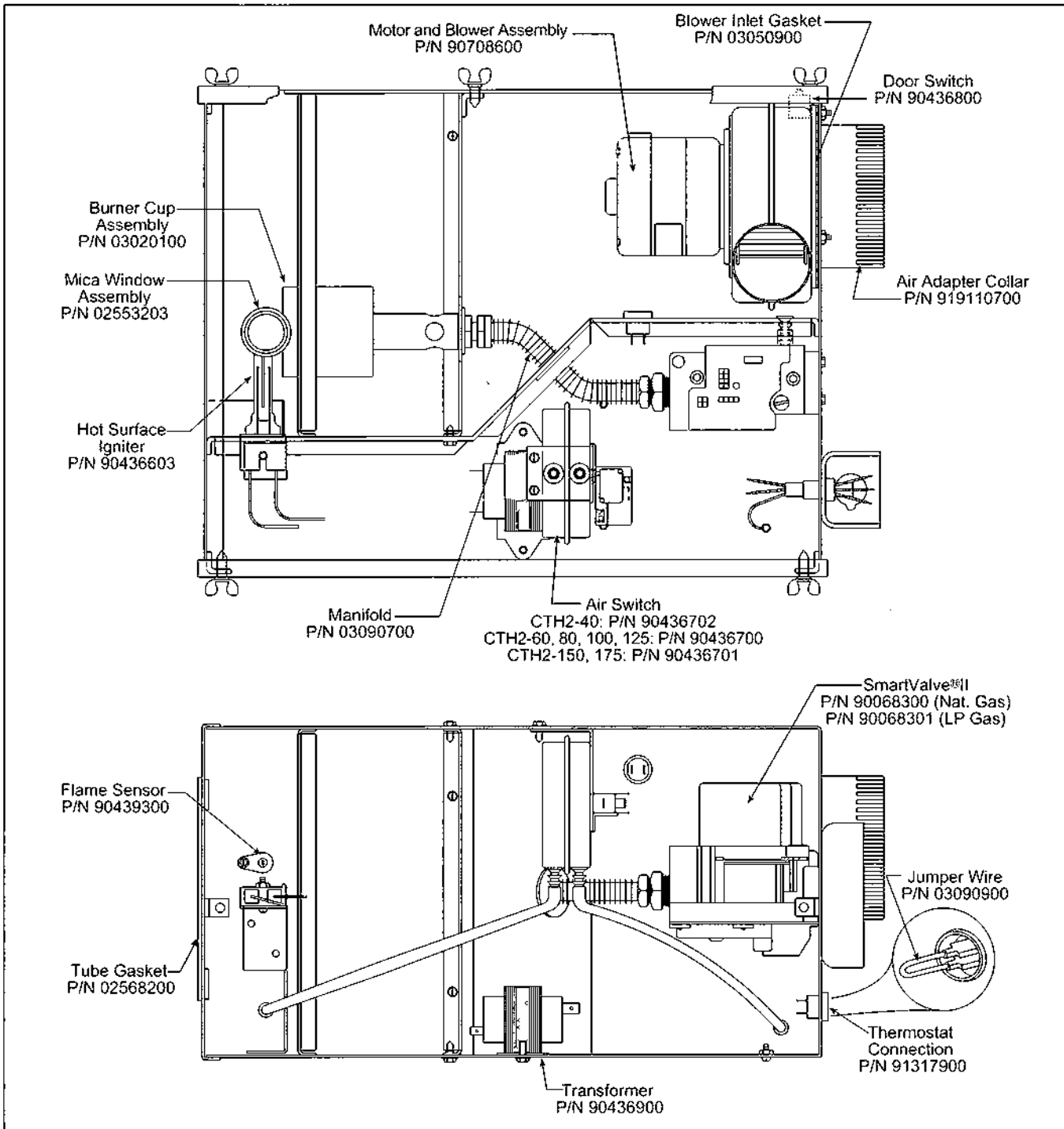

Figure 34. VANTAGE® II Series Burner Replacement Parts

► Section 14. Engineering Specifications

The total heating system supplied shall be design certified by the American Gas Association and the Canadian Gas Association.

A. Burner and Burner Controls

1. Burners shall be capable of firing with one of the fuel options as specified on the purchase documents: Natural Gas or LP.
2. Burners shall be supplied to fire at any one of the input firing rates as specified:

CTH2-40	40,000 BTU/Hr.
CTH2-60	60,000 BTU/Hr.
CTH2-80	80,000 BTU/Hr.
CTH2-100	100,000 BTU/Hr.
CTH2-125	125,000 BTU/Hr.
CTH2-150	150,000 BTU/Hr.
CTH2-175	175,000 BTU/Hr.
3. Burners shall be equipped with a system control that combines gas flow control and electronic burner ignition sequencing functions into a single unit. This control shall provide all gas ignition safety functions by controlling gas flow, ignition source and the combustion air blower. The control shall also monitor the air proving switch to assure proper burner operation. Such control shall provide prepurge and timed trial for ignition with multiple ignition trials and auto reset from lockout. This control shall contain an LED indicator to provide system status.
4. Power supplied to each burner shall be 120V, 60HZ, single phase. Burners shall be rated for 1.0 Amp (run) 5.0 Amp (start).
5. Burner shall be equipped with thermal overload motor protection, balanced air rotor, combustion air proving safety pressure switch, and viewing window for flame observation.
6. When specified, in contaminated environments, the burner shall be capable of supplying outside air to each burner for the support of combustion.
7. At customer's choice, burners may be controlled with either an optional line voltage thermostat or by optional low voltage thermostats.

8. Gas supply to the burners shall be as follows:

1/2" NPT (for CTH2-40, -60, -80, -100, & -125)

3/4"NPT (for CTH2-150 & -175)

Natural Gas: 4.6" W.C. MIN, 14.0" W.C. MAX
5.0" W.C. MIN for CTH2-175,

LP Gas: 11" W.C. MIN, 14.0" W.C. MAX

B. Heat Exchanger

1. Radiant tubing shall be 4" diameter, 16 gauge, aluminized steel first 10 feet, hot rolled steel remainder of unit (or when specified, all aluminized for entire radiant tube length). Sections shall be joined with stainless steel wrap-around couplings.
2. Reflector to be of aluminum material and designed to direct all radiant output below horizontal centerline of radiant tube. Reflectors shall be certified for 0° or 45° mounting.
3. Reflectors shall have end caps to prevent heat loss due to convection.
4. Steel turbulators to be used as specified for even heat distribution.
5. Heater to be vented according to manufacturer's instructions.

► Section 15. General Specifications

General Specifications for VANTAGE® II heaters are as follows:

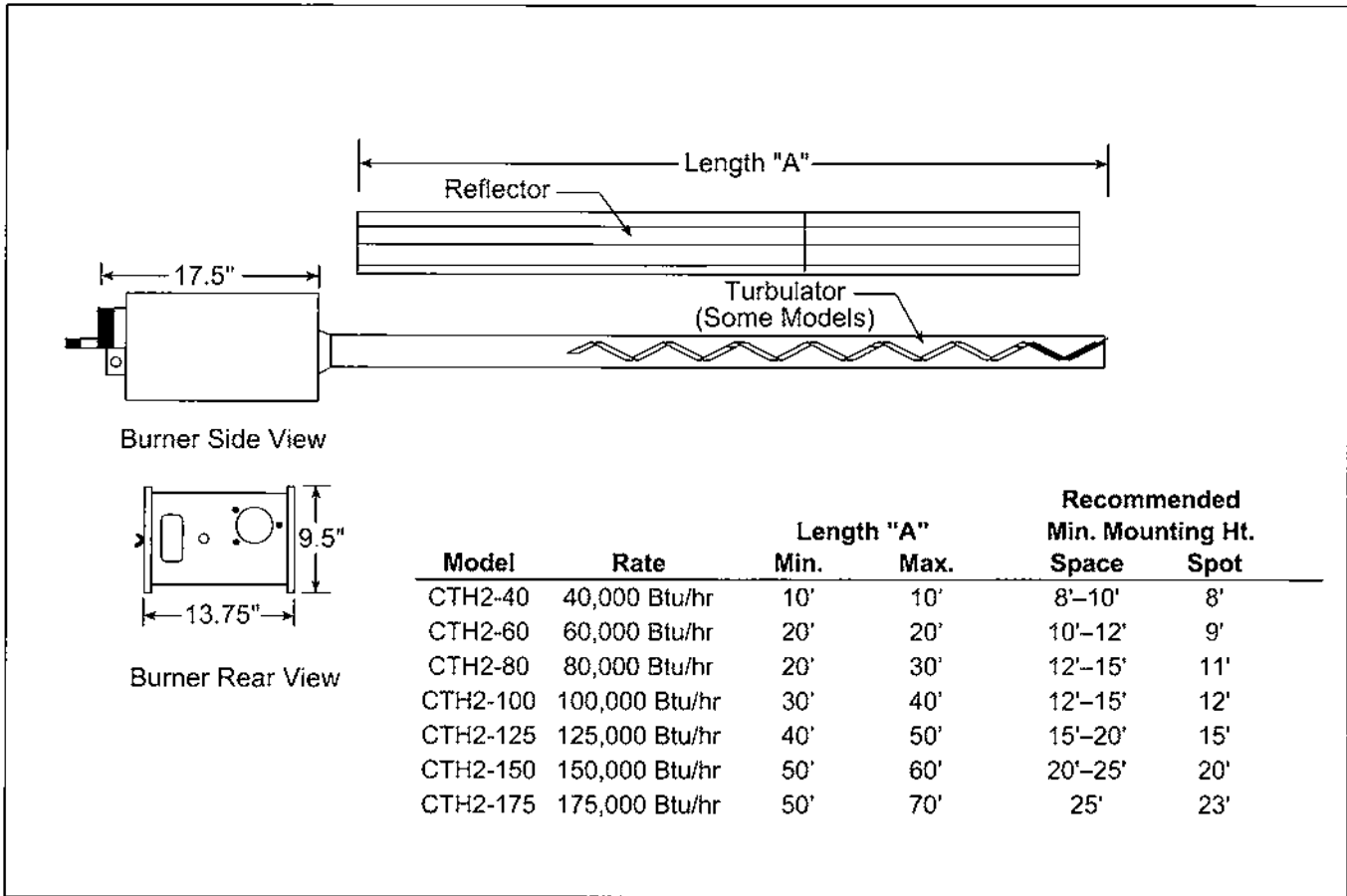

Figure 35. CTH2-Series Specifications

Gas Pressure at Manifold:

Natural Gas: 3.5" W.C.
 LP Gas: 10.5" W.C.

Pipe Connection:

1/2" NPT (for CTH2-40, -60, -80, -100, & -125)
 3/4" NPT (for CTH2-150 & -175)

Dimensions:

Vent Connection Size: 4" (10 cm)
 Outside Air Connection Size: 4" (10 cm)
 Refer to figure above for dimensional information.

Gas Inlet Pressure:

Natural Gas: 4.6" W.C. Minimum (for CTH2 40-60-80-100-125-150) 14.0" Maximum
 5.0" W.C. Minimum (for CTH2-175) 14.0" Maximum

LP Gas: 11.0" W.C. Minimum 14.0" Maximum

Electrical Rating: (All Models)

120V- 60 Hz., 1.0 Amp (run) 5.0 Amp (start)

► Section 16. VANTAGE® II Limited Warranty

WARRANTY COVERAGE:

Roberts-Gordon, Inc. ("Seller") warrants that entire heating systems sold by it (individually a "System") and any replacement parts which it sells relating to any System ("Parts") shall be free from defects in workmanship and material for the time periods described as follows. With respect to a System this warranty shall apply for a period of three years from delivery to the original purchaser ("Buyer"). With respect to Parts, this warranty shall apply for the longer of the original System warranty period or for a period of one year. ("Systems" and "Parts" are hereinafter collectively referred to as "Products".) This warranty extends only to the original purchaser of Products.

Seller manufactures products which are designed only to provide predetermined ranges of heat rises in various enclosures when properly used in systems designed by purchaser or others and installed by others. Seller makes no representation or warranty with respect to the effect upon enclosure, or upon any of the contents of the enclosure, including, without limitation, all plant or animal life, kept or processed in the enclosure subject to the limitations outlined below.

WARNING:

This warranty is void if the products have been damaged due to accident, abuse, mishandling or any other cause whatsoever other than defects in material or workmanship. Specifically, Seller's warranty shall not apply: (a) to damage to Products when used in an atmosphere containing halogenated hydrocarbons or other corrosive chemicals. Some compounds in the air can be ingested into the equipment and can cause an accelerated rate of corrosion of some of the Products. The use of such chemical compounds in or near the enclosure should be avoided where a longer life of the burner, tubing and other parts is desirable; (b) to Products which have been repaired or replaced with other than factory parts, modified in any way, misused or damaged, or which have been installed or used contrary to Seller's written instructions or manuals; or (c) to any damage resulting from improper service or a lack of proper maintenance.

LIMITATIONS OF WARRANTY:

Other than as stated herein or in any other warranty of Seller, there are no other warranties of any kind whatsoever, express or implied, and all other express and all implied warranties of merchantability and/or fitness for any particular purpose are hereby specifically disclaimed.

EXCLUSIVE REMEDY:

The sole and exclusive remedy for any loss, damage or liability, or otherwise, is limited to the obligation of Seller to repair or replace parts, at its factory, of any product owned by original buyer and returned to the Seller's factory within one year after invoice, with transportation charges prepaid, which examination reveals to have been defective. Under no circumstances shall Seller be liable for any loss, damage, cost, expenses, or incidental or consequential damages of any kind, in connection with the sale, installation, use, maintenance, or repair of any Product.

BUYER RESPONSIBLE FOR DATA:

Seller and its representative may furnish Buyer, upon Buyer's request, data relating to the function and use of Products. Seller shall not be liable for loss, damage, cost, expenses or incidental or consequential damages of any kind, sustained directly or indirectly, by any person, or to any property, if Buyer adopts and uses such data in whole or in part.

LIMITATIONS ON AUTHORITY OF REPRESENTATIVES:

No representative of Seller, other than an Executive Officer, has authority to change or extend these provisions. Changes or extension shall be binding only if confirmed in writing by Seller's duly authorized Executive Officer.

Direct any question or warranty claims to the original installer:

Company: _____
Address: _____

Phone: _____

Or to: Warranty Claims
Roberts-Gordon, Inc.
1250 William Street
P.O. Box 44
Buffalo, NY 14240-0044

Warranty Claims
Roberts-Gordon Canada Inc.
241 South Service Road West
Grimsby, Ontario L3M-1Y7

