

Blackheat™ NP1

Negative Pressure Unitary or Multiburner Infrared Heater

Installation, Operation & Service Manual

CTHN-40
CTHN-60
CTHN-80
CTHN-100
CTHN-125
CTHN-150
CTHN-175
CTHN-200



FOR YOUR SAFETY

If you smell gas:

1. Open windows.
2. **DO NOT** try to light any appliance.
3. **DO NOT** use electrical switches.
4. **DO NOT** use any telephone in your building.
5. Extinguish any open flame.
6. Leave the building.
7. Immediately call your local gas supplier after leaving the building. Follow the gas supplier's instructions.
8. If you cannot reach your gas supplier, call the Fire Department.

⚠ WARNING



Fire Hazard

Keep all flammable objects, liquids and vapors the minimum required clearances to combustibles away from heater.

Some objects will catch fire or explode when placed close to heater.

Failure to follow these instructions can result in death, injury or property damage.

⚠ WARNING

Improper installation, adjustment, alteration, service or maintenance can result in death, injury or property damage. Read the Installation, Operation and Service Manual thoroughly before installing or servicing this equipment.

Installation must be done by a contractor qualified in the installation and service of gas-fired heating equipment or your gas supplier.

Installer

Please take the time to read and understand these instructions prior to any installation. Installer must give a copy of this manual to the owner.

Owner

Keep this manual in a safe place in order to provide your serviceman with necessary information.



Roberts-Gordon LLC

1250 William Street
P.O. Box 44
Buffalo, New York 14240-0044
Telephone: +1.716.852.4400
Fax: +1.716.852.0854
Toll Free: 800.828.7450

www.rg-inc.com
www.radiantheaters.com

TABLE OF CONTENTS

SECTION 1: Heater Safety	1	12.2 Unvented Operation Termination.....	54
1.1 Manpower Requirements.....	1	12.3 Horizontal Venting.....	54
1.2 Safety Labels and Their Placement.....	1	12.4 Vertical Venting.....	54
1.3 California Proposition 65.....	1	12.5 Length Requirements.....	54
SECTION 2: Installer Responsibility	4	12.6 Flue Connection Detail.....	55
2.1 Wall Tag.....	4	12.7 Horizontal Ventilation 4" (10 cm) Pipe.....	55
2.2 Corrosive Chemicals.....	4	12.8 Vertical Ventilation 4" (10 cm) Pipe.....	56
2.3 National Standards and Applicable Codes.....	4	12.9 Common Side Wall Venting.....	56
SECTION 3: Critical Considerations	5	12.10 Common Vertical Venting.....	57
3.1 Required Clearances to Combustibles.....	5	SECTION 13: Venting - Multiburner Systems	58
SECTION 4: National Standards and Applicable Codes	9	13.1 General Requirements.....	58
4.1 Gas Codes.....	9	13.2 Manifold Tube Requirements.....	58
4.2 Aircraft Hangars.....	9	13.3 Venting the Pump.....	58
4.3 Public Garages.....	9	13.4 EP-100 Pump Models.....	59
4.4 Electrical.....	9	13.5 EP-200 Pump Series.....	59
4.5 Venting.....	9	13.6 EP-300 Pump Series.....	59
4.6 High Altitude.....	9	13.7 Installation Precautions.....	59
SECTION 5: Heater Descriptions	10	SECTION 14: Outside Combustion Air Supply	61
5.1 Unitary vs. Multiburner.....	10	14.1 Length Requirements.....	61
SECTION 6: Major Components	11	14.2 Vertical Non-Pressurized Outside Air Supply for Single Heater Installation.....	61
SECTION 7: General Suspension Details	12	14.3 Horizontal Non-Pressurized Outside Air Supply for Single Heater Installation.....	61
SECTION 8: Unitary Linear & U-Tube Heater Installation..	14	14.4 Vertical Non-Pressurized Outside Air Supply for Double Heater Installation.....	62
8.1 Standard Parts.....	14	14.5 Horizontal Non-Pressurized Outside Air Supply for Double Heater Installation.....	62
8.2 Unitary Heater Requirements.....	17	14.6 Pressurized Outside Air Supply.....	63
8.3 Unitary Linear Heater Layouts.....	18	14.7 Outside Air Blower Internal Wiring.....	63
8.4 Unitary U-tube Heater Layouts.....	21	SECTION 15: Wiring	64
8.5 Burner Tube Installation.....	23	15.1 Internal Wiring.....	64
8.6 Tube Clamp Package Installation.....	23	15.2 Internal Wiring.....	64
8.7 Coupling and Tube Assembly.....	24	15.3 Ladder Diagram.....	65
8.8 Turbulator Installation.....	25	15.4 External Wiring (Unitary Heaters Only).....	65
8.9 Reflector Installation.....	26	15.5 Line Voltage Thermostat Wiring (Unitary Heaters Only).....	66
8.10 Burner Installation.....	28	15.6 Low Voltage Thermostat Wiring (Unitary Heaters Only).....	66
8.11 Fan Inlet Plate and Warning Tag.....	28	15.7 System Control Methods and External Multiburner Wiring.....	67
8.12 Restrictor Plate Installation.....	29	SECTION 16: Gas Piping	70
8.13 Fan Installation.....	29	SECTION 17: Operation and Maintenance	72
SECTION 9: Multiburner Heater Installation	30	17.1 Checking the Gas Line.....	72
9.1 Standard Parts.....	30	17.2 Unitary Heater Sequence of Operation.....	72
9.2 Multiburner System Design Requirements.....	33	17.3 Multiburner System Operation.....	73
9.3 Burners Per Pump.....	34	17.4 Maintenance.....	75
9.4 Radiant Tube Length.....	35	17.5 Maintenance Checklist.....	75
9.5 Manifold Tube.....	35	SECTION 18: Troubleshooting	77
9.6 Multiburner System Layouts and Manifold Tube Length Rules.....	35	18.1 Troubleshooting Flow Chart - Unitary.....	78
9.7 Burner Tube Installation.....	40	18.2 Troubleshooting Flow Chart - Multiburner.....	82
9.8 Tube Clamp Package Installation.....	40	18.3 Manifold Gas Pressure Setting.....	84
9.9 Coupling and Tube Assembly.....	41	SECTION 19: Replacement Parts List	85
9.10 Turbulator Installation.....	42	SECTION 20: General Specifications	88
9.11 Reflector Installation.....	43	20.1 Material Specifications.....	88
9.12 Burner Installation.....	45	20.2 Heater Specifications.....	88
SECTION 10: Optional Heater Accessories	46	20.3 Suspension Specifications.....	88
10.1 Elbow Package Configuration.....	46	20.4 Controls Specifications.....	88
10.2 Reflector Side Extension.....	48	SECTION 21: The ROBERTS GORDON® BLACKHEAT™ NP Limited Warranty	91
10.3 Lower Clearance Shield Installation.....	49		
10.4 Two-Foot Decorative Grille Installation.....	50		
10.5 Protective Grille Installation.....	52		
SECTION 11: Venting - General	53		
11.1 General Venting Requirements.....	53		
SECTION 12: Venting - Unitary Heater	54		
12.1 Unvented Operation.....	54		

© 2012 Roberts-Gordon LLC

All rights reserved. No part of this work covered by the copyrights herein may be reproduced or copied in any form or by any means - graphic, electronic, or mechanical, including photocopying, recording, taping or information storage and retrieval systems - without the written permission of Roberts-Gordon LLC.

TABLE OF FIGURES

Figure 1: Top and Bottom Panel Label Placement	2
Figure 2: Side and Back Panel Label Placement	3
Figure 3: Standard Reflector	5
Figure 4: One Side Reflector	6
Figure 5: Two Side Reflectors	6
Figure 6: 45° Tilt Reflector	6
Figure 7: U-Tube, Standard Reflector	7
Figure 8: U-Tube, 45°	7
Figure 9: U-Tube, Opposite 45° Reflector	7
Figure 10: 2-Foot Deco Grille and Protective Grille	8
Figure 11: Lower Clearance Shield	8
Figure 12: Venting	8
Figure 13: Major Component Descriptions	11
Figure 14: Critical Hanger Placement	13
Figure 15: Linear Heater Assembly Overview	18
Figure 16: Unitary Linear Layout Overview	19
Figure 17: Unitary Linear Layout Overview (Continued)	20
Figure 18: U-tube Assembly Overview	21
Figure 19: Unitary U-tube Layout Overview	22
Figure 20: Typical CTHN Multiburner System Installation	33
Figure 21: Flag Layout	36
Figure 22: Modified In-Series Layout	36
Figure 23: T Layout	37
Figure 24: Fork Layout	38
Figure 25: Herringbone Layout	39
Figure 26: Reflector Joint Detail	48
Figure 27: Fan Termination	54
Figure 28: Tailpipe Connection Points	58
Figure 29: Roof Venting of Pump	59
Figure 30: Side Wall Venting Configurations	60
Figure 31: Outside Air Blower Internal Wiring Diagram	63
Figure 32: One Zone Operation without Control Panel (Multiburner)	68
Figure 33: Two Zone Operation without Control Panel (Multiburner)	69
Figure 34: Gas Connection with Flexible Gas Hose	71
Figure 35: Vacuum Differential Reading	74

LIST OF TABLES

Table 1: Contents of CTHN Burner Carton	14
Table 2: Contents of Core and Extension Packages	15
Table 3: Component Package Guide	15
Table 4: Common CTHN-Series Components	16
Table 5: Unitary Heater Design Requirements	17
Table 6: Contents of CTHN Burner Carton	30
Table 7: Contents of Core and Extension Packages	31
Table 8: Component Package Guide	31
Table 9: Common CTHN-Series Components	32
Table 10: Multiburner Design Requirements	34
Table 11: Number of Burners Allowed Per Pump	34

SECTION 1: HEATER SAFETY



Your Safety is Important to Us! This symbol is used throughout the manual to notify you of possible fire, electrical or burn hazards. Please pay special attention when reading and following the warnings in these sections.

Installation, service and annual inspection of heater must be done by a contractor qualified in the installation and service of gas-fired heating equipment.

Read this manual carefully before installation, operation or service of this equipment.

This heater is designed for heating nonresidential indoor spaces. Do not install in residential spaces. These instructions, the layout drawing, local codes and ordinances, and applicable standards that apply to gas piping, electrical wiring, venting, etc. must be thoroughly understood before proceeding with the installation.

Protective gear is to be worn during installation, operation and service. Thin sheet metal parts, including the aluminum reflector and the various venting components, have sharp edges. To prevent injury, the use of work

gloves is recommended. The use of gloves will also prevent the transfer of body oils from the hands to the surface of the reflector.

Before installation, check that the local distribution conditions, nature of gas and pressure, and adjustment of the appliance are compatible.

This heater must be applied and operated under the general concepts of reasonable use and installed using best building practices.

This appliance is not intended for use by persons (including children) with reduced physical, sensory or mental capabilities, or lack of experience and knowledge, unless they have been given supervision or instruction concerning use of the appliance by a person responsible for their safety. Children should be supervised to ensure that they do not play with the appliance.

For additional copies of the Installation, Operation and Service Manual, please contact Roberts-Gordon LLC.

1.1 Manpower Requirements

To prevent personal injury and damage to the heater, two persons will be required for installation.

1.2 Safety Labels and Their Placement

Product safety signs or labels should be replaced by the product user when they are no longer legible. Please contact Roberts-Gordon or your ROBERTS GORDON® independent distributor to obtain replacement signs or labels. See *Page 2, Figure 1 through Page 3, Figure 2*.

1.3 California Proposition 65

In accordance with California Proposition 65 requirements, a warning label must be placed in a highly visible location on the outside of the equipment (i.e., near equipment's serial plate). See label placement drawing on *Page 2, Figure 1 through Page 3, Figure 2* for label location. Avoid placing label on areas with extreme heat, cold, corrosive chemicals or other elements. To order additional labels, please contact Roberts-Gordon LLC or your ROBERTS GORDON® independent distributor.

FIGURE 1: Top and Bottom Panel Label Placement

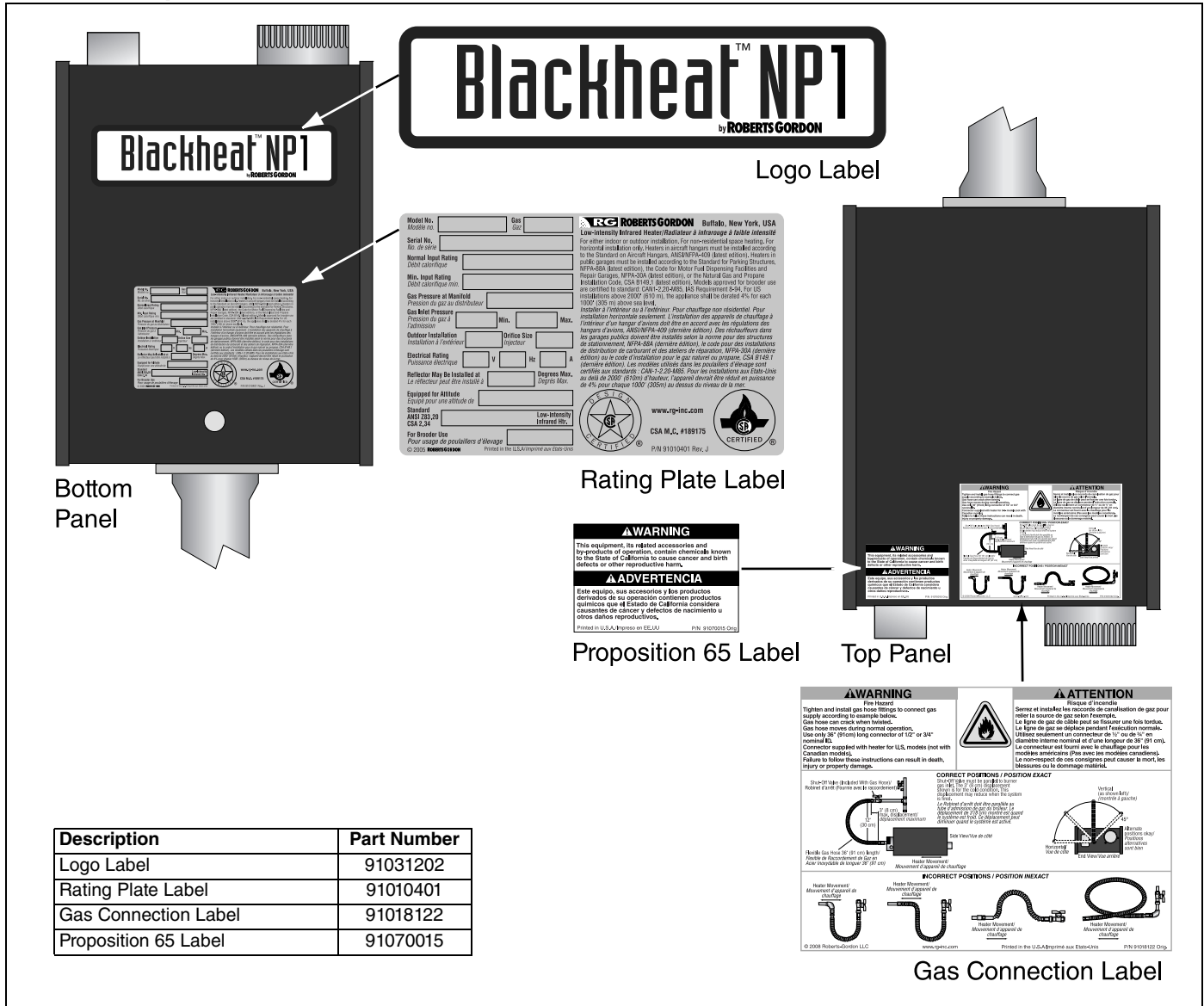

Logo Label



Rating Plate Label



Proposition 65 Label

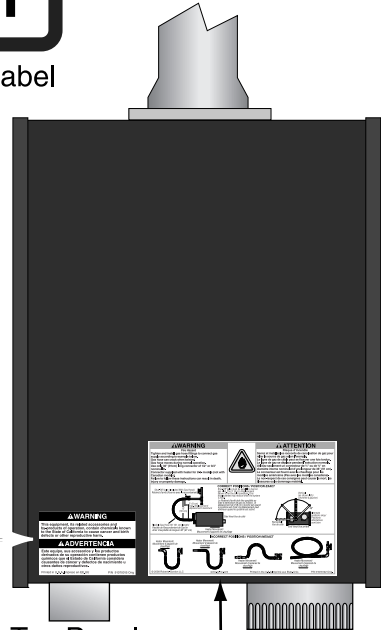

Top Panel

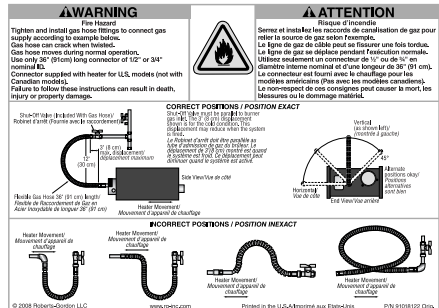

Gas Connection Label

FIGURE 2: Side and Back Panel Label Placement

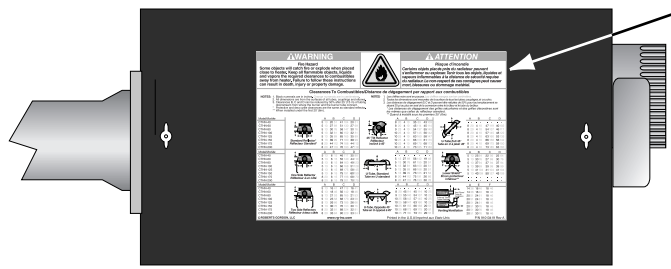

Control Side Panel

⚠ WARNING

Fire Hazard

Some objects will catch fire or explode when placed close to heater. Keep all flammable objects, liquids and vapors the required clearances to combustibles away from heater. Failure to follow these instructions can result in death, injury or property damage.

⚠ ATTENTION

Risque d'incendie

Certains objets placés près du radiateur peuvent s'enflammer ou exploser. Tenir tous les objets, liquides et vapeurs inflammables à la distance de sécurité requise du radiateur. Le non-respect de ces consignes peut causer mort, blessures ou dommages matériels.

Clearances to Combustibles / Distance de dégagement par rapport aux combustibles

NOTES:

- All dimensions are in inches. (Toutes les mesures sont en pouces.)
- All dimensions are from the surface of all tubes, couplings and elbows. (Toutes les dimensions sont mesurées de la surface de tous les tubes, raccords et coudes.)
- Clearances to U-Tube can be reduced by 20% after 20" of tubing. (Les distances de dégagement à U-Tube peuvent être réduites de 20% pour une installation de plus de 20" de tube en U.)
- Reflective and duct grille clearances are the same as standard reflector. (Les distances de dégagement des grilles réfléchissantes et des grilles décoratives sont les mêmes que celles du réflecteur standard.)
- When installed under the last 20" (5m).
- Quand à installer sous les premiers 20" (5m).

Model/Modèle	A	B	C	D	E	F
CTHN-40	5 1/2	20 1/4	41 1/8	20 1/4	8 1/2	4 1/4
CTHN-60	5 1/2	27 5/8	51 1/8	27 5/8	8 3/8	4 1/8
CTHN-80	5 1/2	32 1/8	60 1/8	32 1/8	9 1/8	4 1/8
CTHN-100	5 1/2	32 1/8	60 1/8	32 1/8	10 1/8	4 1/8
CTHN-125	5 1/2	35 3/8	65 1/8	35 3/8	10 3/8	4 1/8
CTHN-150	5 1/2	39 1/8	71 1/8	39 1/8	10 3/8	4 1/8
CTHN-175	8 20	44 1/8	78 1/8	44 1/8	10 3/8	4 1/8
CTHN-200	8 20	47 1/8	78 1/8	47 1/8	10 3/8	4 1/8

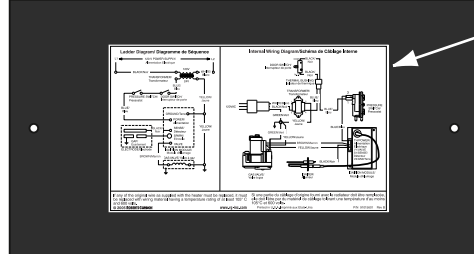

Control Side Panel (Inside)

Ladder Diagram / Diagramme de Séquence

Internal Wiring Diagram / Schéma de Câblage Interne

Clearances to Combustibles Label

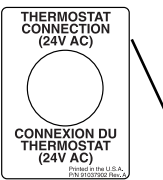

Thermostat Connection Label

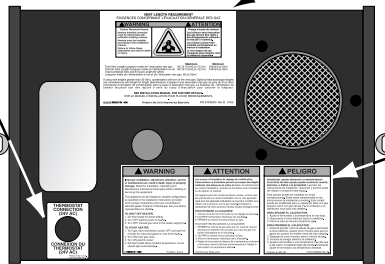

Back Panel

VENT LENGTH REQUIREMENT / EXIGENCES CONCERNANT L'ÉLEVATION GÉNÉRALE DES GAZ

⚠ WARNING

Correct venting is essential for safe operation. Improper venting can result in death, injury or property damage. Read the installation, operating and maintenance instructions thoroughly before installing or servicing the equipment.

⚠ ATTENTION

Les brûleurs sans ventilation sont dangereux. Une mauvaise ventilation peut entraîner la mort, des blessures ou des dommages matériels. Lire attentivement les instructions relatives à l'installation, à l'exploitation et à l'entretien avant d'installer ou de servir l'équipement.

Minimum	Maximum
45 (1158.8 mm) (6 ft) (1829 mm)	45 (1158.8 mm) (6 ft) (1829 mm)
15 (381 mm) (5 ft) (1524 mm)	15 (381 mm) (5 ft) (1524 mm)

SEE INSTALLATION MANUAL FOR FURTHER DETAILS. / VOIR LE MANUEL D'INSTALLATION POUR PLUS DE RENSEIGNEMENTS.

⚠ WARNING

Proper installation, adjustment, alteration, service or maintenance can result in death, injury or property damage. Read the installation, operating and maintenance instructions thoroughly before installing or servicing the equipment.

⚠ ATTENTION

Les erreurs d'installation de réglage de modification, d'entretien ou d'entretien peuvent provoquer des décès, des blessures, des dommages matériels. Lire attentivement les instructions relatives à l'installation, à l'exploitation et à l'entretien avant d'installer ou de servir l'équipement.

⚠ PELIGRO

Instalación, ajuste alteración o mantenimiento incorrecto de este equipo puede ocasionar muerte, lesiones, o daños a la propiedad. Lea atentamente las instrucciones de instalación, operación y servicio antes de instalar o componer este equipo.

TO START HEATER:

- Set thermostat to lowest setting.
- Turn OFF electric power to heater.
- Turn OFF manual gas valve in the heater supply line.

TO STOP HEATER:

- Turn gas valve and electric power OFF and wait five minutes for unburned gases to vent from heater.
- Turn OFF main gas valve.
- Turn OFF electric power.
- Set thermostat above ambient temperature, burner should ignite automatically.

Description	Part Number
Clearances to Combustibles Label	91013419
Wiring Label	91015601
Vent Length Label	91039500
Thermostat Connection Label	91037902
Lighting Instruction Plate Label	91029602

SECTION 2: INSTALLER RESPONSIBILITY

The installer is responsible for the following:

- To install the heater, as well as the gas and electrical supplies, in accordance with applicable specifications and codes. Roberts-Gordon recommends the installer contact a local Building Inspector or Fire Marshal for guidance.
- To use the information given in a layout drawing and in the manual together with the cited codes and regulations to perform the installation.
- To install the heater in accordance with the clearances to combustibles requirements.
- To furnish all needed materials not furnished as standard equipment.
- To plan location of supports.
- To provide access to burners on all sides for burner servicing and removal.
- To provide the owner with a copy of this Installation, Operation and Service Manual.
- To never use heater as a support for a ladder or other access equipment and never hang or suspend anything from heater.
- To ensure there is adequate air circulation around the heater and to supply air for combustion, ventilation and distribution in accordance with local codes.
- To safely and adequately install heater using materials with a minimal working load of 75 lbs (33 kg).
- To ensure the heater is placed in an approved application.

2.1 Wall Tag

A laminated wall tag is available for the heater as a permanent reminder of the safety instructions and the importance of the required clearances to combustibles. Please contact Roberts-Gordon or your ROBERTS GORDON® independent distributor to obtain the wall tag. Affix the tag by peeling off the backing of the adhesive strips on the rear surface and position the tag on a wall near the heater (e.g. thermostat or ROBERTS GORDON® Controller).

A copy of the wall tag (P/N 91037912) is illustrated on the back cover. For an immediate solution, you may affix this copy on the wall near the heater.

Know your model number and installed configuration. Model number and installed configuration are found on the burner and in the Installation, Operation and Service Manual. See Page 5, Figure 3 through Page 8, Figure 12. Write the proper clearance dimensions in permanent ink according to your model number and configuration in the open spaces on the tag.

2.2 Corrosive Chemicals

<p>Product Damage Hazard</p> <p>Do not use heater in area containing corrosive chemicals.</p> <p>Refer to appropriate Material Safety Data Sheets (MSDS).</p> <p>Failure to follow these instructions can result in product damage.</p>

Roberts-Gordon cannot be responsible for ensuring that all appropriate safety measures are undertaken prior to installation; this is entirely the responsibility of the installer. It is essential that the contractor, the sub-contractor, or the owner identifies the presence of combustible materials, corrosive chemicals or halogenated hydrocarbons* anywhere in the premises.

** **Halogenated Hydrocarbons** are a family of chemical compounds characterized by the presence of halogen elements (fluorine, chlorine, bromine, etc.). These compounds are frequently used in refrigerants, cleaning agents, solvents, etc. If these compounds enter the air supply of the burner, the life span of the heater components will be greatly reduced. An outside air supply must be provided to the burners whenever the presence of these compounds is suspected. Warranty will be invalid if the heater is exposed to halogenated hydrocarbons.*

2.3 National Standards and Applicable Codes

All appliances must be installed in accordance with the latest revision of the applicable standards and national codes. This refers also to the electric, gas and venting installation. Note: Additional standards for installations in public garages, aircraft hangars, etc. may be applicable.

SECTION 3: CRITICAL CONSIDERATIONS

3.1 Required Clearances to Combustibles

Clearances are the required distances that combustible objects must be away from the heater to prevent fire hazards. Combustible materials that may catch fire include common items such as wood, paper, rubber, fabric, etc. **Maintain clearances to combustibles at all times for safety.**

Clearances for all heater models are located on the burner of the heater and *on Page 5, Figure 3 through Page 8, Figure 12* in this manual. Check the clearances on each burner for the model heater being installed to make sure the product is suitable for your application and the clearances are maintained. Read and follow the safety guidelines below:

- Keep gasoline or other combustible materials including flammable objects, liquids, dust or vapors away from this heater or any other appliance.
- The stated clearances to combustibles represents a surface temperature of 90° F (50° C) above room temperature. Building materials with a low heat tolerance (such as plastics, vinyl siding, canvas, tri-ply, etc) may be subject to degradation at lower temperatures. It is the installer's responsibility to assure that adjacent materials are protected from degradation.
- Maintain clearances from heat sensitive material, equipment and workstations.
- Maintain clearances from vehicles parked below the heater.
- Maintain clearances from swinging and overhead doors, overhead cranes, vehicle lifts, partitions, storage racks, hoists, building construction, etc.
- In locations used for the storage of combustible materials, signs must be posted to specify the

! WARNING



Fire Hazard

Keep all flammable objects, liquids and vapors the minimum required clearances to combustibles away from heater.

Some objects will catch fire or explode when placed close to heater.

Failure to follow these instructions can result in death, injury or property damage.

maximum permissible stacking height to maintain required clearances from the heater to the combustibles. Signs must be posted adjacent to the heater thermostat. In the absence of a thermostat, signs must be posted in a conspicuous location.

- Consult local Fire Marshal, Fire Insurance Carrier or other authorities for approval of proposed installation when there is a possibility of exposure to combustible airborne materials or vapors.
- Hang heater in accordance to the minimum suspension requirements *on Page 13, Figure 14*.
- If the radiant tubes must pass through the building structure, be sure that adequate sleeving and fire stop is installed to prevent scorching and/or fire hazard.

- NOTE:** 1. All dimensions are from the surfaces of all tubes, couplings and elbows.
2. Clearances B, C and D can be reduced by 50% after 25' (7.5 m) of tubing downstream from where the burner and burner tube connect.

FIGURE 3: STANDARD REFLECTOR

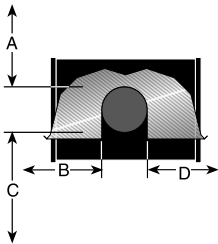
	Model	(inches)				(centimeters)			
		A	B	C	D	A	B	C	D
	CTHN-40	5	20	41	20	13	51	104	51
	CTHN-60	5	27	51	27	13	69	130	69
	CTHN-80	5	30	58	30	13	76	147	76
	CTHN-100	5	32	60	32	13	81	152	81
	CTHN-125	5	35	65	35	13	89	165	89
	CTHN-150	5	39	71	39	13	99	180	99
	CTHN-175	8	44	74	44	20	112	188	112
	CTHN-200	8	47	76	47	20	119	193	119

NOTE: 1. All dimensions are from the surfaces of all tubes, couplings and elbows.
 2. Clearances B, C and D can be reduced by 50% after 25' (7.5 m) of tubing downstream from where the burner and burner tube connect.

FIGURE 4: ONE SIDE REFLECTOR

	Model	(inches)				(centimeters)			
		A	B	C	D	A	B	C	D
	CTHN-40	5	6	46	35	13	15	117	88
	CTHN-60	5	6	55	44	13	15	140	110
	CTHN-80	5	6	64	49	13	15	163	123
	CTHN-100	5	6	66	51	13	15	168	128
	CTHN-125	5	6	69	58	13	15	175	145
	CTHN-150	5	6	75	60	13	15	191	150
	CTHN-175	8	6	77	68	20	15	196	170
	CTHN-200	8	6	79	70	20	15	201	175

FIGURE 5: TWO SIDE REFLECTORS

	Model	(inches)				(centimeters)			
		A	B	C	D	A	B	C	D
	CTHN-40	5	16	47	16	13	41	119	41
	CTHN-60	5	18	56	18	13	46	142	46
	CTHN-80	5	21	65	21	13	53	165	53
	CTHN-100	5	23	68	23	13	58	173	58
	CTHN-125	5	26	73	26	13	66	185	66
	CTHN-150	5	30	76	30	13	76	193	76
	CTHN-175	8	32	88	32	20	81	224	81
	CTHN-200	8	33	90	33	20	84	229	84

FIGURE 6: 45° TILT REFLECTOR

	Model	(inches)				(centimeters)			
		A	B	C	D	A	B	C	D
	CTHN-40	8	4	35	43	20	10	89	109
	CTHN-60	8	4	45	45	20	10	114	114
	CTHN-80	9	4	54	55	23	10	137	140
	CTHN-100	10	4	57	56	25	10	145	142
	CTHN-125	10	4	63	58	25	10	160	147
	CTHN-150	10	4	66	61	25	10	168	155
	CTHN-175	10	4	69	68	25	10	175	173
	CTHN-200	10	4	73	71	25	10	185	180

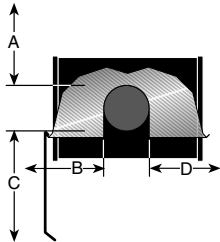
- NOTE:** 1. All dimensions are from the surfaces of all tubes, couplings and elbows.
 2. Clearances B, C and D can be reduced by 50% after 25' (7.5 m) of tubing downstream from where the burner and burner tube connect.

FIGURE 7: U-TUBE, STANDARD REFLECTOR

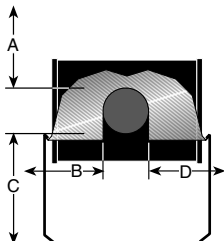
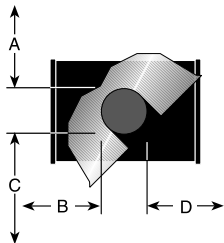
	Model	(inches)				(centimeters)			
		A	B	C	D	A	B	C	D
	CTHN-40	- UNAPPROVED -				- UNAPPROVED -			
	CTHN-60	5	27	56	19	13	69	142	48
	CTHN-80	5	30	61	20	13	76	155	51
	CTHN-100	5	32	63	20	13	81	160	51
	CTHN-125	5	35	66	20	13	89	168	51
	CTHN-150	5	39	73	21	13	99	185	53
	CTHN-175	8	44	75	26	20	112	191	66
	CTHN-200	8	47	76	30	20	119	193	76

FIGURE 8: U-TUBE, 45°

	Model	(inches)				(centimeters)			
		A	B	C	D	A	B	C	D
	CTHN-40	- UNAPPROVED -				- UNAPPROVED -			
	CTHN-60	8	4	47	40	20	10	119	102
	CTHN-80	8	4	54	46	20	10	137	117
	CTHN-100	8	4	57	48	20	10	145	122
	CTHN-125	8	4	63	53	20	10	160	135
	CTHN-150	8	4	66	56	20	10	168	142
	CTHN-175	8	4	69	59	20	10	175	150
	CTHN-200	8	4	73	63	20	10	185	160

FIGURE 9: U-TUBE, OPPOSITE 45° REFLECTOR

	Model	(inches)				(centimeters)			
		A	B	C	D	A	B	C	D
	CTHN-40	- UNAPPROVED -				- UNAPPROVED -			
	CTHN-60	8	45	45	10	20	114	114	25
	CTHN-80	9	55	54	10	23	140	137	25
	CTHN-100	10	56	57	10	25	142	145	25
	CTHN-125	10	58	63	10	25	147	160	25
	CTHN-150	10	61	66	20	25	155	168	51
	CTHN-175	10	68	69	20	25	173	175	51
	CTHN-200	10	71	73	20	25	180	185	51

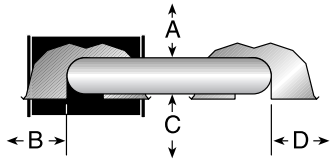
NOTE: 1. All dimensions are from the surfaces of all tubes, couplings and elbows.
 2. Clearances B, C and D can be reduced by 50% after 25' (7.5 m) of tubing downstream from where the burner and burner tube connect.

FIGURE 10: 2-FOOT DECO GRILLE AND PROTECTIVE GRILLE

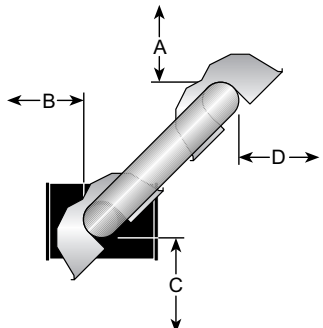
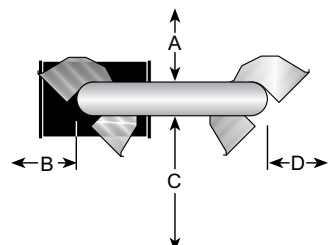
	Model	(inches)				(centimeters)			
		A	B	C	D	A	B	C	D
	CTHN-40	5	20	41	20	13	51	104	51
	CTHN-60	5	27	51	27	13	69	130	69
	CTHN-80	5	30	58	30	13	76	147	76
	CTHN-100	5	32	60	32	13	81	152	81
	CTHN-125	5	35	65	35	13	89	165	89
	CTHN-150	5	39	71	39	13	99	180	99
	CTHN-175	8	44	74	44	20	112	188	112
	CTHN-200	8	47	76	47	20	119	193	119

FIGURE 11: LOWER CLEARANCE SHIELD*

	Model	(inches)				(centimeters)			
		A	B	C	D	A	B	C	D
	CTHN-40	5	25	22	25	13	64	56	64
	CTHN-60	5	30	27	30	13	76	69	76
	CTHN-80	5	37	37	37	13	94	94	94
	CTHN-100	5	39	39	39	13	99	99	99
	CTHN-125	5	41	41	41	13	104	104	104
	CTHN-150	5	43	50	43	13	109	127	109
	CTHN-175	- UNAPPROVED -				- UNAPPROVED -			
	CTHN-200	- UNAPPROVED -				- UNAPPROVED -			

*When installed in the first 10' (3 m).

FIGURE 12: VENTING

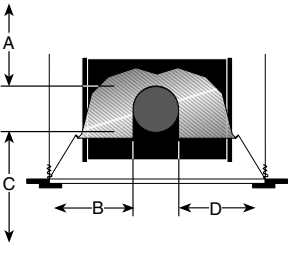
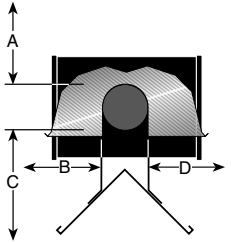
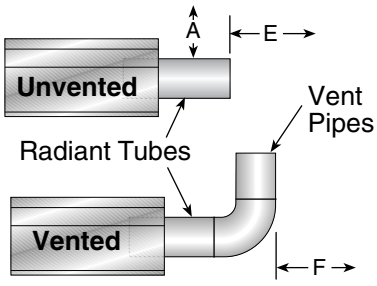
	Model	(inches)			(centimeters)		
		A	E	F	A	E	F
	CTHN-40	14	18	18	36	46	46
	CTHN-60	14	18	18	36	46	46
	CTHN-80	20	24	18	51	61	46
	CTHN-100	20	24	18	51	61	46
	CTHN-125	20	24	18	51	61	46
	CTHN-150	20	30	18	51	76	46
	CTHN-175	20	30	18	51	76	46
	CTHN-200	20	30	18	51	76	46

SECTION 4: NATIONAL STANDARDS AND APPLICABLE CODES

4.1 Gas Codes

The type of gas appearing on the nameplate must be the type of gas used. Installation must comply with national and local codes and requirements of the local gas company.

United States: Refer to National Fuel Gas Code NFPA 54/ANSI Z223.1 - latest revision.

Canada: Refer to Natural Gas and Propane Installation Code CSA B149.1 - latest revision.

4.2 Aircraft Hangars

Installation in aircraft hangars must be in accordance with the following codes:

United States: Refer to Standard for Aircraft Hangars, NFPA 409 - latest revision.

Canada: Refer to Natural Gas and Propane Installation Code CSA B149.1 - latest revision.

In aircraft storage and servicing areas, heaters shall be installed at least 10' (3 m) above the upper surface of wings or of engine enclosures of the highest aircraft which may be housed in the hangar. The measurement shall be made from the wing or engine enclosure (whichever is higher from the floor) to the bottom of the heater.

- In shops, offices and other sections of aircraft hangars communicating with aircraft storage or servicing areas, heaters shall be installed not less than 8' (2.4 m) above the floor.
- Suspended or elevated heaters shall be so located in all spaces of aircraft hangars that they shall not be subject to injury by aircraft, cranes, movable scaffolding or other objects. Provisions shall be made to assure accessibility to suspended heaters for recurrent maintenance purposes.

4.3 Public Garages

Installation in garages must be in accordance with the following codes:

United States: Refer to Standard for Parking Structures NFPA 88A - latest revision or the Code for Motor Fuel Dispensing Facilities and Repair Garages, NFPA 30A - latest revision.
Canada: Refer to Natural Gas and Propane Installation Code CSA B149.1 - latest revision.

- Heaters must not be installed less than 8' (2.4 m) above the floor. Minimum clearances to combustibles must be maintained from vehicles parked below the heater.
- When installed over hoists, minimum clearances to combustibles must be maintained from the upper most point of objects on the hoist.

4.4 Electrical

The heater must be electrically grounded in accordance with the following codes:

United States: Refer to National Electrical Code®, NFPA 70 - latest revision. Wiring must conform to the most current National Electrical Code®, local ordinances and any special diagrams furnished.

Canada: Refer to Canadian Electrical Code, CSA C22.1 Part 1 - latest revision.

4.5 Venting

The venting must be installed in accordance with the requirements within this manual and the following codes:

United States: Refer to National Fuel Gas Code NFPA 54/ANSI Z223.1 - latest revision.

Canada: Refer to Natural Gas and Propane Installation Code CSA B149.1 - latest revision.

4.6 High Altitude

These heaters are approved for installations up to 2000' (610 m)(US), 4500' (1370 m)(Canada) without modification. Consult factory if US installation is above 2000' (610 m) or Canadian installation is above 4500' (1370 m).

SECTION 5: HEATER DESCRIPTIONS

5.1 Unitary vs. Multiburner

CTHN-Series burners may be used for unitary heaters or for multiburner systems.

Unitary heaters consist of a single burner, a single run of radiant tubing and a single fan assembly. See *Page 18, Figure 15* or *See Page 21, Figure 18* for details.

Multiburner systems consist of more than one burner and more than one run of radiant tubing. The runs of radiant tubing are connected together by manifold tubing. The manifold tubing connects to a single pump that exhausts the flue gases outdoors. See *Page 36, Figure 21 through Page 39, Figure 25* for common multiburner system layouts.

Since this manual addresses installation of both unitary heaters and multiburner systems, pay close attention to section and figure titles to verify relevance to unitary heaters or multiburner systems.

SECTION 6: MAJOR COMPONENTS

FIGURE 13: Major Component Descriptions

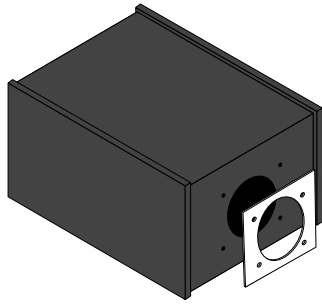
**Burner with Tube Gasket**

Must be installed with the flame observation window facing down.

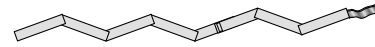
**Turbulator**

Turbulator must be installed in the last standard section of tube. Turbulator is only required on the CTHN-40, 60 and 80. For installation, see *Page 25, Step 8.8.*

**Reflector (Aluminum or Stainless Steel)**

Alternate overlap as shown on *Page 19, Figure 16* or on *Page 22, Figure 19.* Minimum overlap is 6" (16 cm).

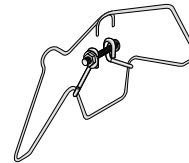
**Flex Gas Line with Shut Off Cock****Tube and Reflector Hanger with Clamp Package**

Position this hanger no more than 4" (10 cm) away from the burner.

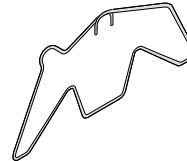
**Tube and Reflector Hanger**

Suspend system from these hangers.

**Burner Tube**

Supplied in 10' (3 m) lengths. Burner tube is always the first tube after the burner.

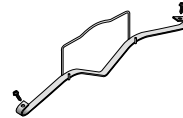
**Reflector Support Strap & Wire Form****Tube**

Hot rolled or heat treated aluminized tube supplied in 10' (3 m) lengths.

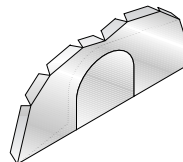
**Reflector End Cap**

Punch out center section to accommodate tube.

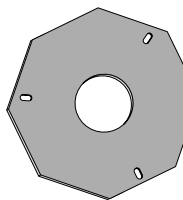
**Coupling Assembly with Lock****Restrictor Plate**

Used at fan assembly inlet for unitary heaters only. See fan assembly below.

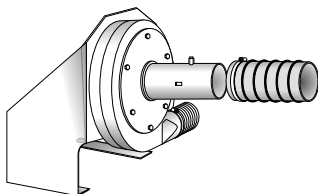
**EP-100 Pump Package -**

For more information, refer to the EP-100 Installation, Operation and Service Manual (P/N 127201NA).

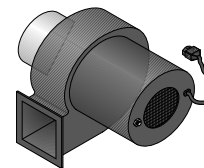
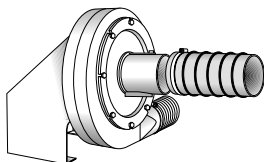
**Fan Assembly****EP-201 Pump Package -**

For more information, refer to the EP-200 Series Installation, Operation and Service Manual (P/N 127200NA).

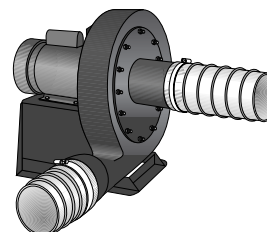
**EP-300 Series**

Pump Package - For more information, refer to the EP-300 Series Installation, Operation and Service Manual (P/N 127202NA).

SECTION 7: GENERAL SUSPENSION DETAILS

⚠ WARNING

Severe Injury Hazard
<p>Secure burner to burner tube with bolts and lockwashers.</p> <p>Hang heater with materials with a minimum working load of 75 lbs (33 kg).</p> <p>Failure to follow these instructions can result in death, injury or property damage.</p>

⚠ WARNING

Cut/Pinch Hazard
<p>Wear protective gear during installation, operation and service.</p> <p>Edges are sharp.</p> <p>Failure to follow these instructions can result in injury.</p>

To ensure your safety and comply with the terms of the warranty, all units must be installed in accordance with these instructions. The gas or the electrical supply lines must not be used to support the heater. Do not locate the gas or electric supply lines directly over the path of the flue products from the heater. The heater must be installed in a location that is readily accessible for servicing. The heaters must be installed in accordance with clearances to combustibles as indicated on the rating plate and in this instruction manual. The minimum and maximum gas inlet pressures must be maintained as indicated on the rating plate. Typical installation configurations are shown on Page 13, Figure 14.

Expansion and contraction of the tube dictates that the minimum suspension lengths must be maintained. See table on Page 13, Figure 14.

FIGURE 14: Critical Hanger Placement

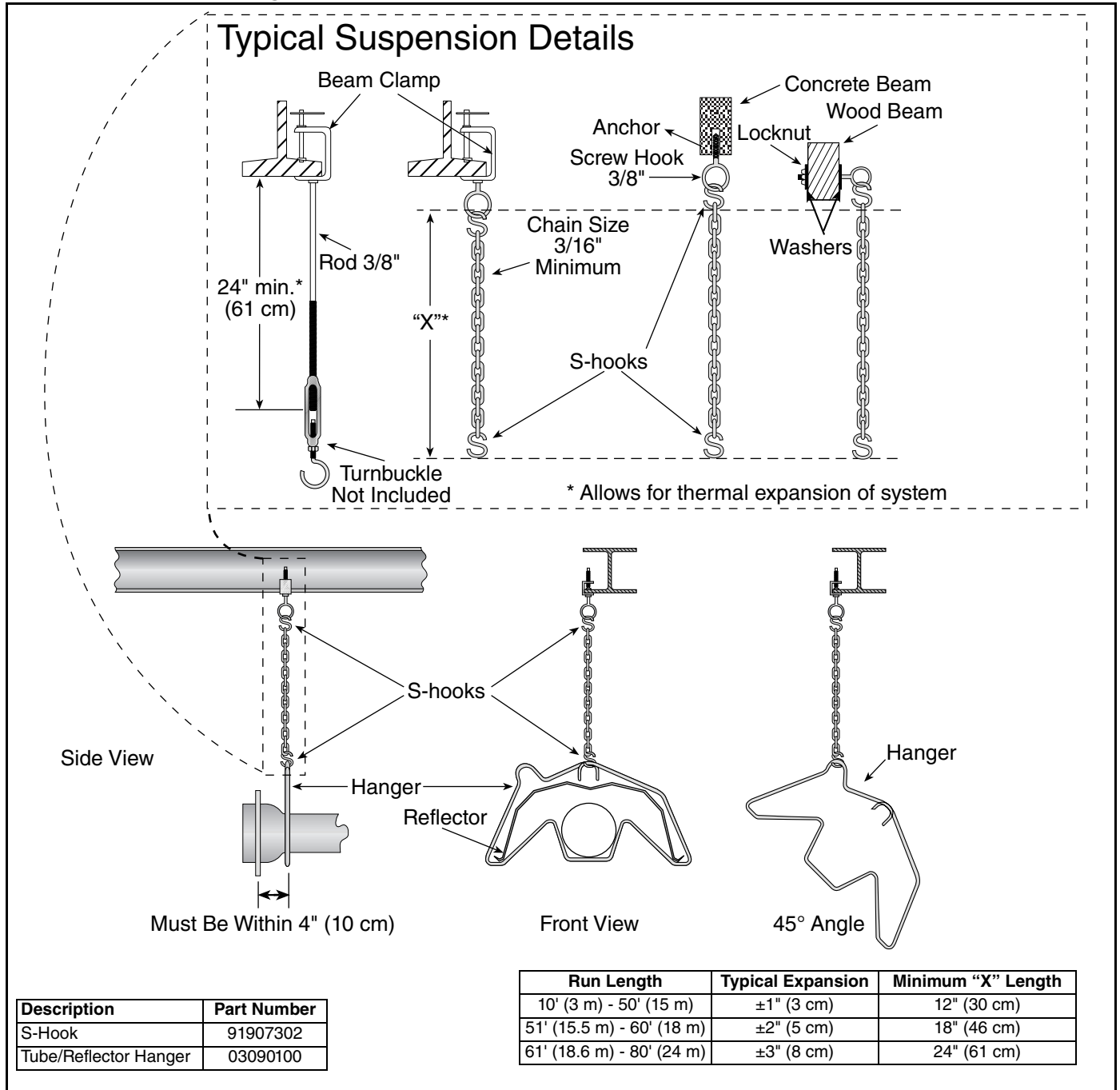

SECTION 8: UNITARY LINEAR & U-TUBE HEATER INSTALLATION

⚠ WARNING



Severe Injury Hazard

Secure burner to burner tube with bolts and lockwashers.

Hang heater with materials with a minimum working load of 75 lbs (33 kg).

Failure to follow these instructions can result in death, injury or property damage.

⚠ WARNING



Cut/Pinch Hazard

Wear protective gear during installation, operation and service.

Edges are sharp.

Failure to follow these instructions can result in injury.

8.1 Standard Parts

Table 1: Contents of CTHN Burner Carton

Part No.	Description	CTHN-40	CTHN-60	CTHN-80	CTHN-100	CTHN-125	CTHN-150	CTHN-175	CTHN-200
BH52XXXXX	Burner (Rate and Fuel Varies)	1	1	1	1	1	1	1	1
07730400	Restrictor Plate 1.25" (3.2 cm) dia.	1	-	-	-	-	-	-	-
07730100	Restrictor Plate 1.50" (3.8 cm) dia.	-	1	-	-	-	-	-	-
07730500	Restrictor Plate 2.25" (5.7 cm) dia.	-	-	-	1	1	-	-	-
07730600	Restrictor Plate 2.50" (6.4 cm) dia.	-	-	-	-	-	-	1	-
07730700	Restrictor Plate 2.75" (7 cm) dia.	-	-	-	-	-	1	-	-
03051503	Turbulator Adapter	1	1	1	-	-	-	-	-
03051504	Turbulator Section	2	4	4	-	-	-	-	-
03051505	Turbulator Section, Stainless Steel	1	-	-	-	-	-	-	-
*91412200	Flexible Stainless Steel Gas Hose , 1/2" NPT (US Models Only)	1	1	1	1	1	-	-	-
*91412204	Flexible Stainless Steel Gas Hose , 3/4" NPT (US Models Only)	-	-	-	-	-	1	1	1
02568200	Gasket (Burner to Burner Tube)	1	1	1	1	1	1	1	1
94273914	Hex Head Cap Screw 5/16" -18 x 7/8"	4	4	4	4	4	4	4	4
96411600	Split Lock Washer	4	4	4	4	4	4	4	4
91201708	Pipe Nipple 1/2" NPT x 4"	1	1	1	1	1	1	1	1
152102NA	Installation, Operation and Service Manual	1	1	1	1	1	1	1	1

*Canadian Models: Rubber (Type 1) Gas Hoses available as an accessory. See Page 70, Section 16.

Table 2: Contents of Core and Extension Packages

Part No.	Description	Core Packages								Extension Packages							
		Hot Rolled				Aluminized				Hot Rolled				Aluminized			
		20' (6 m)	30' (9 m)	40' (12 m)		10' (3 m)	20' (6 m)	30' (9 m)	40' (12 m)	10' (3 m)	20' (6 m)	30' (9 m)	40' (12 m)	10' (3 m)	20' (6 m)	30' (9 m)	40' (12 m)
91409300	Tube, Hot Rolled Steel, 10' (3 m)	1	2	3		-	-	-	-	1	2	3	4	-	-	-	-
91409408	Tube, HT Aluminized, 10' (3 m)	-	-	-		-	1	2	3	-	-	-	-	1	2	3	4
03051101	Burner Tube, ALUMI-THERM® Steel, 10' (3 m)	-	1	1		-	-	1	1	-	-	-	-	-	-	-	-
03051601	Burner Tube, HT ALUMI-THERM® Steel, 10' (3 m)	1	-	-		1	1	-	-	-	-	-	-	-	-	-	-
01312700	Coupling Assembly	1	2	3		-	1	2	3	1	2	3	4	1	2	3	4
02750303	Standard Reflector, 8' (2.4 m)	3	4	6		2	3	4	6	2	3	4	6	2	3	4	6
02750800	End Cap	2	2	2		2	2	2	2	-	-	-	-	-	-	-	-
03090100	Tube and Reflector Hanger	3	4	5		2	3	4	5	1	2	3	4	1	2	3	4
91907302	S-hook	3	4	5		2	3	4	5	1	2	3	4	1	2	3	4
03050010	Reflector Support Package (Strap, Wire Form, Screws)	2	3	5		1	2	3	5	2	3	4	6	2	3	4	6
91107720	U-clip Package	1	1	1		1	1	1	1	1	1	1	1	1	1	1	1
90502700	Vent Adapter (Not used on CTHN)	1	1	1		1	1	1	1	-	-	-	-	-	-	-	-
01318901	Tube Clamp Package	1	1	1		1	1	1	1	-	-	-	-	-	-	-	-

Table 3: Component Package Guide

Model	Tubing Length	Core Packages	
	Minimum	Standard	Aluminized
CTHN-40	10' (3 m)	CP10ALUM	CP10ALUM
CTHN-60	20' (6 m)	CP20HRS	CP20ALUM
CTHN-80	20' (6 m)	CP20HRS	CP20ALUM
CTHN-100	30' (9 m)	CP30HRS	CP30ALUM
CTHN-125	40' (12 m)	CP40HRS	CP40ALUM
CTHN-150	40' (12 m)	CP40HRS	CP40ALUM
CTHN-175	50' (15 m)	CP30HRS + EXP20HRS	CP30ALUM + EXP20ALUM
CTHN-200	50' (15 m)	CP30HRS + EXP20HRS	CP30ALUM + EXP20ALUM

Additional tubing length may be added to heater.

Any additional tubing lengths are considered as vent length for length determination.

Maximum venting length for unitary heater is 45' (13.7 m) total.

For manifold tubing on multiburner systems, heat-treated aluminized or porcelain coated tubing is required.

Table 4: Common CTHN-Series Components

Part No.	Description
Tubing and Related Accessories	
01312700	Coupling, 4" (10 cm) Plain
01312706	Coupling, 6" (15 cm) Plain
01312701	Coupling, 4" (10 cm) Lined
01331900	Coupling, 4" (10 cm) Damper
E0009356	Coupling, 6" (15 cm) Damper
01330203	Tee, 4" (10 cm) Aluminized
01330204	Tee, 6" (15 cm) Aluminized
01335801	Elbow, 4" (10 cm) Aluminized 90°
T0100320	Elbow, 6" (15 cm) Aluminized 90°
01336101	Elbow, 4" (10 cm) Aluminized 45°
91409300	Tube, 4" (10 cm) dia Hot Rolled Steel 10' (3 m)
91409403	Tube, 4" (10 cm) dia Non-Heat Treated Aluminized 10' (3 m)
91409408	Tube, 4" (10 cm) dia Heat Treated Aluminized 10' (3 m)
91409420	Tube, 6" (15 cm) dia Non-Heat Treated Aluminized 10' (3 m)
E0009105	Tube, 6" (15 cm) dia 10' (3 m) Heat Treated Aluminized
91418200	Tube Adapter, 6" (15 cm) dia x 4"(10 cm) dia Aluminized

Part No.	Description
Venting Accessories	
01324401	Air Supply Takeoff, 4" (10 cm) Outside
90707501	Air Supply Blower/Power Venter
91409601	Air Flex Duct, 4" (10 cm) Outside (Box of 8 - 8' (2.4 m) sections)

Part No.	Description
Reflectors and Related Accessories	
01329910	Reflector Side Extension Support
03050010	Reflector Support Package (Tubing)
02712700	Reflector Side Extension, 2 Clips, 2 Screws
02750303	Reflector, Aluminum
027503SS	Reflector, Stainless Steel
02750800	Reflector End Cap, Aluminum
027508SS	Reflector End Cap, Stainless Steel
027508SH	Reflector End Cap, Stainless Steel with Hole
02750900	Reflector Joint
027509SS	Reflector Joint, Stainless Steel
027127SS	Reflector Side Extension, Stainless Steel
03090100	Tube and Reflector Hanger
91907302	S-hook
91903201	Turnbuckle
91903300	Spring Hook
91903202	Turnbuckle with Eyebolt

Part No.	Description
Control Packages and Thermostats	
05023000	Load Relay Package
90417600K	Transformer Relay - SPST (12 A)
90436300	Transformer Relay - DPST (12 A)
90423000	Thermostat, 24 V Low Voltage (Marked 1-5)
90424300	Thermostat Guard

Part No.	Description
Deco Grille (2' x 4' [.6 m x 1.2 m])	
01365900	Shield Frame
01370408	Reflector Side Extension 8" x 48" (20 cm x 122 cm)
01370412	Reflector Side Extension 12" x 48" (30 cm x 122 cm)
01370416	Reflector Side Extension 16" x 48" (40 cm x 122 cm)
91407000	Grille, Aluminum 2' x 4' (.6 m x 1.2 m)

Part No.	Description
Protective Grille	
08050001	Grille, 40" (102 cm) Protective
08050002	Protective Grille End Cap

Part No.	Description
Fan and Pump Packages	
05220000-P	Fan Package 40-150
05221000-P	Fan Package 175-200

8.2 Unitary Heater Requirements

CTHN unitary heaters are typically shipped as a burner package, fan assembly and a tube and accessory package. The tube and accessory packages contain enough tube, reflector and hanging parts for one unitary CTHN heater. Elbows, u-tubes, controls, and any other parts must be purchased separately.

See Page 18, Figure 15 for a general overview of a CTHN unitary heater. CTHN unitary heaters are controlled by thermostat.

Table 5 summarizes the design requirements for a CTHN unitary heater.

Table 5: Unitary Heater Design Requirements

Burner Model:	CTHN-40	CTHN-60	CTHN-80	CTHN-100	CTHN-125	CTHN-150	CTHN-175	CTHN-200
Maximum Number of Burners Allowed per Fan Assembly (P/N 05220000)	1	1	1	1	1	1	-	-
Maximum Number of Burners Allowed per Fan Assembly (P/N 05221000)	-	-	-	-	-	-	1	1
Minimum Radiant Tube Length	10' (3 m)	20' (6 m)	20' (6 m)	30' (9 m)	40' (12 m)	40' (12 m)	50' (15 m)	50' (15 m)
Minimum Distance from Burner to Elbow or U-Tube	10' (3 m)	10' (3 m)	10' (3 m)	15' (4.5 m)	15' (4.5 m)	20' (6 m)	20' (6 m)	20' (6 m)

8.3 Unitary Linear Heater Layouts

FIGURE 15: Linear Heater Assembly Overview

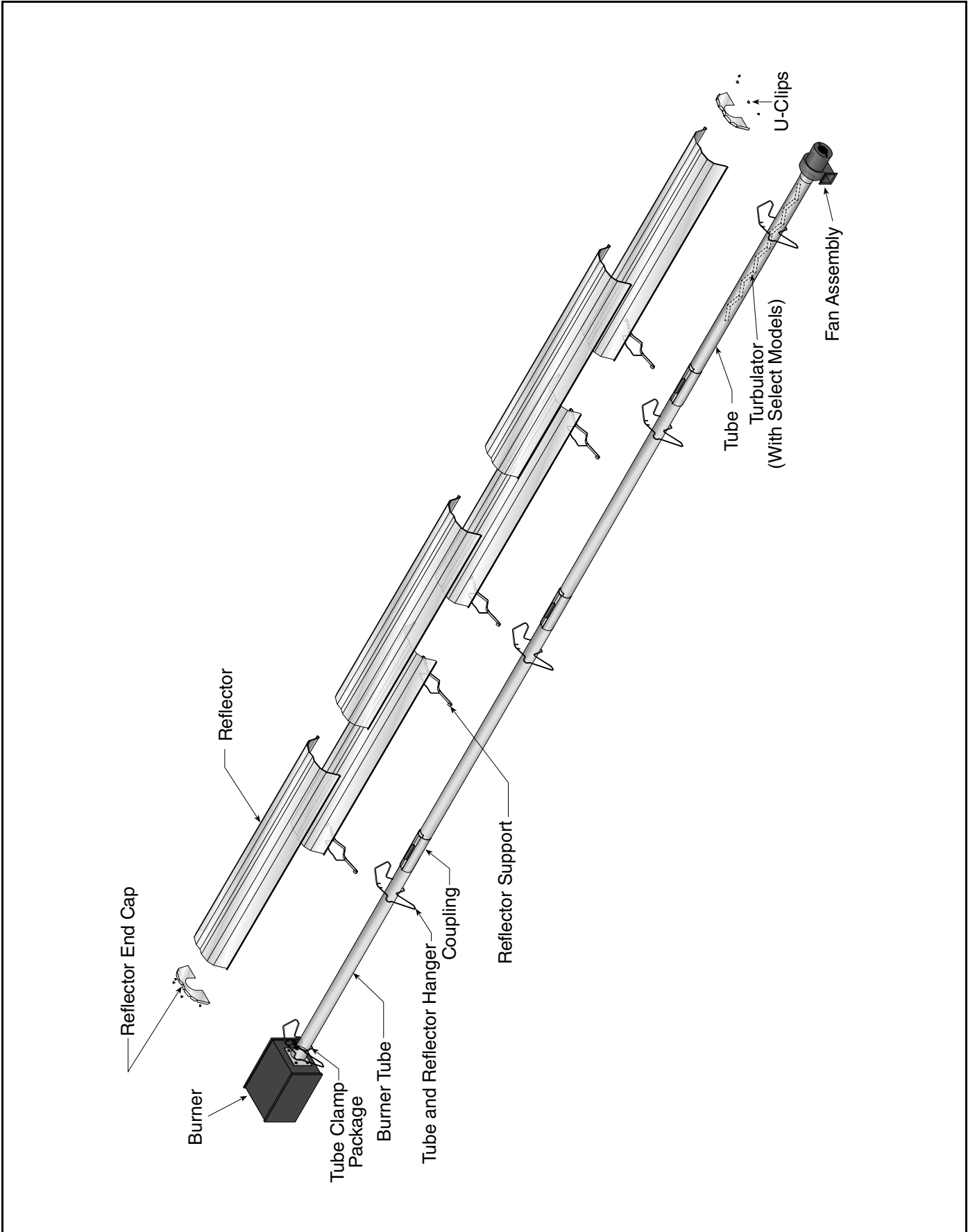







FIGURE 16: Unitary Linear Layout Overview

LEGEND

-  Burner
-  Reflector
-  Tube
-  Tube/Reflector Hanger
-  Coupling Assembly
-  Fan Assembly

a = 14" (36 cm)
reflector width (not shown)

b = 2" (5 cm)
end cap to burner/fan

c = 2" (5 cm)
end cap to hanger

d = 7'6" (229 cm)
distance first hanger

e = 10' (305 cm)
distance between hangers

f = 9.5" (24 cm)
burner height

g = 17.5" (44 cm)
burner length

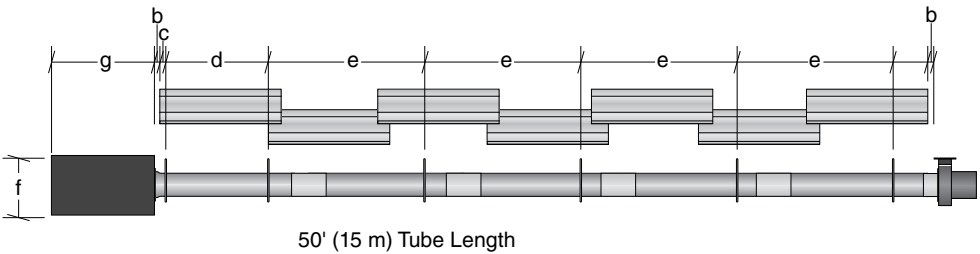
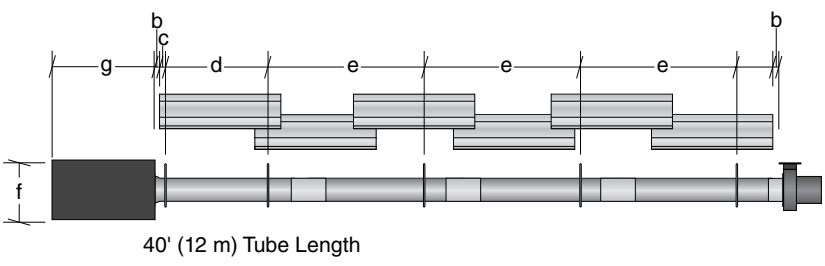
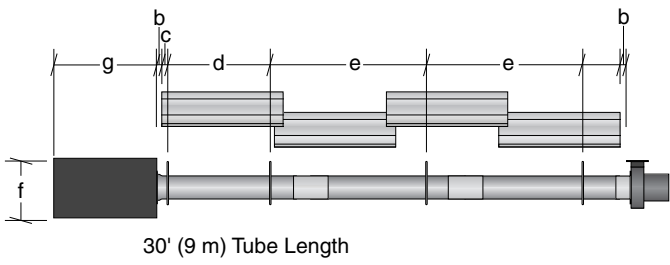
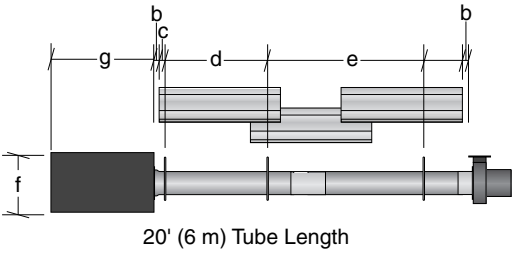
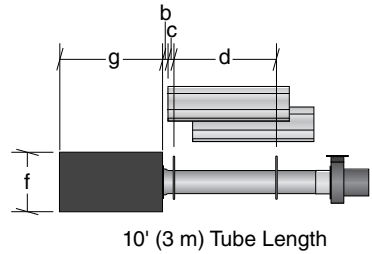

FIGURE 17: Unitary Linear Layout Overview (Continued)



8.4 Unitary U-tube Heater Layouts

CTHN-Series heaters (except CTHN-40) are approved for optional u-tube configurations.

The u-tube may be installed in either a standard horizontal position, 45° position or in an opposite 45° position as shown on Page 7, Figure 7 through Figure 9. When using a u-tube configuration, the following additional rules must be adhered to:

- A minimum of 10' (3 m) on CTHN-60/80, a minimum of 15' (4.5 m) on CTHN-100/125, and a minimum of 20' (6 m) on CTHN-150/175/200 is required between the burner and the u-tube.
- For turbulator installation, See Page 25, Step 8.8.
- The burner must never be operated in a tilted position.

The heater must be properly supported at all locations. See Page 13, Figure 14.

FIGURE 18: U-tube Assembly Overview

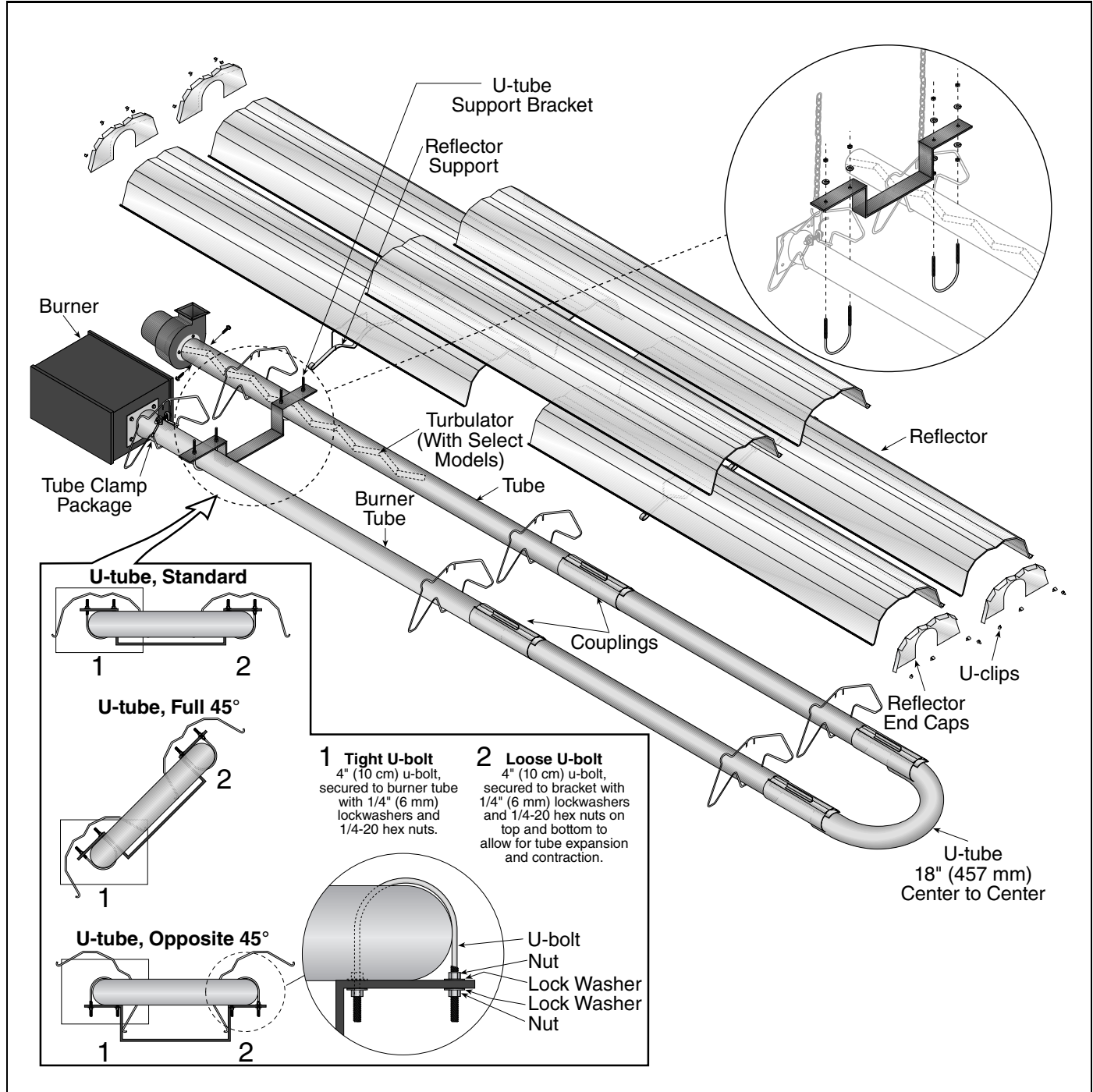
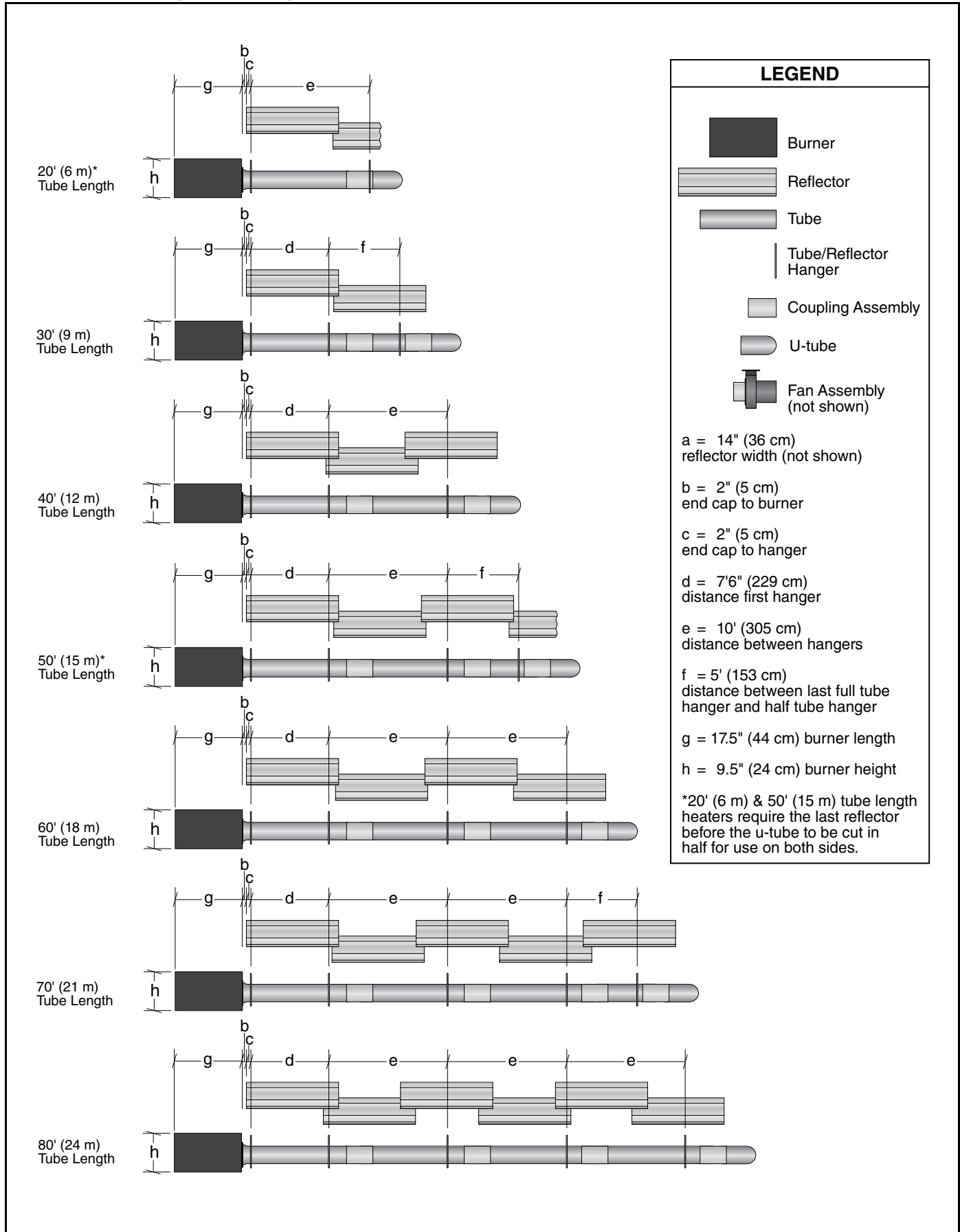
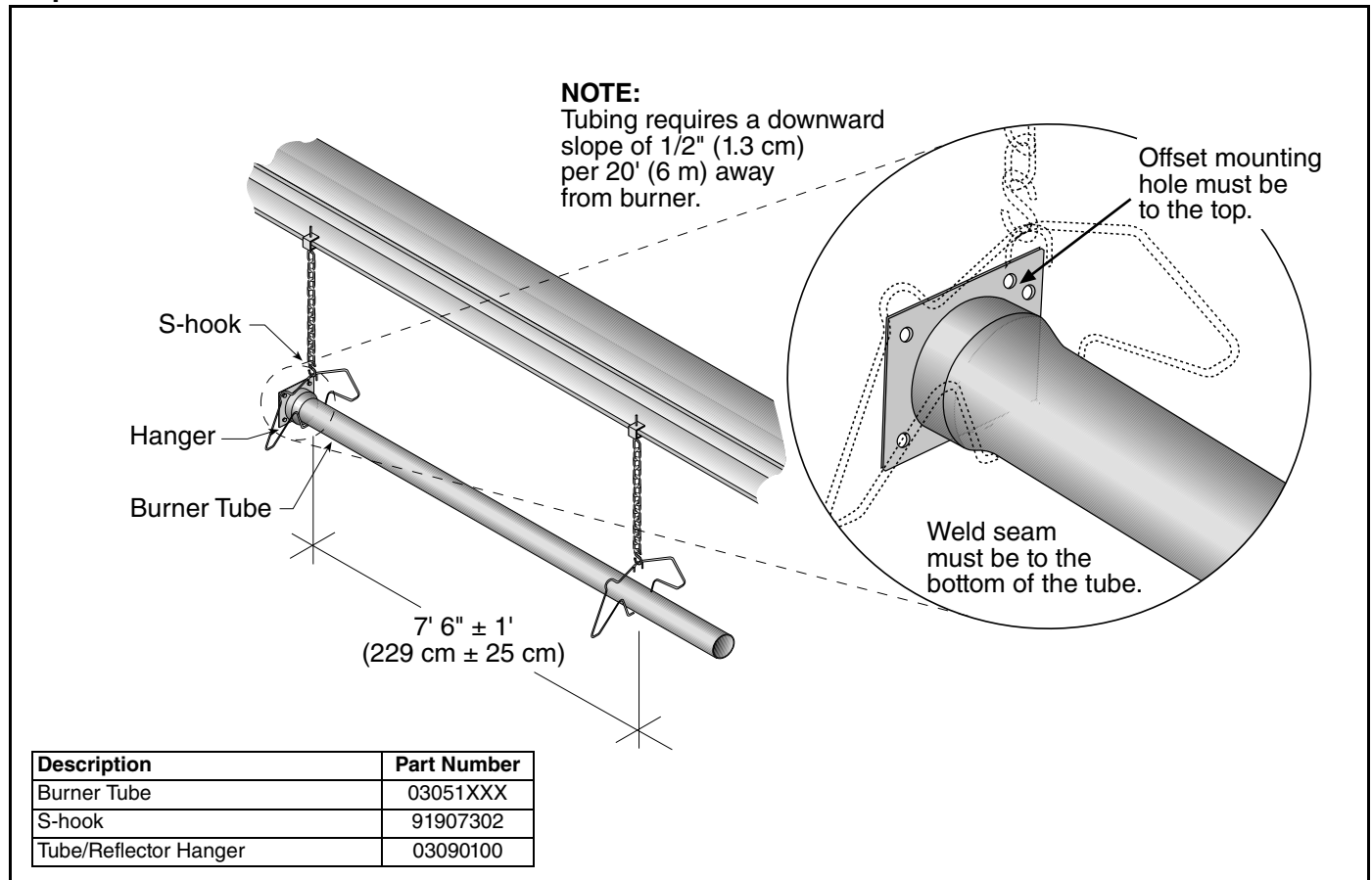

FIGURE 19: Unitary U-tube Layout Overview



Step 8.5 Burner Tube Installation



Step 8.6 Tube Clamp Package Installation

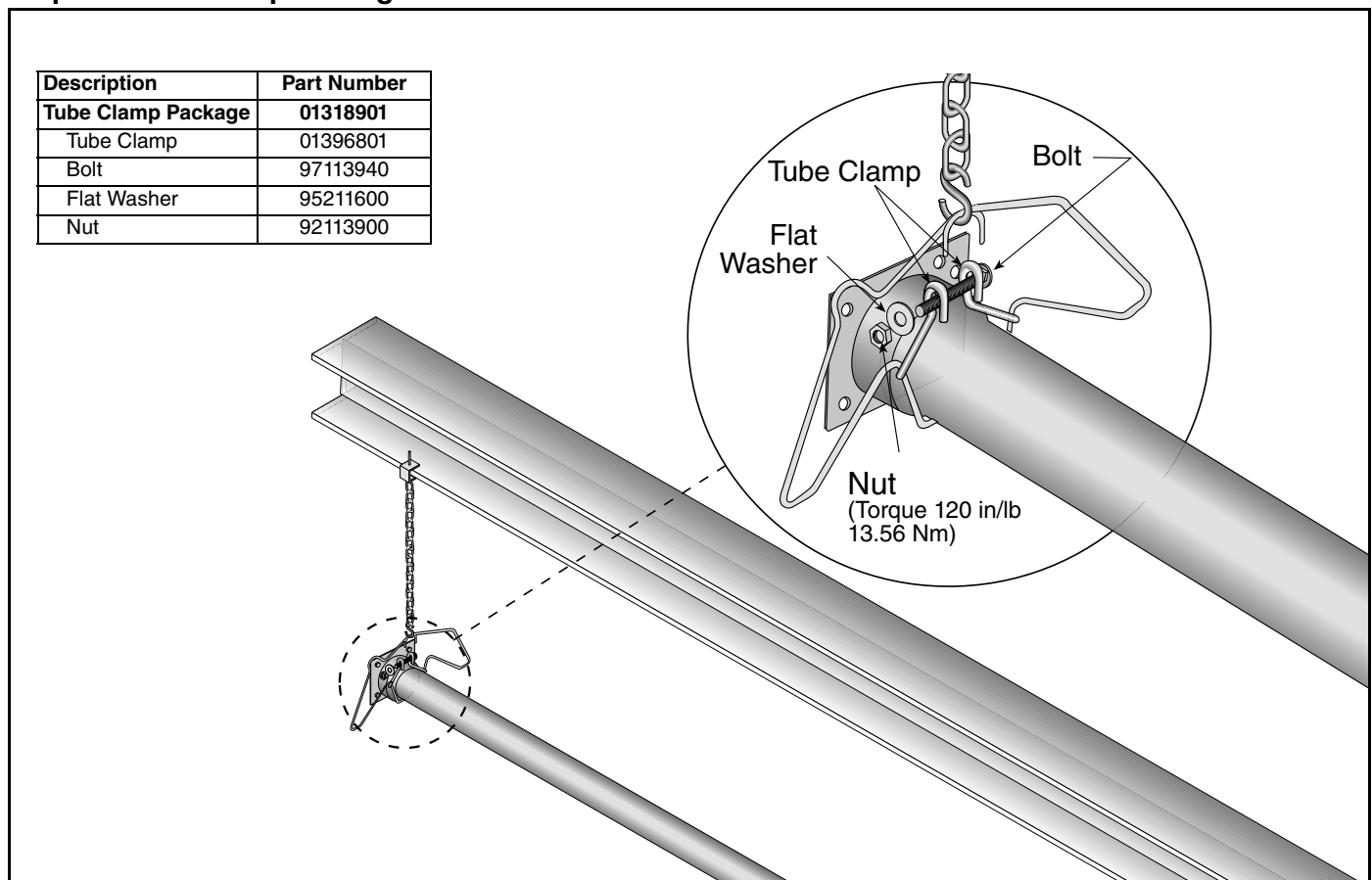

Step 8.7 Coupling and Tube Assembly

A Close coupling with tab.

B Start slide bar/coupling lock onto coupling.

C Insert tubes into coupling.

Orient coupling so that the impact block is in the 2:00 or 10:00 o'clock positions.

D Tighten coupling to join tubes.

Description	Part Number
Coupling	01329600
Slide Bar/Coupling Lock	01329700
Tube	91409XXX

Step 8.7.1 Coupling and Tube Assembly (Continued)

Tighten slide bar as shown below.

Correct slide bar dimensions

Incorrect slide bar position

Drive slide bar until tight. End of slide bar should be within tolerance listed below.

$\pm 2''$ (5 cm)

- Repeat Step 8.7, A - D until all tubes are assembled. See Page 25, Step 8.7.2.

NOTE: If coupling is not tight, loss of vacuum can occur.

Step 8.7.2 Coupling and Tube Assembly (Continued)

The diagram shows a long, cylindrical radiant tube assembly. It is divided into sections. The first section is labeled with dimensions $7' 6'' \pm 1'$ ($2.3 \text{ m} \pm .25 \text{ m}$). The second section is labeled with dimensions $10' \pm 1'$ ($3 \text{ m} \pm .25 \text{ m}$). The entire assembly is labeled as "Total Overall Tube Length".

Model	Radiant Tube Length
CTHN-40	10' (3 m)
CTHN-60	20' (6 m)
CTHN-80	20' (6 m)
CTHN-100	30' (9 m)
CTHN-125	40' (12 m)
CTHN-150	40' (12 m)
CTHN-175	50' (18 m)
CTHN-200	50' (18 m)

Step 8.8 Turbulator Installation

The diagram illustrates the installation of a turbulator section into a radiant tube. A "Turbulator Section" is shown being inserted into the tube. A "Turbulator Adapter" is used to secure the section. A "Tab" is shown being folded around the outside of the tube. A "Pull String" is used to pull the section into the tube. A circular inset shows a close-up of the "Twist" required for the adapter.

Turbulator must be installed in the last standard section of radiant tube. Turbulator is only required on the CTHN-40, CTHN-60 and CTHN-80.

Turbulator Installation	
Model	Tube Section
CTHN-40	1st 10' (3 m) Section
CTHN-60	2nd 10' (3 m) Section
CTHN-80	2nd 10' (3 m) Section
CTHN-100	N/A
CTHN-125	N/A
CTHN-150	N/A
CTHN-175	N/A
CTHN-200	N/A

Turbulator section (stainless) used in CTHN-40 heaters must be in the section of tube nearest to the burner.

Fold tab around outside of tube nearest to the vent to hold turbulator in place.

Description	Part Number
Turbulator Adapter	03051503
Turbulator Section	03051504
Turbulator Section (Stainless)	03051505
Tube	91409XXX

Step 8.9 Reflector Installation

⚠ WARNING



Fire Hazard

Support reflector with reflector hanger and support strap.

Reflector must not touch tube.

Failure to follow these instructions can result in death, injury or property damage.

NOTE: All radiant tube surfaces must be covered by a reflector, except for a u-tube. Manifold tube may or may not be covered.

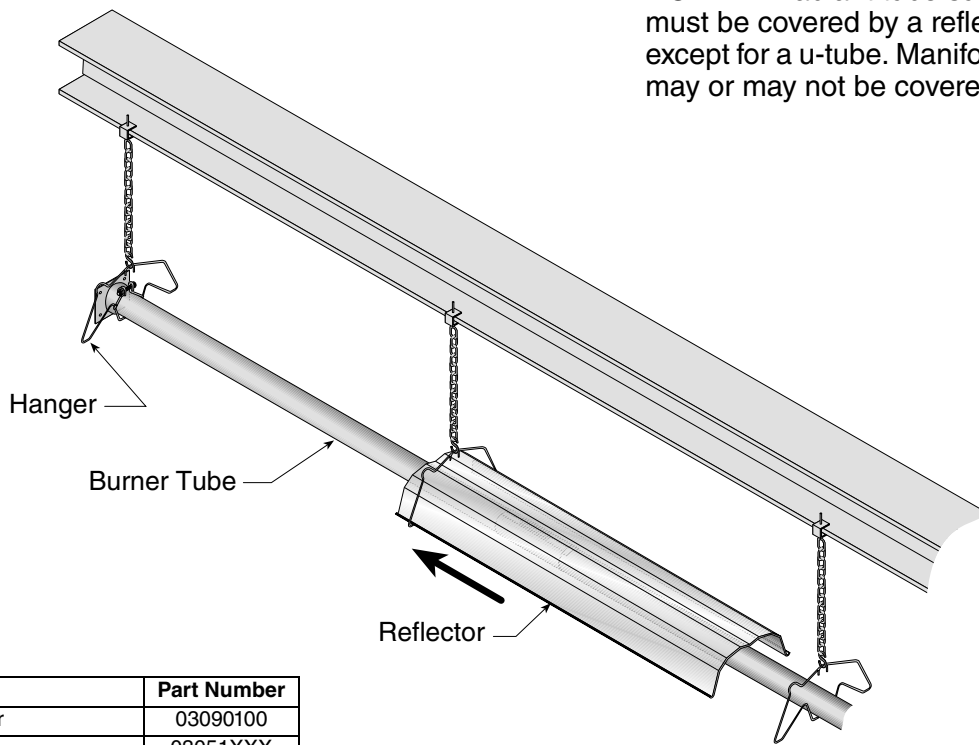

Description	Part Number
Tube/Reflector Hanger	03090100
Burner Tube	03051XXX
Reflector	02750303

Step 8.9.1 Reflector, U-clip and Reflector Support Installation

The pictorial drawings of the heater construction in *Section 8* are schematic only and provide a general guideline of where hangers, reflector supports and u-clips are to be installed.

To ensure proper expansion and contraction movement of the reflectors, a combination of u-clips and reflector supports are used. The positioning of

reflector supports and u-clips depend on the individual installation. Use either pop rivets or sheet metal screws instead of u-clips when installing end caps and joint pieces in areas where impact and high wind may be a factor. The following rules must be observed.

1. The first reflector after the burner must be affixed in the middle of the reflector with a reflector support and tight screws.

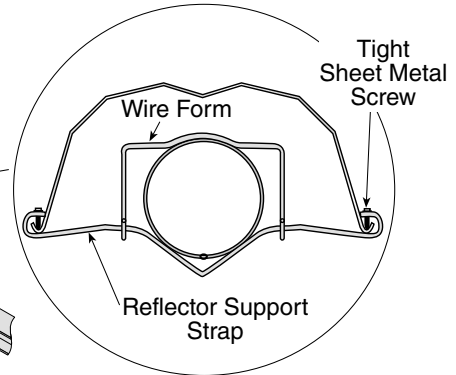
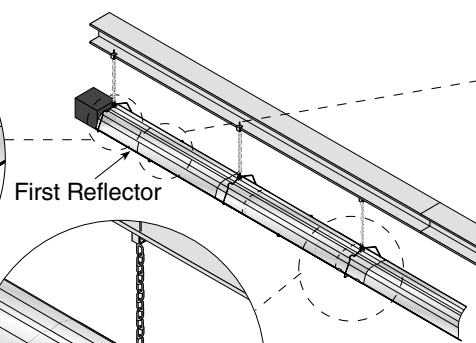
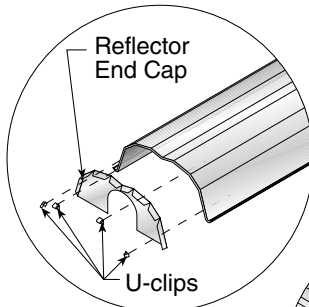

Overlap must be a minimum of 6" (16 cm).

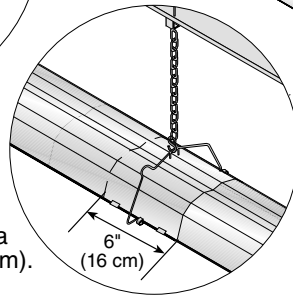

2. The overlap at the first and second reflector is a **slip overlap**. Thereafter, every third reflector joint is a slip overlap. A slip overlap is achieved by either:
- both reflectors lay inside a hanger. (No reflector support needed.)
 - using a reflector support with loose screws at the reflector overlap.

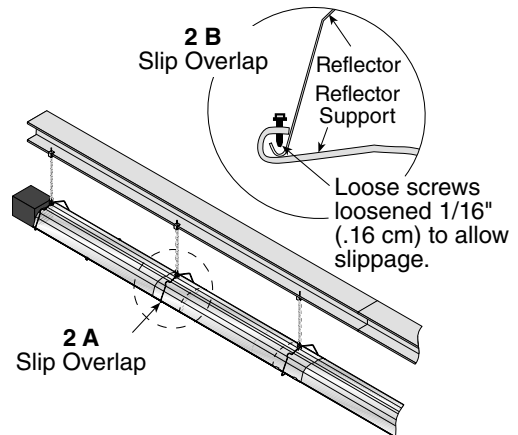

3. The remaining reflector overlaps require a **non-slip overlap** connection. To affix the reflectors together in a non-slip overlap either:
- use reflector support and tight screws.
 - if both reflectors lay inside a hanger, u-clips or sheet metal screws may be used.

This section of three reflectors joined together must be affixed to the tube with at least one reflector support with tight screws.

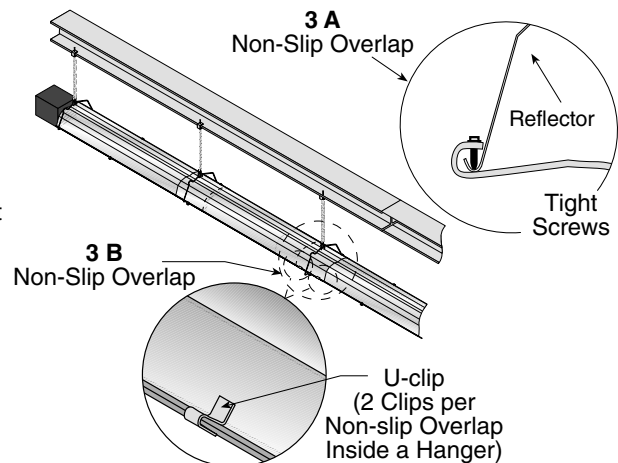

Description	Part Number
Reflector Support Package	03050010
Wire Form	91908004
Reflector Support Strap	03050000
Screw #8 x 3/4	94320812
U-clip Package	91107720
Reflector End Cap	027508XX

Step 8.10 Burner Installation

Diagram illustrating the burner installation. The burner is shown being attached to the burner tube. The burner tube is suspended by a chain and S-hook. The burner is secured to the burner tube with a bolt and lock washer. A gasket is placed between the burner and the burner tube. The burner must be installed with the flame observation window facing down.

Burner must be installed with the flame observation window facing down.

Description	Part Number
Bolt	94273914
Burner	BH52XXXXX
Lock Washer	96411600
Gasket	02568200

Labels in diagram: Burner, Gasket, S-hook, Burner Tube, Lock Washer, Bolt (Torque 120 in/lb 13.56 Nm)

Step 8.11 Fan Inlet Plate and Warning Tag

Diagram illustrating the fan inlet plate and warning tag. The fan inlet plate is shown with a warning tag attached. The warning tag contains the following text:

IMPORTANT!
Remove this tag and install the restrictor plate before assembling fan to the tube.

IMPORTANT!
Enlever l'étiquette et installer la plaque de restriction avant d'assembler le ventilateur au tube.

Remove the warning tag and inlet collar from fan inlet.

Labels in diagram: Remove the warning tag and inlet collar from fan inlet.

Step 8.12 Restrictor Plate Installation

Attach restrictor plate (see chart below right) to fan inlet and replace inlet collar.

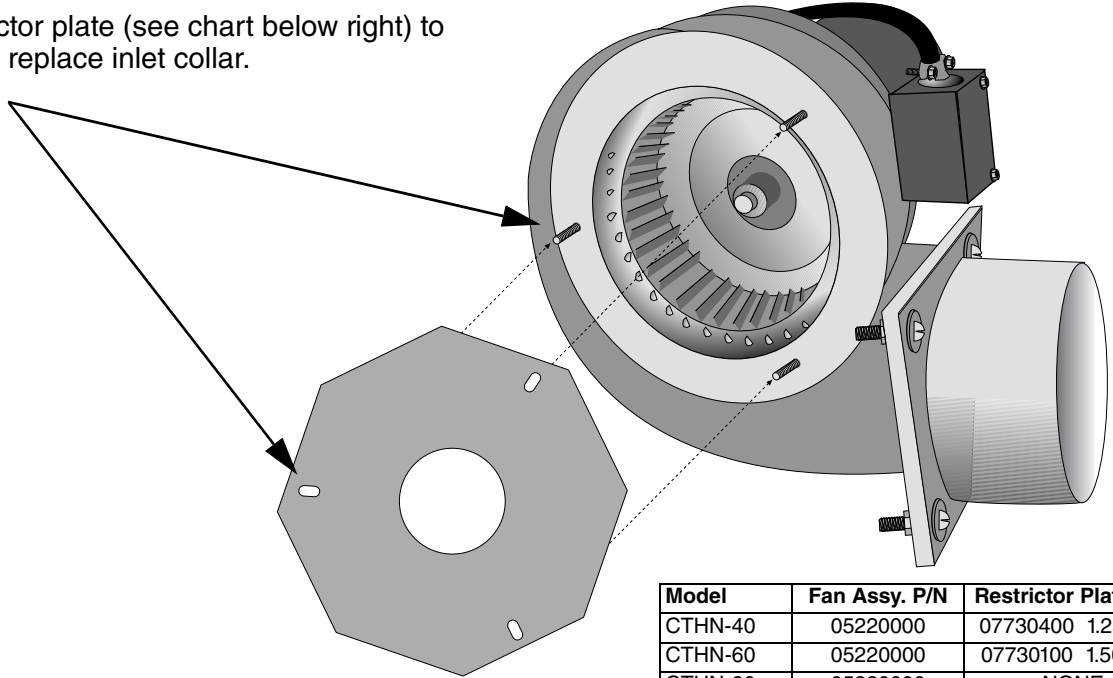

Model	Fan Assy. P/N	Restrictor Plate P/N
CTHN-40	05220000	07730400 1.25" dia
CTHN-60	05220000	07730100 1.50" dia
CTHN-80	05220000	NONE
CTHN-100	05220000	07730500 2.25" dia
CTHN-125	05220000	07730500 2.25" dia
CTHN-150	05220000	07730700 2.75" dia
CTHN-175	05221000	07730600 2.50" dia
CTHN-200	05221000	NONE

Description	Part Number
Restrictor Plate	07730XXX

Step 8.13 Fan Installation

Fold tab around outside of tube nearest to the vent to hold turbulator in place.

Remove warning tag from fan inlet and install restrictor plate if required. See Step 8.12.

Last Tube

Turbulator not required for all models. (See Page 25, Step 8.8 for details.)

Tighten securely until tube cannot be removed.

Vent Adapter

Fan Assembly

Description	Part Number
Fan Assembly 40 - 150	05220000
Fan Assembly 175-200	05221000

SECTION 9: MULTIBURNER HEATER INSTALLATION

⚠ WARNING



Severe Injury Hazard

Secure burner to burner tube with bolts and lockwashers.

Hang heater with materials with a minimum working load of 75 lbs (33 kg).

Failure to follow these instructions can result in death, injury or property damage.

⚠ WARNING



Cut/Pinch Hazard

Wear protective gear during installation, operation and service.

Edges are sharp.

Failure to follow these instructions can result in injury.

9.1 Standard Parts

Table 6: Contents of CTHN Burner Carton

Part No.	Description	CTHN-40	CTHN-60	CTHN-80	CTHN-100	CTHN-125	CTHN-150	CTHN-175	CTHN-200
BH52XXXXX	Burner (Rate and Fuel Varies)	1	1	1	1	1	1	1	1
07730400	Restrictor Plate 1.25" (3.2 cm) dia.	1	-	-	-	-	-	-	-
07730100	Restrictor Plate 1.50" (3.8 cm) dia.	-	1	-	-	-	-	-	-
07730500	Restrictor Plate 2.25" (5.7 cm) dia.	-	-	-	1	1	-	-	-
07730600	Restrictor Plate 2.50" (6.4 cm) dia.	-	-	-	-	-	-	1	-
07730700	Restrictor Plate 2.75" (7 cm) dia.	-	-	-	-	-	1	-	-
03051503	Turbulator Adapter	1	1	1	-	-	-	-	-
03051504	Turbulator Section	2	4	4	-	-	-	-	-
03051505	Turbulator Section, Stainless Steel	1	-	-	-	-	-	-	-
*91412200	Flexible Stainless Steel Gas Hose , 1/2" NPT (US Models Only)	1	1	1	1	1	-	-	-
*91412204	Flexible Stainless Steel Gas Hose , 3/4" NPT (US Models Only)	-	-	-	-	-	1	1	1
02568200	Gasket (Burner to Burner Tube)	1	1	1	1	1	1	1	1
94273914	Hex Head Cap Screw 5/16" -18 x 7/8"	4	4	4	4	4	4	4	4
96411600	Split Lock Washer	4	4	4	4	4	4	4	4
91201708	Pipe Nipple 1/2" NPT x 4"	1	1	1	1	1	1	1	1
152102NA	Installation, Operation and Service Manual	1	1	1	1	1	1	1	1

*Canadian Models: Rubber (Type 1) Gas Hoses available as an accessory. See Page 70, Section 16.

Table 7: Contents of Core and Extension Packages

Part No.	Description	Core Packages								Extension Packages							
		Hot Rolled				Aluminized				Hot Rolled				Aluminized			
		20' (6 m)	30' (9 m)	40' (12 m)		10' (3 m)	20' (6 m)	30' (9 m)	40' (12 m)	10' (3 m)	20' (6 m)	30' (9 m)	40' (12 m)	10' (3 m)	20' (6 m)	30' (9 m)	40' (12 m)
91409300	Tube, Hot Rolled Steel, 10' (3 m)	1	2	3	-	-	-	-	1	2	3	4	-	-	-	-	
91409408	Tube, HT Aluminized, 10' (3 m)	-	-	-	-	1	2	3	-	-	-	-	1	2	3	4	
03051101	Burner Tube, ALUMI-THERM® Steel, 10' (3 m)	-	1	1	-	-	1	1	-	-	-	-	-	-	-	-	
03051601	Burner Tube, HT ALUMI-THERM® Steel, 10' (3 m)	1	-	-	1	1	-	-	-	-	-	-	-	-	-	-	
01312700	Coupling Assembly	1	2	3	-	1	2	3	1	2	3	4	1	2	3	4	
02750303	Standard Reflector, 8' (2.4 m)	3	4	6	2	3	4	6	2	3	4	6	2	3	4	6	
02750800	End Cap	2	2	2	2	2	2	2	-	-	-	-	-	-	-	-	
03090100	Tube and Reflector Hanger	3	4	5	2	3	4	5	1	2	3	4	1	2	3	4	
91907302	S-hook	3	4	5	2	3	4	5	1	2	3	4	1	2	3	4	
03050010	Reflector Support Package (Strap, Wire Form, Screws)	2	3	5	1	2	3	5	2	3	4	6	2	3	4	6	
91107720	U-clip Package	1	1	1	1	1	1	1	1	1	1	1	1	1	1	1	
90502700	Vent Adapter (Not used on CTHN)	1	1	1	1	1	1	1	-	-	-	-	-	-	-	-	
01318901	Tube Clamp Package	1	1	1	1	1	1	1	-	-	-	-	-	-	-	-	

Table 8: Component Package Guide

Model	Tubing Length	Core Packages	
	Minimum	Standard	Aluminized
CTHN-40	20' (6 m)	CP20HRS	CP20ALUM
CTHN-60	30' (9 m)	CP30HRS	CP30ALUM
CTHN-80	30' (9 m)	CP30HRS	CP30ALUM
CTHN-100	40' (12 m)	CP40HRS	CP40ALUM
CTHN-125	50' (15 m)	CP30HRS + EXP20HRS	CP30ALUM + EXP20ALUM
CTHN-150	50' (15 m)	CP30HRS + EXP20HRS	CP30ALUM + EXP20ALUM
CTHN-175	60' (18 m)	CP30HRS + EXP30HRS	CP30ALUM + EXP30ALUM
CTHN-200	60' (18 m)	CP30HRS + EXP30HRS	CP30ALUM + EXP30ALUM

Additional tubing length may be added to heater.

Any additional tubing lengths are considered as manifold tube length for length determination, See Page 33, Section 9.2 through Page 35, Section 9.6, design requirements and allowed manifold tube lengths.

For manifold tubing on multiburner systems, heat-treated aluminized or porcelain coated tubing is required.

Table 9: Common CTHN-Series Components

Part No.	Description
Tubing and Related Accessories	
01312700	Coupling, 4" (10 cm) Plain
01312706	Coupling, 6" (15 cm) Plain
01312701	Coupling, 4" (10 cm) Lined
01331900	Coupling, 4" (10 cm) Damper
E0009356	Coupling, 6" (15 cm) Damper
01330203	Tee, 4" (10 cm) Aluminized
01330204	Tee, 6" (15 cm) Aluminized
01330903	Cross, 4" (10 cm) Aluminized
01330904	Cross, 6" (15 cm) Aluminized
01335801	Elbow, 4" (10 cm) Aluminized 90°
T0100320	Elbow, 6" (15 cm) Aluminized 90°
01336101	Elbow, 4" (10 cm) Aluminized 45°
91409300	Tube, 4" (10 cm) dia Hot Rolled Steel 10' (3 m)
91409403	Tube, 4" (10 cm) dia Non-Heat Treated Aluminized 10' (3 m)
91409408	Tube, 4" (10 cm) dia Heat Treated Aluminized 10' (3 m)
91409420	Tube, 6" (15 cm) dia Non-Heat Treated Aluminized 10' (3 m)
E0009105	Tube, 6" (15 cm) dia 10' (3 m) Heat Treated Aluminized
91418200	Tube Adapter, 6" (15 cm) dia x 4"(10 cm) dia Aluminized
91240010	Tube Hanger, 6" (15 cm)
91308001	Pipe Compound, High Temperature 1lb can

Part No.	Description
Venting Accessories	
01324401	Air Supply Takeoff, 4" (10 cm) Outside
90707501	Air Supply Blower/Power Venter
91409601	Air Flex Duct, 4" (10 cm) Outside (Box of 8 - 8' (2.4 m) sections)

Part No.	Description
Reflectors and Related Accessories	
01329910	Reflector Side Extension Support
03050010	Reflector Support Package (Tubing)
02712700	Reflector Side Extension, 2 Clips, 2 Screws
02750303	Reflector, Aluminum
027503SS	Reflector, Stainless Steel
02750800	Reflector End Cap, Aluminum
027508SS	Reflector End Cap, Stainless Steel
027508SH	Reflector End Cap, Stainless Steel with Hole
02750900	Reflector Joint
027509SS	Reflector Joint, Stainless Steel
027127SS	Reflector Side Extension, Stainless Steel
03090100	Tube and Reflector Hanger
91907302	S-hook
91903201	Turnbuckle
91903300	Spring Hook
91903202	Turnbuckle with Eyebolt

Part No.	Description
Thermostats	
05023000	Load Relay Package
90417600K	Transformer Relay - SPST (12 A)

Part No.	Description
90436300	Transformer Relay - DPST (12 A)
90423000	Thermostat, 24 V Low Voltage (Marked 1-5)
90424300	Thermostat Guard

Part No.	Description
Deco Grille (2' x 4' [.6 m x 1.2 m])	
01365900	Shield Frame
01370408	Reflector Side Extension 8" x 48" (20 cm x 122 cm)
01370412	Reflector Side Extension 12" x 48" (30 cm x 122 cm)
01370416	Reflector Side Extension 16" x 48" (40 cm 122 cm)
91407000	Grille, Aluminum 2' x 4' (.6 m x 1.2 m)

Part No.	Description
Protective Grille	
08050001	Grille, 40" (102 cm) Protective
08050002	Protective Grille End Cap

Part No.	Description
Fan and Pump Packages	
05220000	Fan Package 40-150
05221000	Fan Package 175-200
02719105	EP-100 Pump Package
02719100	EP-100 Pump
02724700	Accessory Package
02716305	EP-201 Pump Package
01312001	EP-201 Pump
01317805	Accessory Package
02712034	EP-203 Pump Package
01312002	EP-203 Pump
01317805	Accessory Package
02723014	EP-301 Pump Package 4" (10 cm)
02730101	EP-301 Pump Assembly
02730104	Accessory Package
02723016	EP-301 Pump Package 6" (15 cm)
02730101	EP-301 Pump Assembly
02730106	Accessory Package
02723034	EP-303 Pump Package 4" (10 cm)
02730103	EP-303 Pump Assembly
02730104	Accessory Package
02723036	EP-303 Pump Package 6" (15 cm)
02730103	EP-303 Pump Assembly
02730106	Accessory Package

Part No.	Description
Pump Accessories	
90430600K	Pressure Switch

Part No.	Description
Contactors Packages	
10050011	Contactors, 120 Vac for EP-203, EP-303, 3 Ø EP-100, EP-201 208/230 V, 1 Ø EP-301 208/230 V, 1 Ø
10050012	Contactors, 120 Vac for EP-301, 120 V, 1 Ø

9.2 Multiburner System Design Requirements

A CTHN multiburner system has a number of radiant tube sections interconnected by manifold tube to a pump to form a complete system. Reflectors can be used over the manifold tube but are not required. The system design parameters are such that the manifold sections are not subjected to condensate when the system is fully heated up. It is required that heat-treated aluminized or coated tubing is used for the manifold to increase system life and to handle initial condensation during start-up. Damper couplings may be necessary to balance system vacuum.

Design requirements for a CTHN multiburner system

are summarized on Page 34, Table 10.

CTHN multiburner heaters are typically shipped as burner packages and tube and accessory packages. The tube and accessory packages contain enough tube, reflector and hanging parts for the radiant section of one CTHN heater. Elbows, tees, manifold tube, pumps, controls, damper couplings and any other parts used beyond the burner, radiant tube and reflector must be purchased separately. See Figure 20 for a general overview of a simple CTHN multiburner system. Depending on system requirements, CTHN multiburner systems may be controlled by a relay system.

FIGURE 20: Typical CTHN Multiburner System Installation

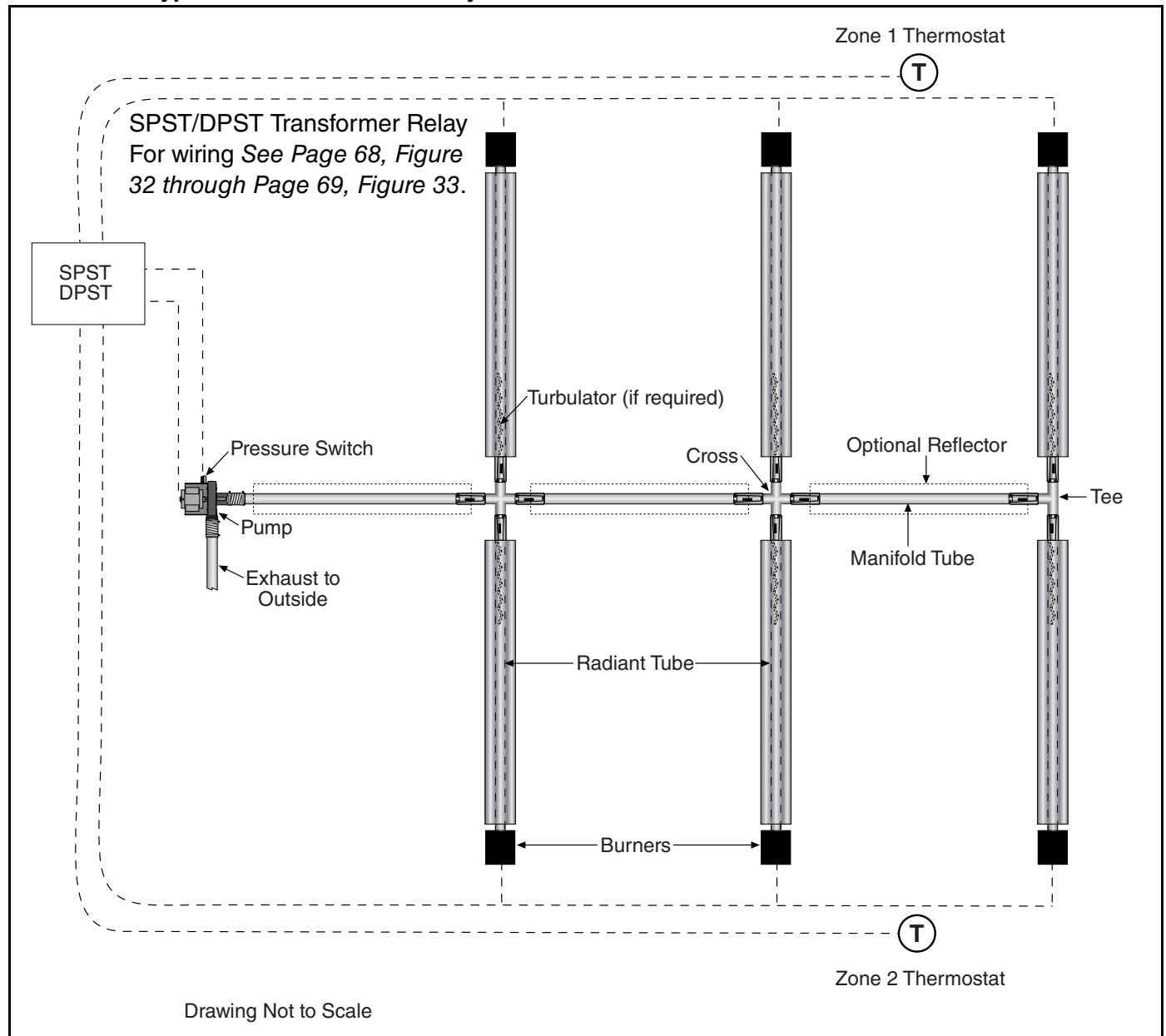

Table 10: Multiburner Design Requirements

Burner Model:	CTHN-40	CTHN-60	CTHN-80	CTHN-100	CTHN-125	CTHN-150	CTHN-175	CTHN-200
Radiant Tube Length	20' (6 m)	30' (9 m)	30' (9 m)	40' (12 m)	50' (15 m)	50' (15 m)	60' (18 m)	60' (18 m)
Minimum Manifold Tube Length per Burner	3' (1 m)	3' (1 m)	3' (1 m)	6' (2 m)	6' (2 m)	10' (3 m)	10' (3 m)	10' (3 m)
Maximum Manifold Tube Length per Burner	30' (9 m)	35' (10.5 m)	40' (12 m)	45' (13.5 m)	50' (15 m)	55' (16.5 m)	60' (18 m)	60' (18 m)
Minimum Distance from Burner to Elbow or U-tube	10' (3 m)	10' (3 m)	10' (3 m)	15' (4.5 m)	15' (4.5 m)	20' (6 m)	20' (6 m)	20' (6 m)
Elbows Allowed per Burner*	2	2	2	2	2	2	2	2

* U-tube = 2 elbows

9.3 Burners Per Pump

1. The maximum number of burners per pump is shown on *Page 34, Table 11*.
2. **When combining different burner inputs** in a system, the number of burners per pump (0' - 2,000' altitude) is given by the sum of their inputs:
 - a. EP-100 up to 500,000 Btu/h max, but not more than 4 burners.
 - b. EP-200 up to 750,000 Btu/h max, but not more than 6 burners.
 - c. EP-300 up to 1,600,000 Btu/h max, number of burners is limited to the maximum number of burners listed on *Page 34, Table 11* for the largest input model used.

Table 11: Number of Burners Allowed Per Pump

Pump Model Altitude CTHN-40 CTHN-60 CTHN-80 CTHN-100 CTHN-125 CTHN-150 CTHN-175 CTHN-200

EP-100	0' - 2,000'	4	4	4	4	4	3	2	2
	2,001' - 3,000'	4	4	4	4	3	3	2	2
	3,001' - 4,000'	4	4	4	4	3	2	2	2
	4,001' - 5,000'	4	4	4	4	3	2	2	2
	5,001' - 6,000'	4	4	4	4	3	2	2	2
	6,001' - 7,000'	4	4	4	3	3	2	2	2
	7,001' - 8,000'	4	4	4	3	3	2	2	1
	8,001' - 9,000'	4	4	4	3	2	2	2	1

EP-200 Series	0' - 2,000'	6	6	6	6	6	5	4	4
	2,001' - 3,000'	6	6	6	6	6	5	4	3
	3,001' - 4,000'	6	6	6	6	5	4	4	3
	4,001' - 5,000'	6	6	6	6	5	4	4	3
	5,001' - 6,000'	6	6	6	6	5	4	3	3
	6,001' - 7,000'	6	6	6	6	5	4	3	3
	7,001' - 8,000'	6	6	6	6	5	4	3	3
	8,001' - 9,000'	6	6	6	6	5	4	3	3

EP-300 Series	0' - 2,000'	16	16	14	12	12	10	8	8
	2,001' - 3,000'	16	16	14	12	12	9	8	7
	3,001' - 4,000'	16	16	14	12	11	9	8	7
	4,001' - 5,000'	16	16	14	12	10	9	7	6
	5,001' - 6,000'	16	16	14	12	10	8	7	6
	6,001' - 7,000'	16	16	14	12	10	8	7	6
	7,001' - 8,000'	16	16	14	12	10	8	6	6
	8,001' - 9,000'	16	16	14	12	10	8	6	6

9.4 Radiant Tube Length

The radiant tube length fixed for each burner is shown on *Page 34, Table 10*.

9.5 Manifold Tube

Any tube beyond the radiant tube length is considered manifold. Manifold tube can be used to lengthen tube runs beyond the radiant tube length; to connect multiple runs of tubing and connect the system to the pump. **Minimum and maximum manifold tube lengths are shown on *Page 34, Table 10*. The table must be used in conjunction with the additional rules for the diameter and length of manifold in a system, as described on *Page 35, Section 9.5.1 through Page 39, Section 9.6.3*.**

9.5.1 Manifold Diameter

1. Manifold diameter for systems containing less than 320,000 Btu/h input can be 4" (10 cm) or 6" (15 cm).
2. Manifold diameter for systems containing 320,000 Btu/h input and greater must be 6" (15 cm).

Exception: If total manifold tube length is 70' (21 m) or less, 4" (10 cm) diameter manifold tube can be used for systems up to 800,000 Btu/h.

9.6 Multiburner System Layouts and Manifold Tube Length Rules

Most CTHN multiburner layouts can be classified as one of the following five layout types:

Flag, Modified In-Series, T, Fork or Herringbone. Please refer to *Page 35, Section 9.6.1 through Page 39, Section 9.6.3* for explanation of manifold rules and basic diagrams of each layout type. The diagrams show very simple examples of each layout type. Actual layouts will vary in total number of burners in the system as well as the overall shape of the system. Additional pieces such as elbows may change the overall layout appearance but are usually considered a variant of one of the five multiburner layout types.

9.6.1 Flag and Modified In-Series Layouts and Manifold Tube Length Rules

See *Page 36, Figure 21 through Page 36, Figure 22* for diagrams of Flag and Modified In-Series layouts. Minimum and maximum manifold tube length applies to all tubing between the end of a radiant tube run and a tee or cross; all tubing between any tees and/or crosses; and all tubing between the last tee or cross and the pump. See *Page 34, Table 10*.

Example: Consider a Flag or Modified In-Series layout with five CTHN-100 burners. *Page 34, Table 10* shows a minimum of 6' (2 m) and a maximum of 45' (13.5 m) of manifold tube required per burner. Therefore the entire five-burner system must have between 30' (10 m) and 225' (69 m) of manifold tubing. The manifold tubing is in addition to the 40' (12 m) of radiant tube per burner. Radiant tube may end at a tee, or runs may be lengthened by adding some manifold tube between the end of the radiant tube and a tee. Each burner in the system (except for the burner furthest from the pump) must use a damper coupling to properly adjust the vacuum at each burner. The damper coupling may be placed anywhere between the end of the radiant pipe and the tee.

FIGURE 21: Flag Layout

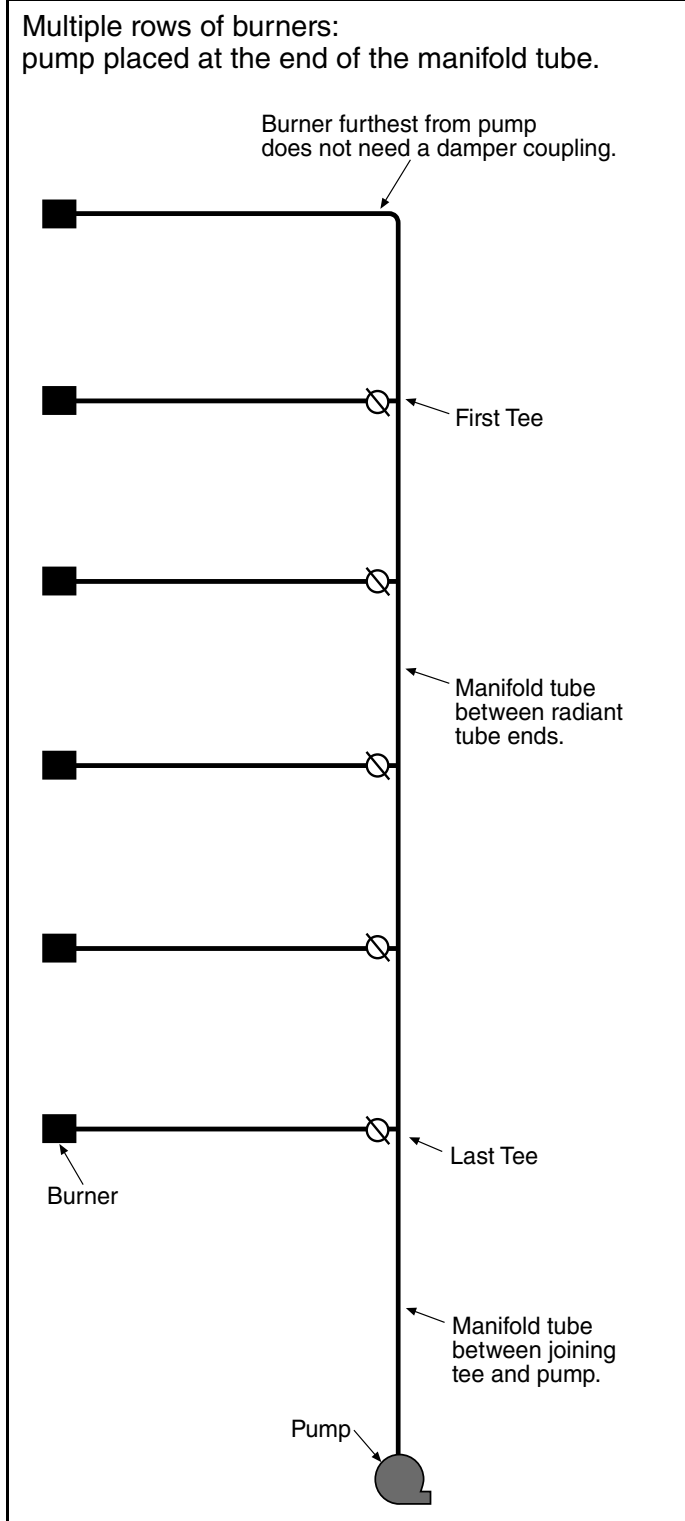
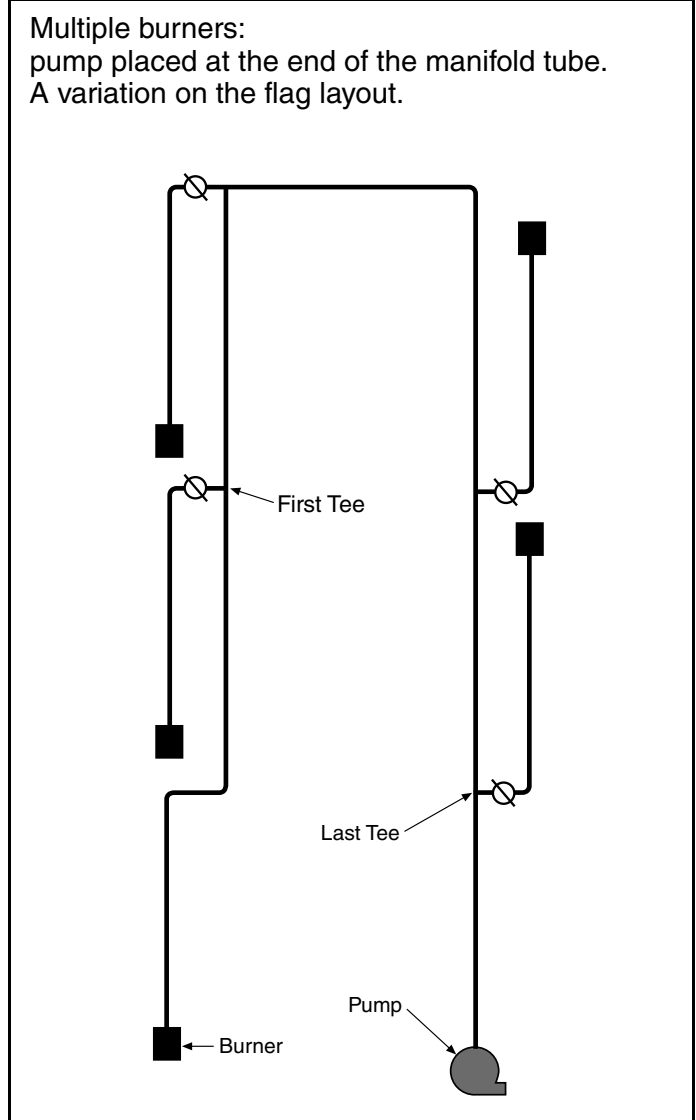

FIGURE 22: Modified In-Series Layout



9.6.2 T and Fork Layouts and Manifold Tube Length Rules

See Page 37, Figure 23 through Page 38, Figure 24 for diagrams of T and Fork layouts. The T and Fork layouts have a tee or cross (called the "last tee" or "last cross") where the combustion gases in the system enter the tee or cross with directly opposing flow directions, which creates an added source of pressure drop in the system. This additional source of pressure drop requires some difference in how the allowed manifold length is calculated. In this case, we have to differentiate manifold tube that is located between the radiant pipe and the last tee (or cross) from manifold tube that is located between the last tee (or cross) and the pump.

First determine the length of manifold tube between the radiant tube end and the last tee (or cross). Do not count any tube length twice. Now refer to Page 34, Table 10 and find the maximum manifold tube length for each burner. Add together the maximum

manifold tube length on the table for each burner in the system, this is the maximum manifold tube length for the entire system.

To determine the maximum manifold tube allowed between the last tee (or cross) and the pump: Subtract the manifold tube length between the radiant tube and the last tee (or cross) from the maximum manifold length for the entire system, then divide that number by 1.5.

Example: Consider a T layout with two CTHN-100 burners. See Page 37, Figure 23. Assume that 15' (4.5 m) of manifold was used from each radiant tube end to the last tee. Page 34, Table 10 indicates that each CTHN-100 burner can have a maximum of 45' (13.5 m) of manifold tube. Therefore the maximum manifold tube length amount allowed between the last tee and the pump in this case is $([45' + 45'] - [15' \times 2]) / 1.5 = 40'$ or in metric, $([13.5 \text{ m} + 13.5 \text{ m}] - [4.5 \text{ m} \times 2]) / 1.5 = 12 \text{ m}$.

FIGURE 23: T Layout

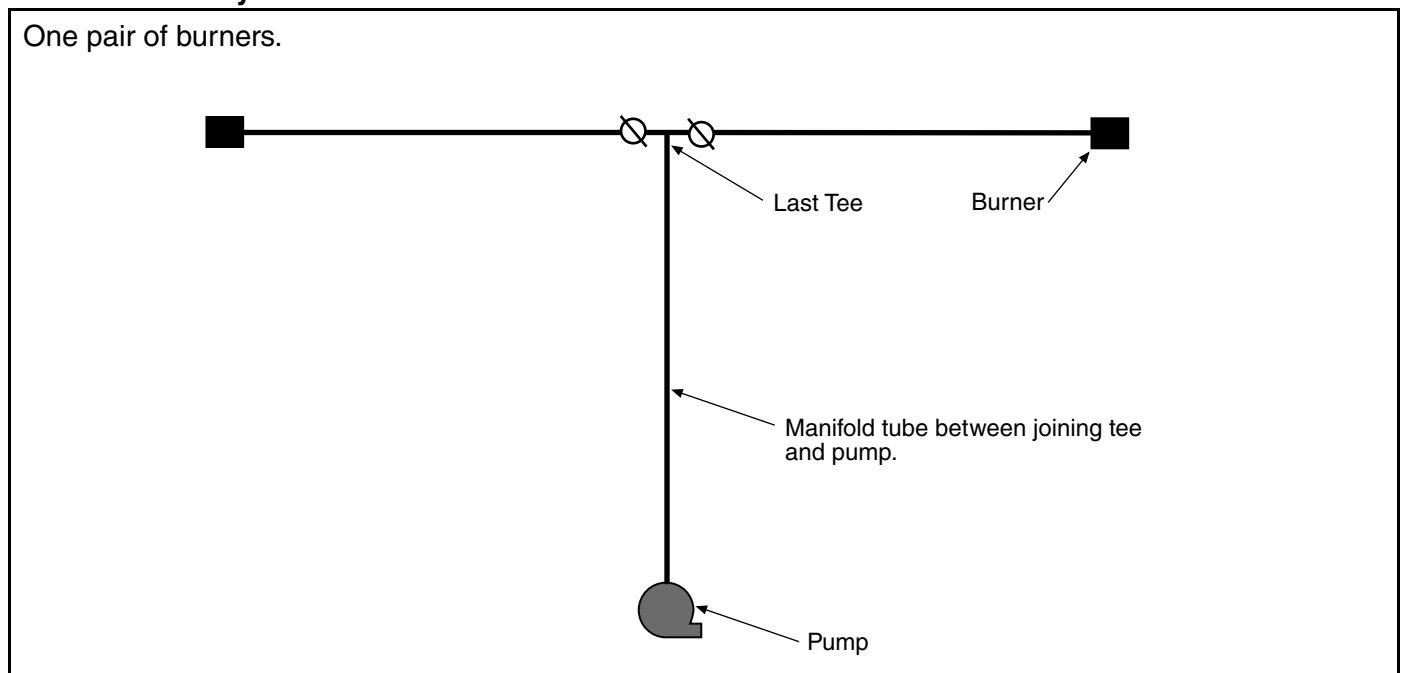
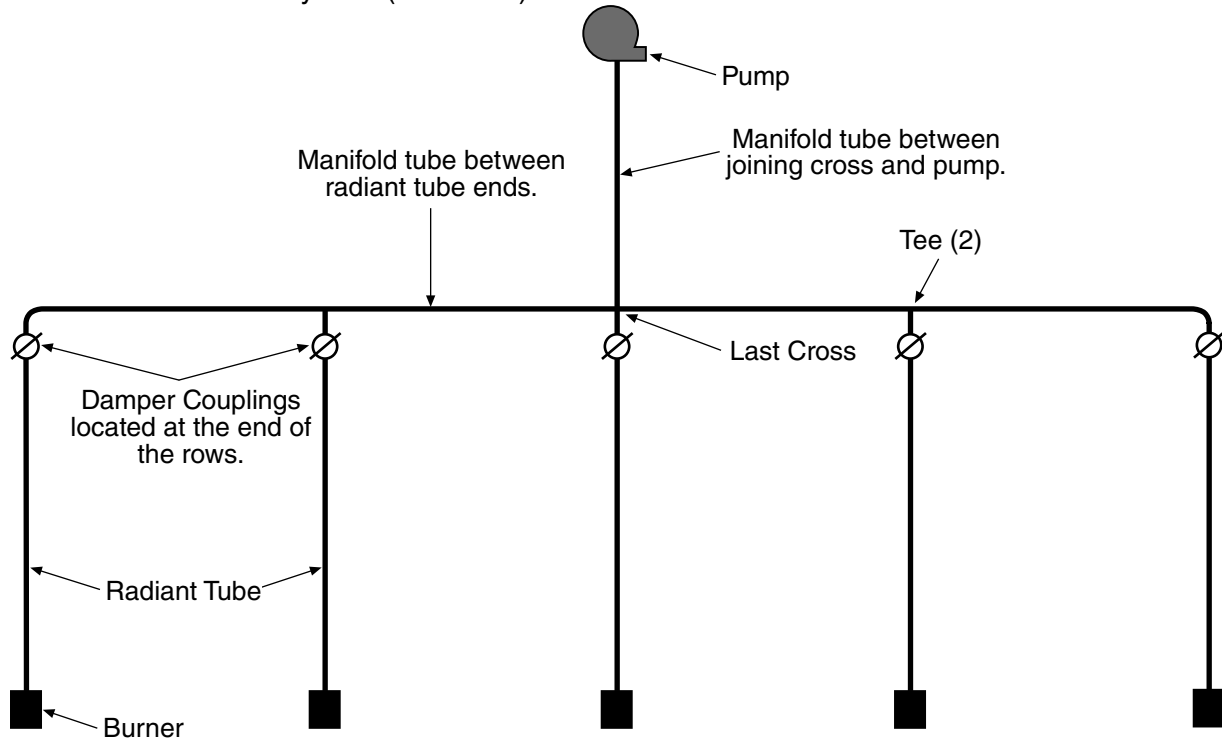

FIGURE 24: Fork Layout

Multiple rows of burners:
 Manifold tube between the last tee or cross and the pump is perpendicular to the manifold tube joining the rows. Pump is not required to be placed in the center of the system (as shown).



9.6.3 Herringbone Layout and Manifold Tube Length Rules

The herringbone layout is essentially several T layouts stacked together. Therefore, the same principle for manifold tube calculation as used for T layouts is used for herringbone layouts, with one exception. In a herringbone layout, the manifold tube length between tees (or crosses) as well as between the last tee (or cross) and the pump is calculated by dividing by 1.5 as shown in the T example on Page 37, Section 9.6.2. The only manifold tube length in a herringbone layout that is not divided by 1.5 is any manifold tube length located between the end of the radiant tube and a tee or cross.

Example: Consider a herringbone layout similar to the layout on the left in Figure 25, having ten CTHN-100 burners. Assume that each heater has 40' (12 m) of radiant tube and 10' (3 m) of manifold tube before the connecting tee or cross.

According to Table 10 each burner must have at least 40' (12 m) of radiant tube, also each burner must have between 6' (2 m) and 45' (13.5 m) of manifold tube. Each burner has already met the minimum manifold pipe requirement due to the 10' (3 m) of manifold tube before the connecting tees and crosses. The maximum manifold tube length for the entire system is 10 burners X 45' (13.5 m) = 450' (135 m). Subtract the 100' (30 m) that has already been used before the connecting tees/crosses and 350' (105 m) remains.

Since the remaining manifold is located either between or after connecting tees or crosses, the manifold length must be divided by 1.5. $350' (105 \text{ m}) / 1.5 = 233' (70 \text{ m})$. Therefore, up to 233' (70 m) can be used between the branches and also between the last cross and the pump.

FIGURE 25: Herringbone Layout

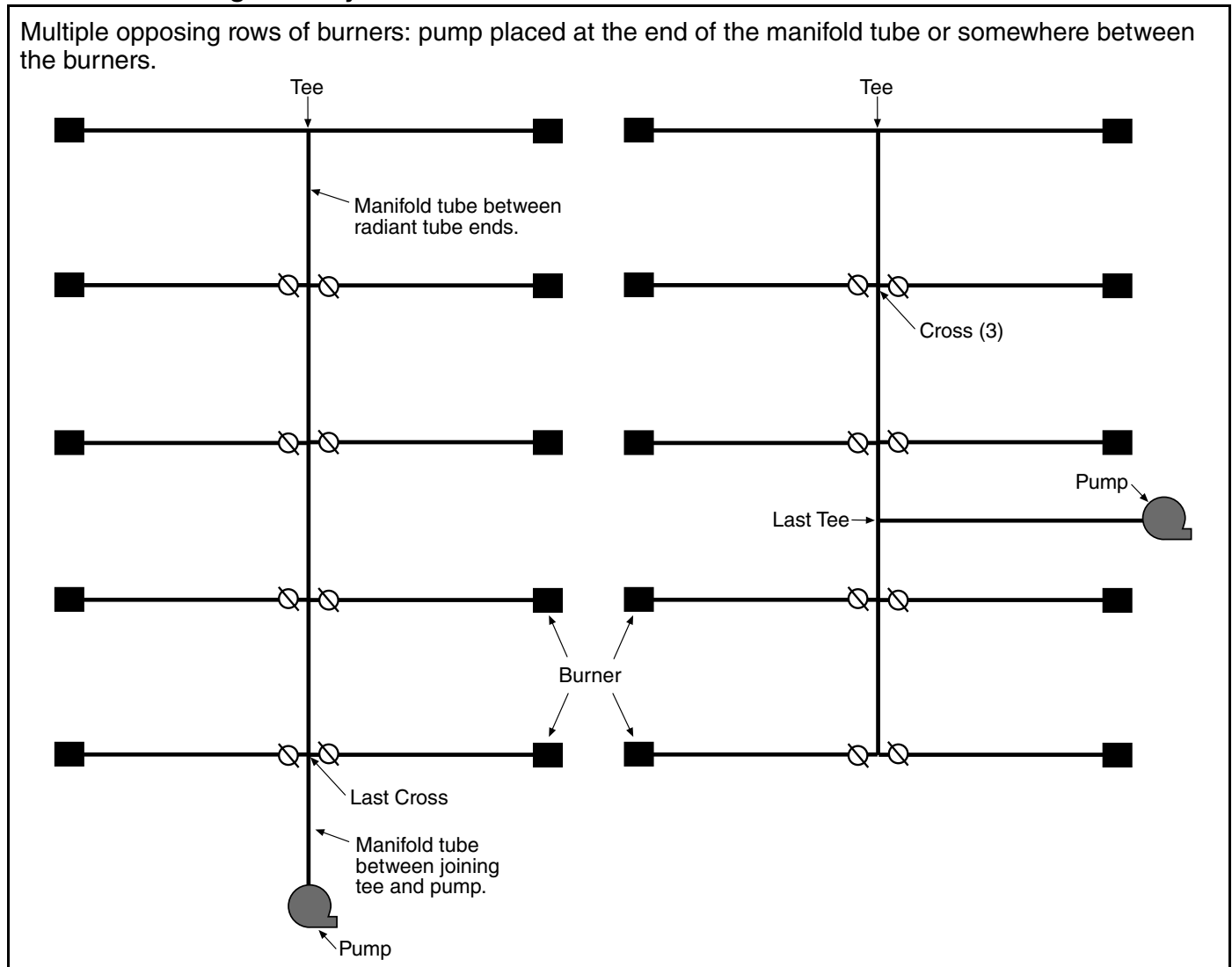

Step 9.7 Burner Tube Installation

NOTE:
Tubing requires a downward slope of 1/2" (1.3 cm) per 20' (6 m) away from burner.

S-hook
Hanger
Burner Tube
7' 6" ± 1'
(229 cm ± 25 cm)
Offset mounting hole must be to the top.
Weld seam must be to the bottom of the tube.

Description	Part Number
Burner Tube	03051XXX
S-Hook	91907302
Tube/Reflector Hanger	03090100

Step 9.8 Tube Clamp Package Installation

Description	Part Number
Tube Clamp Package	01318901
Tube Clamp	01396801
Bolt	97113940
Flat Washer	95211600
Nut	92113900

Tube Clamp
Bolt
Flat Washer
Nut
(Torque 120 in/lb
13.56 Nm)

Step 9.9 Coupling and Tube Assembly

A Close coupling with tab.

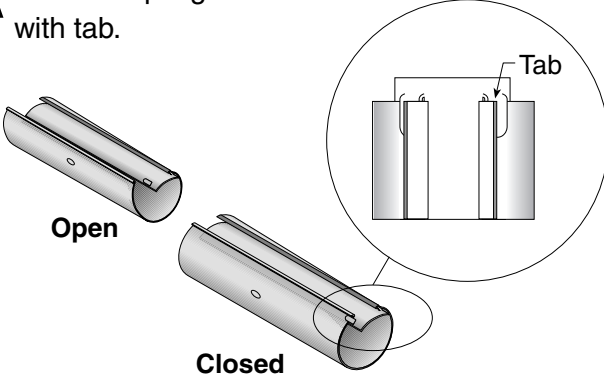

B Start slide bar/coupling lock onto coupling.

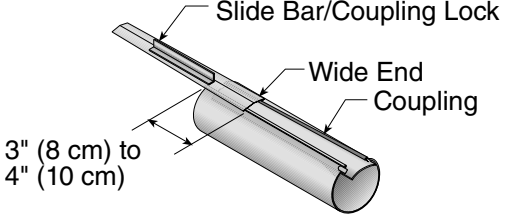

C Insert tubes into coupling.

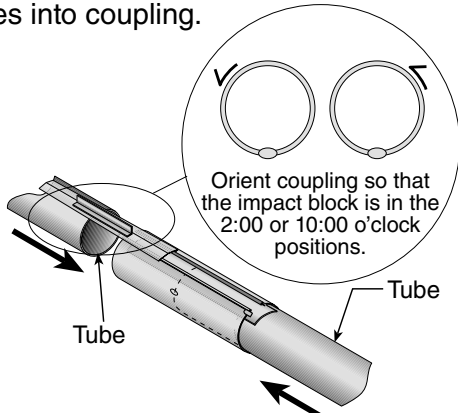

Orient coupling so that the impact block is in the 2:00 or 10:00 o'clock positions.

D Tighten coupling to join tubes.

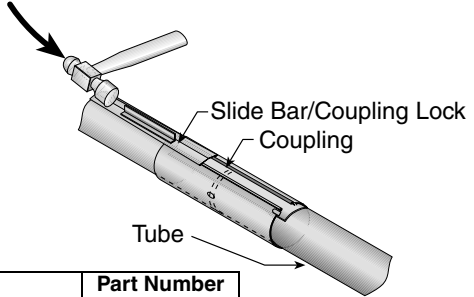

Description	Part Number
Coupling	01329600
Slide Bar/Coupling Lock	01329700
Tube	91409XXX

Step 9.9.1 Coupling and Tube Assembly (Continued)

Tighten slide bar as shown below.

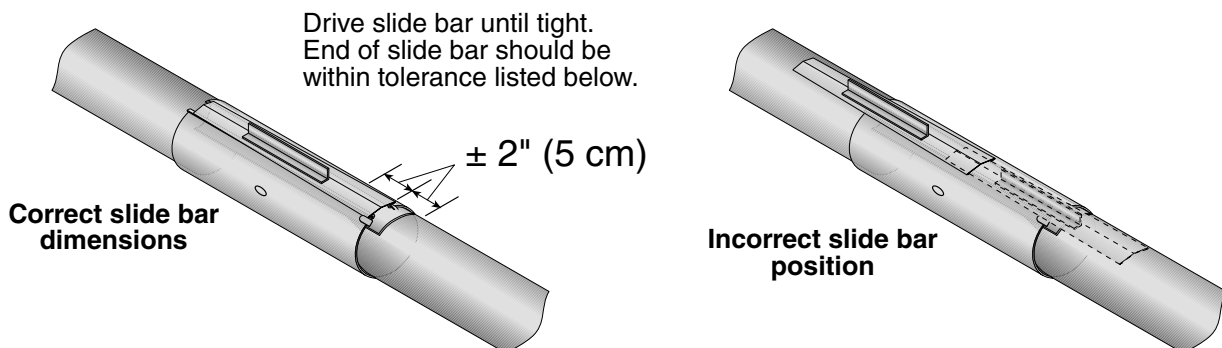

- Repeat Step 9.9 on Page 41, A - D until all tubes are assembled. See Page 42, Step 9.9.2.
- NOTE:** If coupling is not tight, loss of vacuum can occur.

Step 9.9.2 Coupling and Tube Assembly (Continued)

Model	Radiant Tube Length
CTHN-40	10' (3 m)
CTHN-60	20' (6 m)
CTHN-80	20' (6 m)
CTHN-100	30' (9 m)
CTHN-125	40' (12 m)
CTHN-150	40' (12 m)
CTHN-175	50' (18 m)
CTHN-200	50' (18 m)

Step 9.10 Turbulator Installation

Turbulator must be installed in the last standard section of radiant tube. Turbulator is only required on the CTHN-40, CTHN-60 and CTHN-80.

Turbulator Installation	
Model	Tube Section
CTHN-40	1st 10' (3 m) Section
CTHN-60	2nd 10' (3 m) Section
CTHN-80	2nd 10' (3 m) Section
CTHN-100	N/A
CTHN-125	N/A
CTHN-150	N/A
CTHN-175	N/A
CTHN-200	N/A

Description	Part Number
Turbulator Adapter	03051503
Turbulator Section	03051504
Turbulator Section (Stainless)	03051505
Tube	91409XXX

Turbulator section (stainless) used in CTHN-40 heaters must be in the section of tube nearest to the burner.

Fold tab around outside of tube nearest to the vent to hold turbulator in place.

Step 9.11 Reflector Installation

⚠ WARNING**Fire Hazard**

Support reflector with reflector hanger and support strap.

Reflector must not touch tube.

Failure to follow these instructions can result in death, injury or property damage.

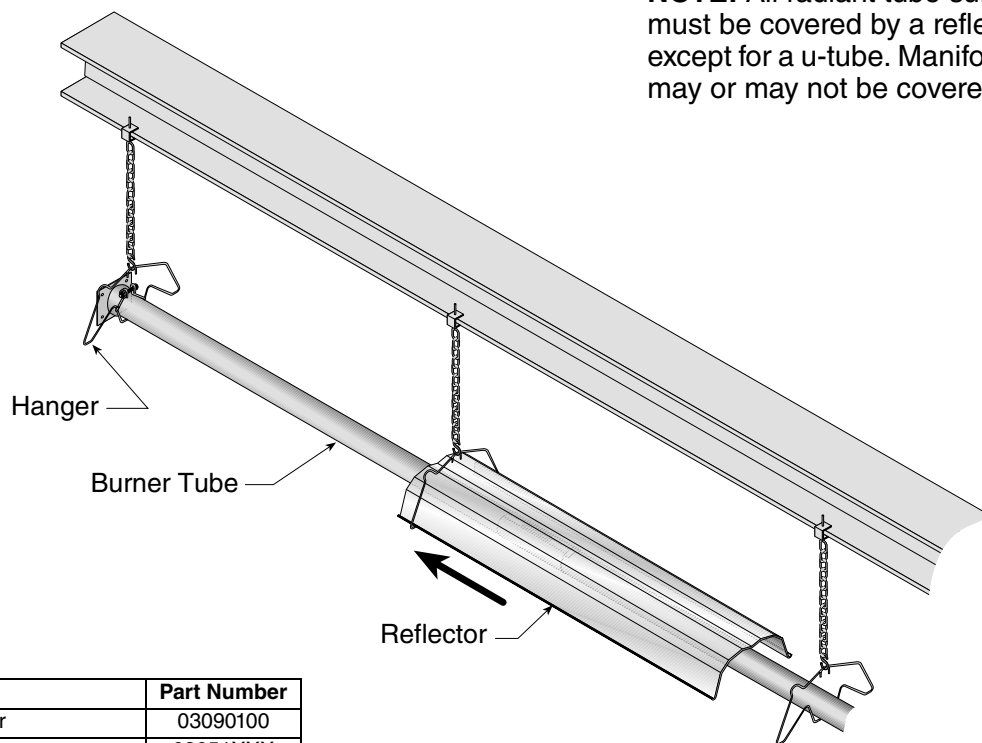

NOTE: All radiant tube surfaces must be covered by a reflector, except for a u-tube. Manifold tube may or may not be covered.

Description	Part Number
Tube/Reflector Hanger	03090100
Burner Tube	03051XXX
Reflector	02750303

Step 9.11.1 Reflector, U-clip and Reflector Support Installation

The pictorial drawings of the heater construction in Section 9 are schematic only and provide a general guideline of where hangers, reflector supports and u-clips are to be installed.

To ensure proper expansion and contraction movement of the reflectors, a combination of u-clips and reflector supports are used. The positioning of

reflector supports and u-clips depend on the individual installation. Use either pop rivets or sheet metal screws instead of u-clips when installing end caps and joint pieces in areas where impact and high wind may be a factor. The following rules must be observed.

1. The first reflector after the burner must be affixed in the middle of the reflector with a reflector support and tight screws.

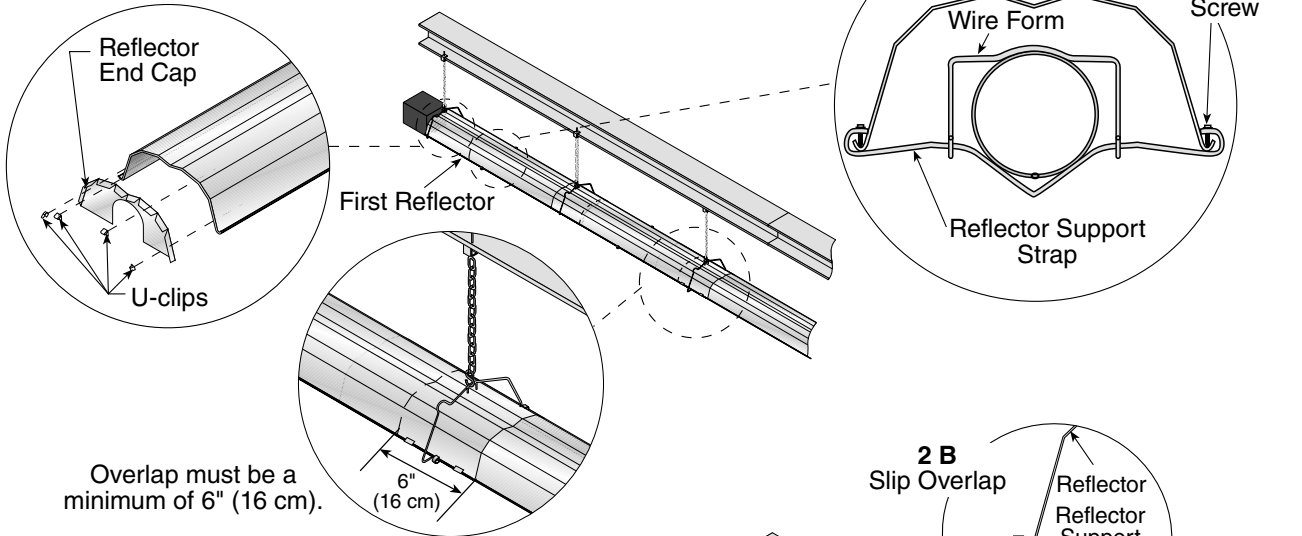

2. The overlap at the first and second reflector is a **slip overlap**. Thereafter, every third reflector joint is a slip overlap. A slip overlap is achieved by either:
 - a.) both reflectors lay inside a hanger. (No reflector support needed.)
 - b.) using a reflector support with loose screws at the reflector overlap.

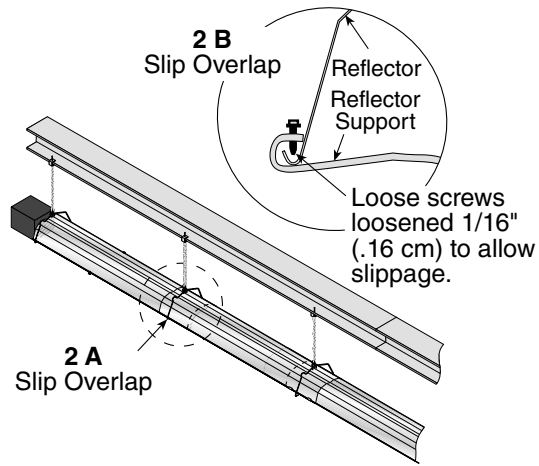

3. The remaining reflector overlaps require a **non-slip overlap** connection. To affix the reflectors together in a non-slip overlap either:
 - a.) use reflector support and tight screws.
 - b.) if both reflectors lay inside a hanger, u-clips or sheet metal screws may be used.

This section of three reflectors joined together must be affixed to the tube with at least one reflector support with tight screws.

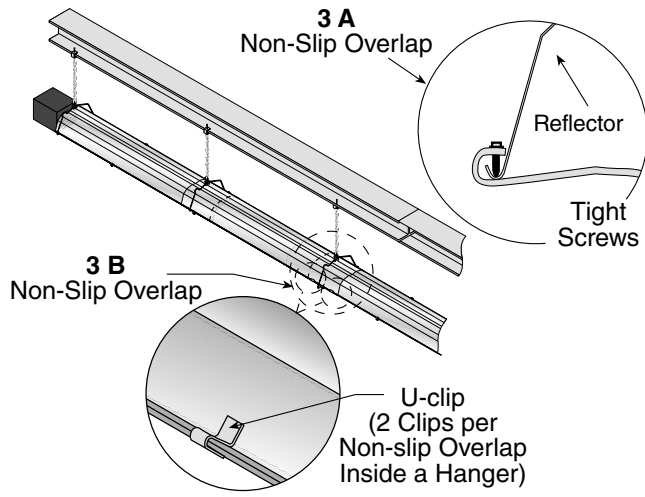

Description	Part Number
Reflector Support Package	03050010
Wire Form	91908004
Reflector Support Strap	03050000
Screw #8 x 3/4	94320812
U-clip Package	91107720
Reflector End Cap	027508XX

Step 9.12 Burner Installation

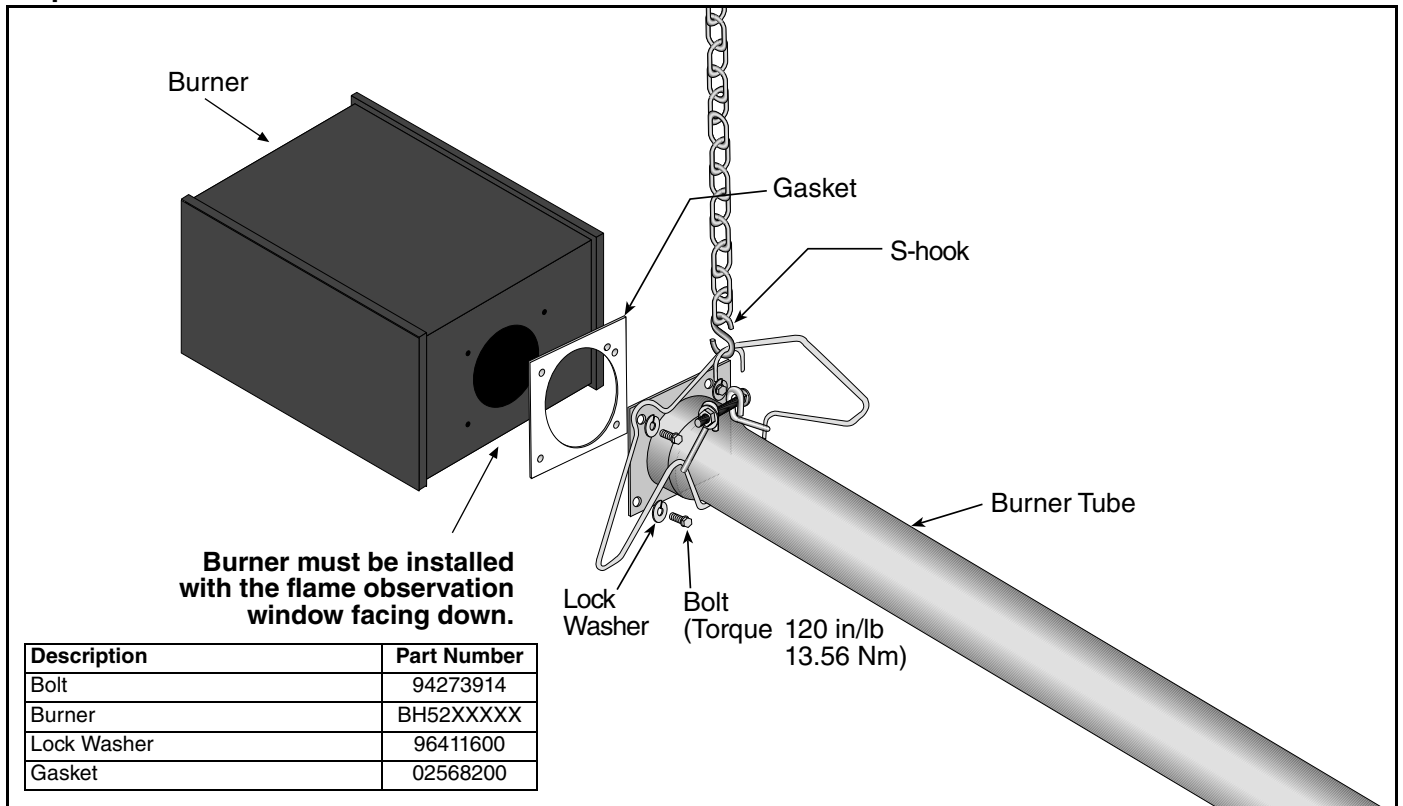

SECTION 10: OPTIONAL HEATER ACCESSORIES

⚠ WARNING



Cut/Pinch Hazard

Wear protective gear during installation, operation and service.

Edges are sharp.

Failure to follow these instructions can result in injury.

10.1 Elbow Package Configuration

Step 10.1.1 Elbow Installation

Description	Part Number
Elbow Package	02718702
90° Elbow	01335801
Coupling	01312700
Reflector End Cap	02750800
Reflector Joint Piece	02750900
U-Clip Package	91107720

Minimum Distance Required Between Burner and Elbow	
Model	Minimum Distance
CTHN-40	10' (3 m)
CTHN-60	10' (3 m)
CTHN-80	10' (3 m)
CTHN-100	15' (4.5 m)
CTHN-125	15' (4.5 m)
CTHN-150	20' (6 m)
CTHN-175	20' (6 m)
CTHN-200	20' (6 m)

Step 10.1.2 Elbow Installation

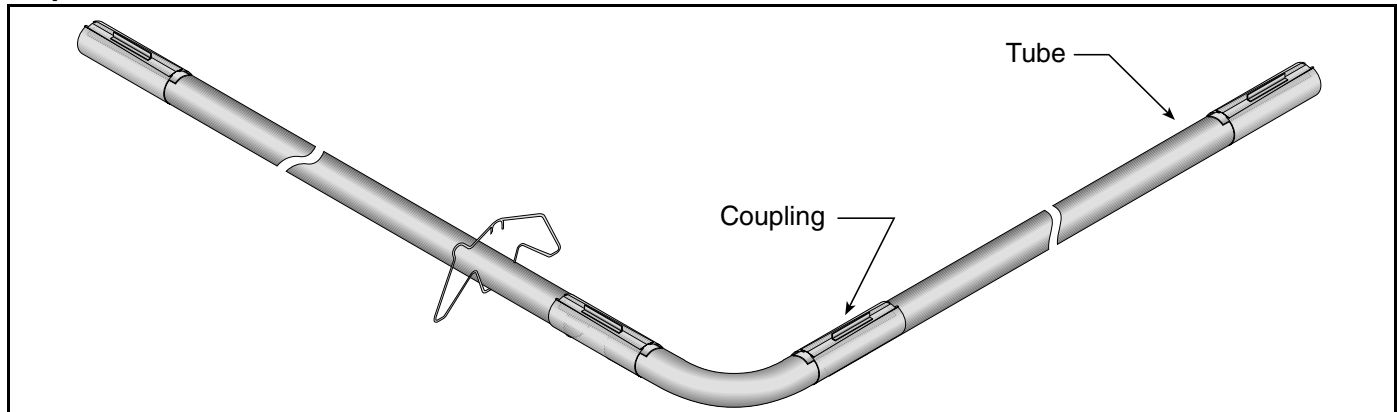

Step 10.1.3 Reflector Joint Installation

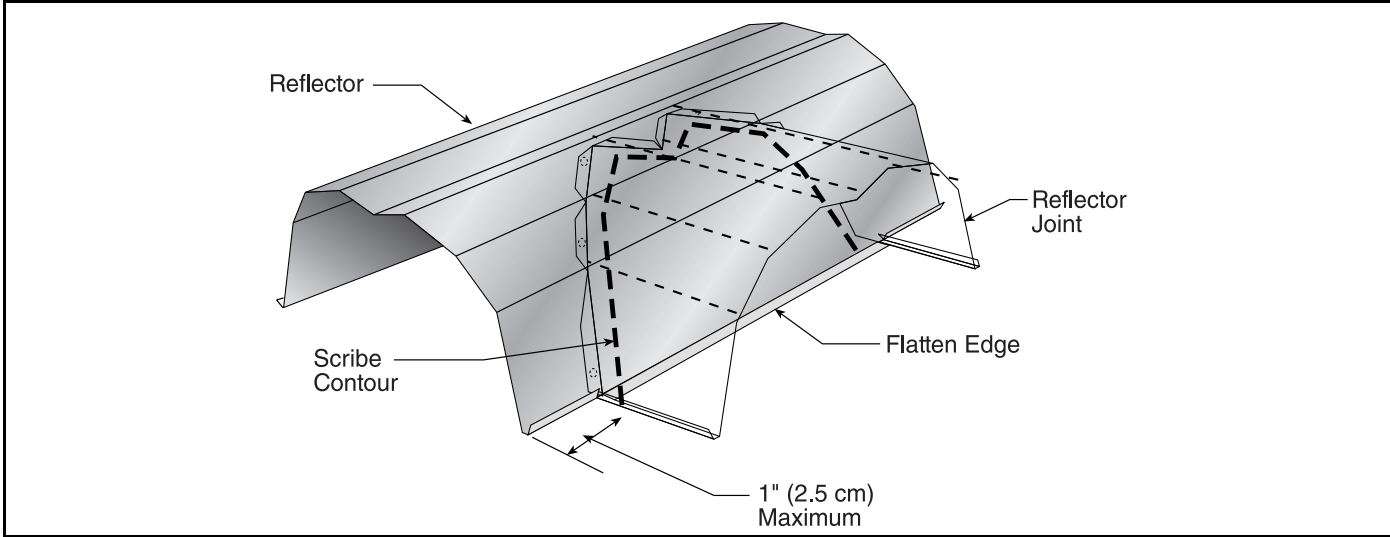

Step 10.1.4 Reflector Joint Installation

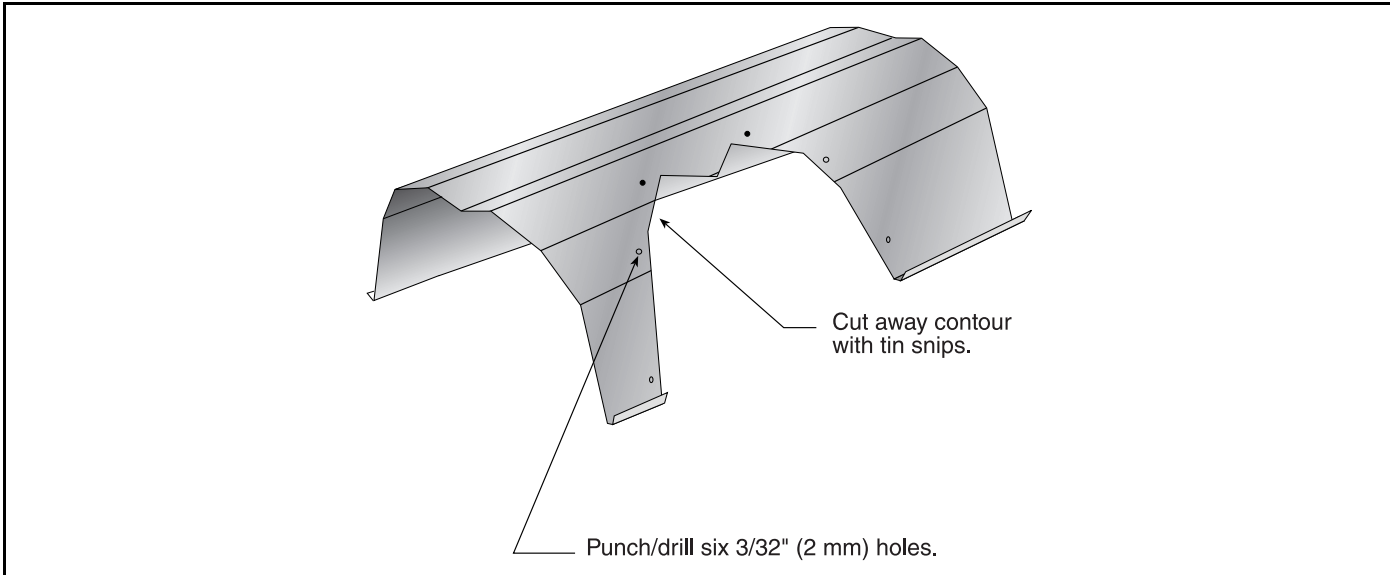

Step 10.1.5 Reflector Joint Detail

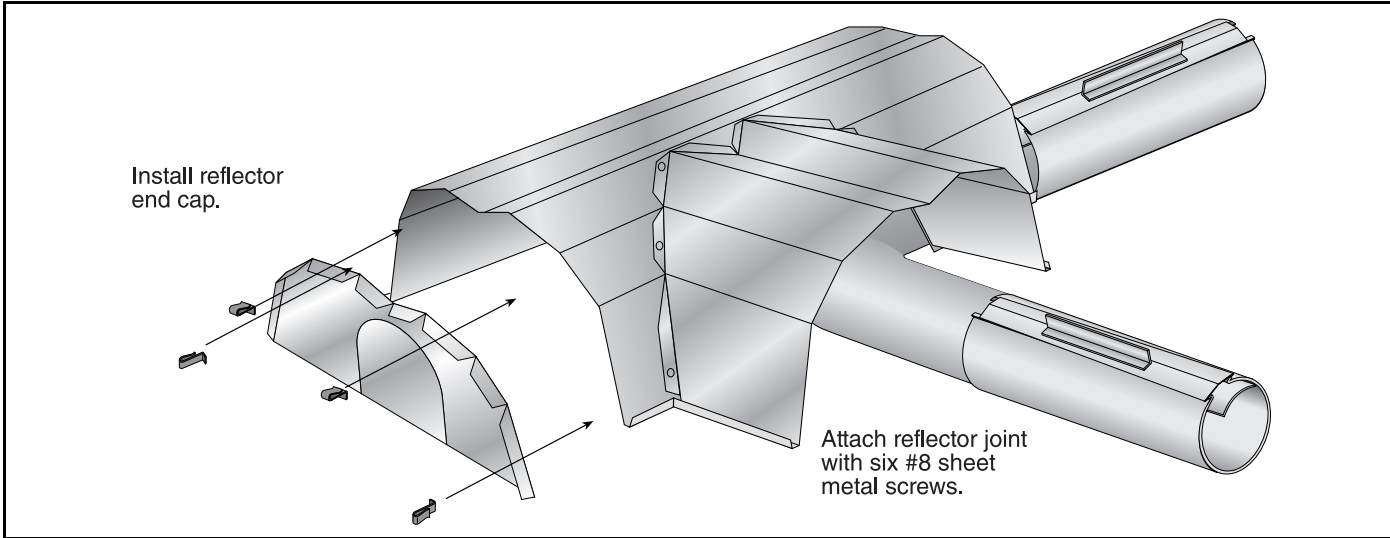
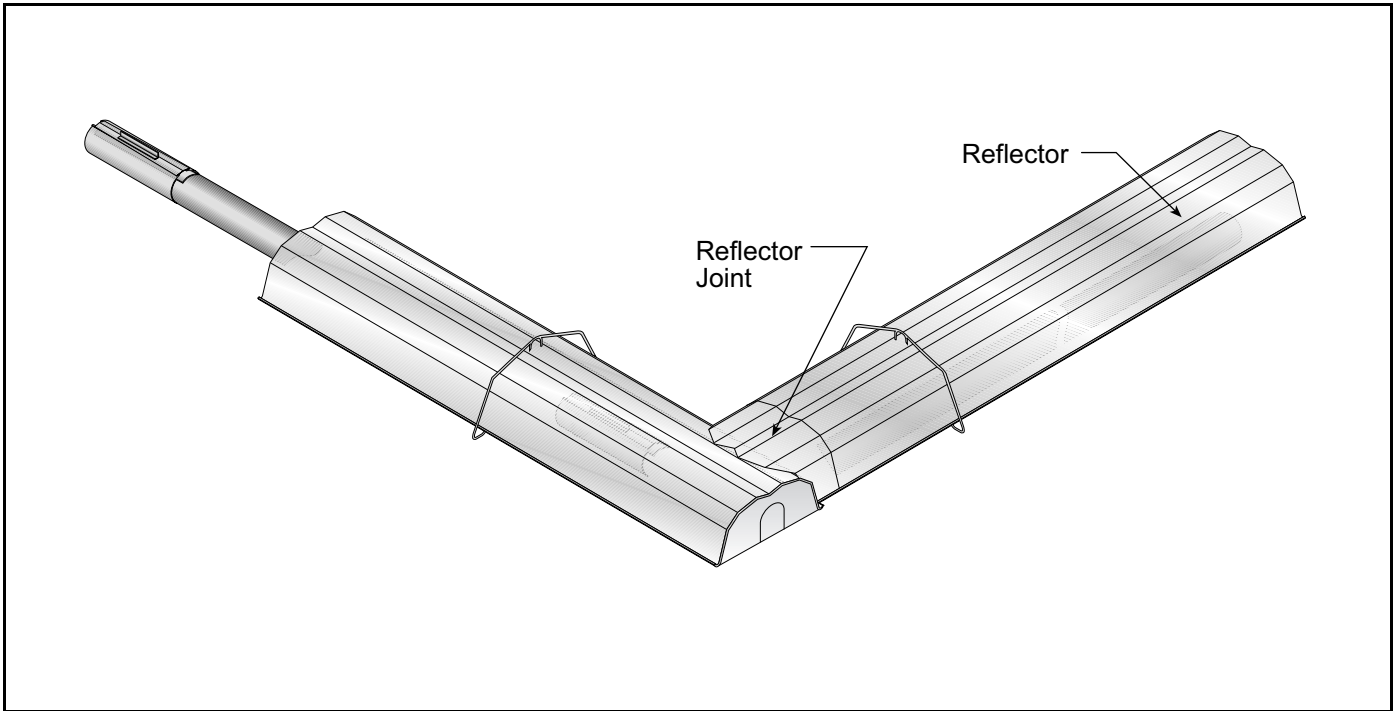
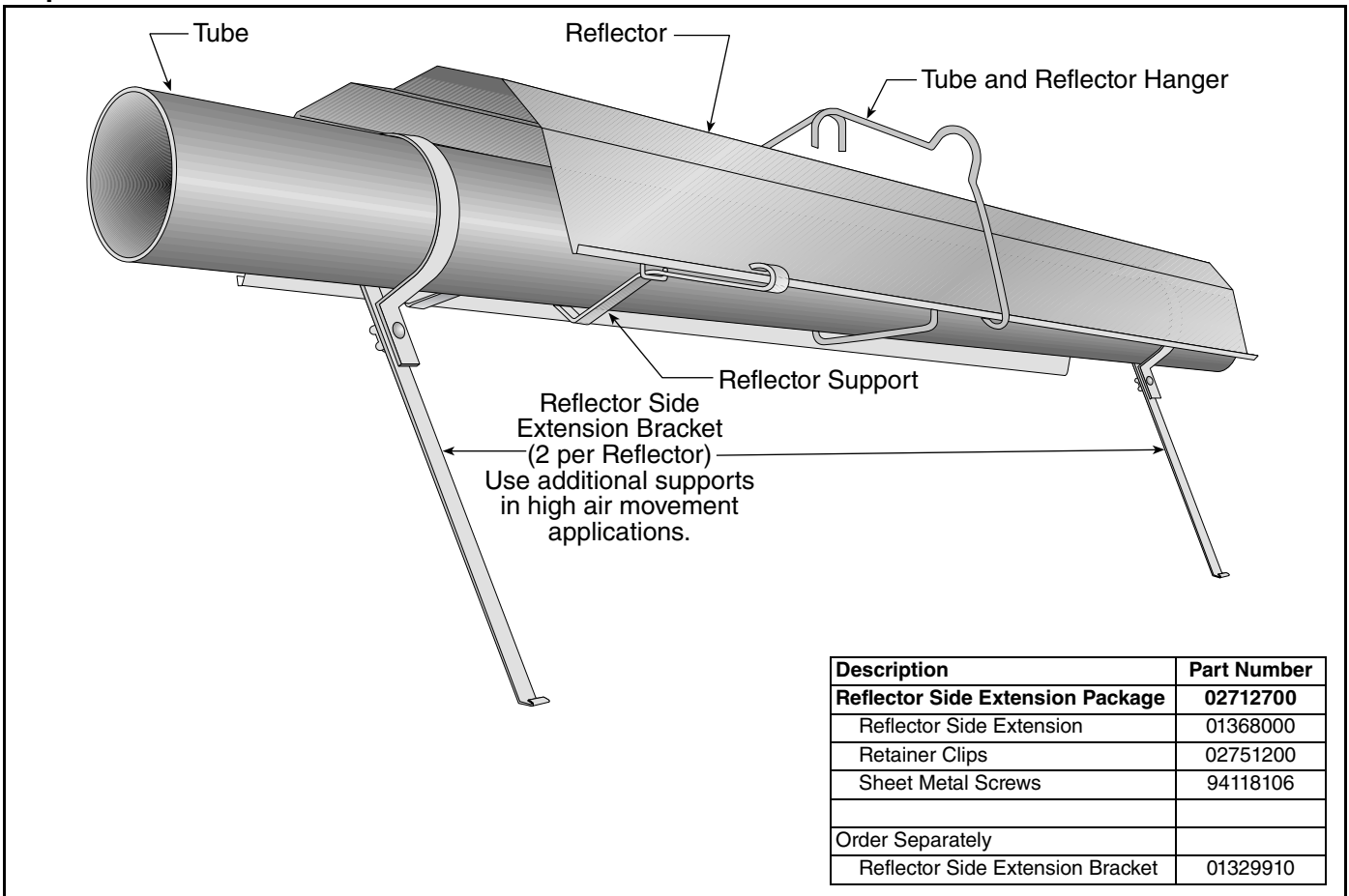

FIGURE 26: Reflector Joint Detail



10.2 Reflector Side Extension

Step 10.2.1 Bracket Installation



Step 10.2.2 Side Reflector Installation

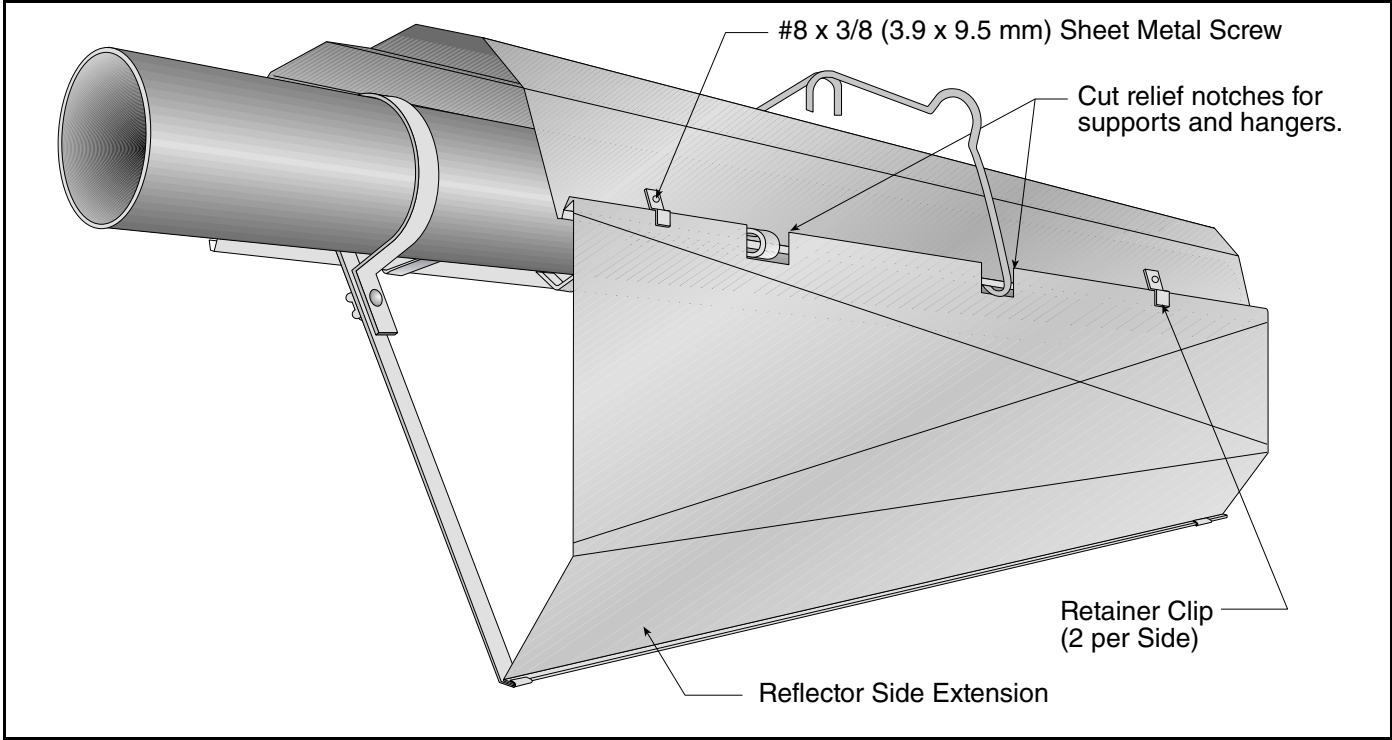

10.3 Lower Clearance Shield Installation

Step 10.3.1 Shield Support Strap Assembly

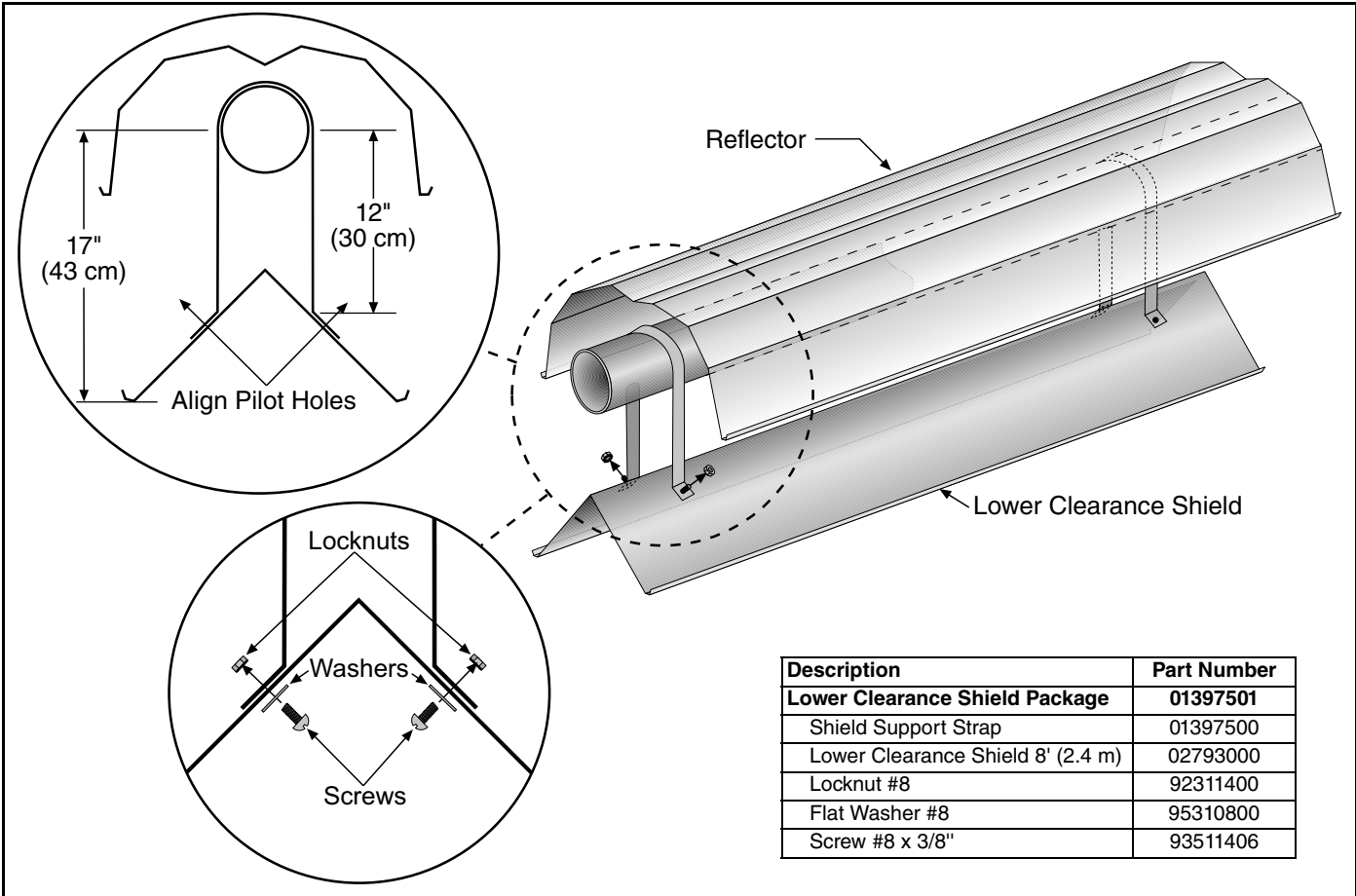

Description	Part Number
Lower Clearance Shield Package	01397501
Shield Support Strap	01397500
Lower Clearance Shield 8' (2.4 m)	02793000
Locknut #8	92311400
Flat Washer #8	95310800
Screw #8 x 3/8"	93511406

10.4 Two-Foot Decorative Grille Installation

Step 10.4.1 Grille Installation

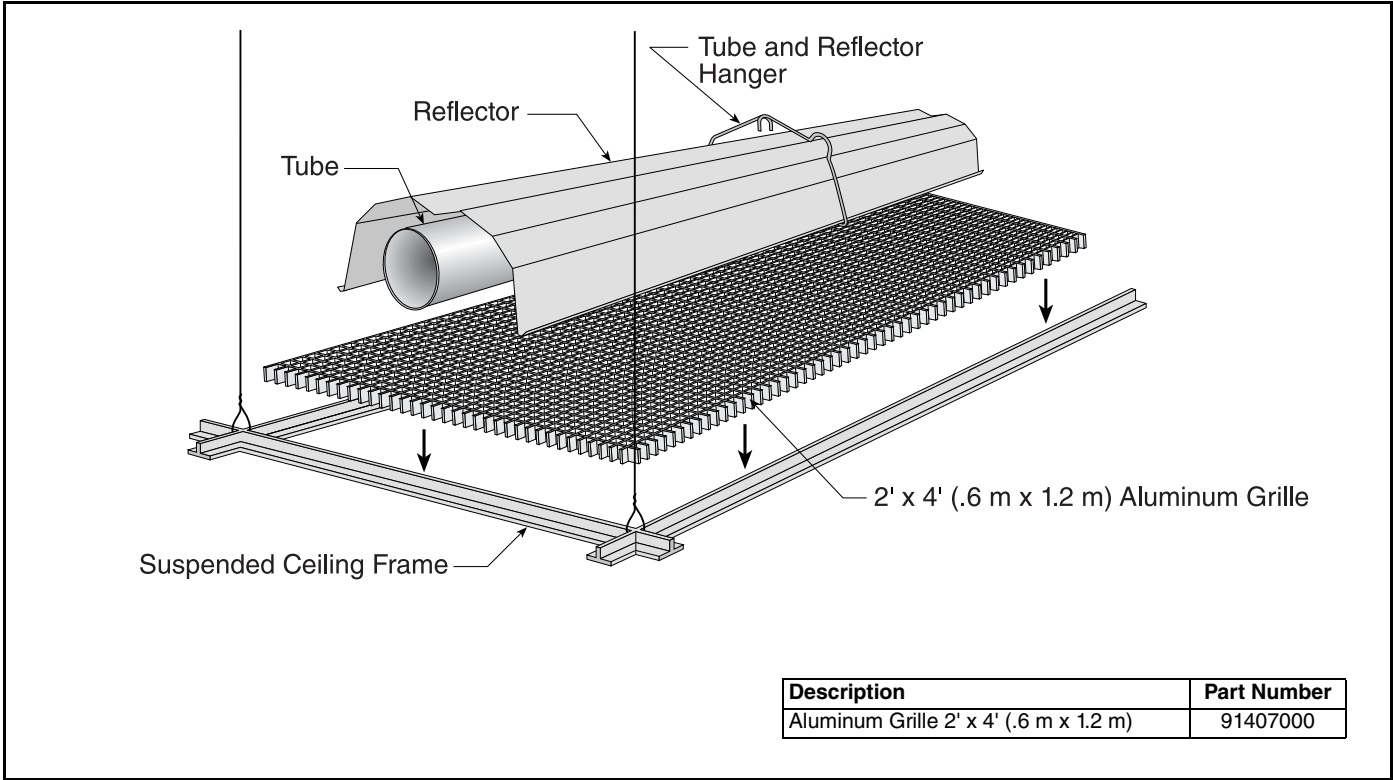

Step 10.4.2 Frame Shield Installation

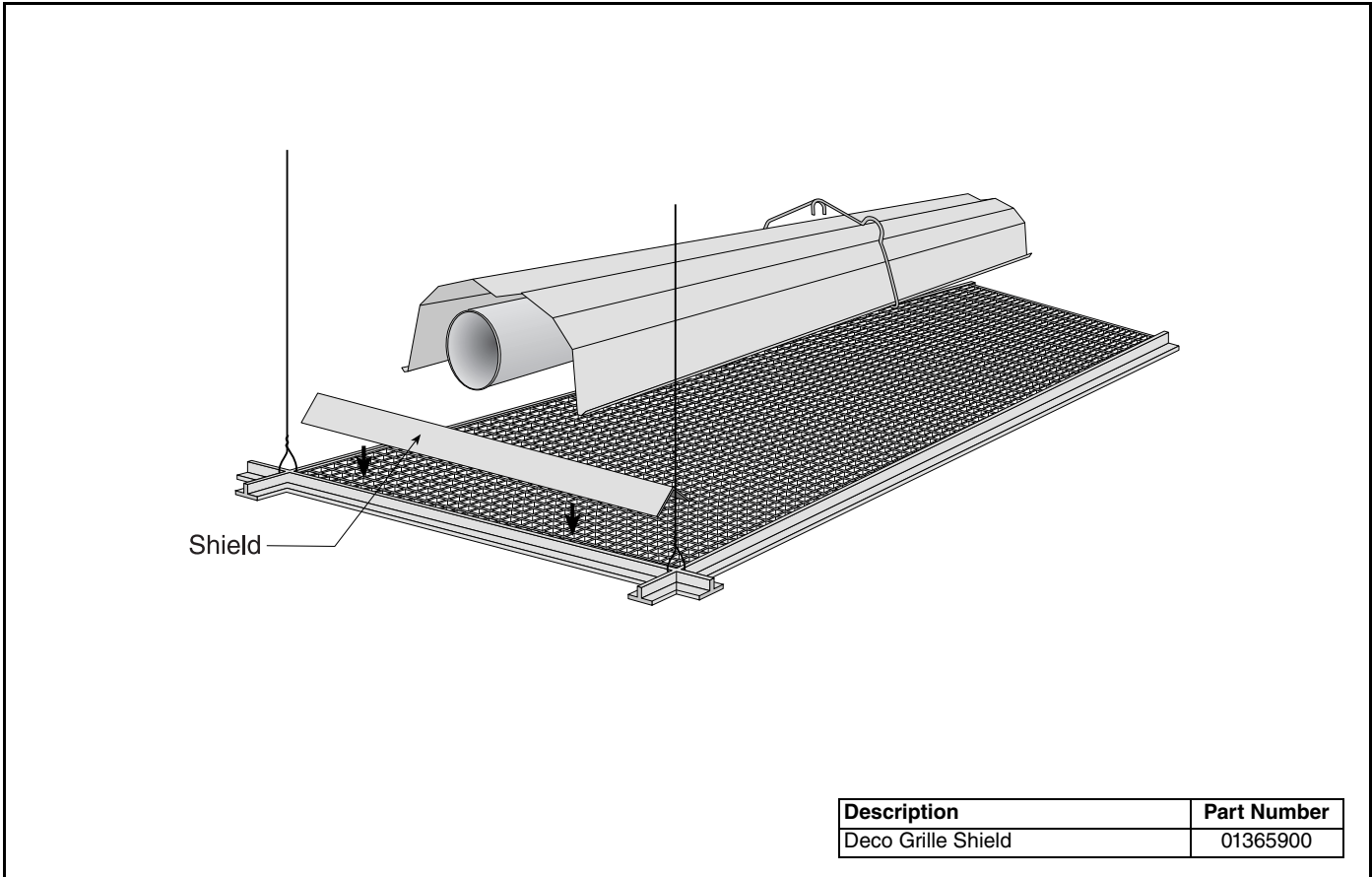

Step 10.4.3 Reflector Side Extension Installation for Decorative Grilles

NOTE: If the decorative grille system is to be installed in an area with considerable air movement, it is recommended that one #8 x 3/8" sheet metal screw be installed per reflector extension to prevent it from blowing over.

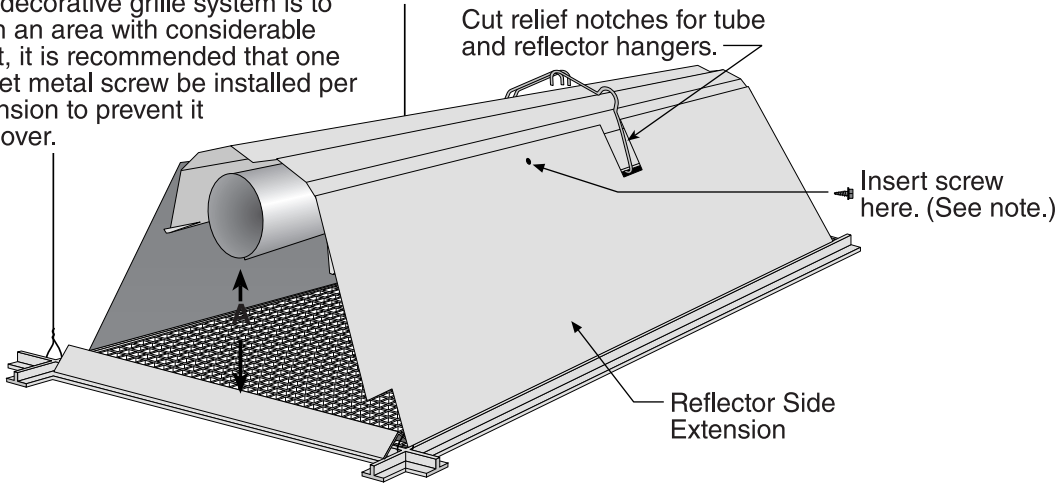

Distance "A"		Extension	
Minimum	Maximum	Part No.	Width
2" (4 cm)	6" (15 cm)	01370408	8" (20 cm)
6" (15 cm)	10" (26 cm)	01370412	12" (30 cm)
10" (26 cm)	14" (37 cm)	01370416	16" (40 cm)

Description	Part Number
Reflector Side Extension	01370412

10.5 Protective Grille Installation

Step 10.5.1 Silicone Cap Installation

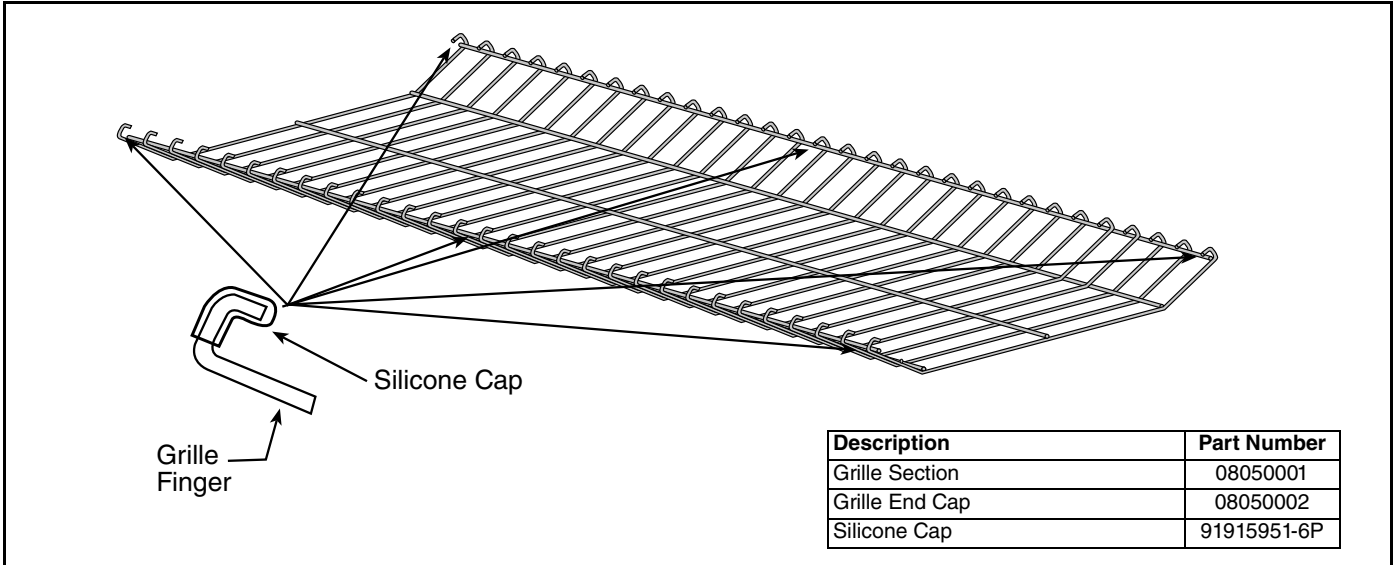

Step 10.5.2 Grille End Cap Installation

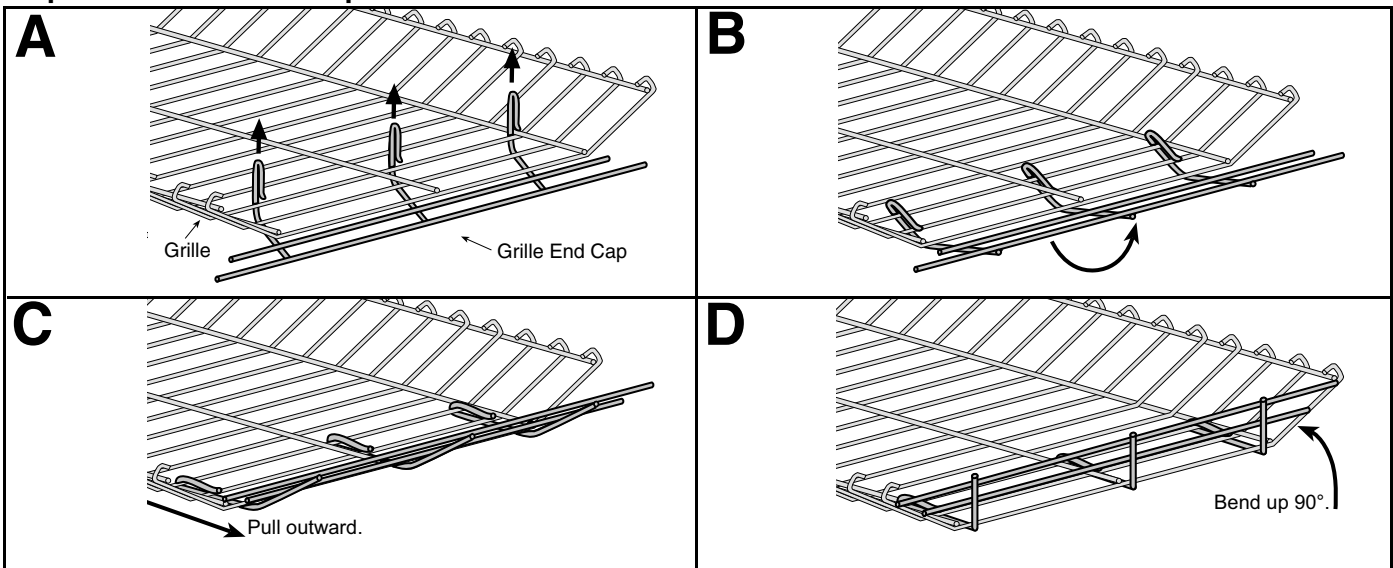

Step 10.5.3 Grille Installation

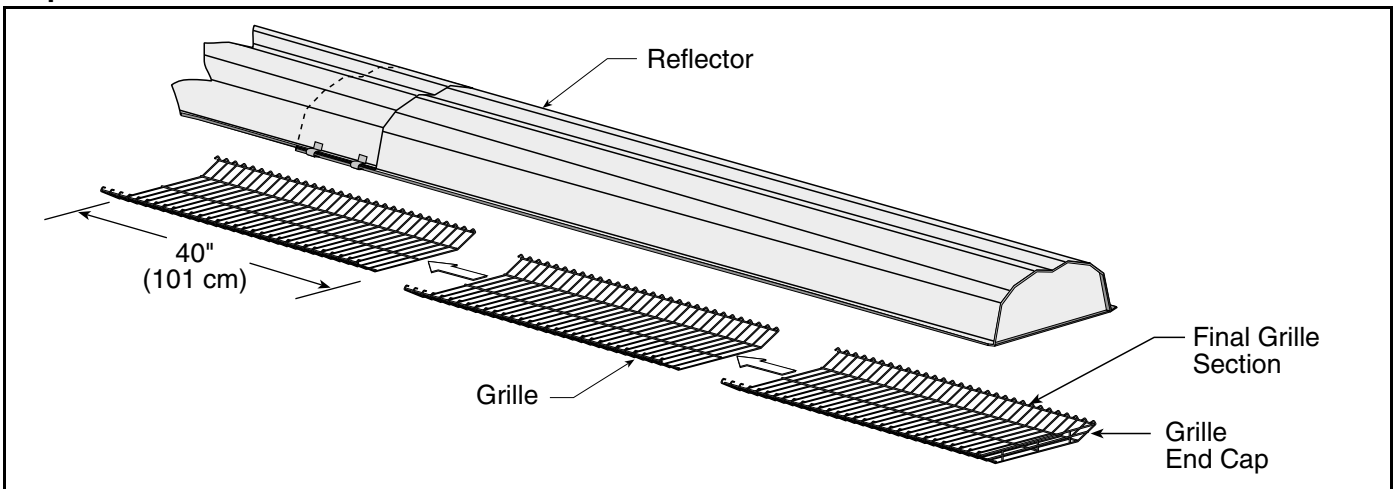

SECTION 11: VENTING - GENERAL**! WARNING****Carbon Monoxide Hazard**

Multiburner systems are not approved for unvented use and must be vented outdoors.

Unitary heaters installed unvented must be interlocked with sufficient building exhaust.

Heaters must be installed according to the installation manual.

Failure to follow these instructions can result in death or injury.

! WARNING**Cut/Pinch Hazard**

Wear protective gear during installation, operation and service.

Edges are sharp.

Failure to follow these instructions can result in injury.

11.1 General Venting Requirements

This heater must be vented in accordance with the rules contained in this manual and with the following national codes and any state, provincial or local codes which may apply:

United States: Refer to National Fuel Gas Code NFPA 54/ANSI Z223.1 - latest revision.

Canada: Refer to Natural Gas and Propane Installation Code CSA B149.1 - latest revision.

Any portion of vent pipe passing through a combustible wall must have an approved thimble to conform with the above listed codes.

Vent pipe must be sloped downward away from the heater 1/2" (1 cm) for every 20' (6 m).

The bottom of the vent or air intake terminal shall not be located less than 1' (0.3 m) above grade level.

The vent shall not terminate less than 7' (2.1 m) above grade where located adjacent to public walkways.

Vent terminal must be installed at a height sufficient to prevent blockage by snow and building materials protected from degradation by flue gases.

Secure all joints with #8 x 3/8 sheet metal screws. Seal all joints with high temperature silicone sealant.

Vent terminal must be beyond any combustible overhang.

For vertical venting, vent shall not extend less than 2' (0.6 m) above the highest point where it passes through a flat roof of a building.

11.1.1 United States Requirements

Vent must terminate at least 3' (0.9 m) above any forced air inlet located within 10' (3.1 m).

Vent must terminate at least 4' (1.2 m) below, 4' (1.2 m) horizontally from, or 1' (0.3 m) above any door, operable window, or gravity air inlet into any building.

11.1.2 Canadian Requirements

The vent shall not terminate within 6' (1.8 m) of a mechanical air supply inlet to any building.

The vent shall not terminate within 3' (0.9 m) of a window or door that can be opened in any building, any non-mechanical air supply inlet to any building, or of the combustion air inlet of any other appliance.

SECTION 12: VENTING - UNITARY HEATER

All general venting requirements apply.

See Page 53, Section 11.

Exhaust end of fan will accept a 4" (10 cm) vent pipe. To prevent leakage of condensation, seal all the vent joints using a high temperature silicone sealant.

The heater may be individually vented or common vented. When venting horizontally, a maximum of two heaters can be commonly vented. See Page 56, Section 12.9. When venting vertically, a maximum of four heaters can be commonly vented. See Page 57, Section 12.10.

The CTHN unitary heater may also be installed unvented in certain circumstances according to building ventilation codes. Refer to the codes on Page 53, Section 11.1 and Page 54, Section 12.1 for further information. Unvented operation also requires compliance with the clearances to combustibles given on Page 8, Figure 12.

12.1 Unvented Operation

Sufficient ventilation must be provided in the amount of 4 cfm per 1000 Btu/h firing rate (United States); 3 cfm per 1000 Btu/h firing rate (Canada).

Use of optional outside combustion air is not recommended with unvented heaters.

If exhaust fans are used to supply ventilation air, an interlock switch must be used to prevent the heater from coming on when the fans are off. This may be done using a pressure switch.

12.2 Unvented Operation Termination

For unvented operation, turndown type vent terminal with a screen must be installed at the exhaust end of the fan. Vent terminal design shall not incorporate backdraft flap.

FIGURE 27: Fan Termination

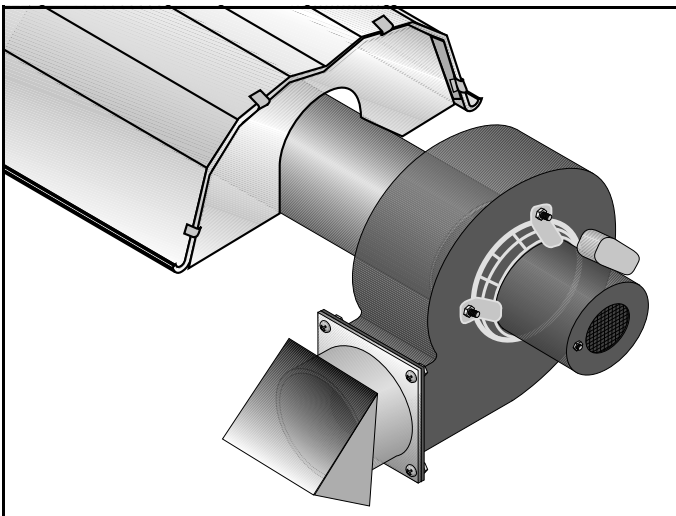

12.3 Horizontal Venting

In noncombustible walls only, vent terminal (P/N 02537801-1P) may be used.

For 4" (10 cm) vents in either combustible or noncombustible walls, use Tjernlund VH1-4 (P/N 90502100) or equivalent, insulated vent terminal. Follow the manufacturer's instructions for proper installation.

For 6" (15 cm) common vents in either combustible or noncombustible walls, use Tjernlund VH1-6 (P/N 90502101) or equivalent, insulated vent terminal. Follow the manufacturer's instructions for proper installation.

12.4 Vertical Venting

For 4" (10 cm), an approved vent cap (P/N 90502300) must be used.

For 6" (15 cm) common vent, an approved vent cap (P/N 90502302) must be used.

For common vertical venting of more than two heaters, See Page 57, Section 12.10.

12.5 Length Requirements

The maximum vent length allowed is 45' (13.7 m). The maximum outside air supply duct length allowed is 45' (13.7 m).

The total vent length, plus outside air duct length and any extensions to minimum heat exchanger lengths, cannot exceed 65' (19.8 m).

Vent length should be limited to less than 20' (6 m). If using extended heater lengths or vent lengths greater than 20' (6 m), condensation will form in the vent pipe. Insulation and additional sealing measures (high temperature silicone at all seams) are required. Optional heat exchanger beyond minimum lengths is considered as vent length for length determination. Subtract 15' (4.6 m) of maximum allowed vent or duct length per vent elbow if more than two are used.

12.6 Flue Connection Detail

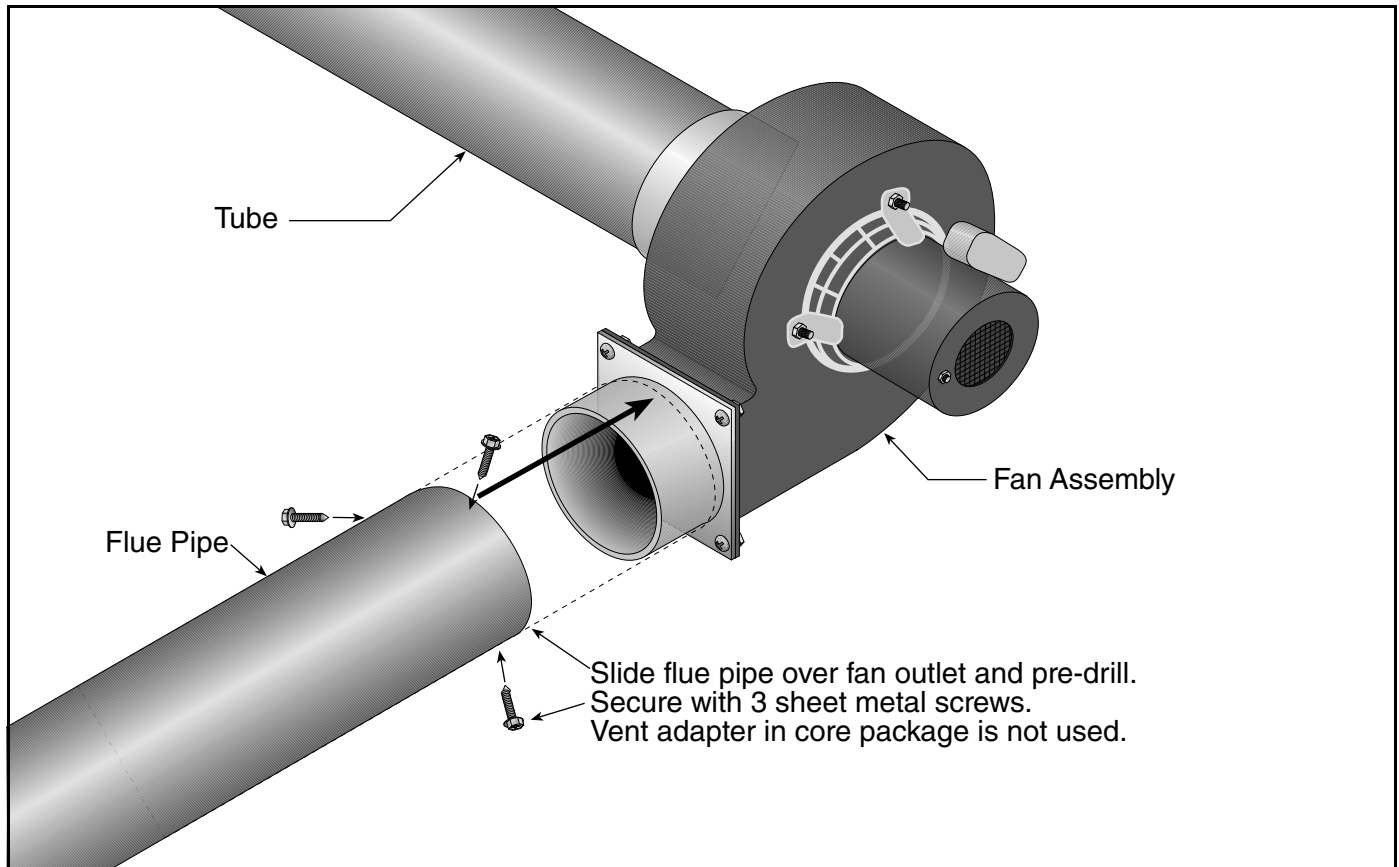

12.7 Horizontal Ventilation 4" (10 cm) Pipe

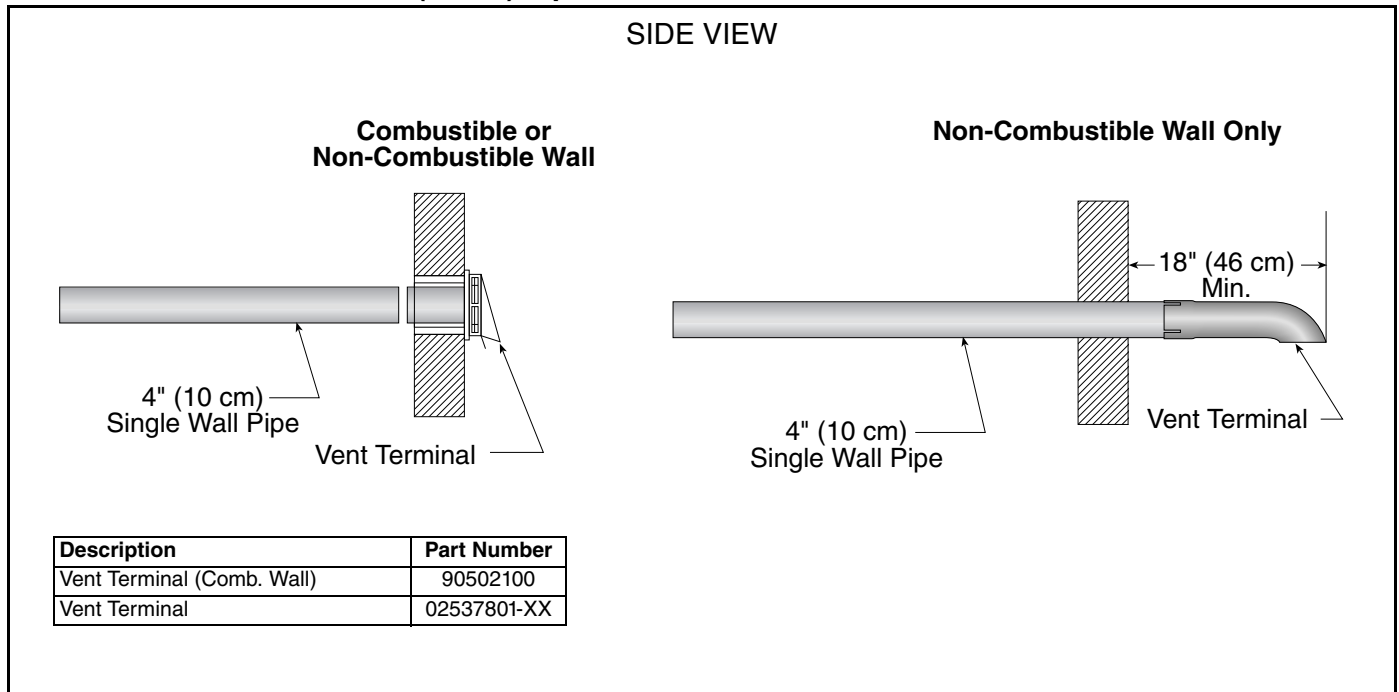

12.8 Vertical Ventilation 4" (10 cm) Pipe

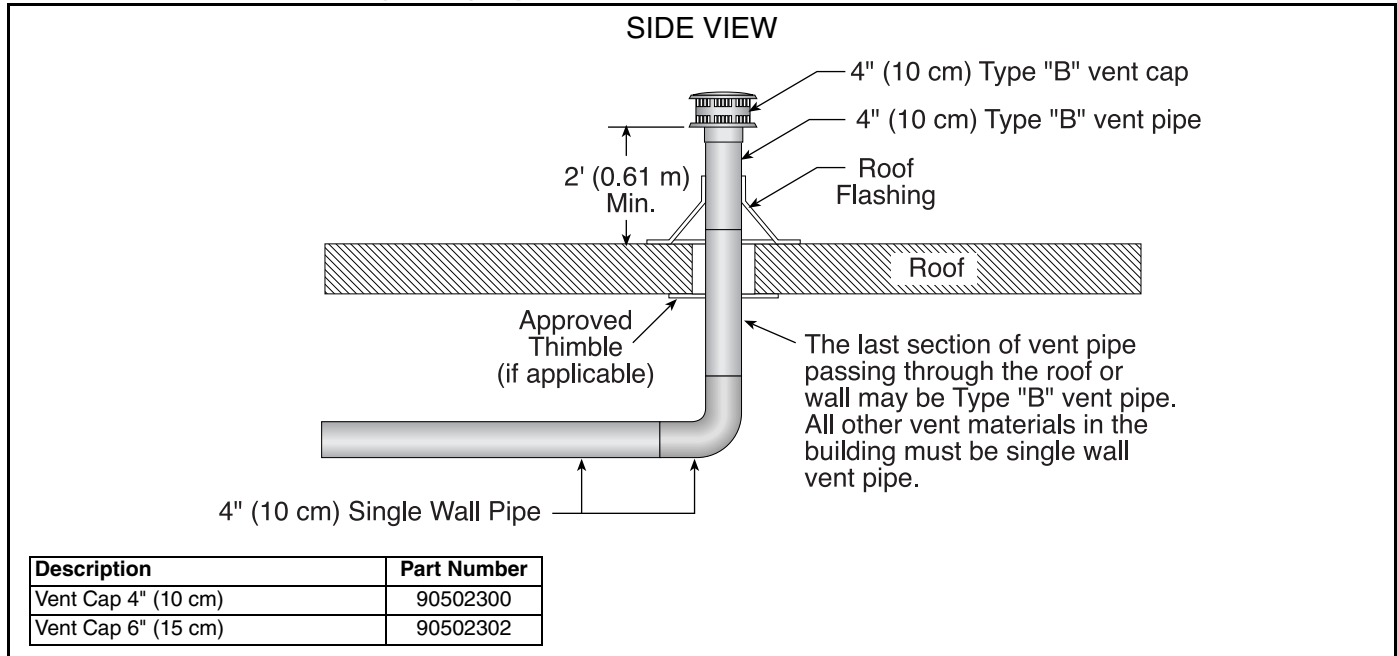

12.9 Common Side Wall Venting

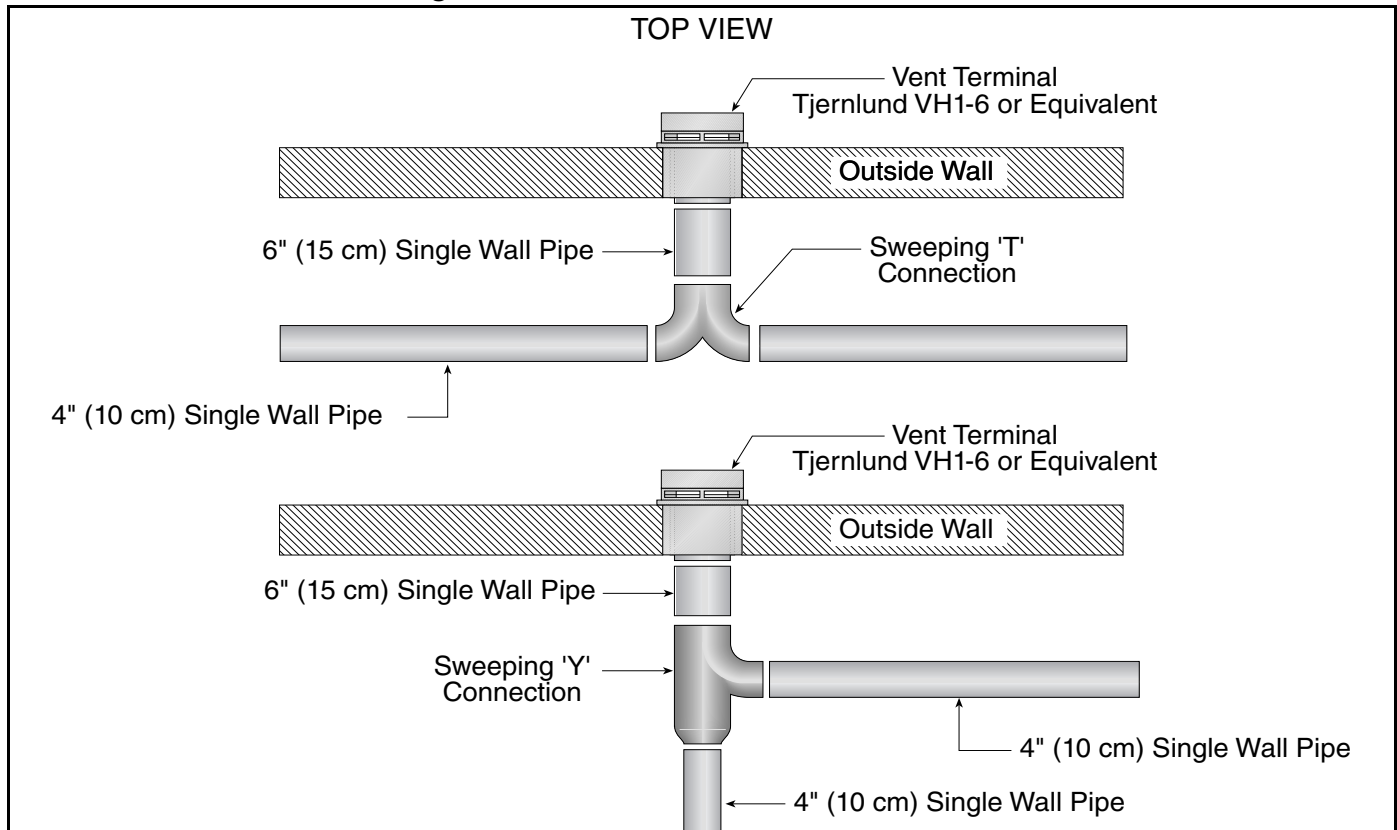

Requirements:

- Maximum of 2 heaters can be commonly vented through a side wall.
- Heaters must be of the same BTU output.
- Heaters must be controlled by a common thermostat.

12.10 Common Vertical Venting

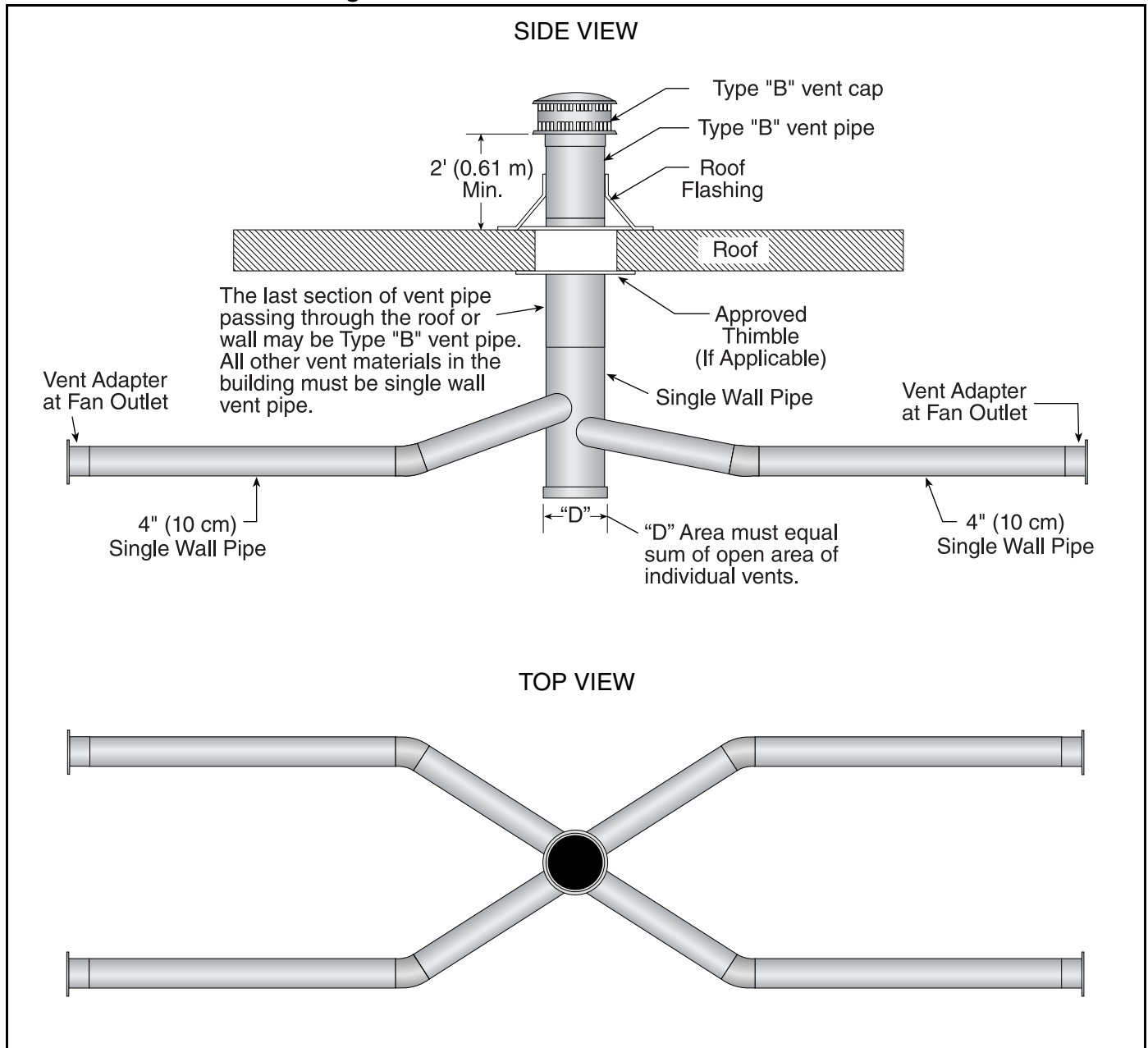

Requirements:

- Maximum of 4 heaters can be commonly vented through the roof.
- Heaters must be of the same BTU output.
- Heaters must be controlled by a common thermostat.
- Connections to a common stack must be positioned to avoid direct opposition between streams of combustion gases.

SECTION 13: VENTING - MULTIBURNER SYSTEMS

13.1 General Requirements

See Page 53, Section 11.1. All general venting requirements apply.

! WARNING



Carbon Monoxide Hazard

Multiburner systems are not approved for unvented use and must be vented outdoors.

Vented heaters must be installed according to the installation manual.

Failure to follow these instructions can result in death or injury.

! WARNING



Cut/Pinch Hazard

Wear protective gear during installation, operation and service.

Edges are sharp.

Failure to follow these instructions can result in injury.

13.2 Manifold Tube Requirements

Manifold tube is used to connect radiant tubing to the pump. When more than one burner is connected to a pump, a special connection fitting is utilized, such as a cross or tee section. See Page 58, Figure 28. It is recommended that 4" (10.2 cm) O.D. or 6" (15.2 cm) O.D. aluminized or coated tubing be used for manifold pipe. Reflectors are not required, but may be used over 4" (10.2 cm) manifold pipe. Manifold pipe must be supported properly, with at least one hanger per 10' (3 m) section. Refer to Page 30, Section 9 for manifold length design requirements.

13.3 Venting the Pump

The exhaust connection from the pump is 4" (10.2 cm) or 6" (15.2 cm) diameter. Connect one of the flexible isolation boots provided to the flue pipe. Connections to the flue pipe larger than the pump outlet diameter will require the use of an appropriate adapter (not supplied).

Venting from the pump may discharge either horizontally or vertically; corrosion resistant pipe is required. See Page 60, Figure 30 for pump vent length requirements.

The layout drawing shows the general location of the pump. Specific pump location and discharge details must meet general venting requirements (see Page 53, Section 11 and Page 58, Section 13.1) as well as the following criteria:

- To avoid staining the building wall, extend discharge 3' (1 m) from the building if possible.
- Horizontal discharge is preferred, see Page 60, Figure 30. Vertical discharge must be arranged as shown. See Page 59, Figure 29.

If the vent pipe is over 20' (6 m) long, insulate it to minimize condensation. Seal all discharge pipe joints with high-temperature silicone or equivalent.

FIGURE 28: Tailpipe Connection Points

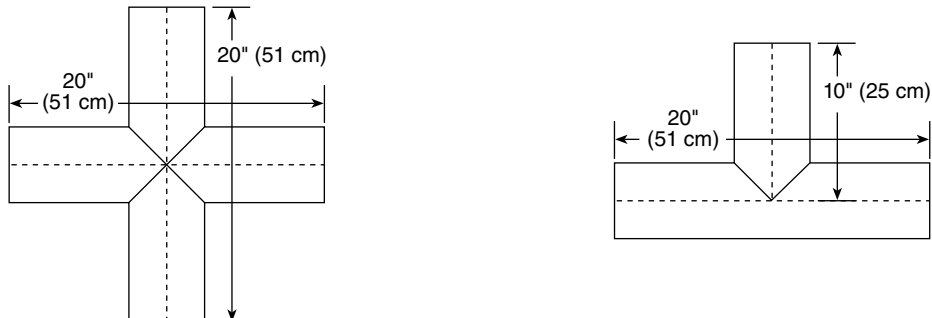

Description	Part Number
Porcelain Coated Cross, 4" (10.2 cm) dia	0133092D
Aluminized Steel Cross, 4" (10.2 cm) dia	01330903
Aluminized Steel Cross, 6" (15.2 cm) dia	01330904

Description	Part Number
Porcelain Coated Tee, 4" (10.2 cm) dia	0133022D
Aluminized Steel Tee, 4" (10.2 cm) dia	01330203
Aluminized Steel Tee, 6" dia (15.2 cm)	01330204

13.4 EP-100 Pump Models

See EP-100 Installation, Operation and Service Manual (P/N 127201NA) for assembly details.

13.5 EP-200 Pump Series

See EP-200 Installation, Operation and Service Manual (P/N 127200NA) for assembly details.

13.6 EP-300 Pump Series

See EP-300 Series Installation, Operation and Service Manual (P/N 127202NA) for assembly details.

13.7 Installation Precautions

⚠ WARNING



Severe Injury Hazard

Pumps are shipped partially assembled.

Do not operate a partially assembled pump.

Failure to follow these instructions can result in death or injury.

The pump scroll attaches to the pump frame (See Page 60, Figure 30) with either right- or left-hand discharge as the job requires. Please note that the motor must be wired differently depending on discharge direction. The discharge must be bottom horizontal. Any other arrangement will permit condensate to collect in the scroll.

FIGURE 29: Roof Venting of Pump

See sidewall venting illustration for guidelines on matching pump capacity to vent size. Length of pipe is equal to total of vertical and horizontal length.

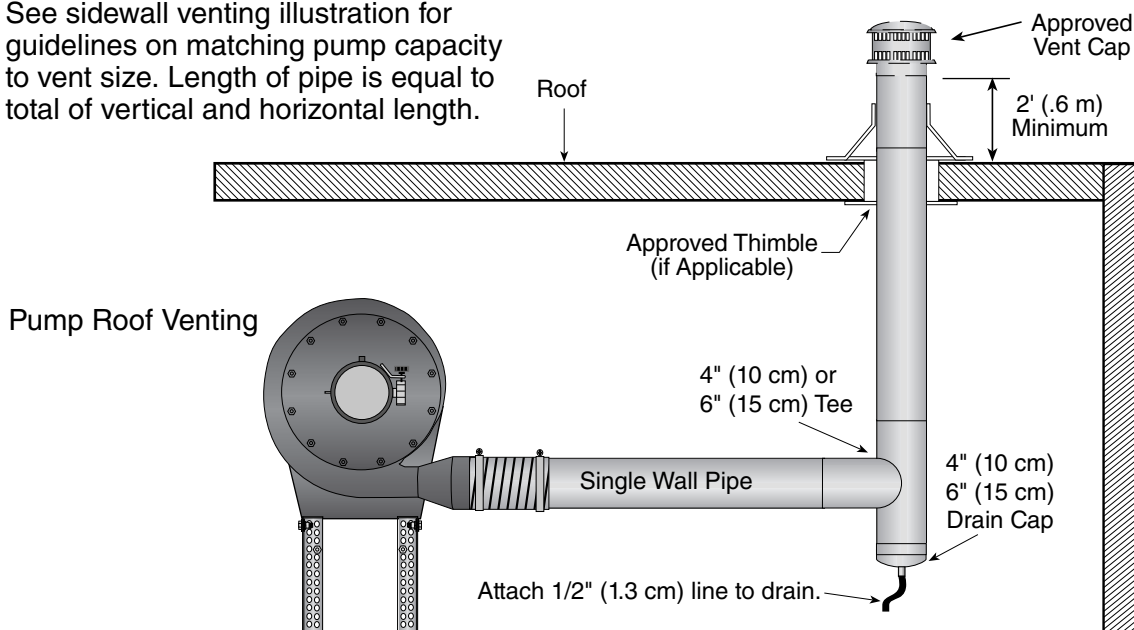

Description	Part Number
Drain Cap, 4" (10.2 cm) dia	02718851
Drain Cap, 6" (15.2 cm) dia	02718852
Tee, 4" (10.2 cm)	01330203

Description	Part Number
Tee, 6" (15.2 cm)	01330204
Vent Cap, 4" (10.2 cm)	90502300
Vent Cap, 6" (15.2 cm)	90502302

FIGURE 30: Side Wall Venting Configurations

EP-100 or EP-200 Pump Side Wall Venting

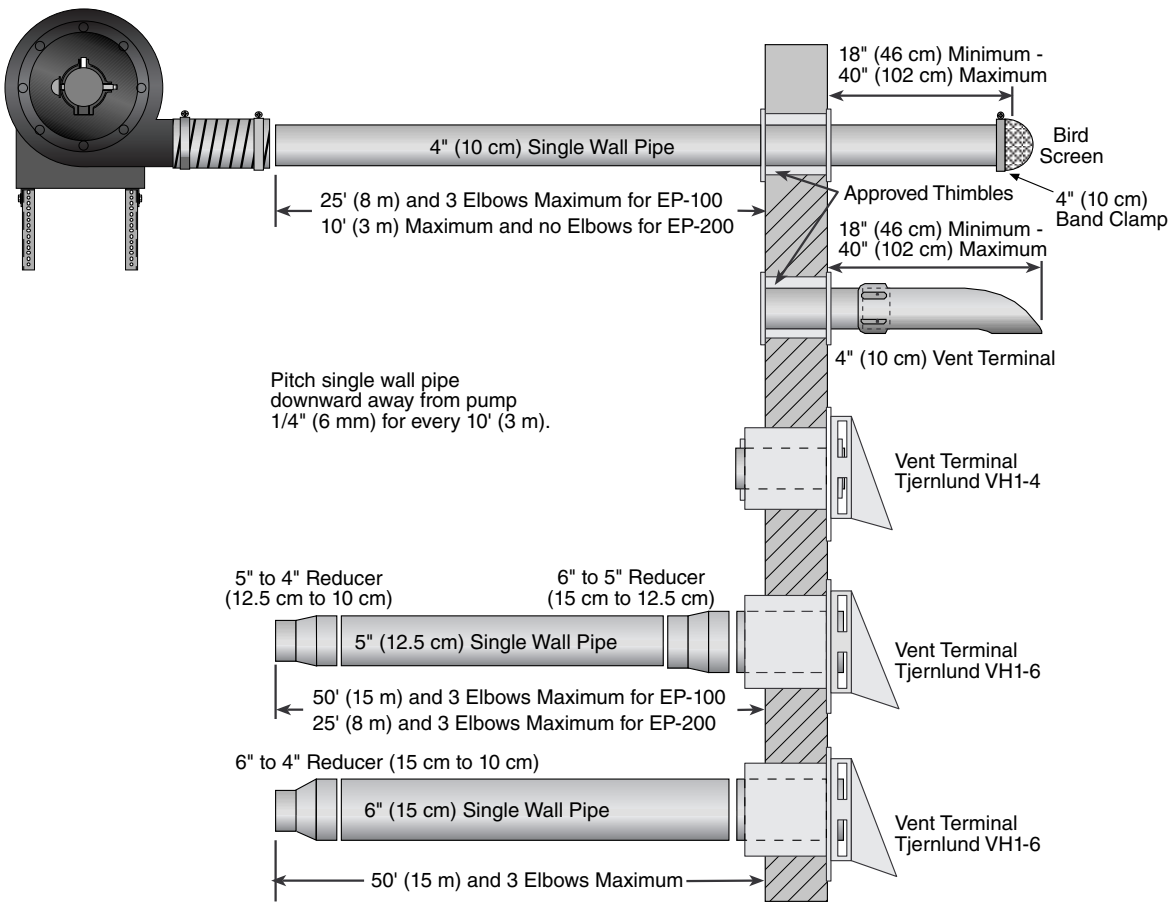

EP-300 Vacuum Pump Side Wall Venting

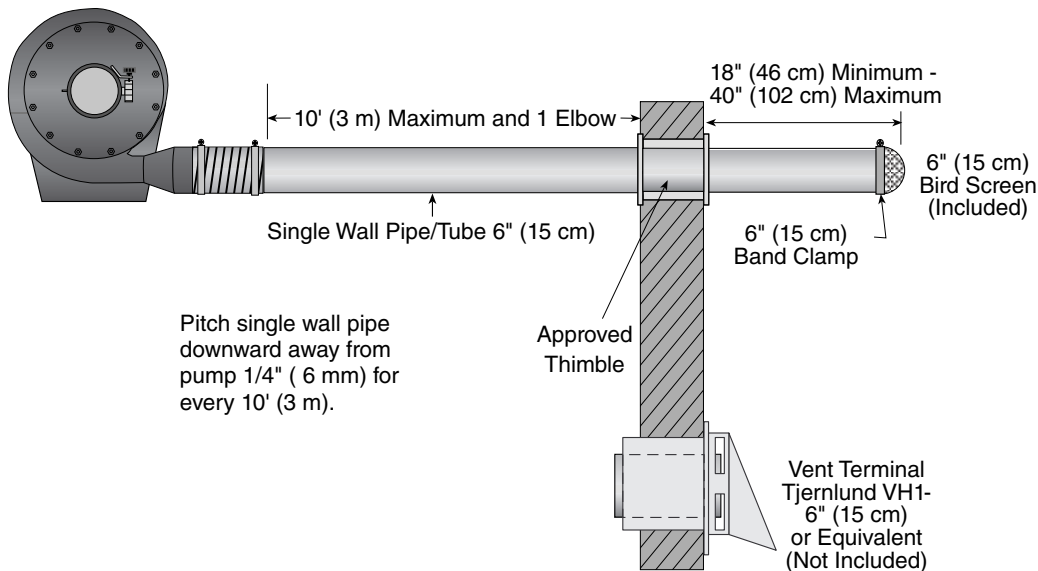

Description	Part Number
Bird Screen 4" (10 cm)	01365400
Bird Screen, 6" (15 cm)	01397400
Band Clamp, 4" (10 cm)	91901300
Band Clamp, 6" (15 cm)	91913703

Description	Part Number
Vent Terminal, 4" (10 cm)	02537801-IP
Vent Terminal, Tjernlund VH1-4	90502100
Vent Terminal, Tjernlund VH1-6	90502101

SECTION 14: OUTSIDE COMBUSTION AIR SUPPLY

IMPORTANT: If the building has a slight negative pressure or corrosive contaminants (such as halogenated hydrocarbons) are present in the air, an outside combustion air supply to the heater is required. Seal all combustion air pipe joints.

Use of optional outside combustion air is not recommended with unvented heaters.

The air supply duct may have to be insulated to prevent condensation on the outer surface. The outside air terminal must not be more than 1' (31 cm) above the vent terminal.

14.1 Length Requirements

Follow the constraints listed on *Page 54, Section 12.5.*

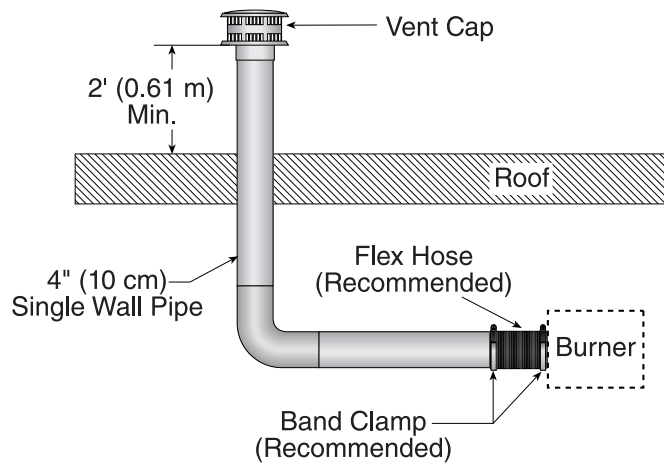
14.2 Vertical Non-Pressurized Outside Air Supply for Single Heater Installation

Description	Part Number
Vent Cap 4" (10 cm)	90502300

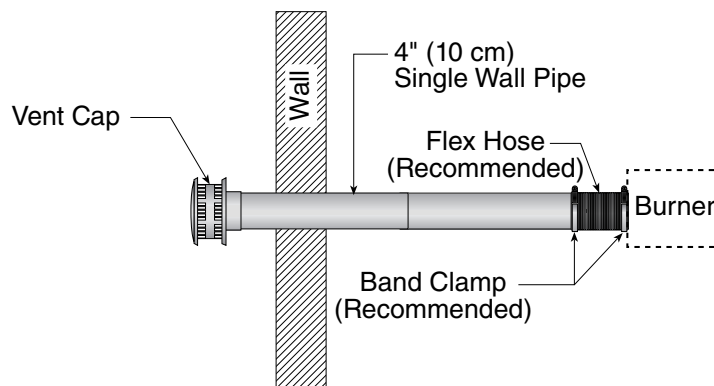
14.3 Horizontal Non-Pressurized Outside Air Supply for Single Heater Installation

Description	Part Number
Vent Cap 4" (10 cm)	90502300

14.4 Vertical Non-Pressurized Outside Air Supply for Double Heater Installation

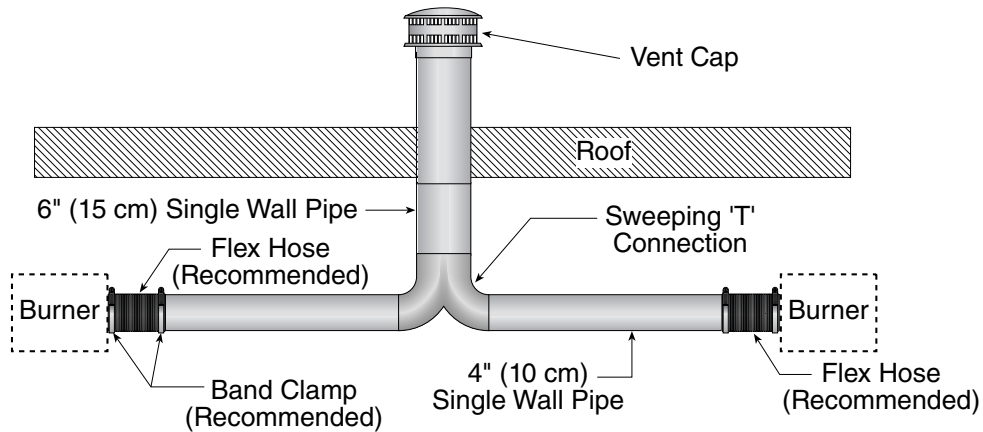

Description	Part Number
Vent Cap 6" (15 cm)	90502302

Requirements:

- Heaters must be controlled by a common thermostat.

14.5 Horizontal Non-Pressurized Outside Air Supply for Double Heater Installation

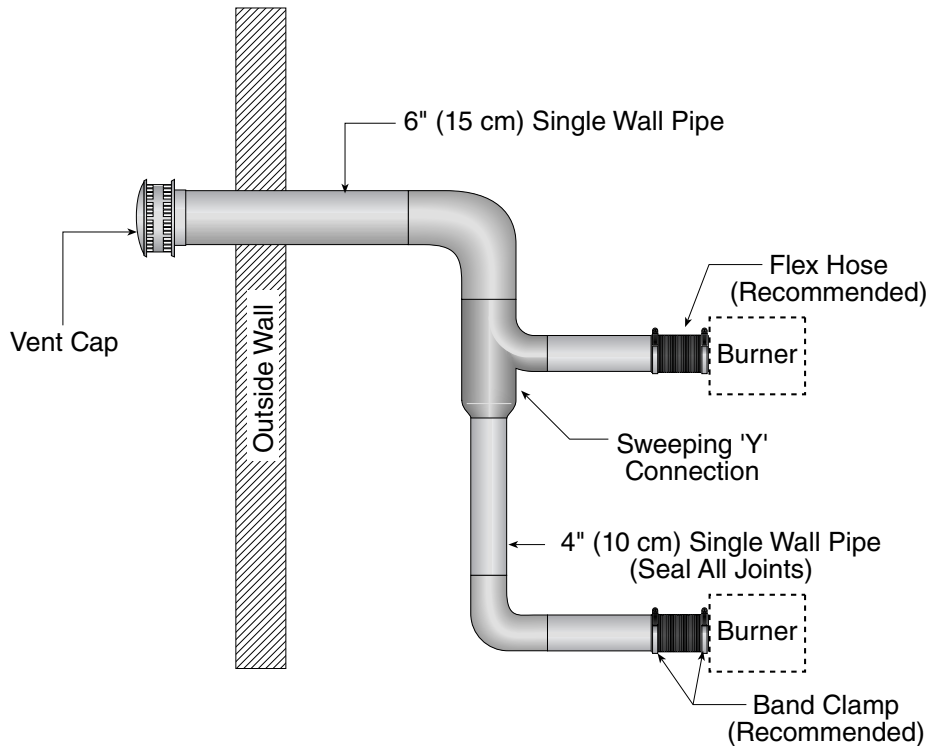

Description	Part Number
Vent Cap 6" (15 cm)	90502302

Requirements:

- Heaters must be controlled by a common thermostat.

14.6 Pressurized Outside Air Supply

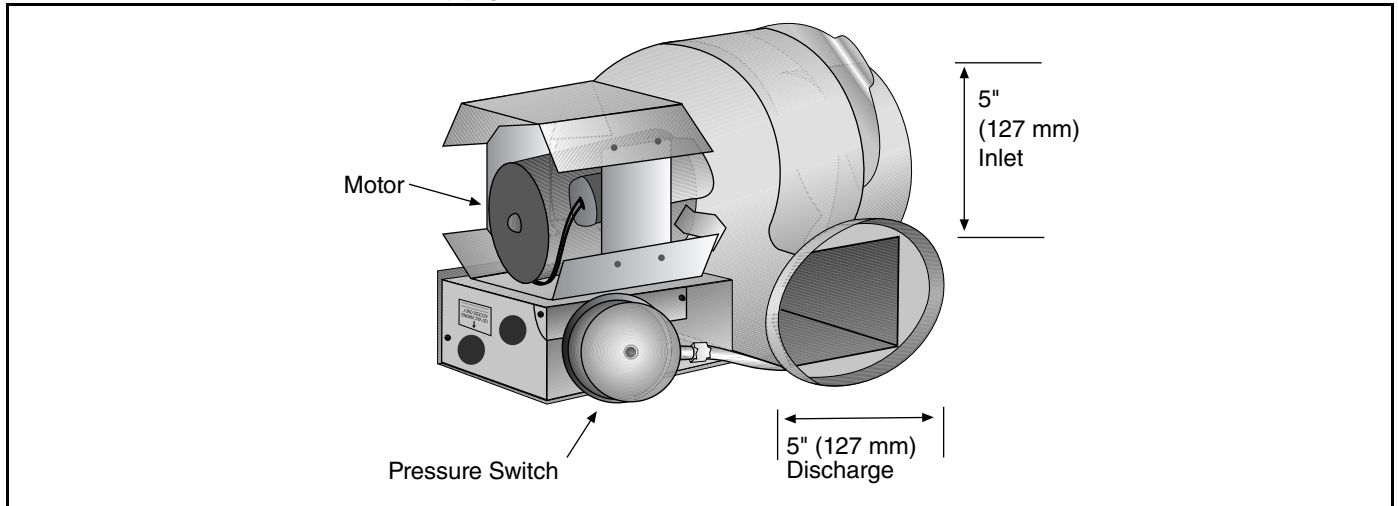

If used, the outside air supply blower (P/N 90707501K) should be wired in parallel with the pump, and in accordance with the National Electric Code® NFPA 70 - latest revision and local ordinances. The blower air pressure switch must be wired in series with the pressure switch on the pump.

All joints and seams in the air supply system must be airtight. See above instructions on attaching duct to the burner. Mount the blower according to the manufacturer's instructions. Additional mounting materials are provided by the contractor.

14.7 Outside Air Blower Internal Wiring

FIGURE 31: Outside Air Blower Internal Wiring Diagram

The outside air blower is shipped with the blower manufacturer's standard internal wiring. For use with ROBERTS GORDON® heaters, the outside air blower must be rewired with existing wires by the electrical contractor. See diagram.

NOTE: The internal 24 V relay provided will not be used and can be discarded.

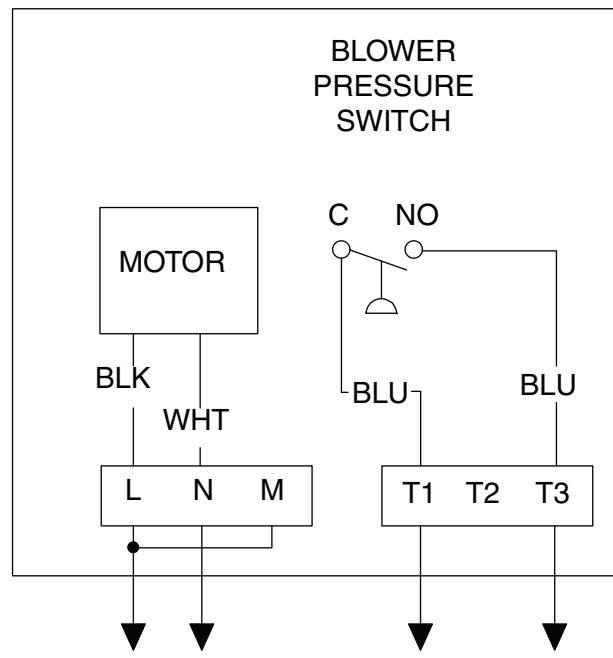

SECTION 15: WIRING

⚠ DANGER



Electrical Shock Hazard

Disconnect electric before service.

More than one disconnect switch may be required to disconnect electric from heater.

Heater must be properly grounded.

Failure to follow these instructions can result in death or electrical shock.

15.1 Internal Wiring

Heaters must be grounded in accordance with applicable codes:

United States: refer to National Electrical Code® NFPA 70 - latest revision.

Canada: Refer to Canadian Electrical Code, CSA C22.1 Part I - latest revision.

If any of the original internal wiring must be replaced, it must be replaced with wiring materials having a temperature rating of at least 105°C and 600 volts.

15.2 Internal Wiring

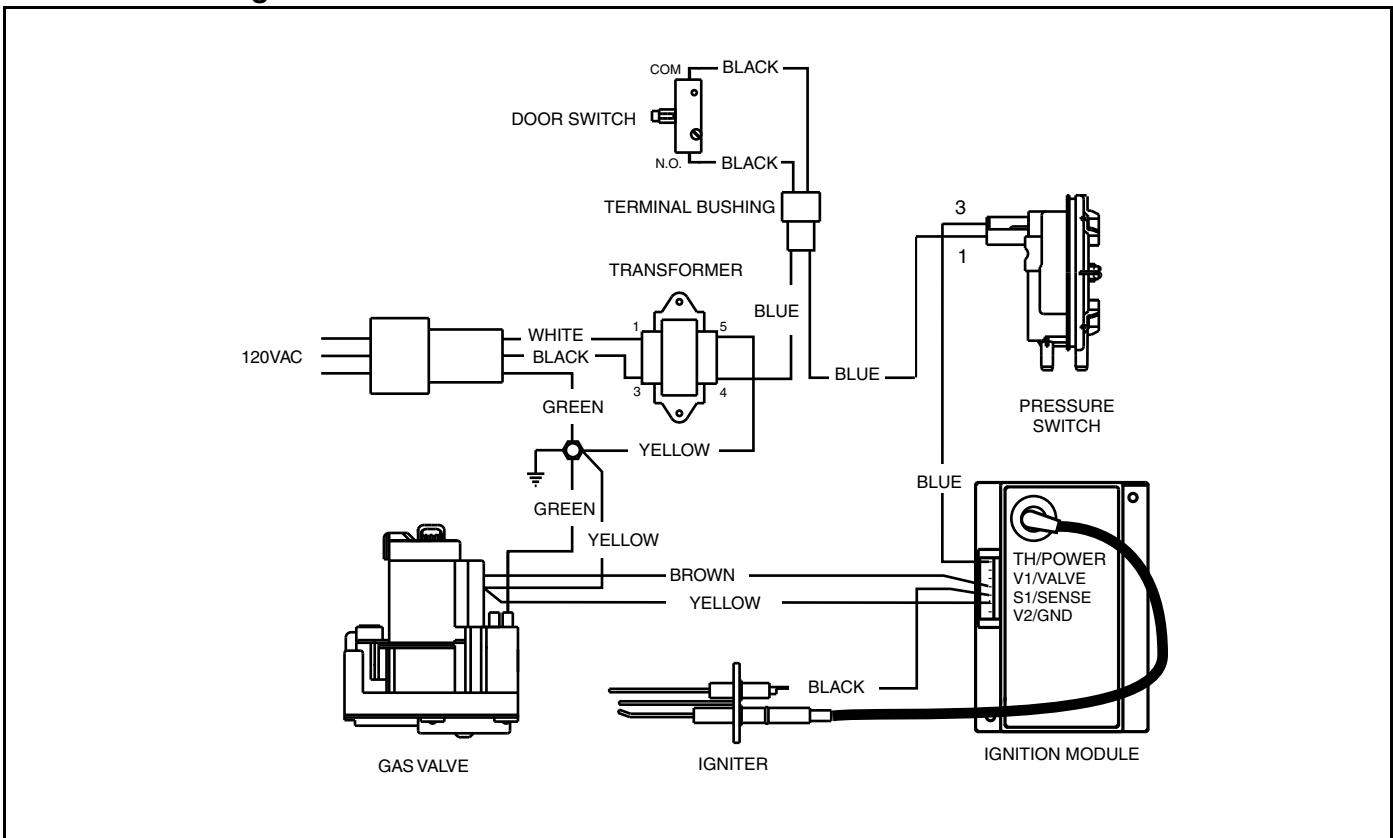

15.3 Ladder Diagram

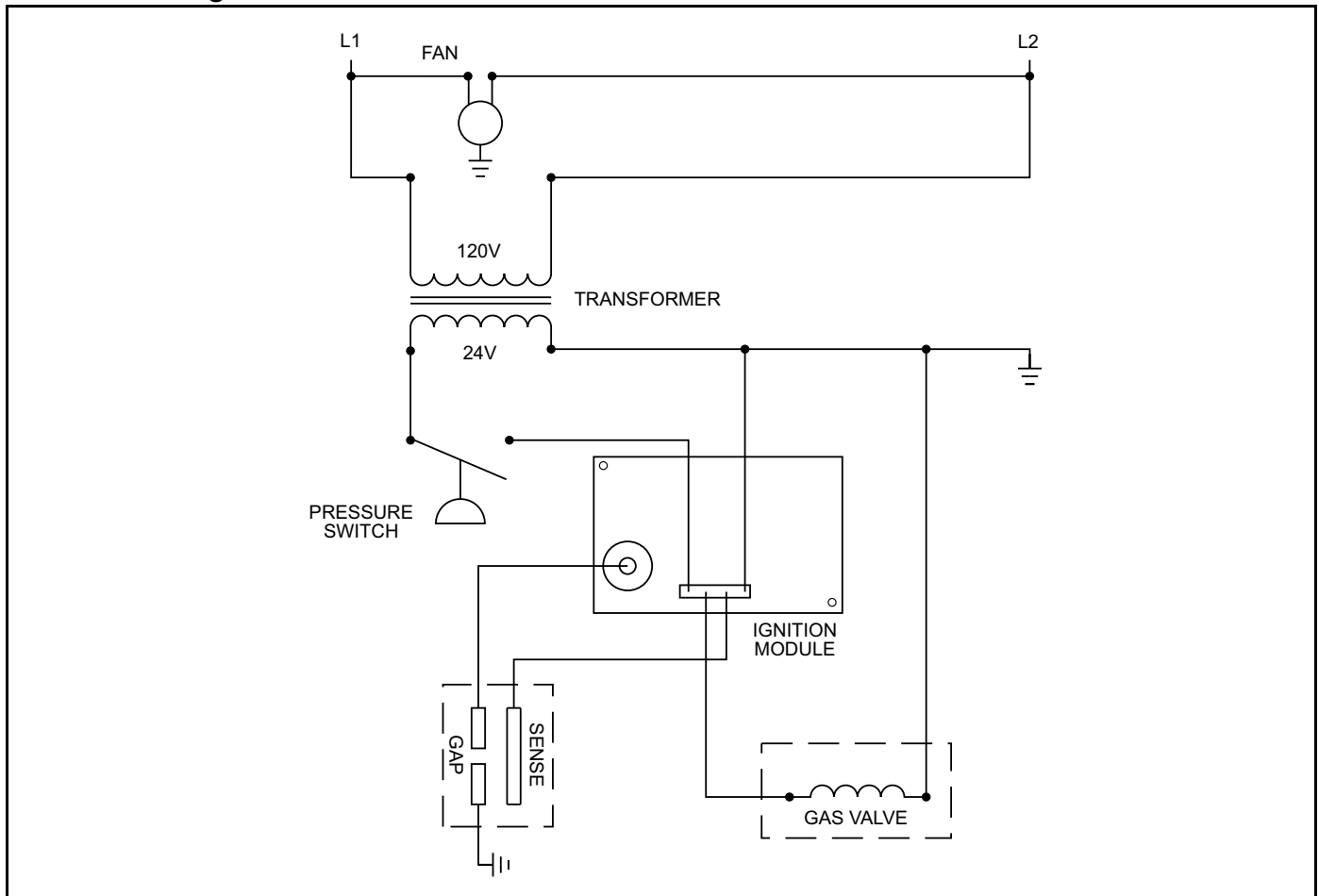

15.4 External Wiring (Unitary Heaters Only)

Heaters can be controlled using several methods. Normally thermostats are used to control the heaters, but they can also be controlled by an energy management system. *Page 66, Section 15.5* illustrates the connection for heaters controlled by a line voltage thermostat. For single or multiple heaters on one low voltage thermostat, see *Page 66, Section 15.6*.

15.5 Line Voltage Thermostat Wiring (Unitary Heaters Only)

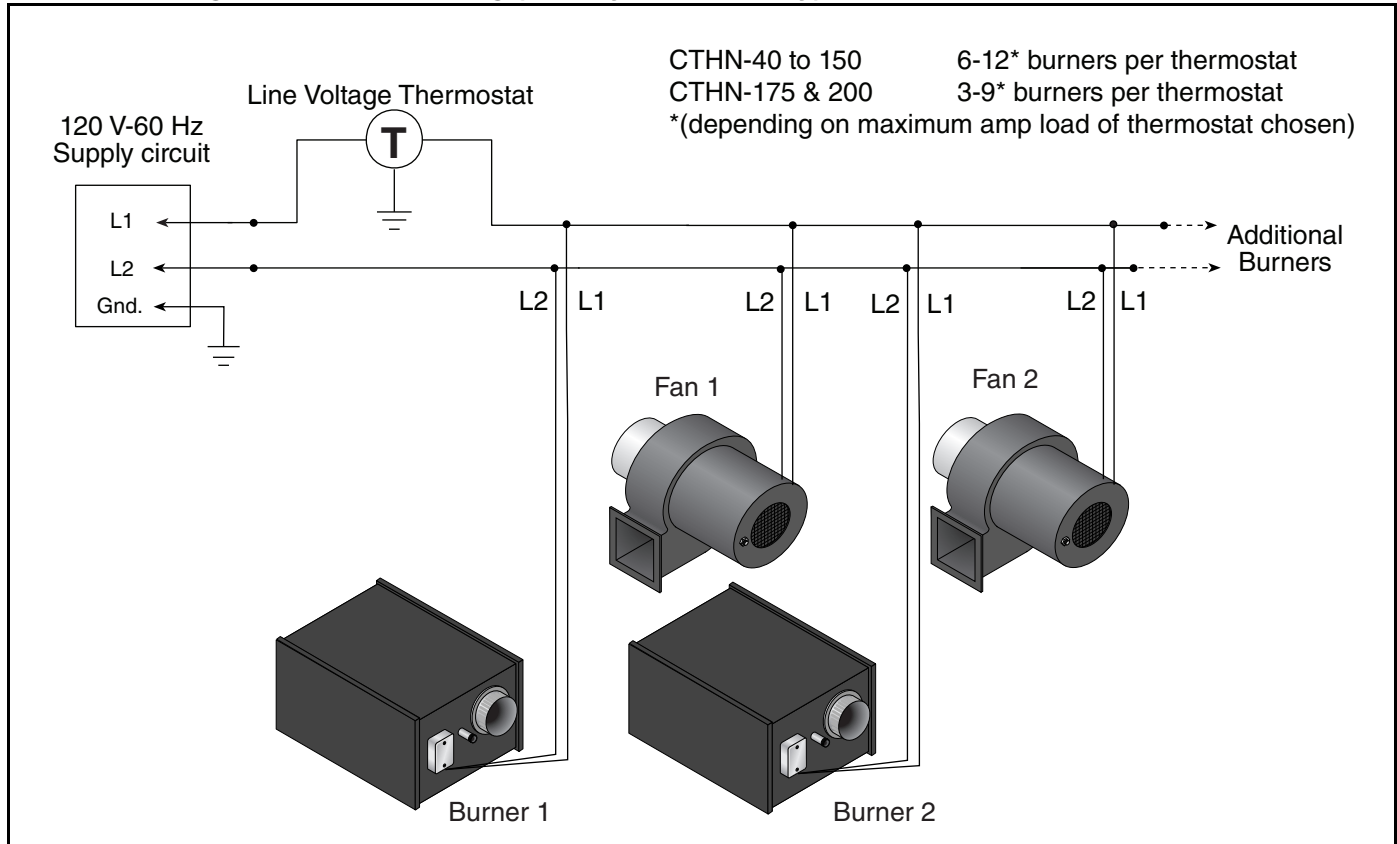

15.6 Low Voltage Thermostat Wiring (Unitary Heaters Only)

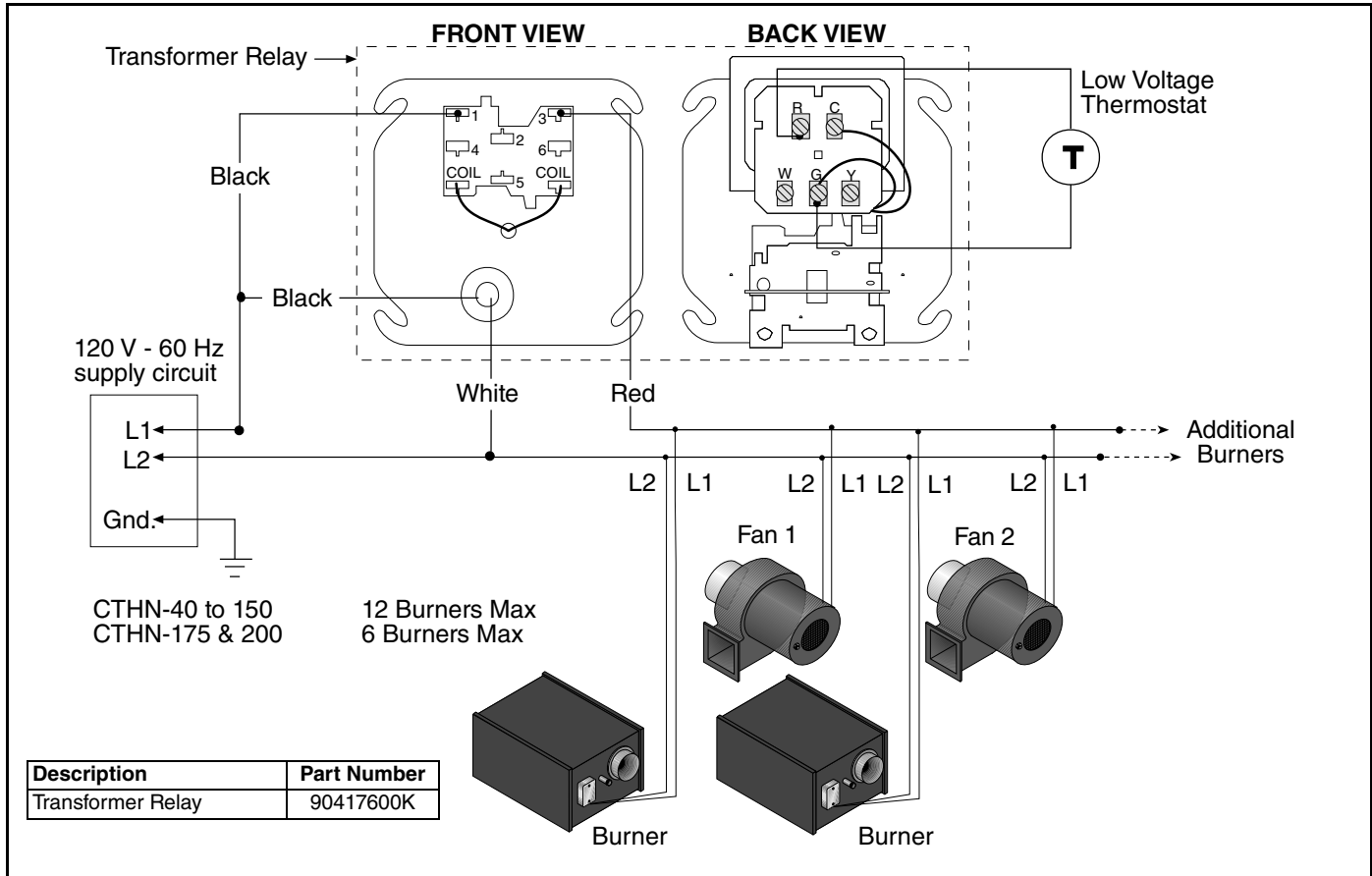

15.7 System Control Methods and External Multiburner Wiring

There are several methods of controlling CTHN-Series systems. The options are as follows:

15.7.1 SPST Transformer Relay (P/N 90417600K)

The transformer relay wiring diagram is shown *on Page 68, Figure 32*. The transformer relay can be used to control an EP-100 or EP-201 pump CTHN system. The single pole relay can only be used to control one zone of burners.

The electrical circuit is a 120V AC (20 A) supply.

The transformer 24V AC output for the thermostat is rated at 40VA. Thermostats used with the transformer must not exceed this power requirement.

A transformer relay operated system will not give any post purge pump operation to completely exhaust products of combustion from the system or provide indication of operating conditions.

15.7.2 SPDT Transformer Relay (P/N 90436300)

The transformer relay wiring diagram is shown *on Page 69, Figure 33*. The transformer relay can be used to control an EP-100 or EP-201 pump CTHN system. The double pole relay can only be used to control two zones of burners.

The electrical circuit is a 120V AC (20 A) supply.

The transformer 24V AC output for the thermostat is rated at 40VA. Thermostats used with the transformer must not exceed this power requirement.

A transformer relay operated system will not give any post purge pump operation to completely exhaust products of combustion from the system or provide indication of operating conditions.

FIGURE 32: One Zone Operation without Control Panel (Multiburner)

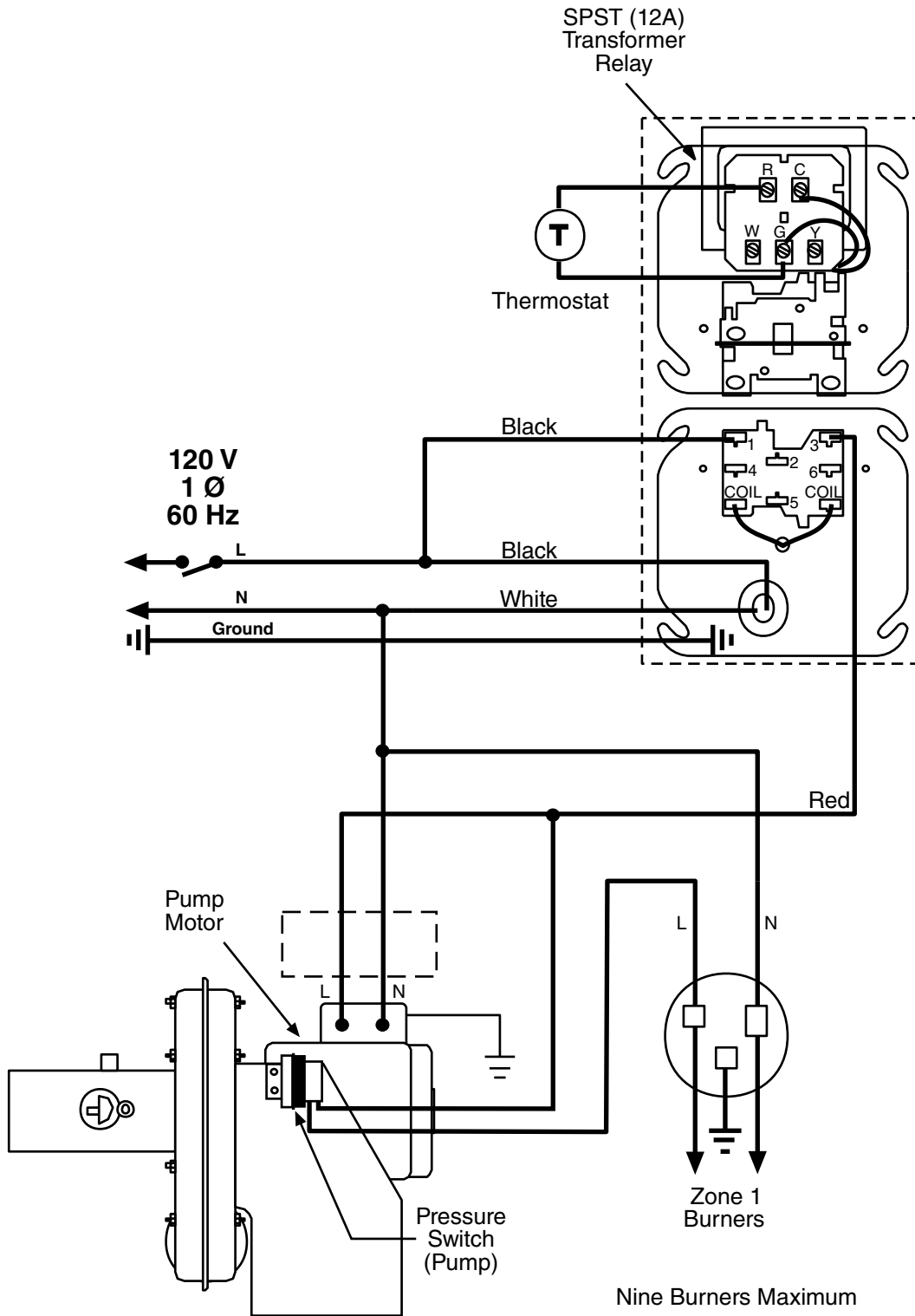

Description	Part Number
SPST Transformer Relay	90417600K

FIGURE 33: Two Zone Operation without Control Panel (Multiburner)

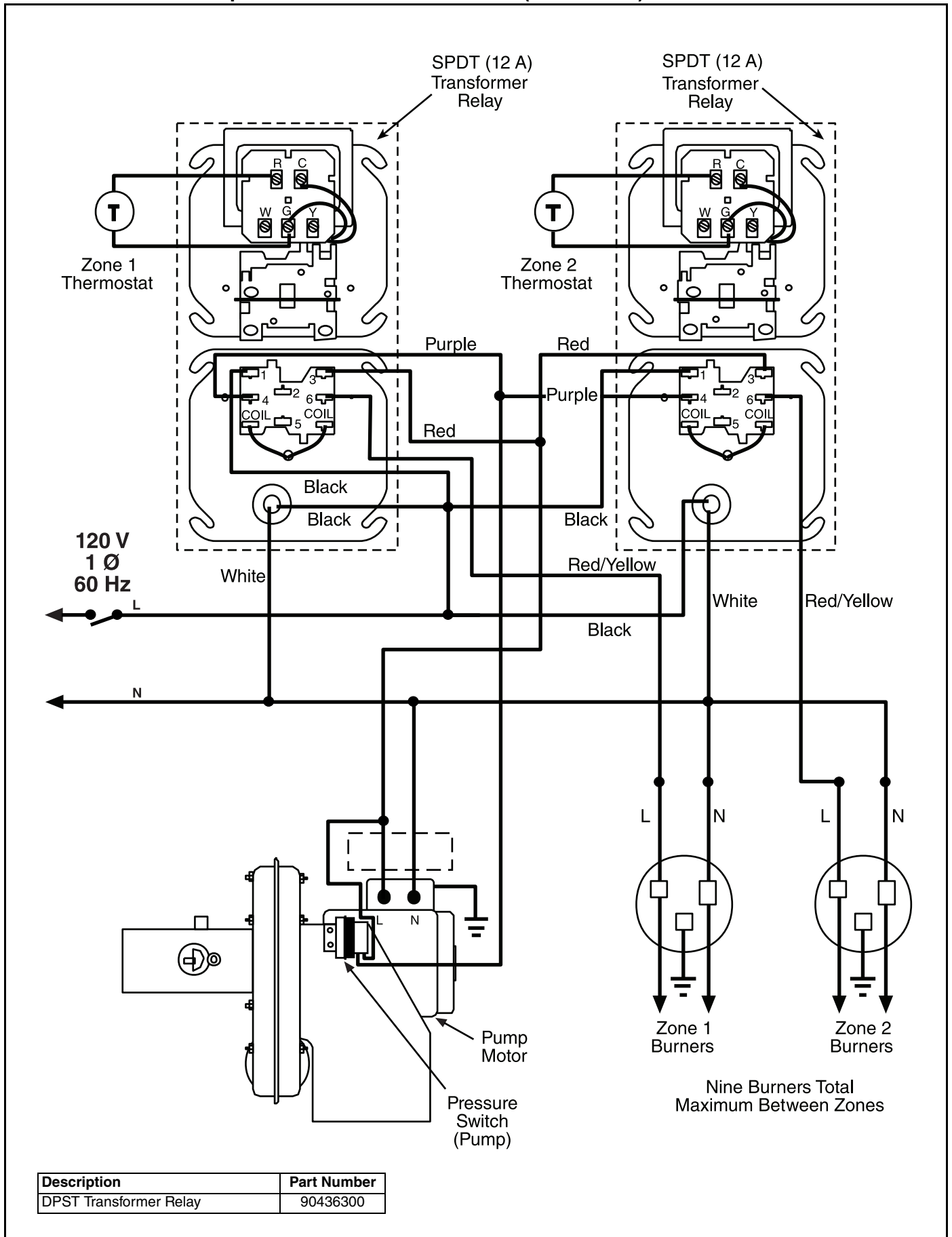

SECTION 16: GAS PIPING

⚠ WARNING

Fire Hazard
<p>Tighten gas hose fittings to connect gas supply according to Figure 34.</p> <p>Gas hose can crack when twisted.</p> <p>Gas hose moves during normal operation.</p> <p>Use only 36" (91 cm) long connector of 1/2" or 3/4" nominal ID.</p> <p>Connector supplied with heater for U.S. models (not with Canadian models).</p> <p>Failure to follow these instructions can result in death, injury or property damage.</p>

Install the gas hose as shown on *Page 71, Figure 34*. The gas hose accommodates expansion of the heating system and allows for easy installation and service of the burner. Before connecting the burners to the supply system, verify that all high pressure testing of the gas piping has been completed.

There is an expansion of the tube with each firing cycle. This will cause the burner to move with respect to the gas line. This can cause a gas leak resulting in an unsafe condition if the gas connection is not made strictly in accordance with *Figure 34 on Page 71*.

Meter and service must be large enough to handle all the burners being installed plus any other connected load. The gas line which feeds the system must be large enough to supply the required gas with a maximum pressure drop of 1/2" wc. When gas piping is not included in the layout drawing, the local gas supplier will usually help in planning the gas piping.

Gas lines must meet applicable codes:

United States: The Flexible Stainless Steel Gas Hose (US models) supplied with the heater is certified per the Standard for Connectors for Gas Appliances, ANSI Z21.24/CSA 6.10 - latest revision.

Canada: The Rubber Type 1 Gas Hose (Canadian models) optional with the heater is certified as being in compliance with the Standard for Elastomeric Composite Hose and Hose Couplings for Conducting Propane and Natural Gas, CAN/CGA 8.1 - Latest revision.

- **Check the pipe and tubing ends for leaks before placing heating equipment into service. When checking for gas leaks, use a soap and water solution; never use an open flame.**

⚠ WARNING

Explosion Hazard
<p>Leak test all components of gas piping before operation.</p> <p>Gas can leak if piping is not installed properly.</p> <p>Do not high pressure test gas piping with heater connected.</p> <p>Failure to follow these instructions can result in death, injury or property damage.</p>

FIGURE 34: Gas Connection with Flexible Gas Hose

CORRECT POSITIONS

⚠ CAUTION

Product Damage Hazard

Hold gas nipple securely with pipe wrench when attaching gas hose.

Failure to follow these instructions can result in product damage.

Shut-Off Valve (included with gas hose) must be parallel to burner gas inlet. The 3" (8 cm) displacement shown is for the cold condition. This displacement may reduce when the system is fired.

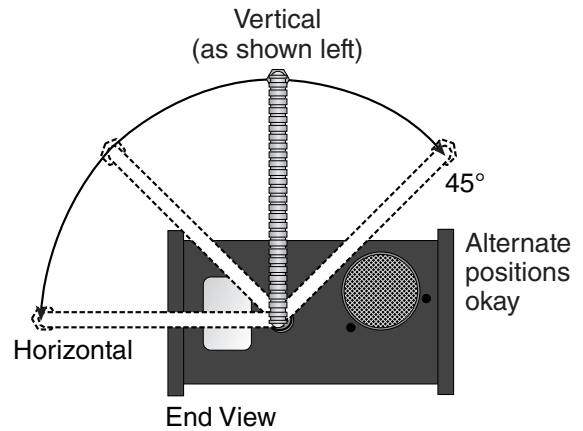
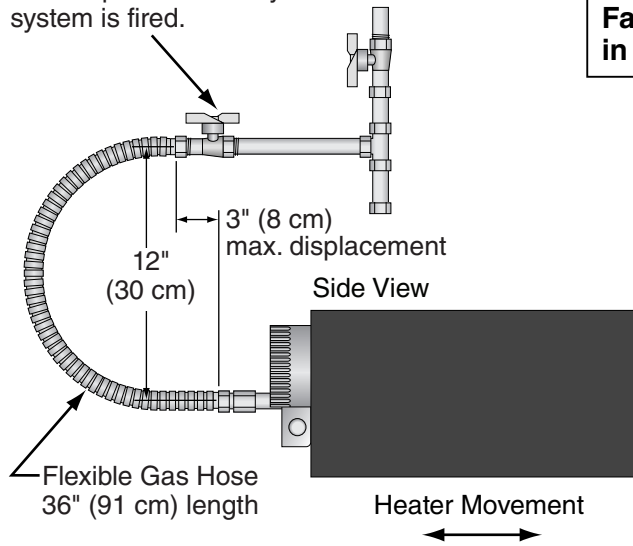



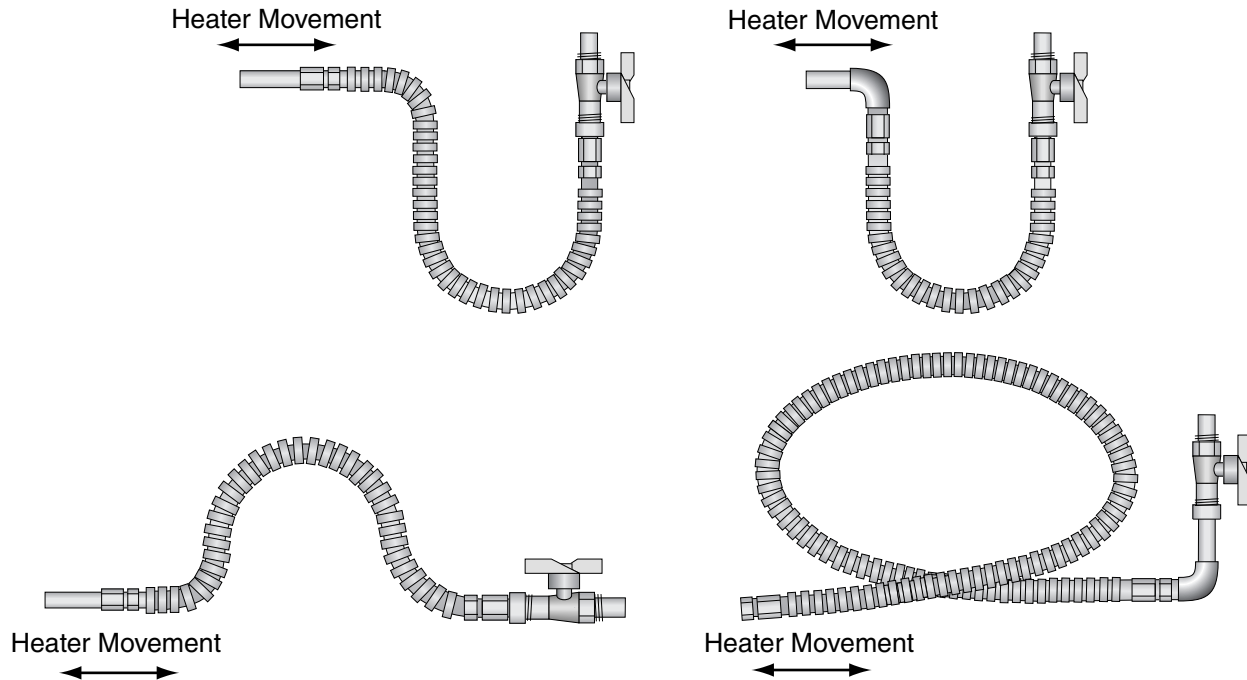

INCORRECT POSITIONS (WRONG INSTALLATION)



Description	Part Number
1/2" Flexible Stainless Steel Gas Hose (US Models)	91412200
3/4" Flexible Stainless Steel Gas Hose (US Models)	91412204
1/2" Rubber (Type 1) Gas Hose (Canadian Models)	91412206
3/4" Rubber (Type 1) Gas Hose (Canadian Models)	91412207

SECTION 17: OPERATION AND MAINTENANCE

⚠ DANGER		⚠ WARNING	
			
<p>Electrical Shock Hazard</p> <p>Disconnect electric before service.</p> <p>More than one disconnect switch may be required to disconnect electric from heater.</p> <p>Heater must be connected to a properly grounded electrical source.</p>	<p>Explosion Hazard</p> <p>Turn off gas supply to heater before service.</p>	<p>Burn Hazard</p> <p>Allow heater to cool before service.</p> <p>Tubing may still be hot after operation.</p>	<p>Cut/Pinch Hazard</p> <p>Wear protective gear during installation, operation and service.</p> <p>Edges are sharp.</p>
<p>Failure to follow these instructions can result in death, electric shock, injury or property damage.</p>			

The CTHN-Series heater is equipped with a direct spark ignition system.

17.1 Checking the Gas Line

1. Open main valve and verify that no gas is flowing through the gas meter.
2. Purge the line if this was not done following pressure testing with air.
3. Verify that the gas pressure is not above 14" wc (1/2 PSIG)
4. Close main gas valve.

17.2 Unitary Heater Sequence of Operation

1. Turn the thermostat up. When the thermostat calls for heat, the blower motor will energize.
2. When the fan motor achieves normal running RPM, the pressure switch within the burner closes and energizes the ignition module.
3. After a 45 second pre-purge, the ignition module then opens the gas valve and energizes the electrode. When the flame is established, the sparking sequence ceases.
4. If the flame is not established during the ignition sequence, the ignition module closes the gas valve and purge begins. The ignition module will

try 2 additional times for ignition (with purge between). If ignition is not established, the module will lock-out.

NOTE: After 1 hour, the module will reset automatically and return to steps 3 and 4.

5. If a flame is detected, the gas valve remains open. When the call for heat is satisfied, the thermostat turns off the burner and fan power supply.
6. If the flame extinguishes during operation, the ignition module will attempt to re-establish the flame as described in the preceding step. If ignition is not re-established, the module will lock-out.
7. After lock-out, the control must be reset by turning down the thermostat for five seconds, then raising it again to the desired temperature, or by disconnecting and re-connecting power to the control.

17.2.1 To Shut Off Heater - Unitary

- Set thermostat to lowest setting.
- Turn OFF electric power to heater.
- Turn OFF manual gas valve in the heater supply line.

17.2.2 To Start Heater - Unitary

Turn gas valve and electric power OFF and wait five minutes for unburned gases to vent from heater.

Turn ON main gas valve.

Turn ON electric power.

Set thermostat to desired temperature. Burner should light automatically.

Once the heater is operating, keep away from heater. Do not touch any part of the heater because it is very hot.

17.3 Multiburner System Operation

17.3.1 Checking the Electrical System

1. Set all thermostats below room temperature.
2. Turn on power supply to the system controls.
3. Check to see that no part of the system (i.e. burners, pump, outside air supply blower) is powered.
4. Individually check each zone by energizing the thermostats separately. Each zone thermostat should start the pump immediately. When the pump reaches the nominal running RPM, the pressure switch closes and activates the ignition module. A pre-purge period will precede burner ignition trial.
5. If more than one system is installed, be sure that no part of one system is affected by the controls of a different system.
6. Make a preliminary vacuum check at burners in branches which have an adjustable damper coupling. See Page 74, Figure 35 for vacuum measuring instructions. This check is to ensure that all dampers are open before the system is fired. The vacuum measured in the burner control housing should be more than .75" wc.

17.3.2 Starting the System - Multiburner

Note: During the initial firing, the protective oil on the tube may smoke for 30 to 60 minutes and adequate ventilation should be provided.

1. Start with all thermostats below room temperature.
2. Open main gas valve.
3. Turn up thermostats one at a time, waiting to see that all burners in a zone start. When the

burner ignites, a blue flame will be observed through the viewer window.

4. If any abnormal operation occurs, see Page 78, Section 18.1.

17.3.3 Sequence of Operation - Multiburner

1. Thermostat, on a call for heat, signals the control panel or relay contacts to energize the pump motor. The pump (and outside air supply blower, if used) are activated.
2. When the pump motor achieves normal running RPM, the pressure switch at the pump inlet closes.
3. After a minimum 45-60 second pre-purge delay (system control only), the zone relay corresponding to the thermostat calling for heat is energized (system control only), and line voltage is directed to the burners in the zone.
4. When sufficient vacuum differential (see Page 74, Section 17.3.6) is available at the burner and the control system is supplying line voltage to the burner, the pressure switch within the burner closes and energizes the ignition module.
5. After a 45 second pre-purge, the ignition module opens the gas valve and energizes the electrode. When the flame is established, the sparking sequence ends.
6. If the flame is not established during the ignition sequence, the ignition module closes the gas valve and purge begins. The ignition module will try 2 additional times for ignition (with purge between). If ignition is not established, the module will lock-out.
NOTE: After 1 hour, the module will reset automatically and return to steps 5 and 6.
7. If a flame is detected, the gas valve remains open. When the call for heat is satisfied, the system control or relay de-energizes the burner and pump power supply. When using the system control, the pump turns off after a post-purge period.
8. If the flame extinguishes during operation, the ignition module will attempt to re-establish the flame. If ignition is not re-established, the module will lock-out.

9. After lock-out, the control must be reset by turning down the thermostat for five seconds, then raising it again to the desired temperature, or by disconnecting and re-connecting power to the control.

17.3.4 To Shut Off Heater - Multiburner

See Page 72, Section 17.2.1.

17.3.5 To Start Heater - Multiburner

See Page 73, Section 17.2.2

17.3.6 Setting the Vacuum - Multiburner

1. Set thermostats above room temperature. See that all burners are operating properly.
2. Allow at least one-half hour operation for temperature to normalize before checking system vacuum balance. Vacuum differential can be measured by connecting a manometer across the “tee” tappings inside the control housing (after measurement, the caps must be

installed on the “tees” to prevent leakage). See *Figure 35* for manometer connection to burner control housing.

3. Approximately 1.0" of vacuum differential is required at the burner when the system is cold. Normal operating (hot) differential of the burners should be adjusted to .75" wc.

Vacuum adjustments are made by means of the pump inlet damper and the adjustable damper coupling(s). Check the vacuum differential at all burners, then adjust the damper coupling to obtain equal vacuum differential readings. Adjust the pump inlet damper until vacuum differentials at the burners are as given above. With systems designed to capacity, it may not be possible to obtain vacuum differential readings at slightly above 1" wc (when cold). If so, adjust damper couplings to maximum but approximately equal vacuum readings. Be sure to lock all dampers securely after adjustment.

4. Reset thermostats to desired room temperature.
5. If heat is not required, turn off main switch and close main gas valve.

FIGURE 35: Vacuum Differential Reading

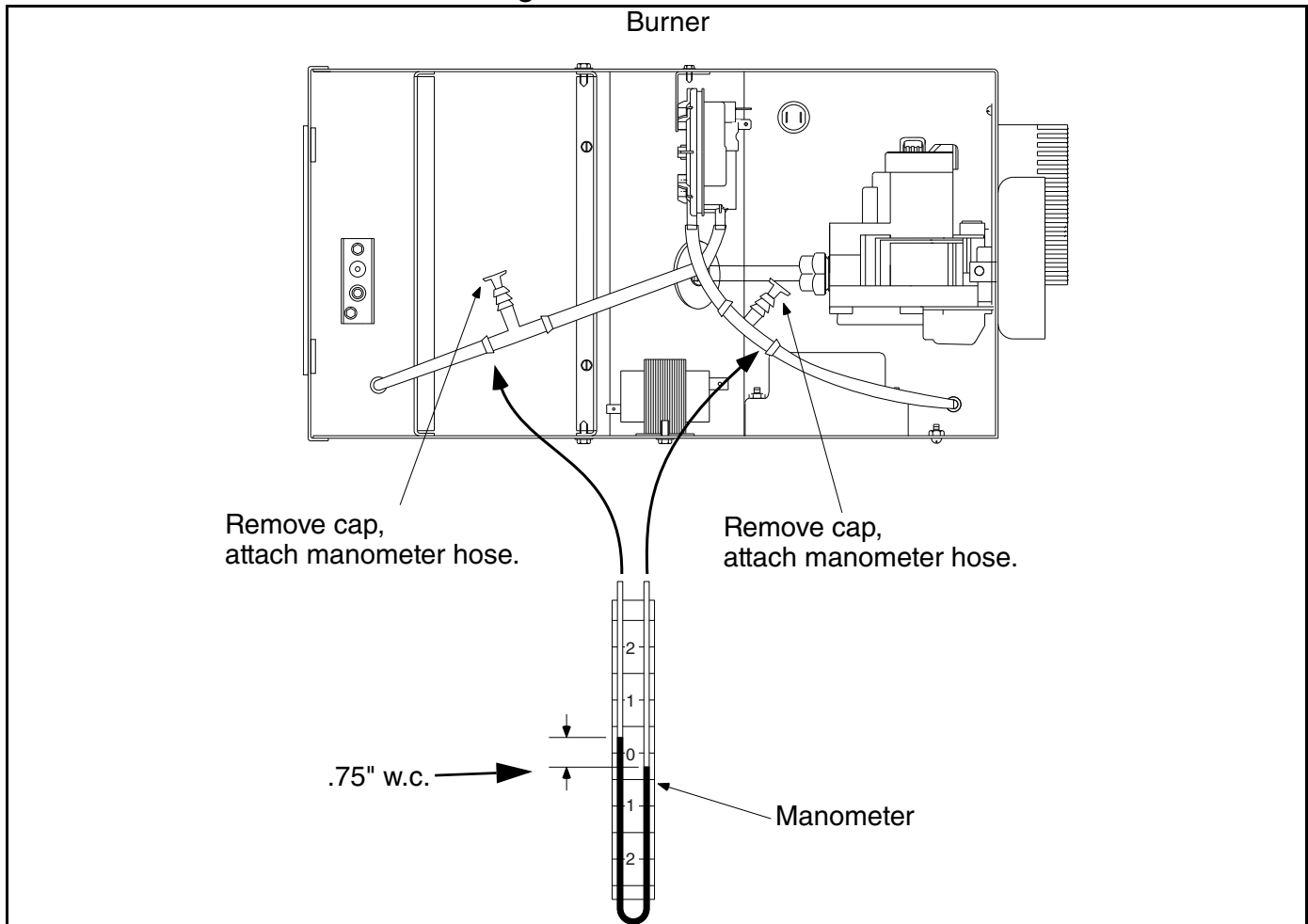

17.4 Maintenance

17.4.1 Pre-Season Maintenance and Annual Inspection

To ensure your safety and years of trouble-free operation of the heating system, service and annual inspections must be done by a contractor qualified in the installation and service of gas-fired heating equipment.

Turn off gas and electric supplies before performing service or maintenance. Allow heater to cool before servicing.

Before every heating season, a contractor qualified in the installation and service of gas-fired heating equipment must perform a thorough safety inspection of the heater.

For best performance, the gas, electrical, thermostat connections, tubing, venting, suspensions and overall heater condition should be thoroughly inspected.

first things that should be inspected.

Please see *Page 75, Section 17.5* for suggested items to inspect.

17.5 Maintenance Checklist

Installation Code and Annual Inspections:

All installation and service of ROBERTS GORDON® equipment must be performed by a contractor qualified in the installation and service of equipment sold and supplied by Roberts-Gordon and conform to all requirements set forth in the ROBERTS GORDON® manuals and all applicable governmental authorities pertaining to the installation, service, operation and labeling of the equipment.

To help facilitate optimum performance and safety, Roberts-Gordon recommends that a qualified contractor conduct, at a minimum, annual inspections of your ROBERTS GORDON® equipment and perform service where necessary, using only replacement parts sold and supplied by Roberts-Gordon.

NOTE: Gas flow and burner ignition are among the

The Vicinity of the Heater	<p>Do not store or use flammable objects, liquids or vapors near the heater. Immediately remove these items if they are present.</p> <p><i>See Page 5, Section 3.</i></p>
Vehicles and Other Objects	<p>Maintain the clearances to combustibles.</p> <p>Do not hang anything from, or place anything on, the heater.</p> <p>Make sure nothing is lodged underneath the reflector, in between the tubes or in the decorative or protective grilles (included with select models).</p> <p>Immediately remove objects in violation of the clearances to combustibles.</p> <p><i>See Page 5, Section 3.</i></p>
Reflector	<p>Support reflector with reflector hanger and support strap.</p> <p>Reflector must not touch tube.</p> <p>Make sure there is no dirt, sagging, cracking or distortion.</p> <p>Do not operate if there is sagging, cracking or distortion.</p> <p>Make sure reflectors are correctly overlapped. <i>See Page 27, Section 8.9.1.</i></p> <p>Clean outside surface with a damp cloth.</p>
Vent Pipe	<p>Venting must be intact. Using a flashlight, look for obstructions, cracks on the pipe, gaps in the sealed areas or corrosion.</p> <p>The area must be free of dirt and dust.</p> <p>Remove any carbon deposits or scale using a wire brush.</p> <p>Inspect pump and flue pipe for soot or dirt or any obstruction to the outdoors. After cleaning as necessary, reattach the flue pipe to the heater. Inspect acoustical boots for cracks and leaks. Replace as necessary.</p> <p><i>See Page 53, Section 11.</i></p>

Outside Air Inlet	<p>Inlet must be intact. Look for obstructions, cracks on the pipe, gaps in the sealed areas or corrosion.</p> <p>The area must be free of dirt and dust. Clean and reinstall as required.</p>
Tubes	<p>Make sure there are no cracks.</p> <p>Make sure tubes are connected and suspended securely.</p> <p>See <i>Page 13, Figure 14</i>.</p> <p>Make sure there is no dirt, sagging, bending or distortion.</p> <p>Clean or replace as required.</p>
Gas Line	<p>Check for gas leaks. See <i>Page 70, Section 16</i>.</p>
Burner Observation Window	<p>Make sure it is clean and free of cracks or holes.</p> <p>Clean or replace as required.</p>
Blower Scroll, Wheel and Motor	<p>Compressed air or a vacuum cleaner may be used to clean dust and dirt.</p>
Burner Cup and Orifice	<p>Make sure it is clear of obstructions (even spider webs will cause problems).</p> <p>Carefully remove any dust and debris from the burner.</p>
Electrode	<p>Replace if there are cracked ceramics, excessive carbon residue, or erosion of the electrode.</p> <p>The electrode gap should be 1/8" (3.2 mm).</p>
Thermostat	<p>There should be no exposed wire or damage to the thermostat.</p> <p>See <i>Page 66, Section 15.5</i>.</p>
Suspension Points	<p>Make sure the heater is hanging securely. Look for signs of wear on the chain or ceiling.</p> <p>See <i>Page 13, Figure 14</i>.</p>
Decorative and Protective Grille (optional)	<p>The grille must be securely attached.</p> <p>Check that side reflector extensions are installed correctly and secured in place if necessary. (Decorative grille only.)</p> <p>See <i>Page 50, Section 10.4 through Page 52, Section 10.5</i></p> <p>Make sure shield is installed correctly and secured in place if necessary. (Decorative grille only.) See <i>Page 50, Section 10.4.2</i>.</p>
Lower Clearance Shield (optional)	<p>The lower shield must be securely attached.</p> <p>See <i>Page 49, Section 10.3</i> .</p> <p>Make sure shield is installed correctly and secured in place if necessary.</p> <p>See <i>Page 49, Section 10.3.1</i>.</p>
Wall Tag	<p>If wall tag is present, make sure it is legible and accurate. Please contact Roberts-Gordon LLC or your ROBERTS GORDON® independent distributor, if you need a wall tag. See <i>Page 4, Section 2.1</i>.</p>
Safety Labels	<p>Product safety signs or labels should be replaced by the product user when they are no longer legible. Please contact Roberts-Gordon LLC or your ROBERTS GORDON® independent distributor to obtain replacement signs or labels. See <i>Page 2, Figure 1 through Page 3, Figure 2</i>.</p>

SECTION 18: TROUBLESHOOTING

⚠ DANGER**Electrical Shock Hazard**

Disconnect electric before service.

Heater must be properly grounded.

Failure to follow these instructions can result in death or electrical shock.

⚠ WARNING**Fire Hazard**

Keep all flammable objects, liquids and vapors the minimum required clearances to combustibles away from heater.

Some objects will catch fire or explode when placed close to heater.

**Explosion Hazard**

Turn off gas supply to heater before service.

**Burn Hazard**

Allow heater to cool before service.

Tubing may still be hot after operation.

**Cut/Pinch Hazard**

Wear protective gear during installation, operation and service.

Edges are sharp.

Failure to follow these instructions can result in death, injury or property damage.

18.1 Troubleshooting Flow Chart - Unitary

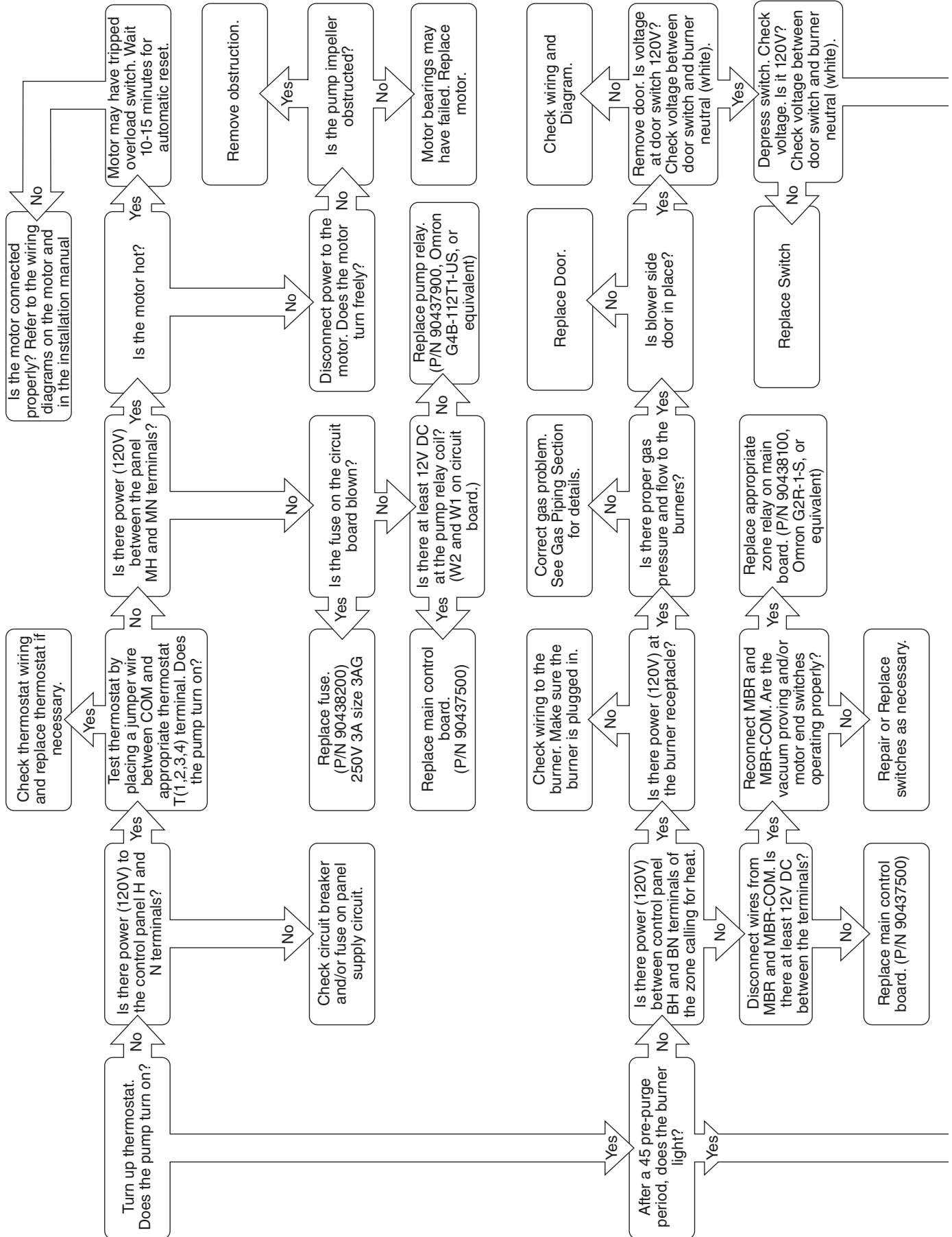

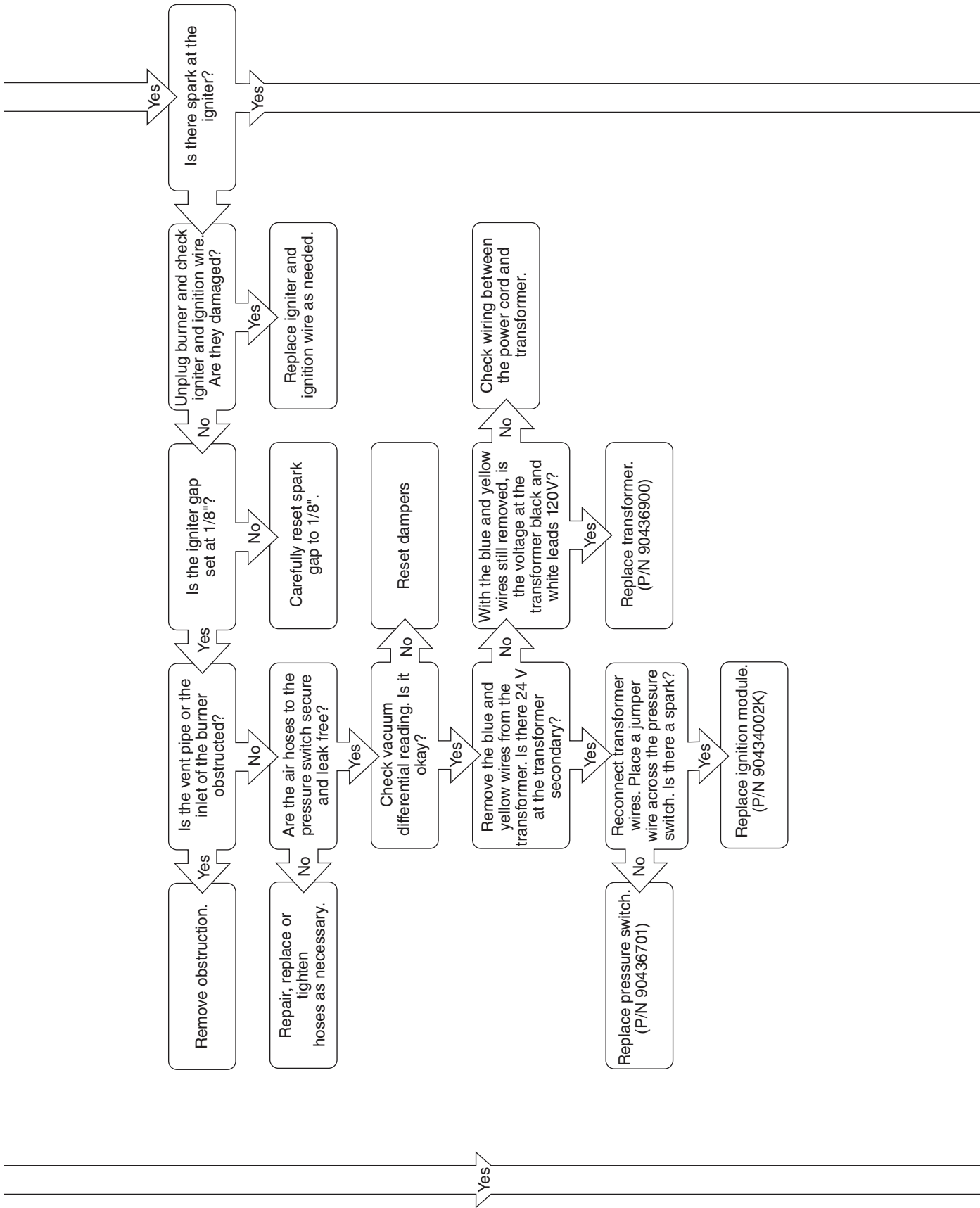

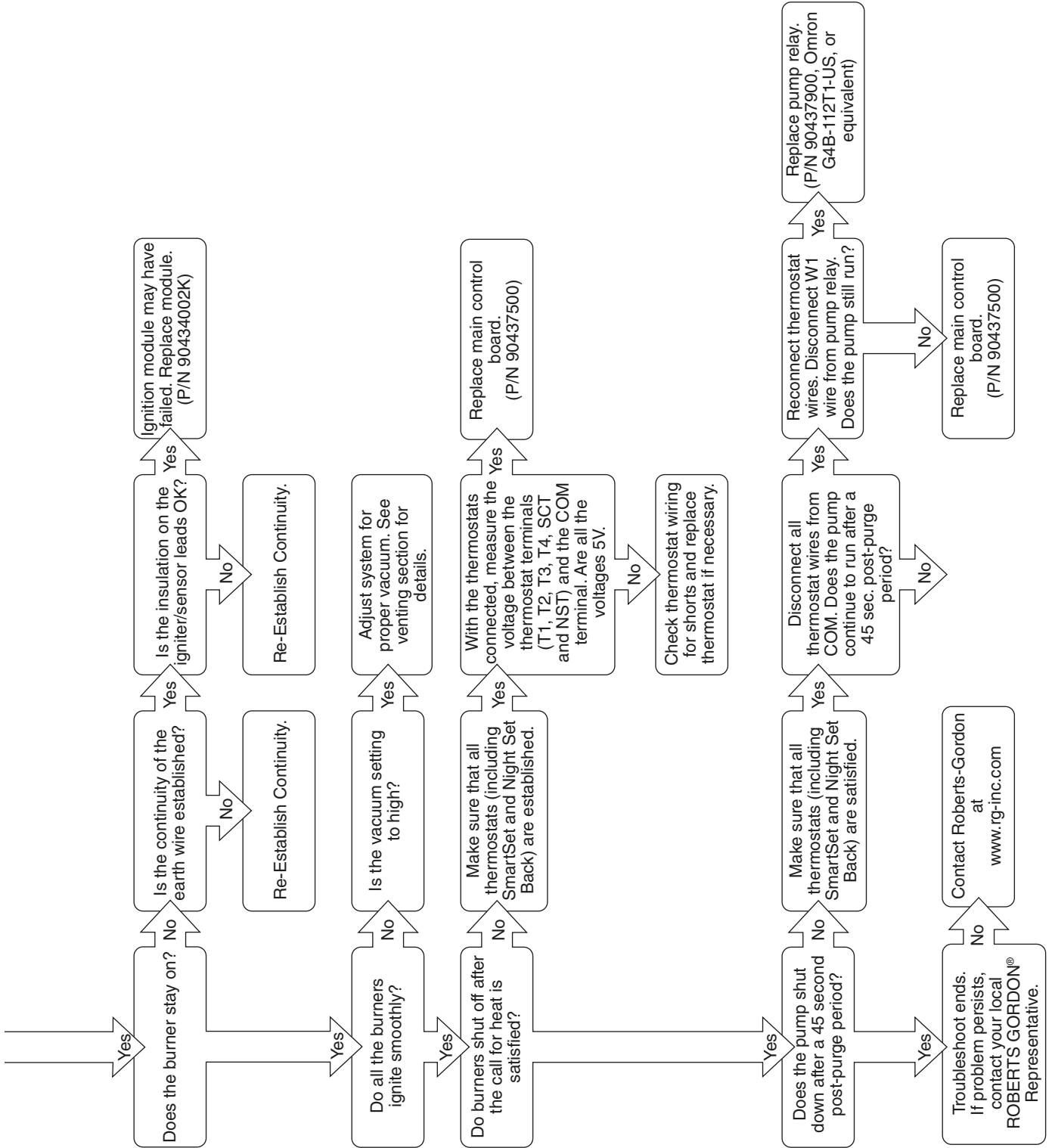

18.2 Troubleshooting Flow Chart - Multiburner

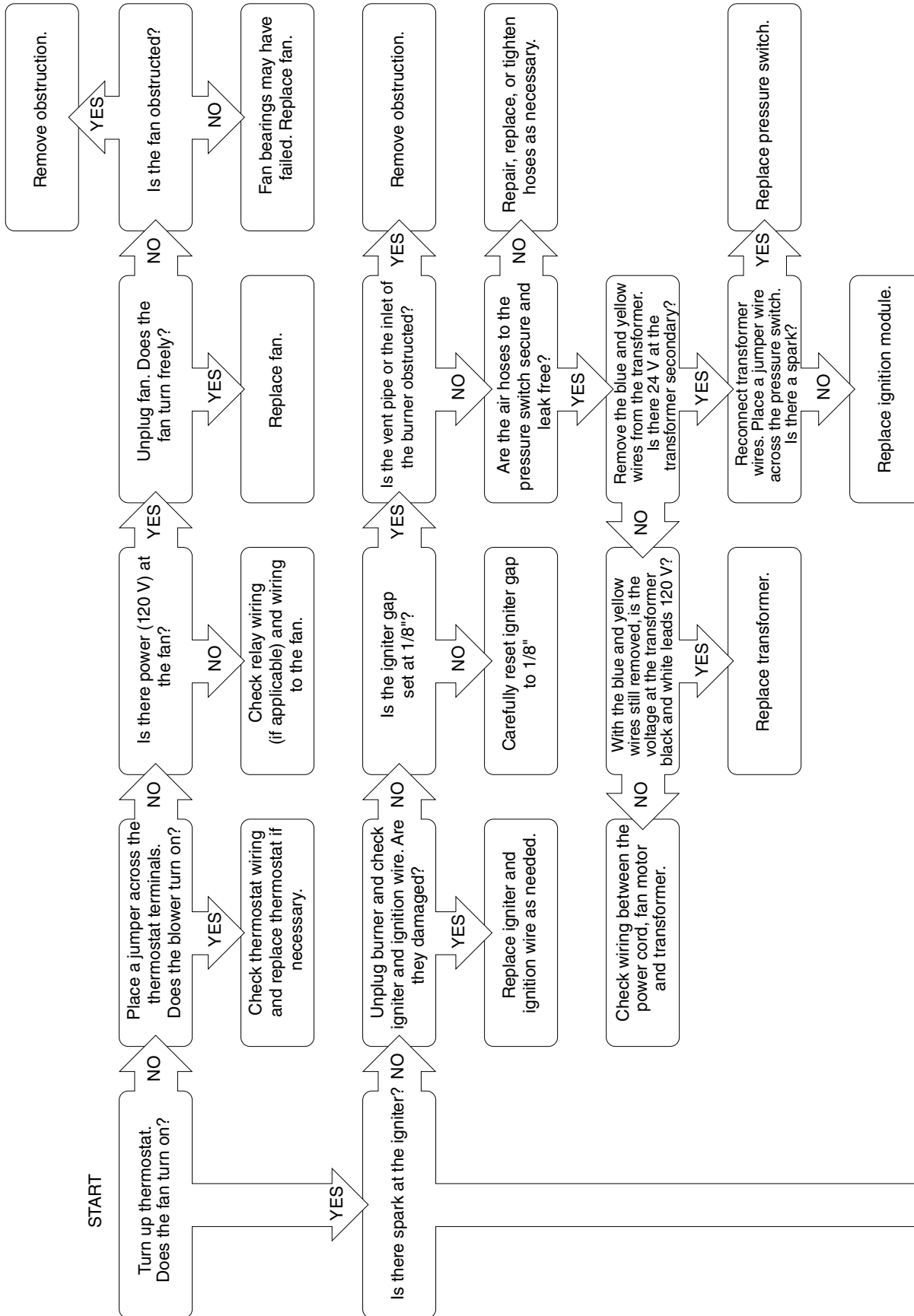

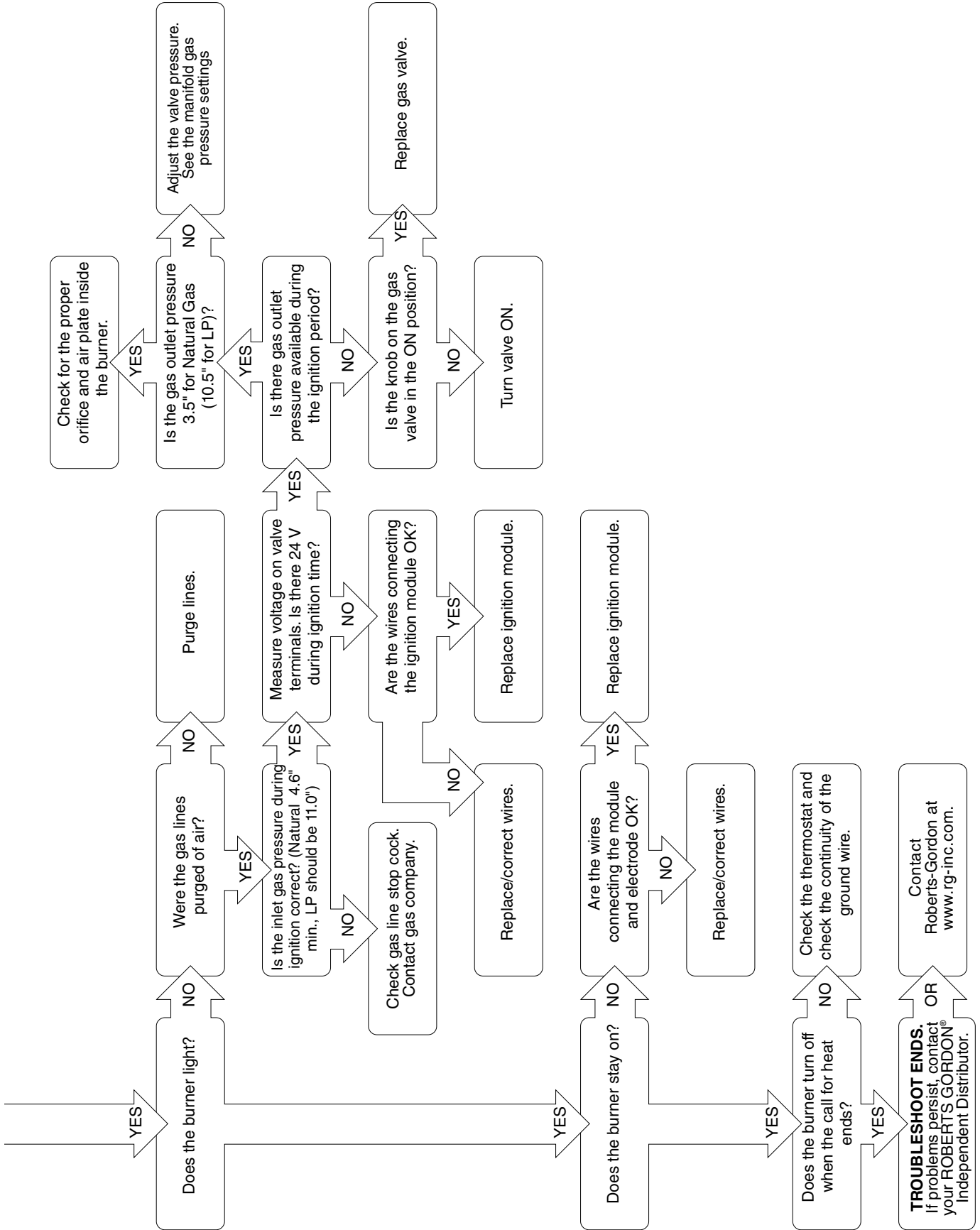



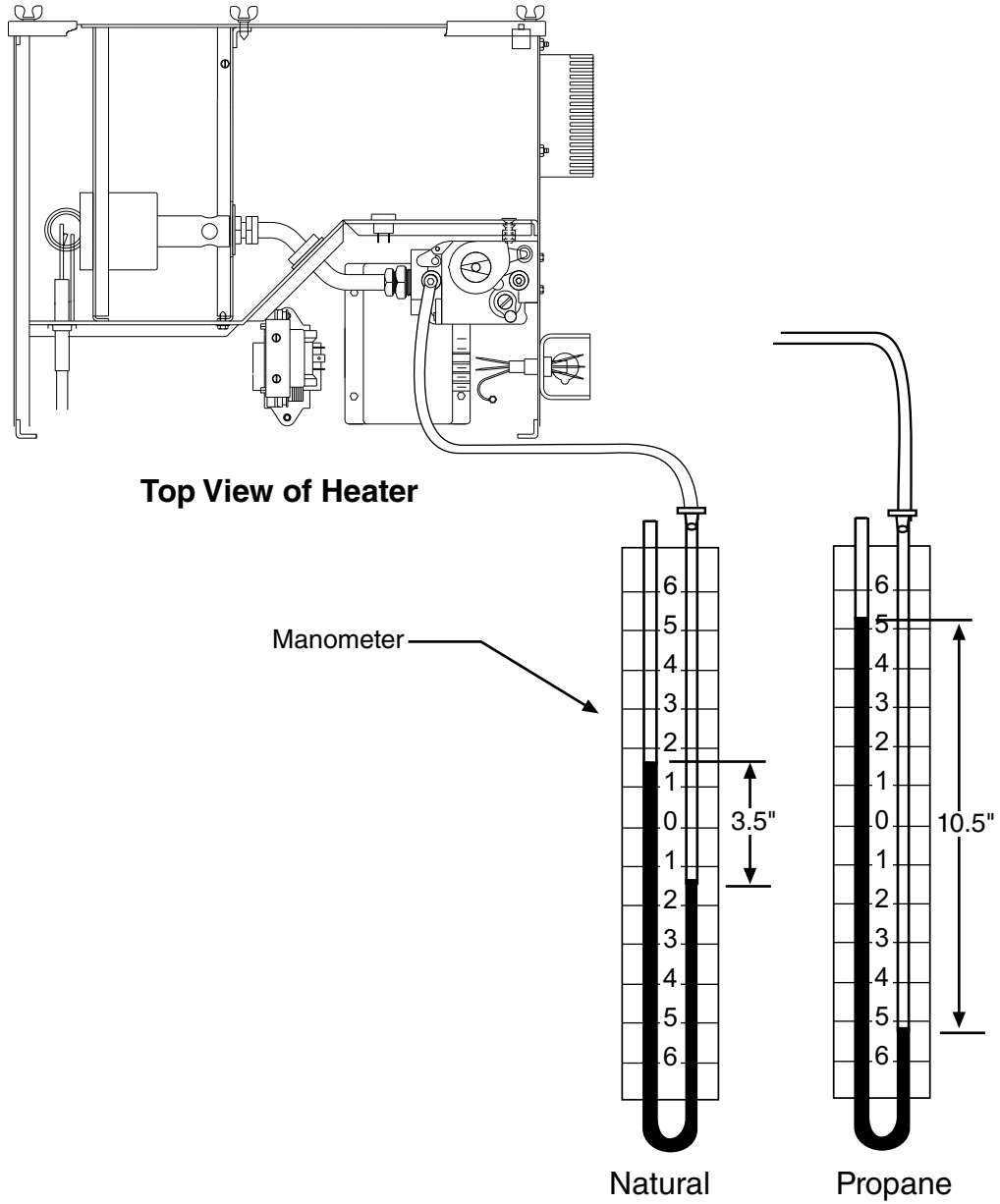

18.3 Manifold Gas Pressure Setting

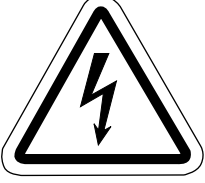

SECTION 19: REPLACEMENT PARTS LIST

⚠ DANGER		⚠ WARNING	
			
Electrical Shock Hazard	Explosion Hazard	Fire Hazard	Carbon Monoxide Hazard
Use only genuine ROBERTS GORDON® replacement parts per this installation, operation and service manual.			
Failure to follow these instructions can result in death, electric shock, injury or property damage.			

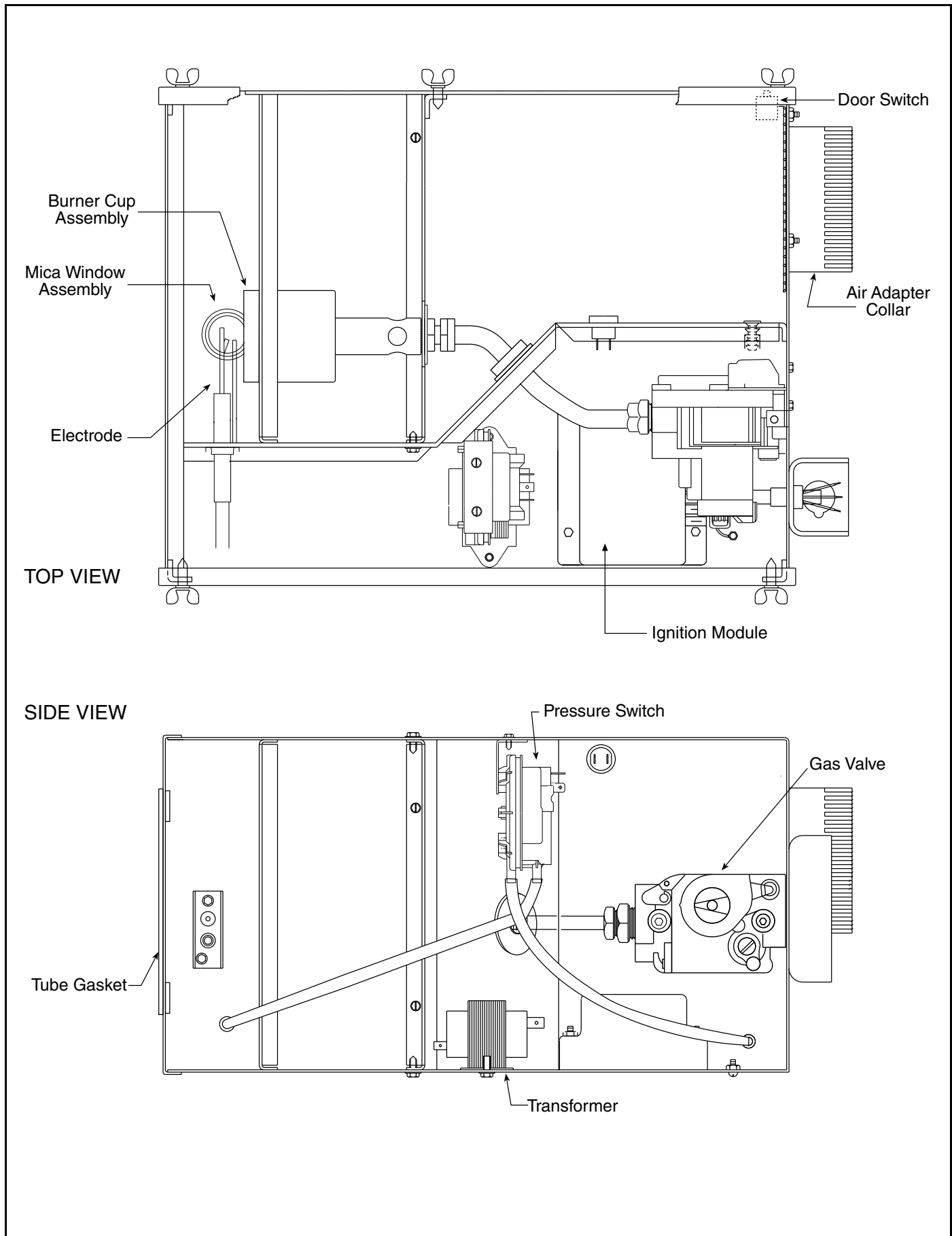

Replacement Parts List (continued)*

Description	Part Number
Burner	
Gas Valve (Natural)	90032500
Gas Valve (LP)	90032502
Burner Cup Assembly	03020100
Mica Window Assembly	02553203
Electrode	90427400
Electrode Gasket	02558501
Ignition Module	90439500K
Ignition Wire	90427706
Transformer	90436900K
Door Switch	90436800
Air Adapter Collar	91911700
Tube Gasket	02568200
Pressure Switch:	
(40, 80)	90439803K
(60, 100, 125, 150)	90439810K
(175, 200)	90439802K
Outside Air Supply Blower	
Air Supply Blower/Power Venter	90707501

* For all other accessories, see Page 14, Section 8.1; Page 30, Section 9.1; Page 16, Table 4 and Page 32, Table 9.

SECTION 20: GENERAL SPECIFICATIONS

20.1 Material Specifications

20.1.1 Reflectors

.024 Aluminum
(Optional .024 Stainless Steel Type 304)

20.2 Heater Specifications

20.2.1 Control System

Fully automatic, three-try, direct spark, electronic ignition control, 100% safety shut-off.

20.3 Suspension Specifications

Hang heater with materials with a minimum working load of 75 lbs (33 kg). See Page 13, Figure 14.

20.4 Controls Specifications

Time switches, thermostats, etc. can be wired into the electrical supply. External controls supplied as an optional extra.

General Specifications for the heaters are as follows:

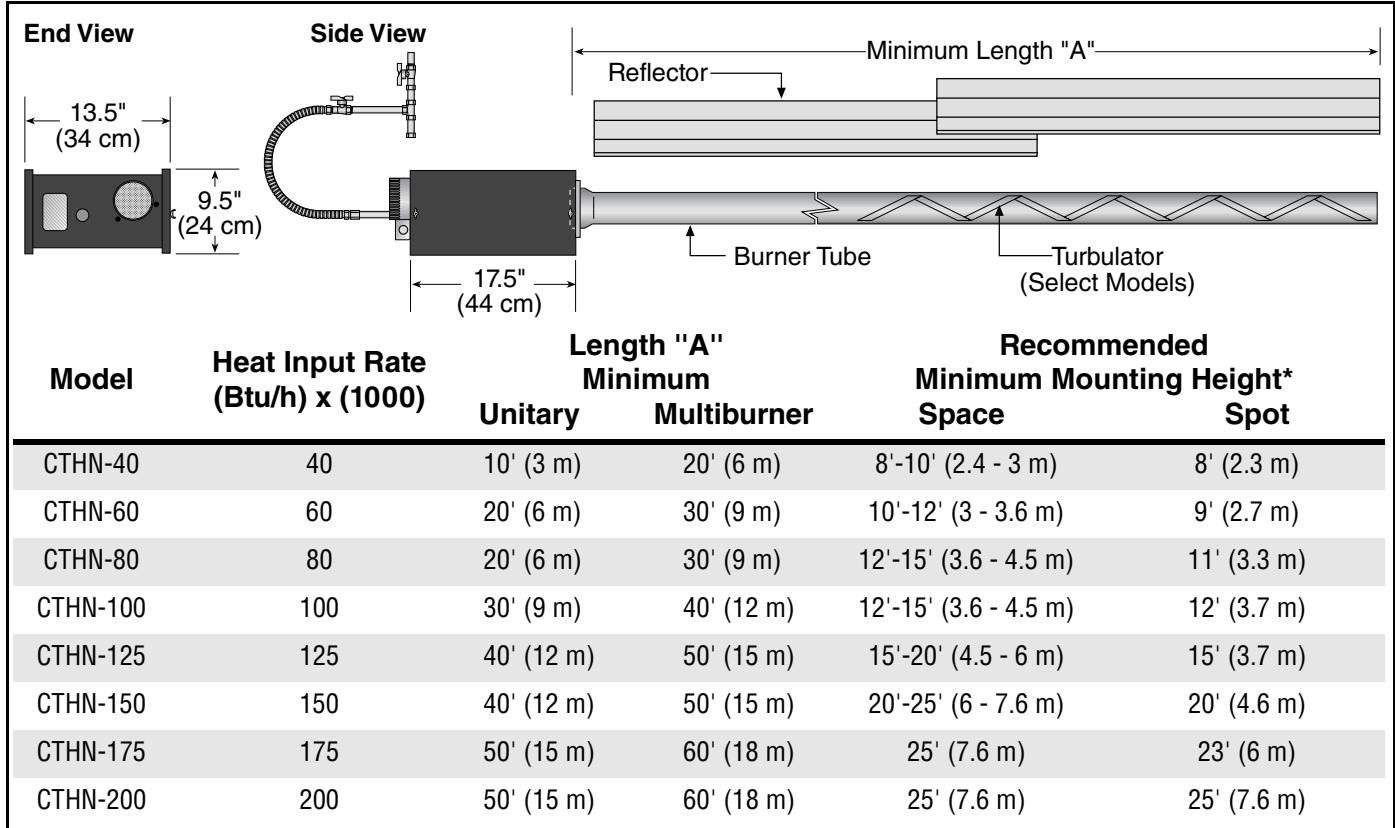

*See Page 5, Section 3 for clearances to combustibles.

GAS PRESSURE AT MANIFOLD:

Natural Gas: 3.5" wc
LP Gas: 10.5" wc

PIPE CONNECTION:

1/2" NPT (for CTHN-40, 60, 80, 100, 125)
3/4" NPT (for CTHN-150,175 & 200)

DIMENSIONS:

Vent Connection Size: 4" (10 cm)
Outside Air Connection Size: 4" (10 cm)
Refer to figure above for dimensional information.

GAS INLET PRESSURE:

Natural Gas:
for CTHN-40, 60, 80, 100, 125, 150 4.6" wc Minimum
for CTHN-175, 200 5.0" wc Minimum
14.0" wc Maximum
LP Gas: All Models 11.0" wc Minimum
14.0" wc Maximum

ELECTRICAL RATING:

Unitary Models 40-150: 120 V - 60 Hz, 1 A
Unitary Models 175-200: 120 V - 60 Hz, 2 A
Multiburner All Models: 120 V - 60 Hz, 0.1 A

General Specifications for fans and pumps are as follows:

Pump Dimensional Data (in.)

Model	A	B	C	D	E	F	G
EP-100	17	14.5	21	3.75	10	4	4
EP-201/203	17.75	17	20.25	3.25	10	4.5	4.5
EP-301/303	25.6	24.8	22.7	4.8	15.2	6	6

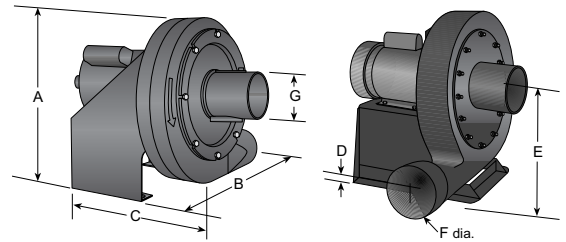

Fan and Pump Specifications

Model	05220000	05221000	EP-100	EP-201	EP-203	EP-301	EP-303
Horsepower (Hp)	.134	.23	1/3	3/4	3/4	2*	2*
Phase (Ø)	1	1	1	1	3	1	3
Hertz (Hz)	60	60	60	60	60	60	60
Voltage (V)	115	115	115/230	115/230	208-230/ 460	208-230	208-230/ 460
Full Load Amp (Amps)	.9	1.6	4.8/2.4	6.6/3.3	2.4-2.2/1.1	12.8-11.5	5.5-5.2/2.6
R.P.M.	3200	3200	3450	3450	3500	3450	3450
Motor Frame	-	-	56	56	56	90	90
Motor Enclosure	-	-	TENV	TENV	TEFC	TEFC	TEFC
Noise Level @ 5' (DBA)	-	-	-	70	70	-	-
Inlet/Outlet (In.)	4/4	4/4	4/4	4/4	4/4	6/6	6/6
Weight (lbs.)	10	12	62	112	112	170	170

* For starter, see National Electric Code (NEC) requirement for motors 1 hp or higher.

Air Supply Blower Specifications

Capacity	240 CFM @ 0.75 in wc
Power (W)	167
Phase	1
Hertz (Hz)	60
Voltage (V)	120
Full Load Amp (Amps)	1.5
R.P.M.	3000
Motor Enclosure	OPEN FC
Inlet/Outlet (In.)	5/5
Weight (lbs.)	10

SECTION 21: THE ROBERTS GORDON® BLACKHEAT™ NP LIMITED WARRANTY**ROBERTS-GORDON LLC WILL PAY FOR:**

Within 36 months from date of purchase by buyer or 42 months from date of shipment by Roberts-Gordon LLC (whichever occurs first), replacement parts will be provided free of charge for any part of the product which fails due to a manufacturing or material defect.

Roberts-Gordon LLC will require the part in question to be returned to the factory. Roberts-Gordon LLC will, at its sole discretion, repair or replace after determining the nature of the defect and disposition of part in question.

ROBERTS GORDON® Replacement Parts are warranted for a period of 12 months from date of shipment from Roberts-Gordon LLC or the remaining ROBERTS GORDON® BLACKHEAT™ NP warranty.

ROBERTS-GORDON LLC WILL NOT PAY FOR:

Service trips, service calls and labor charges.

Shipment of replacement parts.

Claims where the total price of the goods have not been paid.

Damage due to:

- Improper installation, operation or maintenance.
- Misuse, abuse, neglect, or modification of the ROBERTS GORDON® BLACKHEAT™ NP in any way.
- Use of the ROBERTS GORDON® BLACKHEAT™ NP for other than its intended purpose.
- Incorrect gas or electrical supply, accident, fire, floods, acts of God, war, terrorism, or other casualty.
- Improper service, use of replacement parts or accessories not specified by Roberts-Gordon.
- Failure to install or maintain the ROBERTS GORDON® BLACKHEAT™ NP as directed in the Installation, Operation and Service manual.
- Relocation of the ROBERTS GORDON® BLACKHEAT™ NP after initial installation
- The use of the ROBERTS GORDON® BLACKHEAT™ NP in a corrosive atmosphere containing contaminants.
- The use of the ROBERTS GORDON® BLACKHEAT™ NP in the vicinity of a combustible or explosive material.
- Any defect in the ROBERTS GORDON® BLACKHEAT™ NP arising from a drawing, design, or specification supplied by or on behalf of the consumer.
- Damage incurred during shipment. Claim must be filed with carrier.

WARRANTY IS VOID IF:

The ROBERTS GORDON® BLACKHEAT™ NP is not installed by an contractor qualified in the installation and service of gas fired heating equipment.

You cannot prove original purchase date and required annual maintenance history.

The data plate and/or serial number are removed, defaced, modified or altered in any way.

The ownership of the ROBERTS GORDON® BLACKHEAT™ NP is moved or transferred. This warranty is nontransferable.

Roberts-Gordon LLC is not permitted to inspect the damaged equipment and/or component parts.

READ YOUR INSTALLATION, OPERATION AND SERVICE MANUAL.

If you have questions about your equipment, contact your installing professional. Should you need Replacement Parts or have additional questions, call or write:

Roberts-Gordon LLC

1250 William Street

P.O. Box 44

Buffalo, New York 14240-0044

Telephone: +1.716.852.4400

Fax: +1.716.852.0854

Toll Free: 800.828.7450

www.rg-inc.com

www.radiantheaters.com

Roberts-Gordon LLC's liability, and your exclusive remedy, under this warranty or any implied warranty (including the implied warranties of merchantability and fitness for a particular purpose) is limited to providing replacement parts during the term of this warranty. Some jurisdictions do not allow limitations on how long an implied warranty lasts, so this limitation may not apply to you. There are no rights, warranties or conditions, expressed or implied, statutory or otherwise, other than those contained in this warranty.

Roberts-Gordon LLC shall in no event be responsible for incidental or consequential damages or incur liability for damages in excess of the amount paid by you for the ROBERTS GORDON® BLACKHEAT™ NP.

Some jurisdictions do not allow the exclusion or limitation of incidental or consequential damages, so this limitation or exclusion may not apply to you. This warranty gives you specific legal rights, and you may also have other rights which vary from jurisdiction to jurisdiction.

Roberts-Gordon LLC shall not be responsible for failure to perform under the terms of this warranty if caused by circumstances out of its control, including but not limited to war, fire, flood, strike, government or court orders, acts of God, terrorism, unavailability of supplies, parts or power. No person is authorized to assume for Roberts-Gordon LLC any other warranty, obligation or liability.

LIMITATIONS ON AUTHORITY OF REPRESENTATIVES:

No representative of Roberts-Gordon LLC, other than an Executive Officer, has authority to change or extend these provisions. Changes or extensions shall be binding only if confirmed in writing by Roberts-Gordon LLC's duly authorized Executive Officer.



OWNER WARRANTY REGISTRATION CARD

Mail or Fax to:
Roberts Gordon LLC • 1250 William Street, P.O. Box 44 • Buffalo, NY 14240-0044 • Phone: 716-852-4400 • Fax: 716-852-0854
Toll Free: 800-828-7450 • www.rg-inc.com

About the Owner:

Name: _____
Address: _____ City: _____ State: _____ Zip Code: _____
Phone: _____ Fax: _____ E-mail: _____

About the Installer:

Name: _____
Address: _____ City: _____ State: _____ Zip Code: _____
Phone: _____ Fax: _____ E-mail: _____

Purchased From (if different than installer):

Name: _____
Address: _____ City: _____ State: _____ Zip Code: _____
Phone: _____ Fax: _____ E-mail: _____

About your Heater:

Model#: _____ Serial #: _____ Fuel: _____ Installation Date: _____

Type of Installation (check one):

- Automotive Manufacturing Warehouse Recreational Aircraft
- Public Building Office Retail Agricultural Other _____

Installation Code and Annual Inspections: All installation and service of ROBERTS GORDON® equipment must be performed by a contractor qualified in the installation and service of equipment sold and supplied by Roberts-Gordon LLC and conform to all requirements set forth in the ROBERTS GORDON® manuals and all applicable governmental authorities pertaining to the installation, service, operation and labeling of the equipment.

To help facilitate optimum performance and safety, Roberts-Gordon LLC recommends that a qualified contractor conduct, at a minimum, annual inspections of your ROBERTS GORDON® equipment and perform service where necessary, using only replacement parts sold and supplied by Roberts-Gordon LLC.

These products are not for residential use.

This product is intended to assist licensed professionals in the exercise of their professional judgment.

© 2012 Roberts-Gordon LLC - All rights reserved. No part of this work covered by the copyrights herein may be reproduced or copied in any form or by any means – graphic, electronic, or mechanical, including photocopying, recording, taping, or information storage and retrieval systems – without written permission of Roberts Gordon LLC. Printed in the U.S.A.

Attach this information to a wall near the ROBERTS GORDON® heater.



Read the Installation, Operation, and Service Manual thoroughly before installation, operation, or service.

Know your model number and installed configuration.

Model number and installed configuration are found on the burner and in the Installation, Operation and Service Manual.

Write the largest clearance dimensions with permanent ink according to your model number and configuration in the open spaces below.

OPERATING INSTRUCTIONS

1. STOP! Read all safety instructions on this information sheet.
2. Open the manual gas valve in the heater supply line.
3. Turn on electric power to the heater.
4. Set the thermostat to desired setting.

TO TURN OFF THE HEATER

1. Set the thermostat to off or the lowest setting.

IF THE HEATER WILL NOT OPERATE, TO ENSURE YOUR SAFETY, FOLLOW THESE INSTRUCTIONS TO SHUT DOWN YOUR HEATER

1. Set the thermostat to off or the lowest setting.
2. Turn off electric power to the heater.
3. Turn off the manual gas valve in the heater supply line.
4. Call your registered installer/contractor qualified in the installation and service of gas-fired heating equipment.

⚠ WARNING



Fire Hazard

Keep all flammable objects, liquids and vapors the minimum required clearances to combustibles away from heater.

Some objects will catch fire or explode when placed close to heater.

Failure to follow these instructions can result in death, injury or property damage.

**Maintain _____ clearance
to the side and
_____ clearance below
the heater from vehicles
and combustible materials.**

Roberts-Gordon LLC
1250 William Street
P.O. Box 44
Buffalo, NY 14240-0044 USA
Telephone: +1.716.852.4400
Fax: +1.716.852.0854
Toll Free: 800.828.7450

Roberts-Gordon Europe Limited
Unit A, Kings Hill Business Park
Darlaston Road, Wednesbury
West Midlands WS10 7SH UK
Telephone: +44 (0)121 506 7700
Fax: +44 (0)121 506 7701

Service Telephone: +44 (0)121 506 7709
Service Fax: +44 (0)121 506 7702
E-mail: uksales@rg-inc.com
E-mail: export@rg-inc.com

Installation Code and Annual Inspections:

All installation and service of ROBERTS GORDON® equipment must be performed by a contractor qualified in the installation and service of equipment sold and supplied by Roberts-Gordon and conform to all requirements set forth in the ROBERTS GORDON® manuals and all applicable governmental authorities pertaining to the installation, service, operation and labeling of the equipment. To help facilitate optimum performance and safety, Roberts-Gordon recommends that a qualified contractor conduct, at a minimum, annual inspections of your ROBERTS GORDON® equipment and perform service where necessary, using only replacement parts sold and supplied by Roberts-Gordon.

Further Information: Applications, engineering and detailed guidance on systems design, installation and equipment performance is available through ROBERTS GORDON® representatives. Please contact us for any further information you may require, including the Installation, Operation and Service Manual.

This product is not for residential use.

© 2012 Roberts-Gordon LLC

All rights reserved. No part of this work covered by the copyrights herein may be reproduced or copied in any form or by any means – graphic, electronic, or mechanical, including photocopying, recording, taping, or information storage and retrieval systems – without written permission of Roberts-Gordon LLC.

www.rg-inc.com

Printed in U.S.A.

P/N 91037912 Rev. J