

Blackheat™ GH

Gas-Fired, Low-Intensity Infrared Heaters for Light Industrial/Commercial Applications

Installation, Operation & Service Manual

FOR YOUR SAFETY

If you smell gas:

1. Open windows.
2. **DO NOT** try to light any appliance.
3. **DO NOT** use electrical switches.
4. **DO NOT** use any telephone in your building.
5. Extinguish any open flame.
6. Leave the building.
7. Immediately call your local gas supplier after leaving the building. Follow the gas supplier's instructions.
8. If you cannot reach your gas supplier, call the Fire Department.

⚠ WARNING



Fire Hazard

Keep all flammable objects, liquids and vapors the minimum required safe distances to combustibles away from heater.

Some objects will catch fire or explode when placed close to heater.

Failure to follow these instructions can result in death, injury or property damage.



CGTH-30
CGTH-40
CGTH-50

⚠ WARNING

Improper installation, adjustment, alteration, service or maintenance can result in death, injury or property damage. Read the Installation, Operation and Service Manual thoroughly before installing or servicing this equipment.

Installation must be done by a contractor qualified in the installation and service of gas-fired heating equipment or your gas supplier.

Installer

Please take the time to read and understand these instructions prior to any installation. Installer must give a copy of this manual to the owner.

Owner

Keep this manual in a safe place in order to provide your serviceman with necessary information.



Roberts-Gordon LLC

1250 William Street
P.O. Box 44
Buffalo, New York 14240-0044
Telephone: +1.716.852.4400
Fax: +1.716.852.0854
Toll Free: 800.828.7450

www.rg-inc.com

TABLE OF CONTENTS

SECTION 1: Before You Begin	1	SECTION 9: Venting Installation	27
1.1 Heater Safety	1	9.1 General Venting Requirements.....	27
1.2 Questions, Comments or Suggestions.....	1	9.2 Install Galvanized Collar	28
SECTION 2: Introduction	2	9.3 Galvanized Horizontal Venting.....	28
2.1 About Roberts-Gordon LLC	2	9.4 Cox Geelen Horizontal Venting.....	32
2.2 About the Heater.....	2	9.5 Cox Geelen Vertical Venting	34
2.3 Unpacking the Heater	2	SECTION 10: Electrical Service Installation	36
2.4 Safety Labels and Their Placement.....	2	10.1 System Requirements.....	36
2.5 California Proposition 65.....	2	10.2 Grounding	36
SECTION 3: Component Identification	5	10.3 Important Notes	36
3.1 Carton Contents of Heaters with Galvanized Venting.....	5	10.4 Thermostat Placement.....	36
3.2 Carton Contents of Heaters with Cox Geelen Venting.....	6	10.5 Thermostat Installation	36
3.3 Available Accessories for Galvanized Vent	7	10.6 Connection Diagram	38
3.4 Available Accessories for Cox Geelen Vent	8	SECTION 11: Gas Service Installation	40
3.5 Component Description	9	11.1 Install Gas Supply Lines	40
SECTION 4: Technical Specifications	10	SECTION 12: Operation	41
4.1 Material Specifications.....	10	12.1 Operating Instructions.....	41
4.2 Heater Specifications.....	10	12.2 To Turn Off Gas To Heater	41
4.3 Suspension Specifications.....	10	12.3 Sequence of Operation.....	41
4.4 Controls Specifications	10	12.4 Testing	42
SECTION 5: Installation Considerations	11	SECTION 13: Troubleshooting	43
5.1 Where Can the Heater Be Installed?	11	13.1 General	44
5.2 Where Can't the Heater Be Installed?.....	11	SECTION 14: Maintenance	48
5.3 Installer's Responsibility	11	14.1 Pre-Season Maintenance and Annual Inspection	48
5.4 Thermostat Tag.....	11	SECTION 15: Replacement Parts	50
SECTION 6: Heater Installation Requirements	12	15.1 Replacement Parts List for Burner.....	52
6.1 National Standards and Applicable Codes	12	15.2 Illustrated Parts List for Tube and Reflector	53
6.2 Gas Service Requirements.....	12	15.3 Replacement Parts List for Tube & Reflector	53
6.3 Electrical Service Requirements.....	12	SECTION 16: The ROBERTS GORDON® BLACKHEAT™ GH Warranty	55
6.4 Venting Requirements.....	13		
6.5 Non-Residential Installations	13		
SECTION 7: Required Safe Distances From Combustibles	15		
SECTION 8: Installation	17		
8.1 Safety Equipment	17		
8.2 Installation Tools	17		
8.3 Installation Materials	17		
8.4 Choose Location for Heater	18		
8.5 General Venting Guidelines	18		
8.6 Hang the Heater	21		
8.7 Remove Shipping Screw from Control Housing Door.....	21		
8.8 Heater Assembly	22		
8.9 Typical Installation.....	23		
8.10 Heater Orientation.....	23		
8.11 Horizontal Installation.....	23		
8.12 45° Tilted Installation.....	24		
8.13 Grille Installation (for Select Models Only).....	25		

© 2012 Roberts-Gordon LLC

All rights reserved. No part of this work covered by the copyrights herein may be reproduced or copied in any form or by any means - graphic, electronic, or mechanical, including photocopying, recording, taping or information storage and retrieval systems - without the written permission of Roberts-Gordon LLC.

TABLE OF FIGURES

Figure 1: Bottom and Side Panel Label Placement.....	3
Figure 2: Control Side and Back Panel Label Placement	4
Figure 3: Assembly Overview	9
Figure 4: Specifications.....	10
Figure 5: Balanced Flue.....	13
Figure 6: Horizontal Installations.....	16
Figure 7: 45° Tilted Installations.....	16
Figure 8: Vent Terminal Locations.....	19
Figure 9: Shipping Screw.....	21
Figure 10: Suspension Details.....	21
Figure 11: Heater Assembly	22
Figure 12: Typical Installation	23
Figure 13: Horizontal Installation.....	24
Figure 14: 45° Tilted Installation.....	24
Figure 15: Silicone Cap Installation	25
Figure 16: Grille End Cap Installation.....	25
Figure 17: Reflector and Grille	26
Figure 18: Rear View	28
Figure 19: Horizontal Installation Side View.....	29
Figure 20: Bird Screen Installation.....	29
Figure 21: Horizontal Installation Top View	30
Figure 22: Elbow Assembly End View	31
Figure 23: Elbow Assembly Cross Section View	31
Figure 24: Elbow Assembly	31
Figure 25: Elbow Assembly for Vent Collar	31
Figure 26: Vent Collar and 5" Vent Attachment	32
Figure 27: Horizontal Installation Side View Cox Geelen Venting.....	33
Figure 28: Flue Collar and Adapter.....	33
Figure 29: Horizontal Venting Configurations	33
Figure 30: Vertical Venting Configurations	34
Figure 31: Vent Clamp.....	35
Figure 32: Thermostat Installation	37
Figure 33: Thermostat Installation Rear View.....	37
Figure 34: Internal Wiring Diagram	39
Figure 35: Ladder Diagram	39
Figure 36: Gas Supply Lines.....	40
Figure 37: Pressure Testing.....	42
Figure 38: Manometer Reading	46
Figure 39: Illustrated Parts List	51
Figure 40: Tube and Reflector.....	53

LIST OF TABLES

Table 1: Components	34
Table 2: Components	34

SECTION 1: BEFORE YOU BEGIN

1.1 Heater Safety



Your Safety is Important to Us!
This symbol is used throughout the manual to notify you of possible fire, electrical or burn hazards. Please pay special attention when reading and following the warnings in these sections.

Installation, Service and Annual Inspection of heater must be done by a contractor qualified in the installation and service of gas-fired heating equipment.

Read this manual carefully before installation, operation or service of this equipment. Improper installation, service or maintenance can result in death, injury or property damage.

Check the minimum required safe distances from combustibles given on the outside of each burner to make sure that the product is suitable for your application. The minimum required safe distances from combustibles are also found *on Pages 15 and 16* of this manual. After the installation is complete, check product operation as provided in these instructions.

This heater must be applied and operated under the general concepts of reasonable use and installed using best building practices.

This appliance is not intended for use by persons (including children) with reduced physical, sensory or mental capabilities, or lack of experience and knowledge, unless they have been given supervision or instruction concerning use of the appliance by a person responsible for their safety.

Children should be supervised to ensure that they do no play with the appliance.

For additional copies of the Installation, Operation and Service Manual, please contact Roberts-Gordon LLC.

1.2 Questions, Comments or Suggestions

Please direct any questions, comments or suggestions to:

Roberts-Gordon LLC
1250 William Street
P.O. Box 44
Buffalo, New York 14240-0044
Telephone: +1.716.852.4400
Fax: +1.716.852.0854
Toll Free: 800.828.7450
www.rg-inc.com
www.radiantheaters.com

SECTION 2: INTRODUCTION

2.1 About Roberts-Gordon LLC

Roberts-Gordon LLC pioneered low-intensity infrared heating systems with the introduction of its revolutionary, custom-engineered CORAYVAC® system. With years of infrared expertise in commercial and industrial applications, Roberts-Gordon LLC offers the CGTH-Series heater for use in light industrial/commercial applications.

2.2 About the Heater

The CGTH-Series is a factory-assembled, gas-fired, low-intensity heating system that incorporates a balanced flue. The system has been designed for easy installation and can provide years of economical operation and trouble-free service. Not only is infrared heat efficient, it also provides the most comfortable conditions in open areas, such as garages.

Gas-Fired means it uses clean-burning natural or LP gas.

Low-Intensity means that the radiant surface of the tube does not glow red. Instead, it operates at a lower temperature, less than 1000° F (538° C) and radiates energy at a lower intensity per square foot of radiating surface. The lower temperature and intensity levels are within a range that is effective in establishing and maintaining personal comfort levels. An aluminum reflector directs the radiant energy downward to the occupied area.

Balanced Flue means that the burner draws combustion air from outdoors and exhausts the products of combustion, also to the outdoors, through a shared opening. This is accomplished through two concentric tubes.

Radiant refers to the energy radiated by the CGTH-Series heater. Because the energy is in the form of infrared rays, it does not directly heat the air. Instead, the rays heat objects such as the floor, cars, machines and people. The warm objects, in turn, heat the air.

These combined features are key to the comfort and fuel efficiency provided by the CGTH-Series heater.

2.3 Unpacking the Heater

2.3.1 Manpower Requirements

To prevent personal injury and damage to the heater, two persons will be required to remove the heater from the carton. Both ends of the heater should be lifted from the carton at the same time. The burner should be lifted by gripping the bottom. The reflector of the heater should be lifted using the hanger.

2.3.2 Safety

<p>WARNING</p> <p>Cut/Pinch Hazard</p> <p>Wear protective gear during installation, operation and service.</p> <p>Edges are sharp.</p> <p>Failure to follow these instructions can result in injury.</p>

Protective gear is to be worn during installation, operation and service. Thin sheet metal parts, such as the aluminum reflector portion of the heater and the various venting components, have sharp edges. To prevent injury, the use of work gloves is recommended. The use of gloves will also prevent the transfer of body oils from the hands to the surface of the reflector.

For additional copies of the Installation, Operation and Service Manual, please contact Roberts-Gordon LLC.

2.4 Safety Labels and Their Placement

Product safety signs or labels should be replaced by the product user when they are no longer legible. Please contact Roberts-Gordon LLC or your ROBERTS GORDON® independent distributor to obtain replacement signs or labels. See *Page 3, Figure 1 through Page 4, Figure 2*.

2.5 California Proposition 65

In accordance with California Proposition 65 requirements, a warning label must be placed in a highly visible location on the outside of the equipment (i.e., near equipment's serial plate). See label placement drawing on *Page 4, Figure 2* for label location. Avoid placing label on areas with extreme heat, cold, corrosive chemicals or other elements. To order additional labels, please contact Roberts-Gordon LLC or your ROBERTS GORDON® independent distributor.

FIGURE 1: Bottom and Side Panel Label Placement

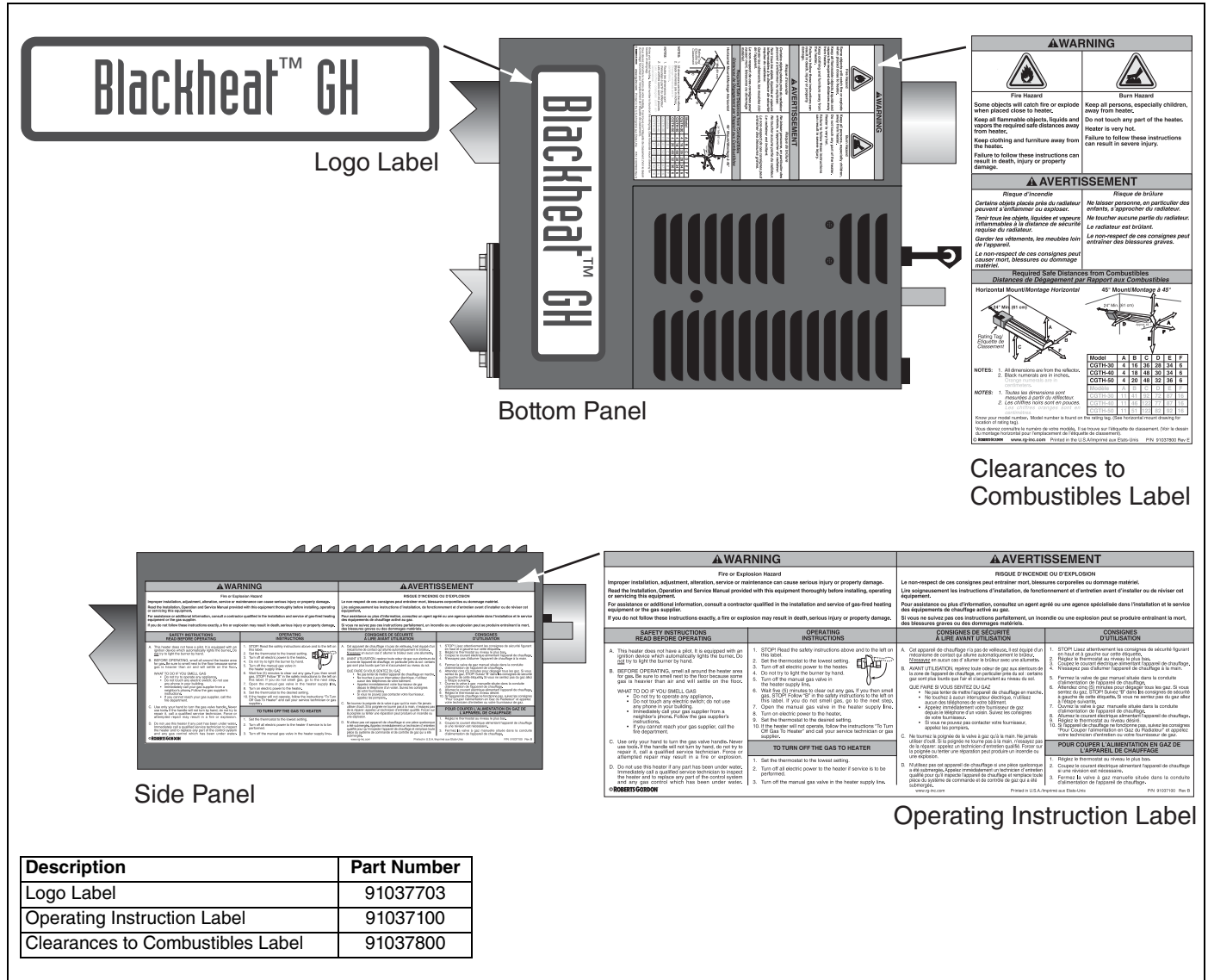

FIGURE 2: Control Side and Back Panel Label Placement

Shock Hazard Label

Wiring Diagram Label

Control Side Panel

Fire Hazard Label

Control Side Panel (Inside)

Rating Plate Label

Cord Shock Hazard Label

Proposition 65 Warning Label

Back Panel

Thermostat Connection Label

Carbon Monoxide Hazard Label

Description	Part Number
Shock Hazard Label	91037901
Wiring Diagram Label	91037600
Fire Hazard Label	91037900
Cord Shock Hazard Label	91037500
Thermostat Connection Label	91037902
Carbon Monoxide Hazard Label	91037300
Proposition 65 Warning Label	91070015

SECTION 3: COMPONENT IDENTIFICATION

3.1 Carton Contents of Heaters with Galvanized Venting

Please check the cartons. It should contain the items shown on this page. Contact your ROBERTS GORDON® independent distributor if any items are missing.

(*) Additional package included with select models; also available as an accessory. See Page 7.

Heater Assembly:

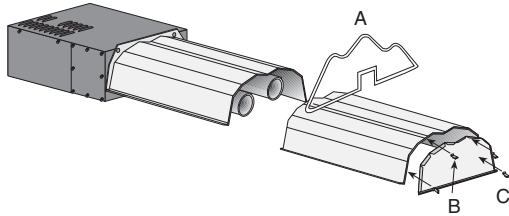

CGTH-30; CGTH-40; CGTH-50

- A.) (1) Hanger P/N 08080000
- B.) (1) Reflector End Cap P/N 02750800
- C.) (4) U-Clips P/N 91107720

* 5' (1.5 m) Balanced Flue Vent package (P/N 08039000) includes:

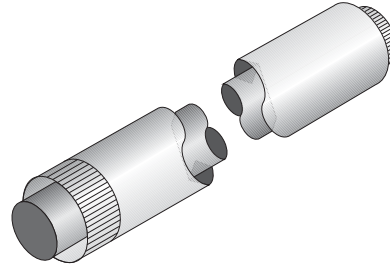

- (1) 3" (8 cm) Flue Pipe
66" (168 cm) Long
P/N 08035000
- (1) 5" (13 cm) Vent Pipe
60" (152 cm) Long
P/N 90502800

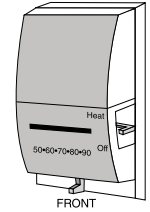

(1) Thermostat
P/N 90409702

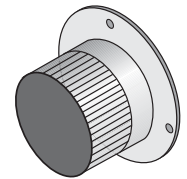

(1) Flue Collar
P/N 08031500

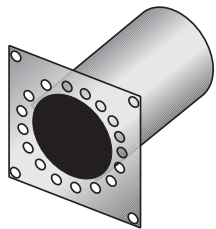

(1) Vent Termination
P/N 08031001

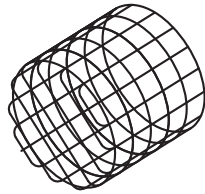

(1) Bird Screen
P/N 08036000

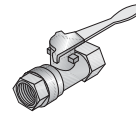

(1) 3/8" (10 mm) Manual Gas
Shut-off Valve P/N 90100200



(4) Snap Hooks
P/N 91903300

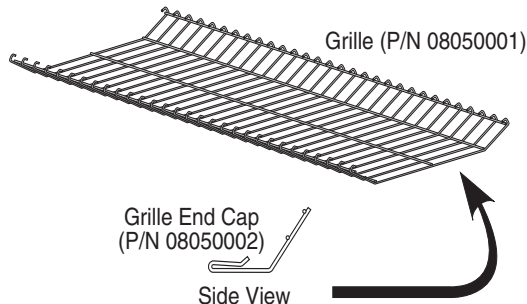

Protective Grille Kits - Included with select models. Also available as an accessory under kit part numbers.

CGTH-30 Kit (P/N 08051000) includes:

- (1) Grille End Cap P/N 08050002
- (2) Grille without End Cap P/N 08050001
- (2) Silicone Cap P/N 91915951-6P

CGTH-40 and CGTH-50 Kit (P/N 08051001) includes:

- (3) Grille without End Cap P/N 08050001
- (1) Grille End Cap P/N 08050002
- (3) Silicone Cap P/N 91915951-6P

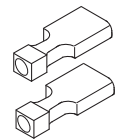
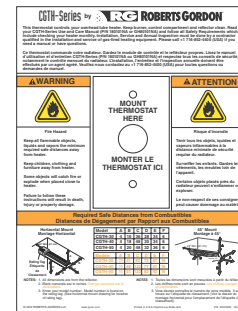

(2) Female Terminals
to connect
thermostat wire
P/N 91317300

(1) Thermostat Tag P/N 91037903

(3) Vent Collar Mounting Screws
to attach vent collar to heater
P/N 94118106

(1) Installation Manual P/N GH80100NA

(1) Use and Care Manual
P/N GH80101NA

3.2 Carton Contents of Heaters with Cox Geelen Venting

Please check the cartons. It should contain the items shown on this page. Contact your ROBERTS GORDON® independent distributor if any items are missing.

Heater Assembly:

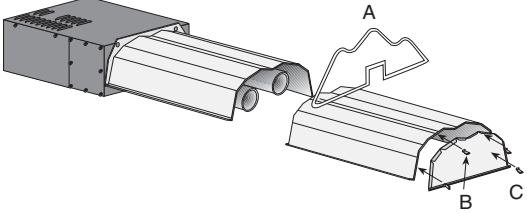

CGTH-30; CGTH-40; CGTH-50

A.) (1) Hanger P/N 08080000
 B.) (1) Reflector End Cap P/N 02750800
 C.) (4) U-Clips P/N 91107720

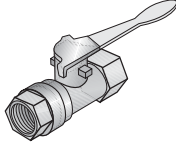

(1) 3/8" (1 cm)
 Manual Gas
 Shut-off Valve
 P/N 90100200

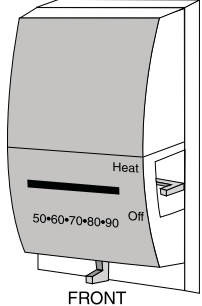

FRONT

(1) Thermostat



(4) Snap Hooks
 P/N 91903300

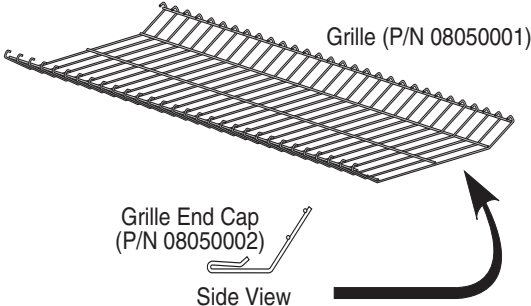

Grille (P/N 08050001)

Grille End Cap
 (P/N 08050002)
 Side View

Protective Grille Kits - Included with select models. Also available as an accessory under kit part numbers.

CGTH-30 Kit (P/N 08051000) includes:

- (1) Grille End Cap P/N 08050002
- (2) Grille without End Cap P/N 08050001
- (2) Silicone Cap P/N 91915951-6P

CGTH-40 and CGTH-50 Kit (P/N 08051001) includes:

- (3) Grille without End Cap P/N 08050001
- (1) Grille End Cap P/N 08050002
- (3) Silicone Cap P/N 91915951-6P

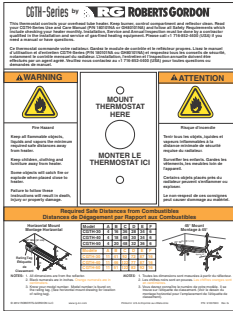
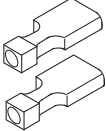
(2) Female Terminals
 to connect
 thermostat wire
 P/N 91317300

(1) Thermostat Tag P/N 91037903

(3) Vent Collar Mounting Screws
 to attach vent collar to heater
 P/N 94118106

(1) Installation Manual P/N GH80100NA
 (1) Use and Care Manual
 P/NGH80101NA

3.3 Available Accessories for Galvanized Vent

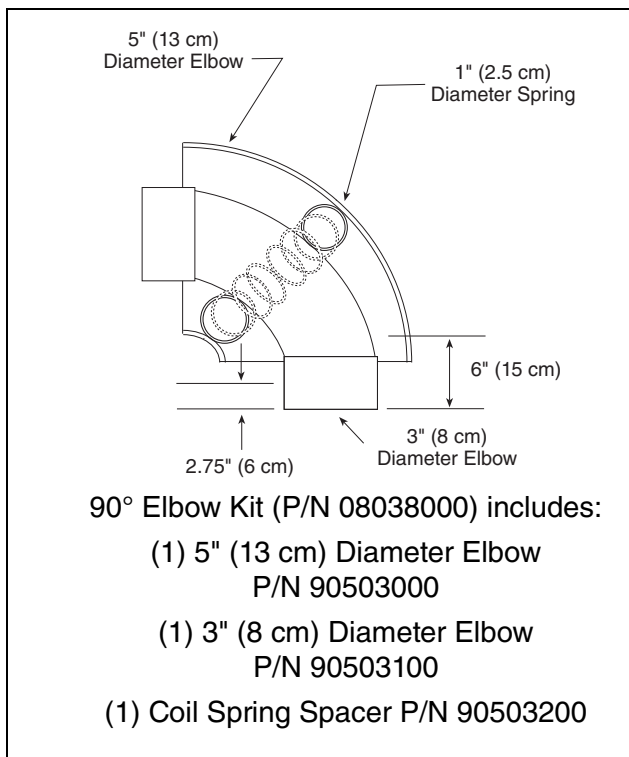
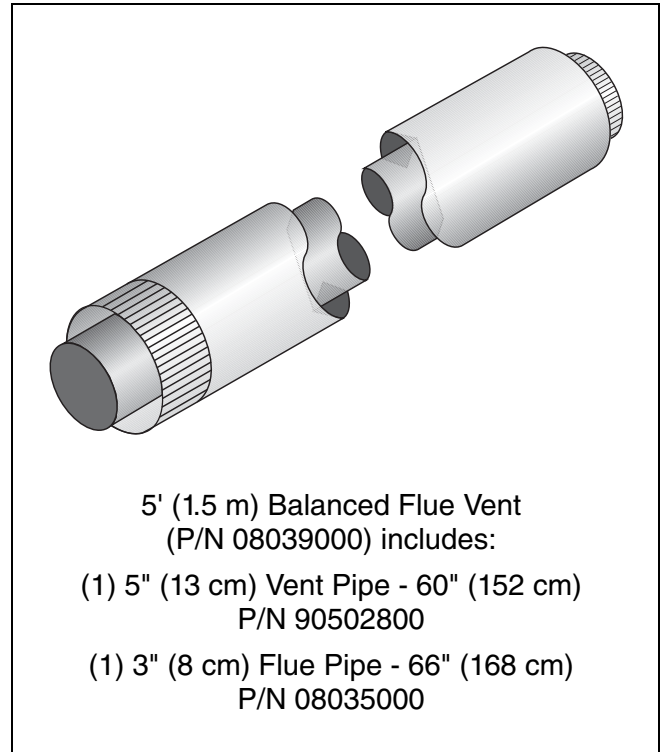
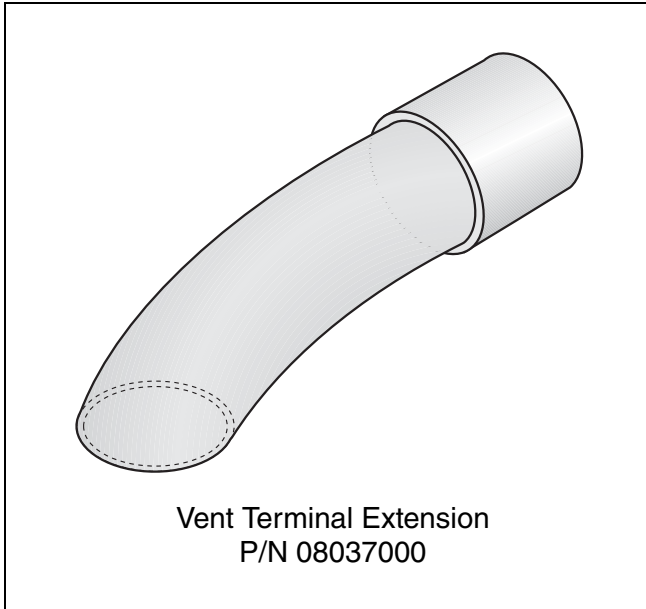

3.4 Available Accessories for Cox Geelen Vent

Roof Venting Kit (P/N 08032100) includes:



(1) Roof Terminal
50.5" (128 cm)
P/N 90506008



(1) Elbow 90°
P/N 90506001



(1) Storm Collar
P/N 90506015



(1) Burner/Vent Adapter
P/N 90506012

Wall Venting Kit (P/N 08032200) includes:



(1) Burner/Vent Adapter P/N 90506012



(1) Wall Terminal 25" (4 cm) with wall plate
(P/N 90506011) includes:
(4) Screws P/N 94118106
(2) Wall Plates P/N 90506013



- Concentric Flue - 10" (25 cm) P/N 90506003
- Concentric Flue - 20" (50 cm) P/N 90506004
- Concentric Flue - 39" (100 cm) P/N 90506005
- Concentric Flue - 79" (200 cm) P/N 90506006



Elbow 45° - 39" (100 cm) P/N 90506002

3.5 Component Description

FIGURE 3: Assembly Overview

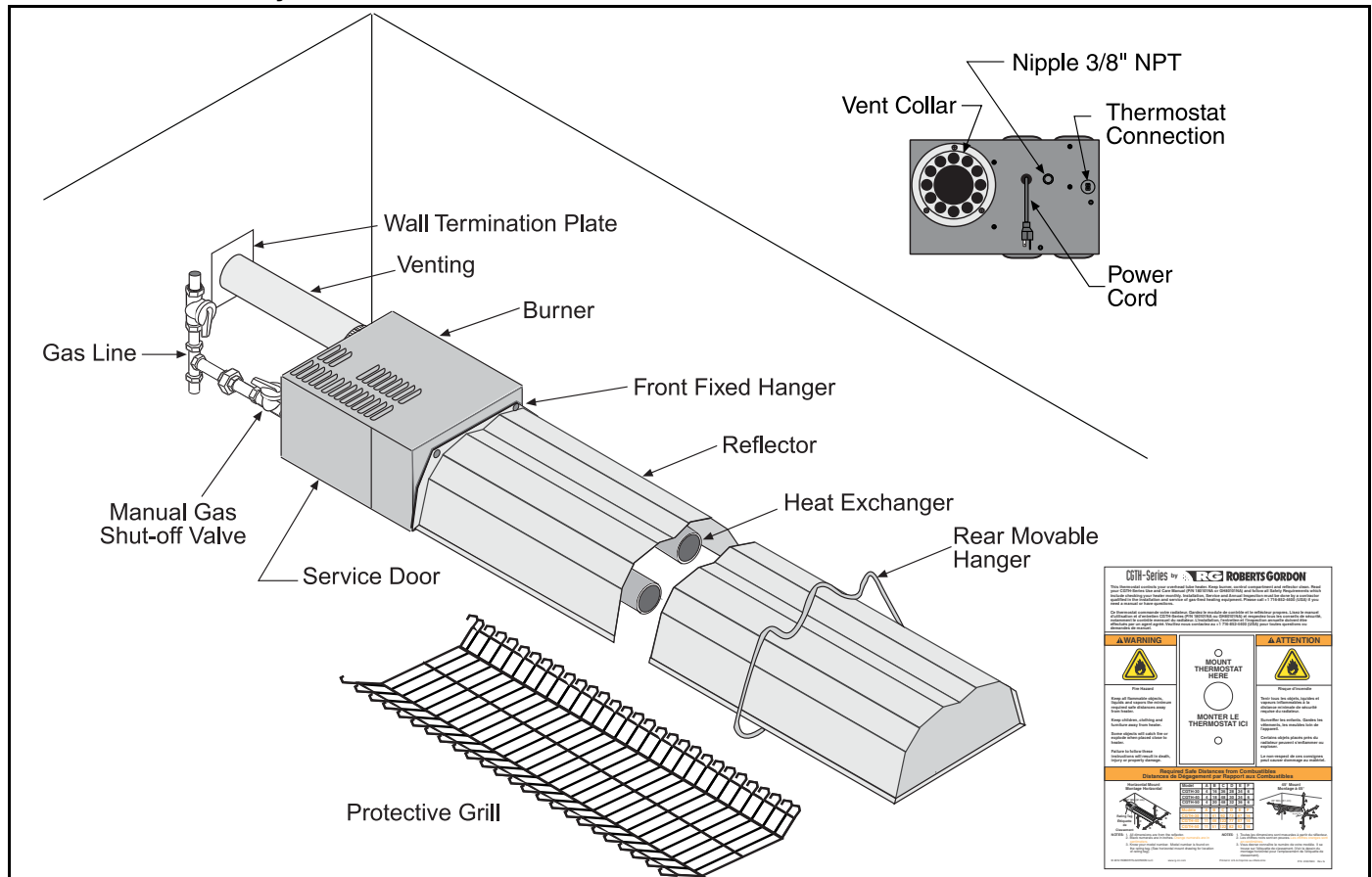

Burner - Contains the electrical components (i.e. blower motor, power transformer, etc.) and gas distribution components (i.e. gas valve, etc.) that make the heater work. There are no owner serviceable items contained in this box.

Front Fixed Hanger - Provides rigid support and mounting surface for the reflector. Holes are provided in the upper corners of the bulkhead to accommodate suspension hardware required for installation of the heater.

Reflector - The reflector is made from formed aluminum and reflects the radiant energy downward to the space to be heated.

Heat Exchanger - A U-shaped tube through which the heated products of combustion pass.

Rear Movable Hanger - Provides support for the tube and reflector at the end that is furthest from the burner. The support may be moved (within limits) to accommodate hanging of the unit.

Service Door - To be removed only by a contractor qualified in the installation and service of gas-fired heating equipment or your gas supplier. Removal of this service door provides access to the electrical and gas distribution components.

Gas Line - Must only be installed and serviced by a

licensed contractor or gas fitter.

Wall Termination Plate - Placed on the outside wall over the venting.

Venting - Installer must properly exhaust the heater outside. The 5" (13 cm) outer duct carries fresh air to the burner. The 3" (8 cm) inner duct carries the products of combustion to the outside.

Thermostat - 24 Volt thermostat mounted with Safety Tag.

Protective Grille - Included with select models. See Page 25, Section 8.13 for details.

Vent Collar - Accommodates a 5" (13 cm) diameter combustion air inlet duct that delivers fresh air to the burner. The fresh air enters the burner through the twelve equally spaced holes shown above. The 3" (8 cm) diameter hole in the center of the flue collar accommodates the venting duct that carries the products of combustion to be vented outdoors.

Nipple-3/8" NPT - Point at which the gas supply is connected to the heater.

Thermostat Connection - Two terminals to which the thermostat wires will be connected.

Power Cord - Includes a three-prong plug that must be connected to a dedicated and properly grounded three-prong ceiling outlet.

SECTION 4: TECHNICAL SPECIFICATIONS

4.1 Material Specifications

4.1.1 Reflectors

.024 Aluminum
(optional .024 Stainless Steel Type 304)

4.2 Heater Specifications

4.2.1 Ignition

Fully automatic, three try, direct spark electronic ignition control, 100% shut-off.

4.3 Suspension Specifications

Hang heater with materials with a minimum working load of 75 lbs (33 kg).

4.4 Controls Specifications

Low voltage, 24 VAC dual scale included with heater (24 VAC optional). Connection built-in receptacle on heater.

FIGURE 4: Specifications

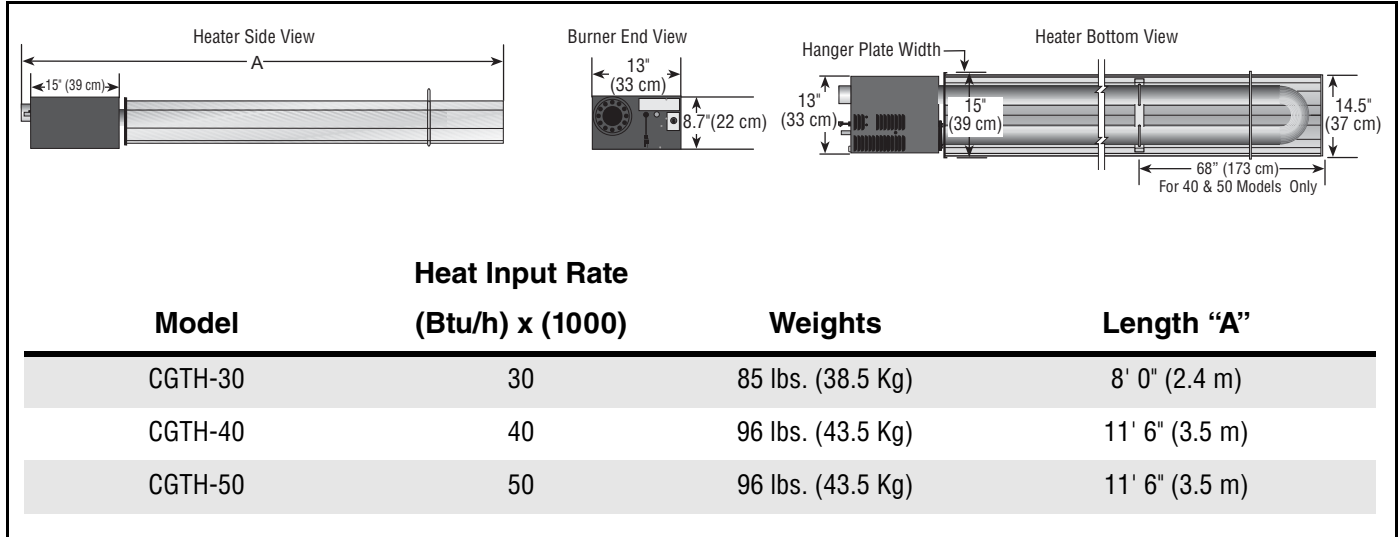

HEATER SPECIFICATIONS

ELECTRICAL

Rating: 120 V, 60 Hz, 1 Ø, 1 A
Connection: 3 pin molded plug

GAS INLET CONNECTION

Connection: 3/8" Male NPT

GAS INLET PRESSURE

Natural Gas:
Minimum: Inlet 5.0" wc (12.4 mbar)
Maximum: Inlet 14.0" wc (34.8 mbar)

LP Gas (Propane):
Minimum: Inlet 11.0" wc (37.4 mbar)
Maximum: Inlet 14.0" wc (34.8 mbar)

MANIFOLD PRESSURE

Natural Gas: 3.5" wc (8.7 mbar)
LP Gas (Propane): 10.5" wc (26.1 mbar)

VENTING SPECIFICATIONS

VENT/FLUE

Length: 10' (3 m) (Maximum)
2.5' (.7 m) (Minimum)
Flue Pipe: 3.0" (8 cm) diameter
Vent Pipe: 5.0" (13 cm) diameter

SECTION 5: INSTALLATION CONSIDERATIONS

⚠ WARNING

Fire Hazard
Keep all flammable objects, liquids and vapors the minimum required safe distances to combustibles away from heater.
Some objects will catch fire or explode when placed close to heater.
Failure to follow these instructions can result in death, injury or property damage.

5.1 Where Can the Heater Be Installed?

The CGTH-Series heater is intended for installation in the following areas:

- Residential applications, such as:
 - garages
 - hobby greenhouses
 - workshops
- Light industrial/commercial applications, such as:
 - entrance ways
 - lobby areas
 - lunch rooms
 - aircraft hangars
(See Page 13, Section 6.5.1 for restrictions)
 - public garages
(See Page 14, Section 6.5.2 for restrictions)

5.2 Where Can't the Heater Be Installed?

The CGTH-Series heater **is not intended** for installation in the following areas:

- Residential living or sleeping areas
- Basements

Due to high temperatures, ensure that the heater area is kept clear of furniture, draperies, clothing or other combustible materials. Children and adults should be alerted to the hazard of high surface temperatures and should stay away to avoid burns and clothing ignition. Young children should be carefully supervised when they are in the same room as the heater.

5.3 Installer's Responsibility

The CGTH-Series heater, the gas and electrical supplies, as well as the venting, must be installed in accordance with applicable specifications and codes. In the absence of local codes, the installation must comply with the National Fuel Gas Code ANSI 7223.1/NFPA-54, Natural Gas and Propane Installation Code, CSA B149.1. Only firms (or individuals) well qualified in this type of work should install the system. Consult local Building Inspectors, Fire Marshals or your local ROBERTS GORDON® independent distributor for guidance.

Use the information given in this manual together with the cited codes and regulations to perform the installation. The heater must be installed in accordance with the minimum required safe distances from combustibles and must be vented outside. If any aspects of the installation are unclear, consult your ROBERTS GORDON® independent distributor for clarification. The installer must furnish all needed materials that are not furnished as standard equipment. It is also the installer's responsibility to see that the materials and installation methods used result in a job that is workmanlike in appearance and is in compliance with the requirements of this manual. The installer must give this manual and the Use and Care Manual (P/N GH80101NA) to the owner.

5.4 Thermostat Tag

A laminated thermostat tag is available for the heater as a permanent reminder of the safety instructions and the importance of the minimum required safe distances from combustibles. Please contact Roberts-Gordon LLC or your ROBERTS GORDON® independent distributor to obtain the thermostat tag. Affix the tag by peeling off the backing of the adhesive strips on the rear surface and position the tag on a wall behind the thermostat.

A copy of the thermostat tag (P/N 91037903) is illustrated on Page 37, Figure 32.

Know your model number and installed configuration. Model number and installed configuration are found on the burner and in the Installation, Operation and Service Manual. See Page 16, Figure 6 through Page 16, Figure 7.

SECTION 6: HEATER INSTALLATION REQUIREMENTS

6.1 National Standards and Applicable Codes

All appliances must be installed in accordance with the latest revision of the applicable standards and national codes. This refers also to the electric, gas and venting installation. Note: Additional standards for installations in Public Garages, Aircraft Hangars, etc. may be applicable.

This section provides the following information:

- Defines the gas, electric and venting requirements for the CGTH-Series heater.
- Specifies the national standards and applicable codes that apply to the gas, electric and venting requirements.
- Specifies the national standards and applicable codes that apply to non-residential installations.

6.2 Gas Service Requirements

! WARNING

Explosion Hazard
Tighten gas hose fittings to connect gas supply according to Figure 36.
Leak test all components of gas piping before operation.
Gas can leak if piping is not installed properly.
Do not high pressure test gas piping with heater connected.
Failure to follow these instructions can result in death, injury or property damage.

6.2.1 Gas Type

The type of gas appearing on the nameplate must be the type of gas used. Installation must comply with local codes and recommendations of the local gas company. United States: Refer to National Fuel Gas Code NFPA 54/ANSI Z223.1 - latest revision. Canada: Refer to Natural Gas and Propane Installation Code CSA B149.1 - latest revision.

6.2.2 Gas Supply Lines

The size of the gas supply lines must comply with

local codes and recommendations of the local gas company. United States: Refer to National Fuel Gas Code NFPA 54/ANSI Z223.1 - latest revision.

Canada: Refer to Natural Gas and Propane Installation Code CSA B149.1 - latest revision.

A 1/8" NPT plugged tap must be installed in the gas line connection immediately upstream of the burner that is farthest from the gas supply meter. The tap is required for checking system gas pressure.

6.2.3 Meter and Service

Meter and service must be large enough to handle all the heaters being installed plus any other connected load. The gas line which feeds the system must be large enough to supply the required gas with a maximum pressure drop of 1/2" wc. When gas piping is not included in the layout drawing, the local gas supplier will usually help in planning the gas piping.

6.3 Electrical Service Requirements

! DANGER

Electrical Shock Hazard
Plug heater into grounded three-prong ceiling receptacle.
Do not cut or remove the grounding prong from this plug.
Do not use with an extension cord.
Failure to follow these instructions can result in death or electrical shock.

The CGTH-Series heater requires a grounded three-prong electrical outlet to be installed within 18" of the rear surface of the heater's burner box. It is recommended that the outlet for the heater be ceiling-mounted and should be on a dedicated circuit. **DO NOT** use an electrical extension cord to operate the heater.

Heater Rating: 120 VAC, 60 hz, 1 Ø, 1 A

6.3.1 Grounding

The heater must be electrically grounded in accordance with the following codes: United States: Refer to National Electrical Code®, NFPA 70 - latest revision.

sion. Wiring must conform to the most current National Electrical Code®, local ordinances and any special diagrams furnished.

Canada: Refer to Canadian Electrical Code, CSA C22.1 Part 1 - latest revision.

6.3.2 Thermostat

It is important to note that the CGTH-Series heater is controlled by a low voltage (24V AC) thermostat supplied with the heater. The control transformer located inside the burner supplies the necessary electrical power to operate the thermostat. No other electrical power to the thermostat is required.

6.4 Venting Requirements

! WARNING

Carbon Monoxide Hazard
Heaters must be exhausted outside.
Use materials supplied.
This heater needs fresh air for safe operation and must be installed so there are provisions for adequate combustion and ventilation air.
Failure to follow these instructions can result in death or injury.

! WARNING

Cut/Pinch Hazard
Wear protective gear during installation, operation and service.
Edges are sharp.
Failure to follow these instructions can result in injury.

The CGTH-Series heater must be installed with the venting system supplied or with the optional venting

kit available from Roberts-Gordon LLC. **DO NOT** connect this heater to a separate chimney and do not common vent with any other fuel burning appliance.

The CGTH-Series heater employs a balanced flue/air venting duct system and must conform to the following length requirements:

Maximum Length: 10' (3 m)

Minimum Length: 2.5' (.7 m)

Maximum Elbows: Two with natural gas units,
one with propane gas units

6.4.1 Venting Codes

The location, size, installation and termination of vents, as well as the required safe distances from combustibles when penetrating combustible walls, must comply with local codes and recommendations of the local gas company. United States: Refer to National Fuel Gas Code NFPA 54/ANSI Z223.1 - latest revision. Canada: Refer to Natural Gas and Propane Installation Code CSA B149.1 - latest revision.

6.4.2 Balanced Flue Construction

The balanced flue consists of a 3" (8 cm) diameter flue which is concentrically positioned inside a 5" (13 cm) diameter vent pipe (See Figure 5). The 5" (13 cm) diameter vent supplies outside air for combustion while the 3" (8 cm) diameter flue carries the products of combustion from the heater.

The balanced flue is applicable for both horizontal and vertical venting arrangements. Vertical venting will require the optional roof venting kit available from Roberts-Gordon LLC.

FIGURE 5: Balanced Flue

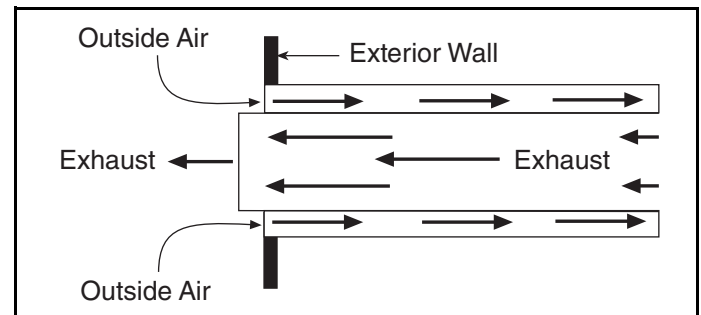

6.5 Non-Residential Installations

6.5.1 Aircraft Hangars

The CGTH-Series heater may be used in certain areas of aircraft hangars. Installation in aircraft hangars must be in accordance with the following codes: United States: Refer to Standard for Aircraft Hangars, NFPA 409 - latest revision. Canada: Refer to Natural Gas and Propane Installation Code CSA B149.1 - latest revision.

- Heaters in aircraft storage or service areas must be installed a minimum of 10' (3 m) above the upper surface of wings or engine enclosures of the highest aircraft which may be housed in the hangar. (This should be measured from the bottom of the heater to the top of the wing, or engine enclosure, whichever is highest from the floor).
- In other sections of aircraft hangars, such as shops or offices, heaters must be installed a minimum of 8' (2.4 m) above the floor.
- Heaters installed in aircraft hangars shall be located so as not to be subject to damage by aircraft, cranes, movable scaffolding or other objects.
- When installed over hoists, the required safe distances from combustibles must be maintained from the uppermost point of the combustible materials placed on the hoist.

6.5.2 Public Garages

The CGTH-Series heater may be used in public garages. Installation in public garages must be in accordance with the following codes: United States: Refer to Standard for Parking Structures NFPA 88A - latest revision or the Code for Motor Fuel Dispensing Facilities and Repair Garages, NFPA 30A - latest revision. Canada: Refer to Natural Gas and Propane Installation Code CSA B149.1 - latest revision.

- Heaters must be installed a minimum of 8' (2.4 m) above the floor. Required safe distances to combustibles must be maintained from vehicles parked below the heater.
- When installed over hoists, the required safe distances from combustibles must be maintained from the uppermost point of the combustible materials placed on the hoist.

6.5.3 High Altitude

These heaters are approved for installations up to 2000' (610 m)(US), 4500' (1370 m) (Canada) without modification. Consult factory if US installation is above 2000' (610 m) or Canadian installation is above 4500' (1370 m).

6.5.4 Hazardous Locations

Where there is the possibility of exposure to combustible airborne material or vapor, consult the local fire marshal, the fire insurance carrier or other authorities for approval of the proposed installation.

SECTION 7: REQUIRED SAFE DISTANCES FROM COMBUSTIBLES

⚠ WARNING

Fire Hazard
Keep all flammable objects, liquids and vapors the minimum required safe distances to combustibles away from heater.
Some objects will catch fire or explode when placed close to heater.
Failure to follow these instructions can result in death, injury or property damage.

⚠ WARNING

Burn Hazard
Keep all persons, especially children, away from heater.
Do not touch any part of the heater.
Heater is very hot.
Failure to follow these instructions can result in death, injury or property damage.

In all situations, the minimum required safe distances from combustibles must be maintained. Combustibles are materials which may catch fire and include many common items such as wood, paper, rubber, fabrics, etc. Combustible materials such as those noted, and any other combustible materials, must not be placed closer to any base or side of the CGTH-Series heater than the distances noted in the diagrams on the following page. If you have any questions about the required safe distances from combustibles, or the associated diagrams, please contact your installer, ROBERTS GORDON® independent distributor, or Roberts-Gordon LLC at +1.716.852.4400 or 1.800.828.7450, during normal

business hours which are Monday through Friday, 8:15 a.m. to 4:45 p.m., Eastern Time.

For owner safety, a thermostat tag is supplied with the CGTH-Series as a permanent reminder of the importance of maintaining the required safe distances from combustibles. Instructions for installing the tag are located on *Page 36, Section 10.5*. Immediately contact your ROBERTS GORDON® independent distributor or Roberts-Gordon LLC if the tag is missing. See *Page 19, Figure 8* for allowable vent terminal locations.

It is important to keep the minimum required safe distances from combustibles at all times. Clearances from vehicles parked beneath heaters must be maintained. The thermostat tag (included with the heater) must be posted to identify any possible violation of the minimum required safe distances from combustibles from the heater in vehicle areas. Maximum allowable stacking height in storage areas should be identified with signs or appropriate markings. See *Page 16, Figure 6 and Figure 7* for the minimum required safe distances from combustibles.

Due to high temperature, ensure that the heater area is kept clear of furniture, draperies, clothing or other combustible materials. Children and adults should be alerted to the hazards of high surface temperatures and should stay away to avoid burns and clothing ignition. Young children should be carefully supervised when they are in the same room as the heater.

Your heater may be installed in one of three ways: horizontal, 45° tilt left or 45° tilt right. Since the distances for the tilt installation are the same, the chart only shows one (the 45° tilt left). To determine the minimum required safe distances for your heater, you must know the mounting type and model number of your heater.

FIGURE 6: Horizontal Installations

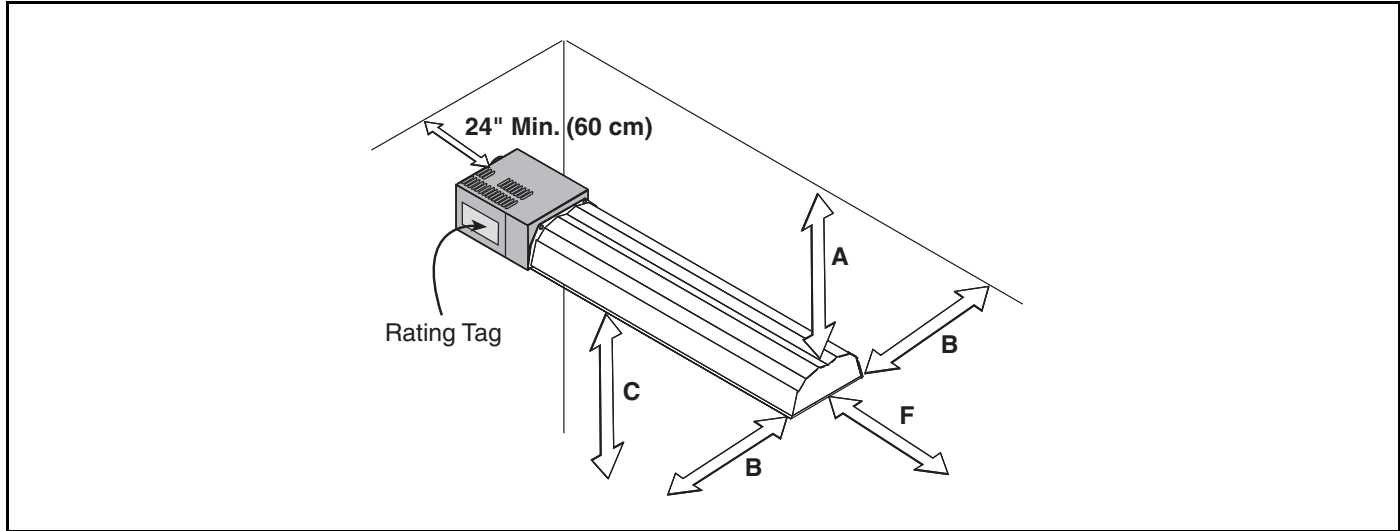
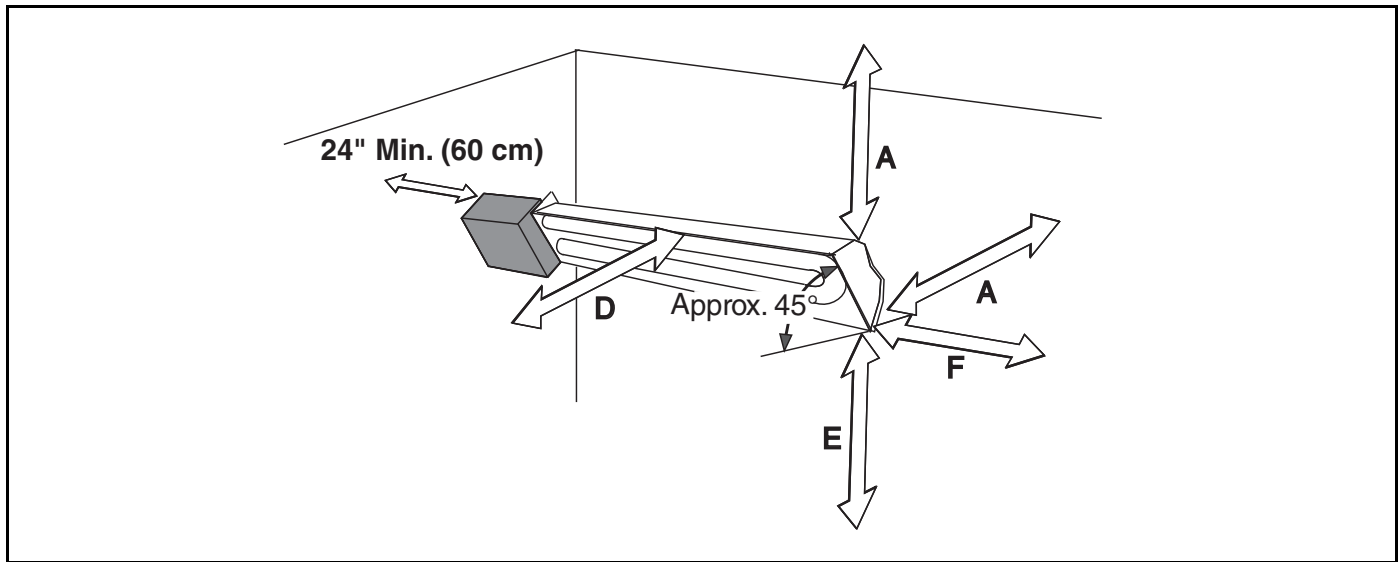

FIGURE 7: 45° Tilted Installations



Required safe distances from combustibles*												
Model	Inches						Metric (cm)					
	A	B	C	D	E	F	A	B	C	D	E	F
CGTH-30	4	16	36	28	34	6	11	41	92	72	87	16
CGTH-40	4	18	48	30	34	6	11	46	122	77	87	16
CGTH-50	4	20	48	32	36	6	11	51	122	82	92	16

*All dimensions are from the reflector.

NOTE: All dimensions indicate the minimum required safe distances from combustibles. Dimensions "C" and "E" DO NOT indicate the required mounting height. The minimum mounting height is 7' (2.1 m), except for aircraft hangars and public garages. See Page 13, Sections 6.5.1 and 6.5.2.

Flue clearances from combustibles are zero. It is not necessary to provide additional clearance on penetrations through the wall or roof.

Know your model number. Model number is found on the rating plate label. See Page 4, Figure 2.

SECTION 8: INSTALLATION**⚠ WARNING****Severe Injury Hazard**

Hang heater with materials with a minimum working load of 75 lbs (33 kg).

Failure to follow these instructions can result in death, injury or property damage.

⚠ WARNING**Cut/Pinch Hazard**

Wear protective gear during installation, operation and service.

Edges are sharp.

Failure to follow these instructions can result in injury.

Several steps are involved in the installation of the heater. Do not attempt to operate the heater until all steps of the installation have been accomplished.

8.1 Safety Equipment

Use of the following safety equipment is recommended for installation of the CGTH-Series heater:

- Work gloves
- Safety glasses

8.2 Installation Tools

Tools required for the installation of the CGTH-Series heater include at a minimum the following:

- Tape measure
- Electric drill (with an assortment of drill bits)
- Pipe wrenches - 2 required
- Screwdriver

- Tin snips
- Hacksaw
- Wire strippers
- Staple gun
- Level
- Pliers
- Crimping tool
- Hole saw - 5" (13 cm)
- Stud Finder (if garage is finished)

8.3 Installation Materials

Materials required for the installation of the CGTH-Series heater include at a minimum the following:

- High temperature silicone sealant (such as General Electric RTV106 or Permatex® Form-A-Gasket® Red)
- Suspension hooks (capable of supporting 75 lbs. each)
- Sheet metal screws

The following items may be required for your particular installation:

- Plastic drain hose
- Additional vent pipe
- Roof flashing
- Rain collar
- Chain - 75 lbs., or equivalent
- Snap hooks (as required)

8.4 Choose Location for Heater

⚠ WARNING

Fire Hazard
Keep all flammable objects, liquids and vapors the minimum required safe distances to combustibles away from heater.
Some objects will catch fire or explode when placed close to heater.
Failure to follow these instructions can result in death, injury or property damage.

When selecting a suitable mounting location for the CGTH-Series heater it is important to consider the following:

- The heater must meet the minimum mounting height requirement of 7' (2.1 m) above the floor. For aircraft hangars and public garages, the heater must meet the minimum mounting height requirement of 8' (2.4 m) above the floor.
- The proposed mounting location allows for the minimum required safe distances from combustibles such as vehicles, wood, gasoline and flammable objects, liquids and vapors.
- The proposed location of the heater will not restrict motion of passageway doors or windows.
- The proposed location will not interfere with operation of the overhead garage door or allow the door to enter the minimum required safe distances from combustibles.
- The proposed location will provide the best coverage of the total area to be heated.
- Consideration be given to the types of vehicles that will be parked in the garage (cars, vans, boats, RV's, etc.).
- The proposed location will allow for the required safe distances from combustibles with respect to the vehicles parked in the garage.

- The proposed location will allow the required utilities (i.e.: gas and electric) and venting to be installed (maximum vent length is 10' (3 m)).
- Sufficient clearances will exist to allow for easy access to the service door.
- Overhead structural members (rafters, beams, etc.) are accessible for attaching the heater.
- To ensure the heater is placed in a approved application.

8.5 General Venting Guidelines

⚠ WARNING

Carbon Monoxide Hazard
Heaters must be exhausted outside.
Use materials supplied.
This heater needs fresh air for safe operation and must be installed so there are provisions for adequate combustion and ventilation air.
Failure to follow these instructions can result in death or injury.

Regardless of the venting arrangement that will be connected to the heater, the following general guidelines for venting must be followed:

1. See *Page 19, Figure 8* for allowable vent terminal locations.
2. The 3" (8 cm) flue pipe must be centered inside the 5" (13 cm) air supply pipe.
3. The total length of vent pipe (horizontal and vertical runs combined, plus the length of the exterior termination) must not exceed 10' (3 m), and must not be less than 2' 6" (76 cm). A maximum of two elbows are allowed with natural gas, one elbow with propane.
4. The vent terminal, mounted outside of the building, should not be located above walkways. Condensate produced during operation of the heater could drip onto the walkway forming ice during cold weather.
5. Be sure that the venting installation is in accordance with all applicable local codes and recommendations of the local gas company.

6. DO NOT connect this heater to a separate chimney and DO NOT common vent with any other fuel burning appliance.

connection with three sheet metal screws.

NOTE: Failure to seal all flue connections 3" (8 cm) will result in erratic heater operation.

IMPORTANT: For standard flue, seal all vent pipe connections with high temperature silicone sealant. Where required, drill holes and secure each

FIGURE 8: Vent Terminal Locations

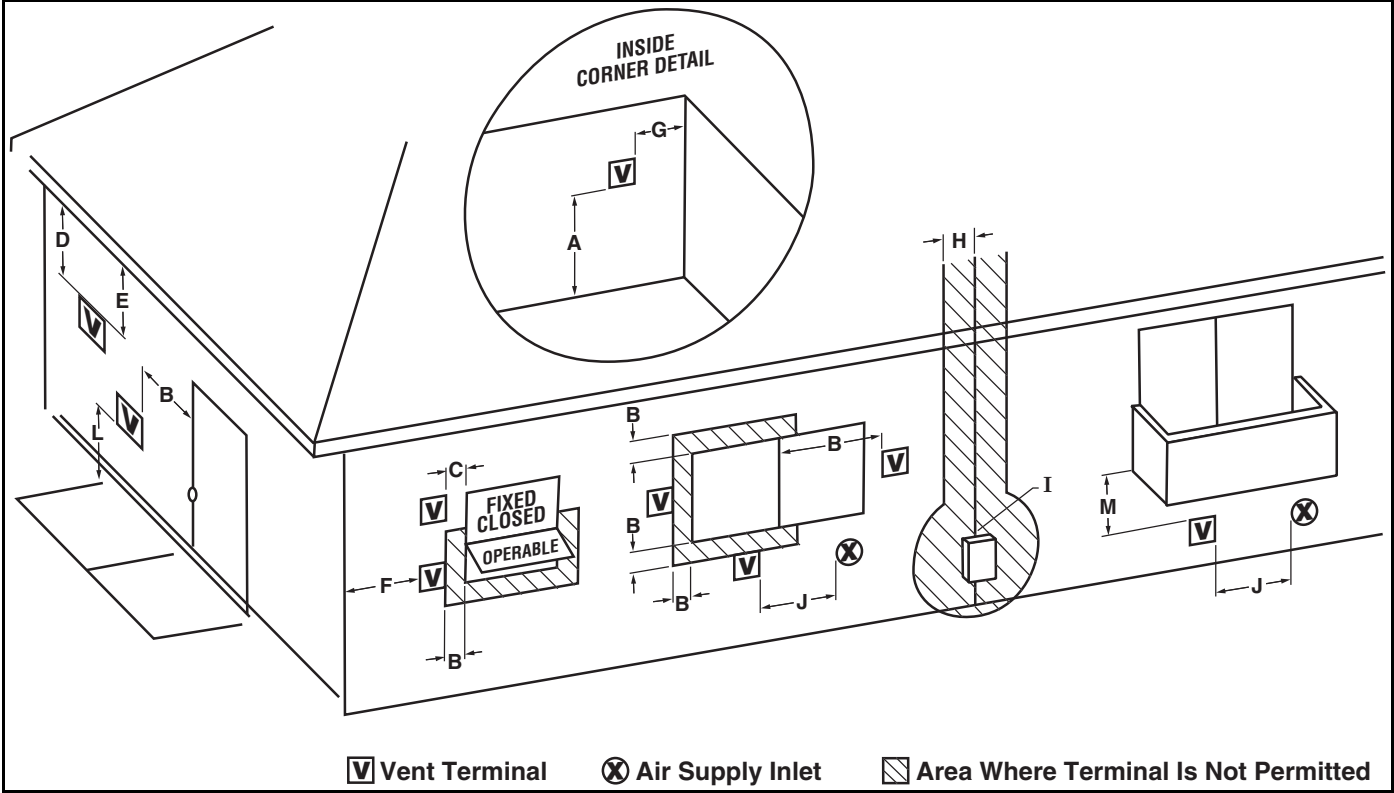

		Canadian Installations ¹	US Installations ²
A	Clearances above grade, veranda, porch, deck, or balcony	12" (30 cm)	12" (30 cm)
B	Clearances to window or door that may be open	12" (30 cm)	9" (23 cm)
C	Clearances to permanently closed window	12" (30 cm)*	12" (30 cm)*
D	Vertical clearances to ventilated soffit located above the terminal within a horizontal distance of 2' (61 cm) from the center line of the terminal.	12" (30 cm)	12" (30 cm)
E	Clearances to unventilated soffit	12" (30 cm)	12" (30 cm)

F	Clearances to outside corner	*	*
G	Clearances to inside corner	18" (46 cm)	18" (46 cm)
H	Clearances to each side of center line extended above meter/regulator assembly	3' (91 cm) within a height 15' (4.5 m) above the meter/regulator assembly	*
I	Clearances to service regulator vent outlet	3' (91 cm)	*
J	Clearances to non mechanical air supply inlet to building or the combustion air inlet to any other appliance	12" (30 cm)	9" (23 cm)
K	Clearances to mechanical air supply inlet	6' (1.83 m)	3' (91 cm) above if within 10' (3 m) horizontally
L	Clearances above paved sidewalks or paved driveway located on private property	7' (2.13 m) ⁺	7' (2.13 m) ⁺
M	Clearances under veranda, porch, deck, or balcony	12" (30 cm)**	12" (30 cm)**

¹ In accordance with the current CSA B149.1, Natural Gas and Propane Installation Code

² In accordance with the current ANSI Z223.1/NFPA 54, National Fuel Gas Code

+ A vent shall not terminate directly above a sidewalk or paved driveway that is located between two single family dwellings and serves both dwellings.

** Permitted only if veranda, porch, deck, or balcony is fully open on a minimum of two sides beneath the floor.

* For clearances not specified in ANSI Z223.1/NFPA 54 or CSA B149.1, clearance shall be in accordance with local installation codes and the requirements of the gas supplier.

8.6 Hang the Heater

⚠ WARNING



Severe Injury Hazard

Hang heater with materials with a minimum working load of 75 lbs (33 kg).

Failure to follow these instructions can result in death, injury or property damage.

⚠ WARNING



Cut/Pinch Hazard

Wear protective gear during installation, operation and service.

Edges are sharp.

Failure to follow these instructions can result in injury.

Residential garages come in a variety of sizes, shapes, styles and methods of construction. Because of all these variables, it is not possible to include mounting hardware with the CGTH-Series heater. Although wooden rafters and joists are the most common overhead structural members in residential garage applications, other structural configurations are also illustrated below.

In the typical suspension methods shown on Page 21, Figure 10, lengths of chain are shown as a means of lowering the heater.

Whichever method of suspension is selected, the three required suspension points must be capable of supporting a minimum of 75 lbs. (33 kg) each.

8.7 Remove Shipping Screw from Control Housing Door

The blower inside the burner box has a shipping

screw installed to protect the blower from damage in shipping. Before hanging or operating heater, remove the shipping screw and paper label from the control housing door, See Page 21, Figure 9. A nylon washer inside the control housing will fall loose. It is not mandatory to remove the washer from the control housing.

FIGURE 9: Shipping Screw

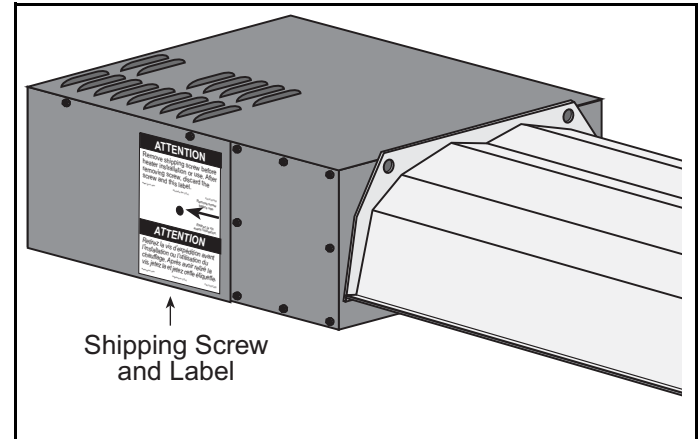
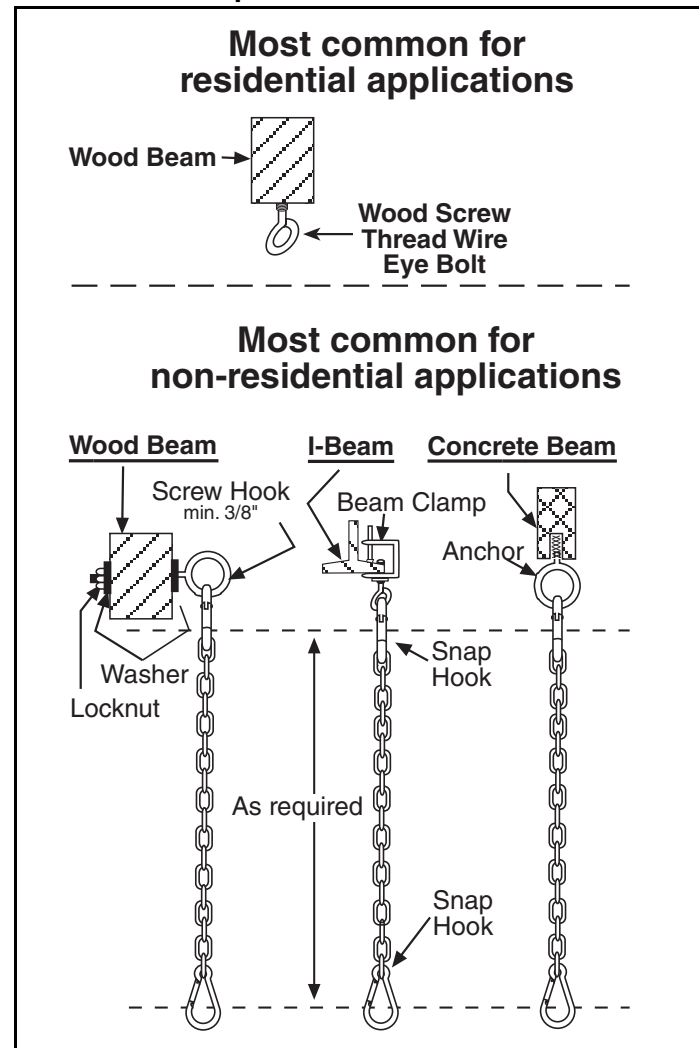

FIGURE 10: Suspension Details



8.8 Heater Assembly

- Slide rear movable hanger onto reflector as shown on *Page 22, Figure 11*.
- Attach reflector end cap with U-Clips as shown on *Page 22, Figure 11*.

FIGURE 11: Heater Assembly

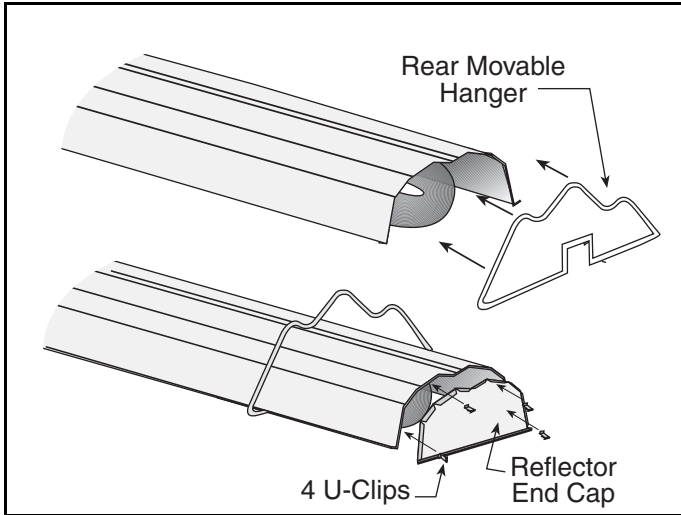

8.9 Typical Installation

Figure 12, on Page 23, shows a typical installation of the CGTH-Series heater. The installation drawing shown has a straight horizontal venting arrangement and specifies the minimum space required for maintenance, as well as the allowable range of distances between the two suspension points. Detailed venting arrangements are illustrated in the venting section of this manual.

FIGURE 12: Typical Installation

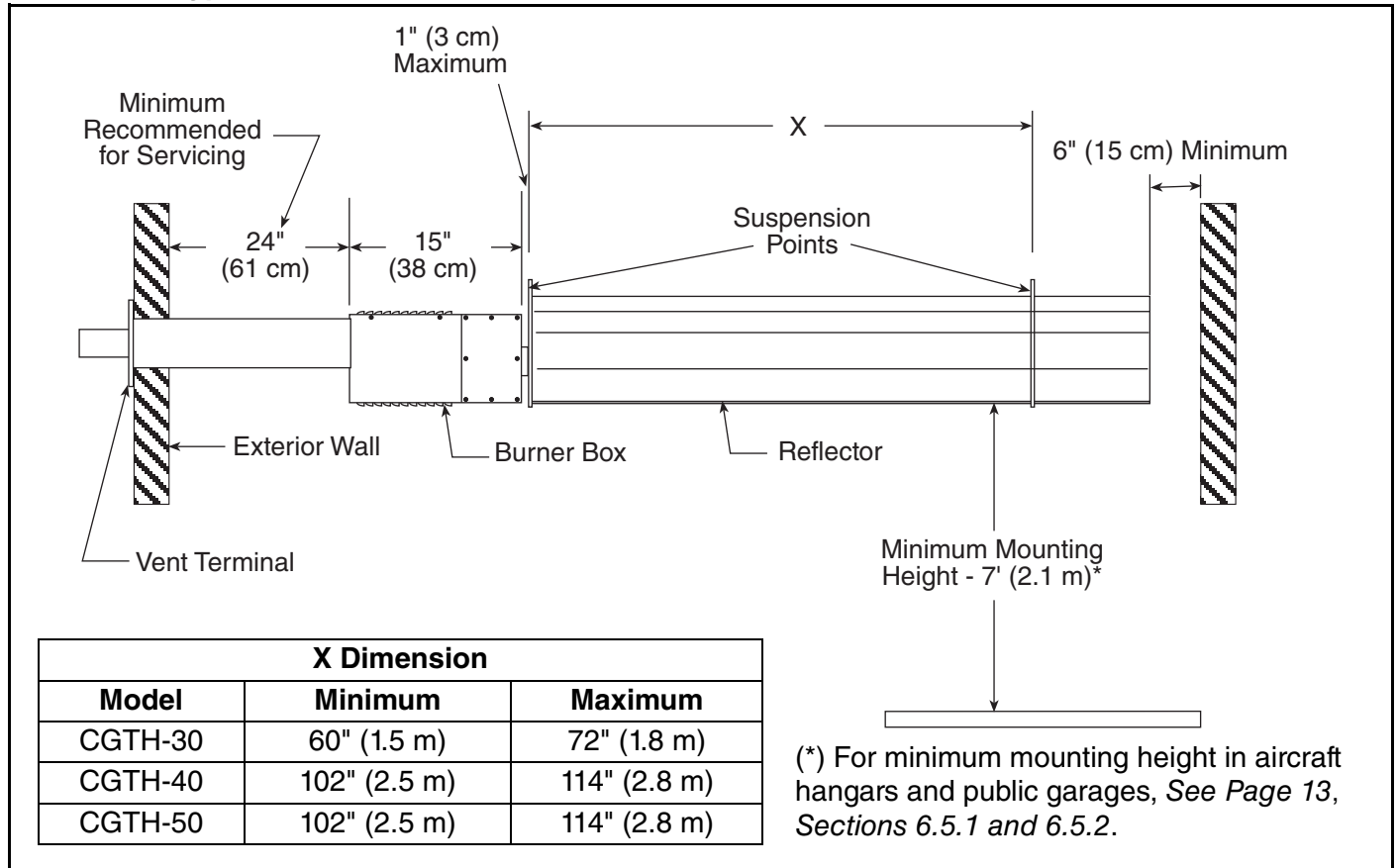

8.10 Heater Orientation

The CGTH-Series heater may be installed in any of the three orientations indicated below. Select the heater orientation that is best suited for the location that you have chosen for your heater.

- Horizontal
- Tilted 45° Right
- Tilted 45° Left

NOTE: If the heater is going to be vented through the roof, be sure to carefully review the roof option installation instructions on Pages 34 and 35. Ensure that the selected mounting site will satisfy the measurement parameters (vent length not to exceed 10' [3 m]) described in that section.

8.11 Horizontal Installation

For Horizontal Installation:

1. See Page 19, Figure 8 for allowable vent terminal locations.

2. Using snap hooks, attach two equal lengths of welded steel chain 75 lbs. (33 kg), to the two uppermost holes in the front fixed hanger.
3. Slip the free end of both chains onto another snap hook. See Page 24, Figure 13.
4. The uppermost snap hook can now be installed on the suspension hardware that you have installed for suspension of the unit. An additional length of chain may also now be installed, if required, to lower the heater.

FIGURE 13: Horizontal Installation

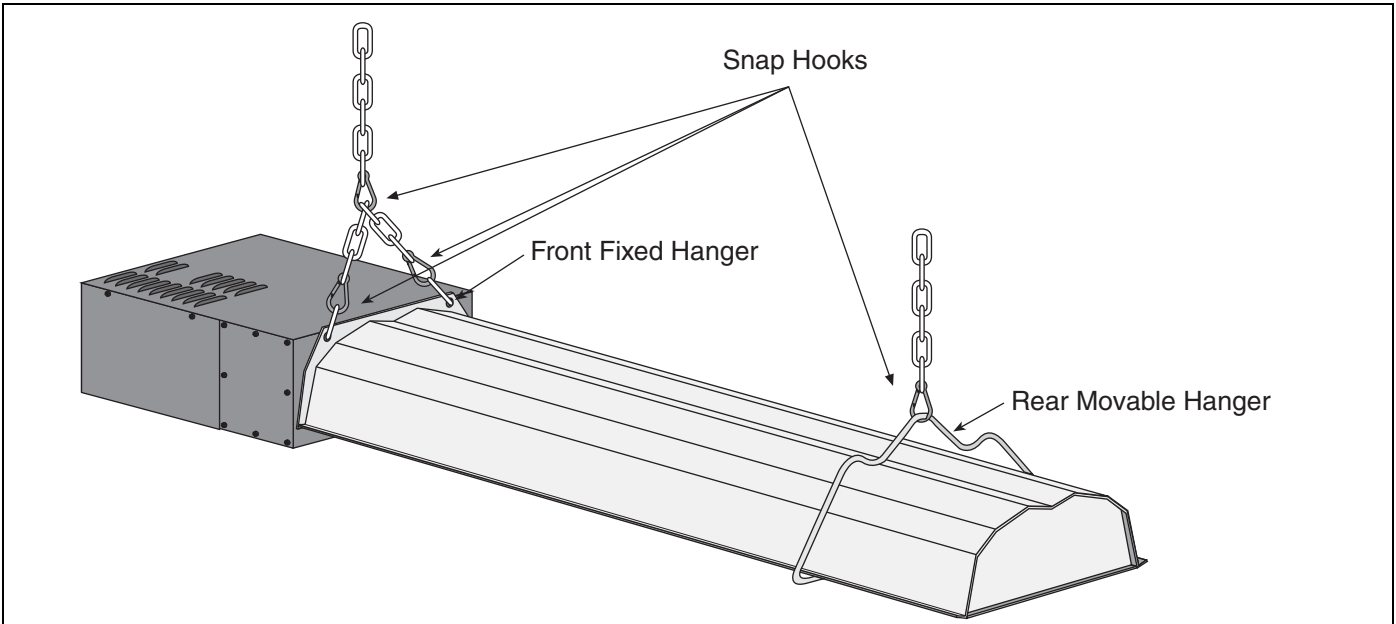

8.12 45° Tilted Installation

For tilted installations:

1. Determine if the heater is going to be tilted left or tilted right. See Page 24, Figure 14. Select the suspension point for left or right tilting. Two suspension points must be used for the front hanger.
2. The uppermost snap hook can now be installed on the suspension hardware that you have installed for suspension of the unit. An additional length of chain may also now be installed, if required, to lower the heater.

FIGURE 14: 45° Tilted Installation

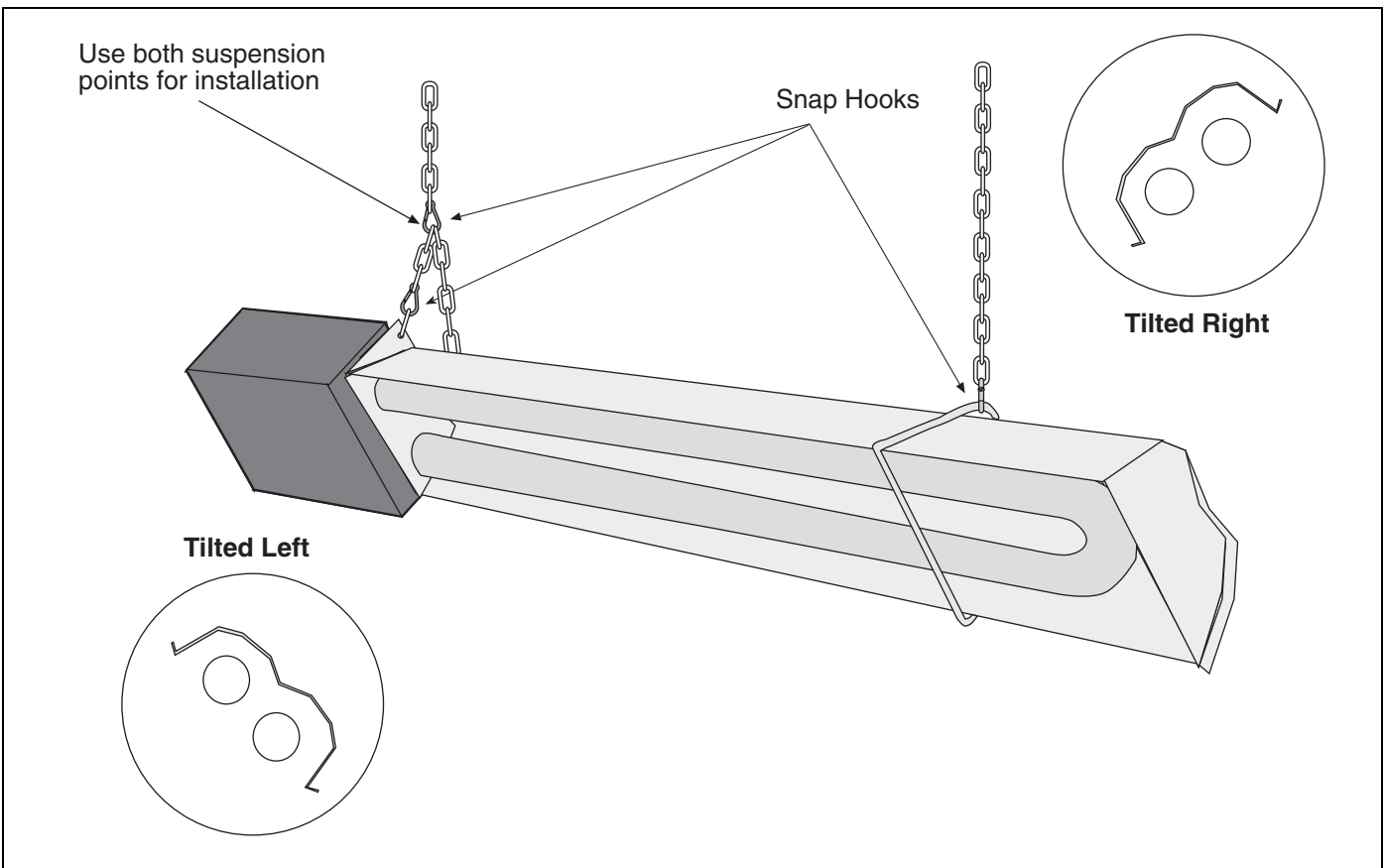

8.13 Grille Installation (for Select Models Only)

A protective grille is included with select models of the CGTH-Series heater. This grille is supplied in sections and must be installed on the underside of the reflector prior to operation.

Grille sections are held in position by a channel formed by the rolled edge of the reflector. The shorter length heater 8' (2.4 m) requires installation of two protective grille sections, while the longer heater 11' 6" (3.5 m) requires three protective grille sections.

Grille Section (P/N 08050001) is open-ended and installed along the length of the reflector. Grille End Cap (P/N 08050002) is the formed end cap and is installed at the end of the grille that is furthest from the burner.

Installation:

Step 1. Silicone Cap Installation. See Page 25, Figure 15.

- Silicone caps (P/N 91915951) are to be placed along each side of the grille at both end fingers and the center finger.

FIGURE 15: Silicone Cap Installation

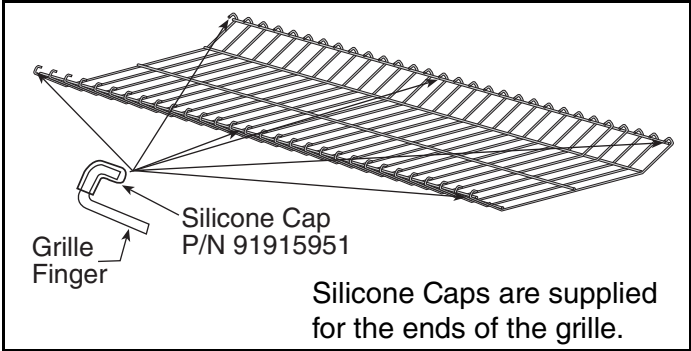

Step 2. Attach grille end cap to final grille section. See Page 25, Figure 16.

Step 3. Install grille sections as follows on Page 26, Figure 17.

- Attach first grille section(s) (P/N 08050001) to underside of reflector as shown. The wires of the grille will rest in the channel formed by the rolled edges of the reflector. Be certain the silicone caps have been installed.
- Attach final grille section with end cap to under side of reflector. Butt grille toward the front fixed hanger that is adjacent to the burner and to each other as shown.

FIGURE 16: Grille End Cap Installation

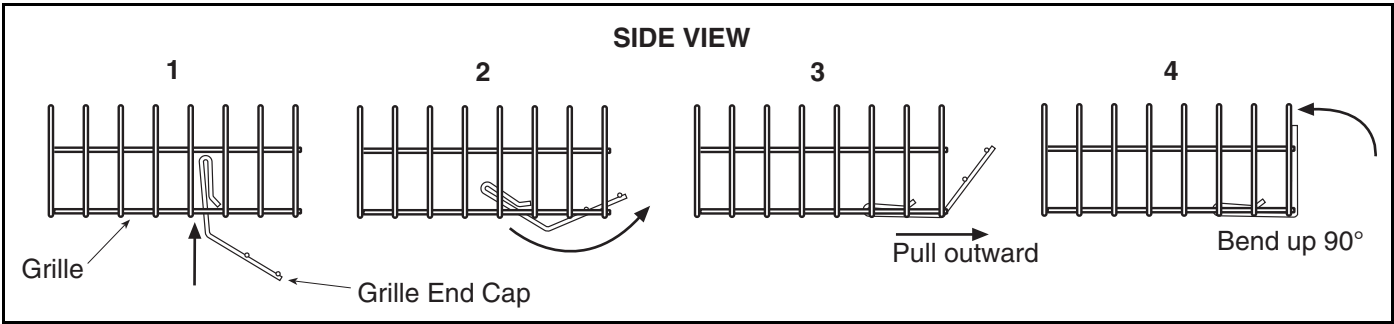
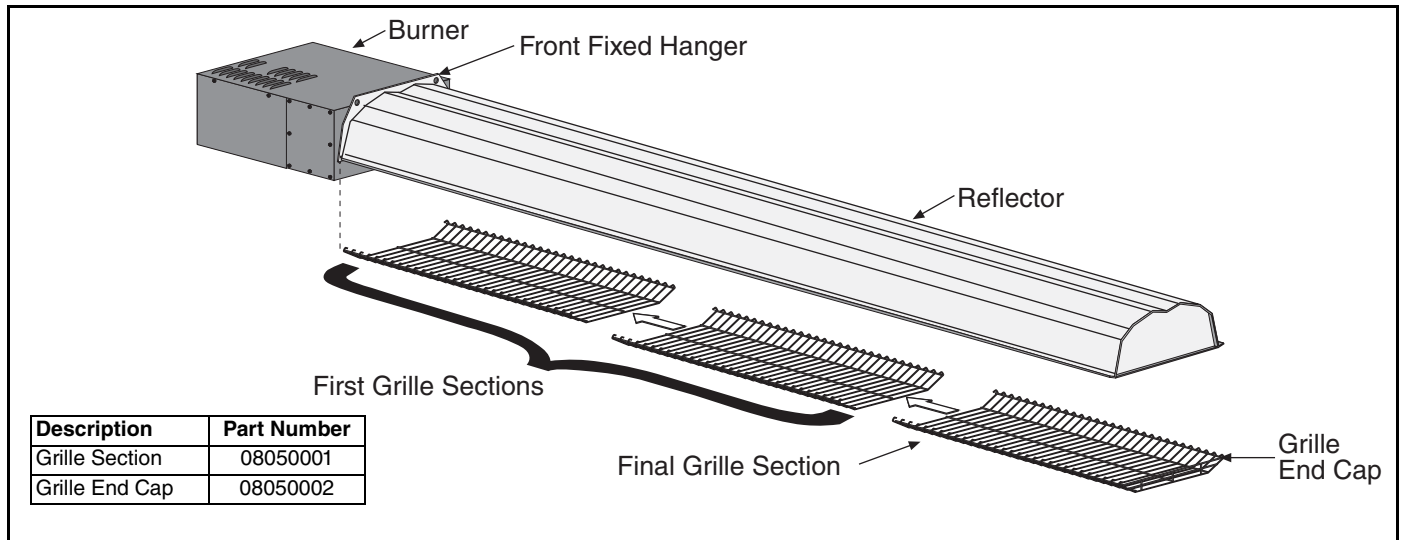

FIGURE 17: Reflector and Grille



SECTION 9: VENTING INSTALLATION

! WARNING**Carbon Monoxide Hazard**

Heaters must be exhausted outside.

Use materials supplied.

This heater needs fresh air for safe operation and must be installed so there are provisions for adequate combustion and ventilation air.

Failure to follow these instructions can result in death or injury.

! WARNING**Cut/Pinch Hazard**

Wear protective gear during installation, operation and service.

Edges are sharp.

Failure to follow these instructions can result in injury.

Venting is available in galvanized vent material and Cox Geelan vent material. For the galvanized vent material, *See Pages 28 through 32*. For the Cox Geelan vent material, *See Pages 32 through 34*. The galvanized vent material is available for horizontal installation only. The Cox Geelan vent style can be installed horizontally or vertically. The maximum overall vent length is 10' (3 m) with only one 90° elbow. The flue must be self supporting.

9.1 General Venting Requirements

See Page 19, Figure 8 for allowable vent terminal locations. This heater must be vented in accordance with the following national codes and any local codes which may apply:

United States: Refer to National Fuel Gas Code NFPA 54/ANSI Z223.1 - latest revision.

Canada: Refer to Natural Gas and Propane Installation Code CSA B149.1 - latest revision.

Vent terminal must be installed at a height sufficient to prevent blockage by snow and protect building materials from degradation by flue gases.

Vent must exit a building not less than 7' (2.1 m) above grade when located adjacent to public walkways.

For galvanized venting, seal all joints with high temperature silicone sealant.

To avoid frost and condensation forming in the balanced flue, set thermostat to 50°F (10° C) and above if outside air temperature falls below -20° F (-28° C).

9.1.1 United States Requirements

Vent must terminate at least 3' (.9 m) above any forced air inlet located within 10' (3 m).

Vent must terminate at least 4' (1.3 m) below, 4' (1.3 m) horizontally from, or 1' (.3 m) above any door, window, or gravity inlet into any building.

Vent terminal shall be located at least 1' (.9 m) from any opening through which vent gases could enter a building.

9.1.2 Canadian Requirements

Vent terminal must not be installed less than 3' (.9 m) from any building opening.

Vent terminal must be installed at least 3' (.9 m) above grade.

9.2 Install Galvanized Collar

For all galvanized flue installations, the galvanized collar is shipped loose in the carton. See Page 28, Figure 18. For ease of installation, the vent collar should be installed on the rear surface of the burner before the heater is suspended. Install the galvanized collar as follows:

1. Apply a bead of high temperature silicone sealant to the mating surface of the galvanized collar mounting flange.
2. Align the three mounting holes of the galvanized collar with the three galvanized collar mounting holes on the rear surface of the burner.
3. Using a #2 phillips head screwdriver, or 1/4" nut driver, secure the galvanized collar to the rear surface of the burner with the three screws (#8 x 3/8" long) provided in the accessories bag supplied with the heater.

FIGURE 18: Rear View

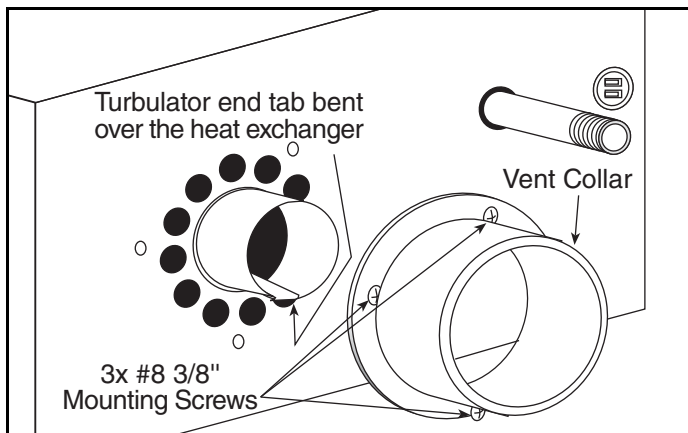

9.3 Galvanized Horizontal Venting

⚠ WARNING
Carbon Monoxide Hazard
Heaters must be exhausted outside.
Use materials supplied.
This heater needs fresh air for safe operation and must be installed so there are provisions for adequate combustion and ventilation air.
Failure to follow these instructions can result in death or injury.

After the heater has been properly suspended in accordance with the preceding headings of this section, proceed to install the venting as described below. See Page 29, Figure 19.

1. Using a tape measure, measure the distance from the floor to the center of the vent collar on the rear surface of the burner. Note this dimension here _____.
2. Using the tape measure, transfer this measurement to the inside surface of the exterior wall that the vent will penetrate; make a reference mark. Check the location of the hole to ensure that there are no internal wall structures (i.e. studs) to prevent penetration. Also check that the outlet of the vent does not compromise the general venting requirements, See Page 27, Section 9.1.
3. Using the tape measure, measure the distance between the rear surface of the heater and the exterior wall. Note this dimension here _____.

NOTE: If the distance between the rear surface of heater and the exterior wall is greater than 5' (1.5 m), a 5' (1.5 m) balanced flue vent extension kit (P/N 08039000) will be required.

4. From the reference mark made in step 2, measure down vertically 1/4" (.6 cm) per foot measured in step 3. Cut 5" (13 cm) vent terminal clearance hole at the lower reference.
 5. Install 3" (8 cm) flue pipe from the vent collar, on the rear surface of the burner, and through the exterior wall. Be sure to seal any joints in the 3" (8 cm) flue pipe with high temperature silicone sealant and secure them with three sheet metal screws.
- IMPORTANT:** The 3" (8 cm) flue pipe must extend a minimum of 6" (15 cm) beyond the exterior surface of wall/fresh air intake.
6. Assemble or cut the 5" (13 cm) air supply pipe to run between the vent collar on the rear surface of the burner and the outside surface of the exterior wall. Be sure to seal any joints in the 5" (13 cm) air supply pipe with high temperature silicone sealant and secure them with three sheet metal screws.
 7. From the exterior of the building, slip the assembled or cut 5" (13 cm) air supply pipe over the installed 3" (8 cm) flue pipe. Connect the 5" (13 cm) pipe to the vent collar on the rear sur-

face of the burner with high temperature silicone sealant and secure the connection with three sheet metal screws.

- From the exterior of the building, slip the vent terminal onto the 3" (8 cm) flue pipe and guide the sleeve portion of the vent terminal over the 5" (13 cm) air supply pipe that is flush with exterior surface of wall. Secure air vent pipe to the vent terminal collar with silicone sealant.

- Secure the vent terminal to the exterior surface of the wall.

NOTE: If the protruding 3" (8 cm) flue pipe is directly below and within 24" (60 cm) of the building soffit, the optional vent extension should be used to prevent flue gasses from degrading building surfaces.

FIGURE 19: Horizontal Installation Side View

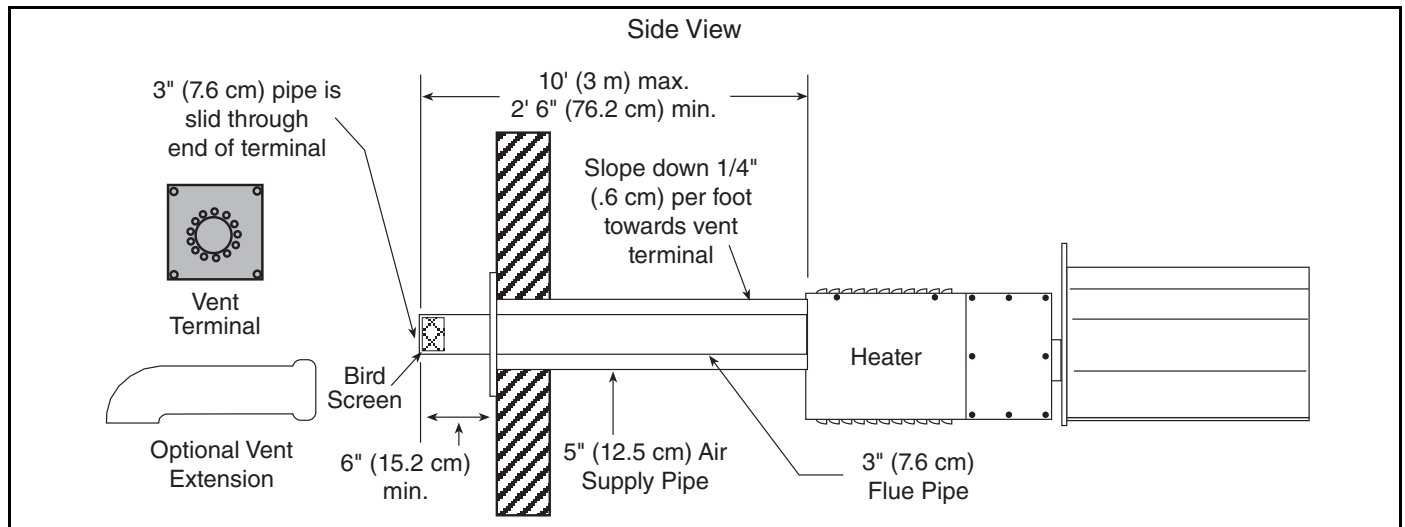

9.3.1 Bird Screen Installation

The bird screen supplied with the heater must always be installed with the galvanized vent option. The screen is to be installed directly in the end of the 3" (8 cm) flue pipe or in the vent terminal extension available as an option. Both screen installations are described below.

Installing bird screen in 3" (8 cm) flue pipe:

- Insert the bird screen into the inside diameter of the 3" (8 cm) flue pipe as shown on Page 29, Figure 20.
- Secure the bird screen in position with a sheet metal screw.

Installing bird screen in optional vent terminal extension:

- Insert the bird screen into the inside diameter of the vent terminal extension as shown on Page 29, Figure 20.
- Using the handle from a hammer, or other similar device, push the bird screen into the vent extension as far as possible.
- Orient the vent extension as shown on Page 29, Figure 20. Slip the extension onto 3" (8 cm) flue pipe as far as possible; secure the vent exten-

sion to the flue pipe with three sheet metal screws.

FIGURE 20: Bird Screen Installation

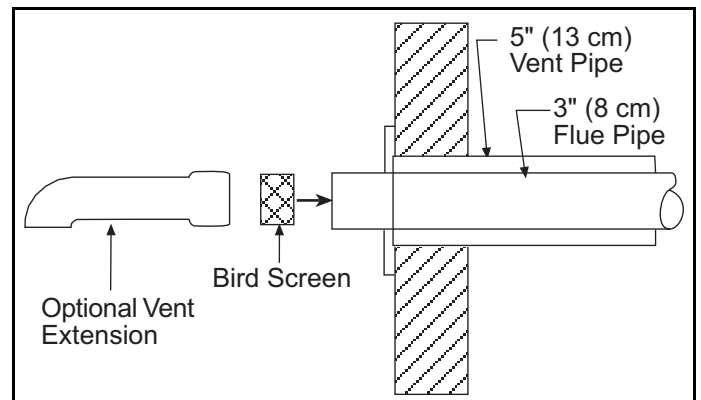

9.3.2 Galvanized Horizontal Venting with an Elbow

FIGURE 21: Horizontal Installation Top View

⚠ WARNING



Carbon Monoxide Hazard

Heaters must be exhausted outside.

Use materials supplied.

This heater needs fresh air for safe operation and must be installed so there are provisions for adequate combustion and ventilation air.

Failure to follow these instructions can result in death or injury.

After the heater has been properly suspended in accordance with the preceding headings of this section, proceed to install the venting as described below:

NOTE: The 90° elbow kit (P/N 08038000) will be required for this installation.

1. Using a tape measure, measure the distance from the floor to the center of the vent collar on the rear surface of the burner. Note this dimension here _____.
2. Using the tape measure, transfer this measurement to the inside surface of the exterior wall that the vent will penetrate; make a reference mark. Check the location of the hole to ensure that there are no internal wall structures (i.e. studs) to prevent penetration. Also check that the outlet of the vent does not compromise the general venting requirements, See Page 27, Section 9.1.
3. Using a tape measure, measure distances 'A', 'B', 'C' and 'D' as shown in Figure 21. Note these dimensions here (A= _____, B= _____, C= _____, D= _____) and add them together.

NOTE: If the total of dimensions above are greater than 5' (1.5 m), a 5' (1.5 m) balanced flue vent extension kit (P/N 08039000) will be required.

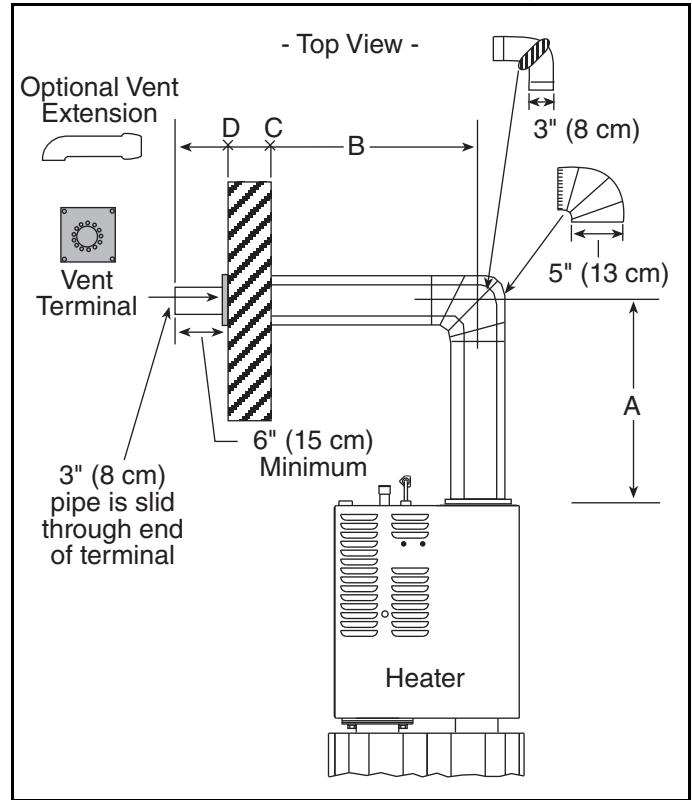

4. From the reference mark made in step 2, measure down vertically 1/4" (.6 cm) per foot measured in step 3. Cut 5" (13 cm) vent terminal clearance hole at the lower reference.
5. Cut the 3" (8 cm) vent to length as follows:
 Length A
 3" diameter = A – 8"
 Length B
 3" diameter = B + C + D – 7 3/4"

Always cut a non-swaged end.

6. Wrap the 1" (2.5 cm) diameter spring around the outside diameter of the 3" (8 cm) elbow as shown on Page 31, Figure 22.

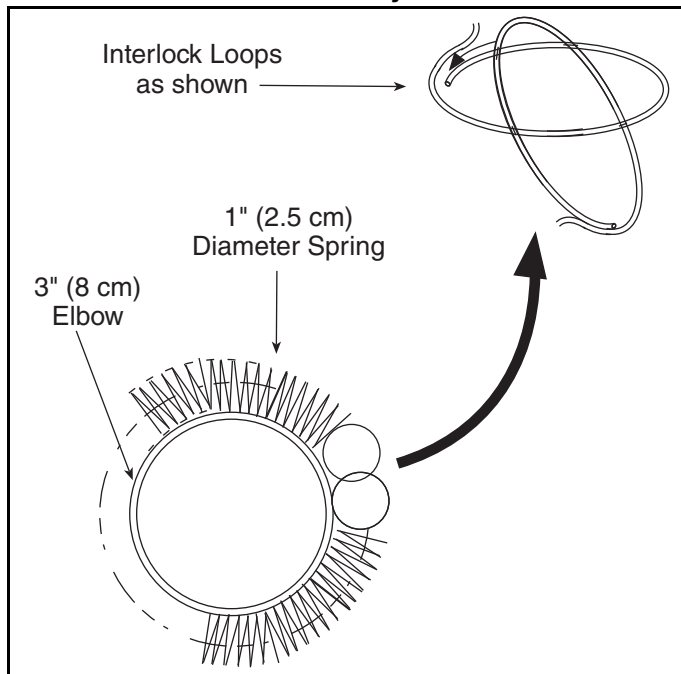
FIGURE 22: Elbow Assembly End View

7. Interlock the loops at each end of the spring coils together as shown on Page 31, Figure 22. The loops will lock together to produce a continuous coil spring spacer around the outside diameter of the 3" (8 cm) elbow.
8. Fit the 5" (13 cm) elbow over the 3" (8 cm) elbow (See Page 31, Figure 23).

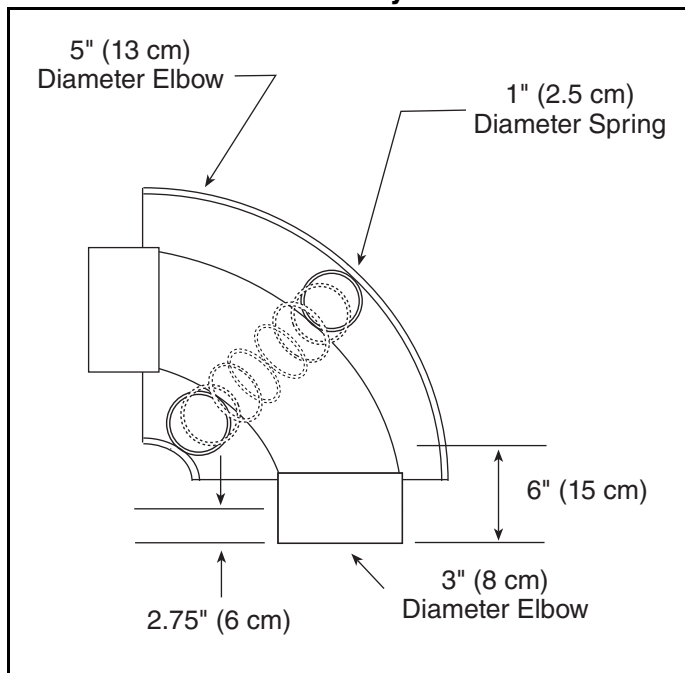
FIGURE 23: Elbow Assembly Cross Section View

9. Attach 3" (8 cm) elbow portion of 90° elbow kit to the 3" (8 cm) flue pipe (length 'A'). **Use high temperature silicone sealant and 3 sheet metal screws.** (See Page 31, Figure 24)

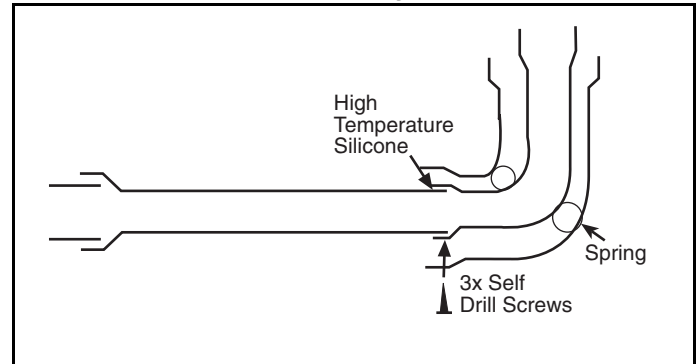
FIGURE 24: Elbow Assembly

10. Completely assemble the 3" (8 cm) vent lengths A, B and elbow and attach to the heater. Put the vent collar on the 3" (8 cm) vent. All joints must be sealed with high temperature sealant and sheet metal screws. (See Page 31, Figure 25)

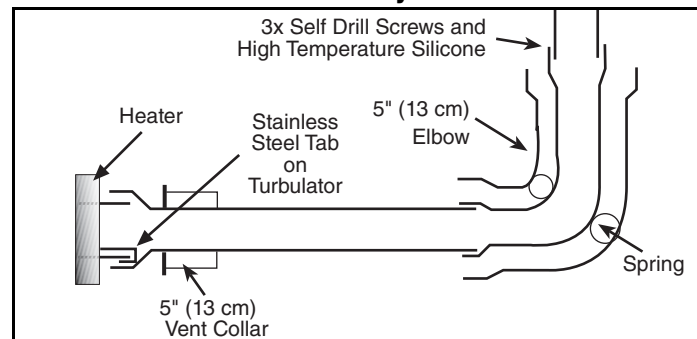
FIGURE 25: Elbow Assembly for Vent Collar

11. Attach the vent collar to the heater. Hold the 5" (13 cm) vent material up to the 3" (8 cm) vent and mark the required length. Note the length must be sufficient for a minimum of 1 1/2" (4 cm) overlap at both ends. Cut the vent to length from the non crimped end. Wrap the 3" (8 cm) tube with the 5" (13 cm) vent and snap the vent together. Attach the 5" (13 cm) vent at both ends. All joints must be sealed with high temperature sealant and sheet metal screws. (See Page 32, Figure 26)

FIGURE 26: Vent Collar and 5" Vent Attachment

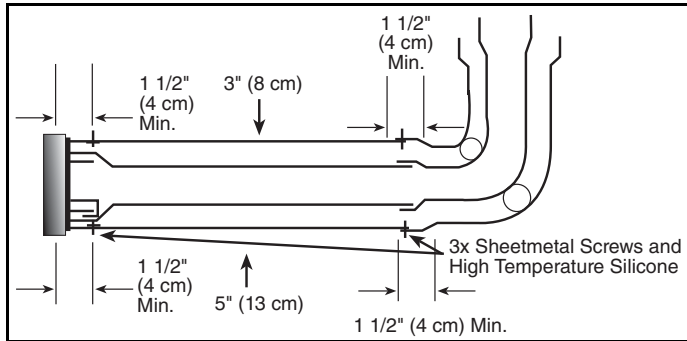

12. Insert vent terminal and repeat step 11 for 5" (13 cm) from the elbow through the wall. Secure the vent terminal to the exterior surface of the wall.

NOTE: If the protruding 3" (8 cm) flue pipe is directly below and within 24" (61 cm) of the building soffit, the optional vent extension should be used and secured with three sheet metal screws.

9.4 Cox Geelen Horizontal Venting

⚠ WARNING

Carbon Monoxide Hazard

Heaters must be exhausted outside.

Use materials supplied.

This heater needs fresh air for safe operation and must be installed so there are provisions for adequate combustion and ventilation air.

Failure to follow these instructions can result in death or injury.

After the heater has been properly suspended in accordance with the preceding headings of this section, proceed to install the venting as described below:

1. Using a tape measure, measure the distance from the floor to the center of the vent collar on the rear surface of the burner. Note this dimension here _____.
2. Using the tape measure, transfer this measurement to the inside surface of the exterior wall that the vent will penetrate; make a reference mark. Check the location of the hole to ensure

that there are no internal wall structures (i.e. stud) to prevent penetration. Also check that the outlet of the vent does not compromise the general venting requirements, See Page 27, Section 9.1. Cut 5" (13 cm) vent terminal clearance hole as required.

3. Using the tape measure, measure the distance between the rear surface of the heater and the exterior wall. Note this dimension here _____.

A. The following combinations will result in dimension B from Figure 27:

Horizontal Wall Vent Kit (P/N 08032200) = 25" (64 cm)

Horizontal Wall Vent Kit (P/N 08032200) + Concentric Flue 10" (25 cm) (P/N 90506003) = 35" (89 cm)

Horizontal Wall Vent Kit (P/N 08032200) + Concentric Flue 20" (50 cm) (P/N 90506004) = 45" (114 cm)

Horizontal Wall Vent Kit (P/N 08032200) + Concentric Flue 39" (100 cm) (P/N 90506005) = 64" (163 cm)

Select the appropriate combination for the distance required. If a shorter distance is required, see Page 33, Step 5 for cutting instructions.

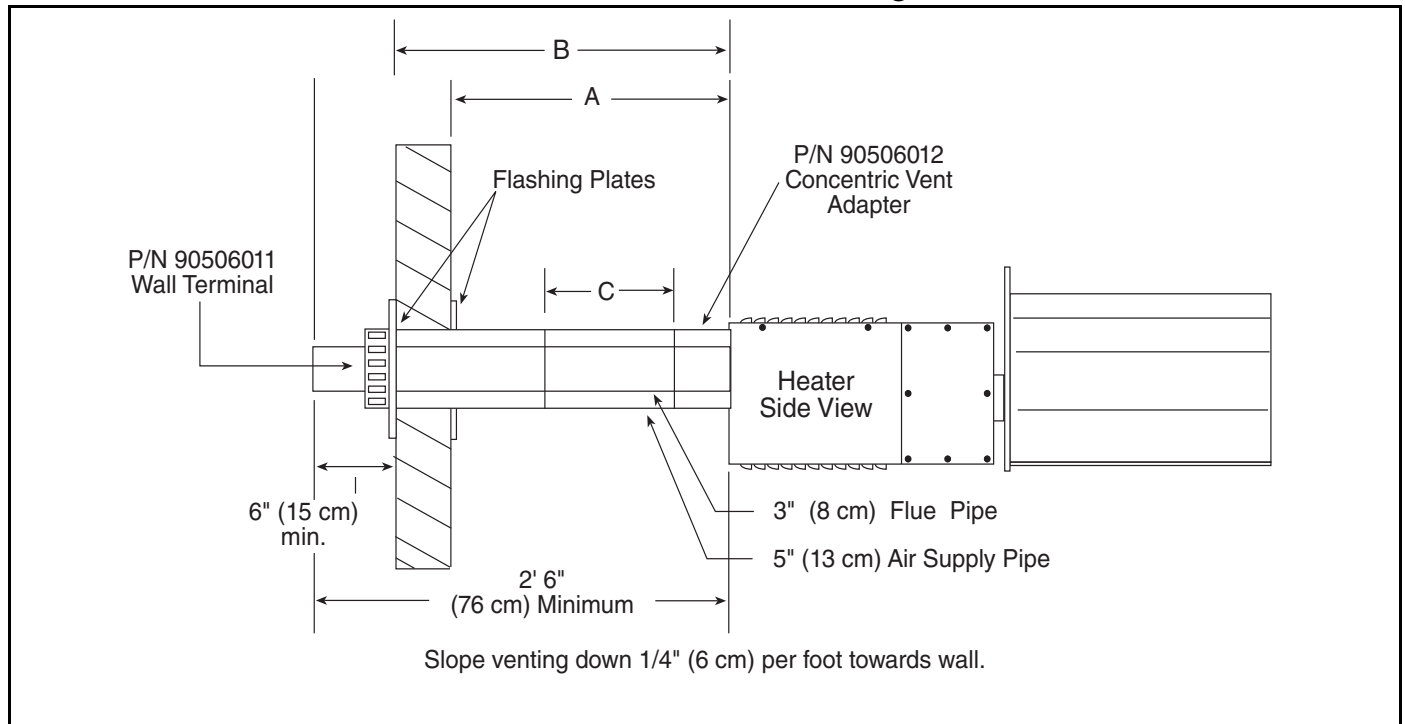
FIGURE 27: Horizontal Installation Side View Cox Geelen Venting

4. Install the vent adapter (P/N 90506012) and secure with #8 x 3/8" sheet metal screws as shown on Page 33, Figure 28.
5. If the concentric vent has to be cut (see note on Page 34), follow instructions A-E. See Page 33, Figure 29. If the concentric vent does not have to be cut, see note on Page 34. Follow instructions A & F below. See Page 33, Figure 29.
 - A. Install the horizontal vent terminal (P/N 90506011) ensure that the air holes intake hole are facing down. Install the flashing plates with the hardware supplied. See Figure 29.

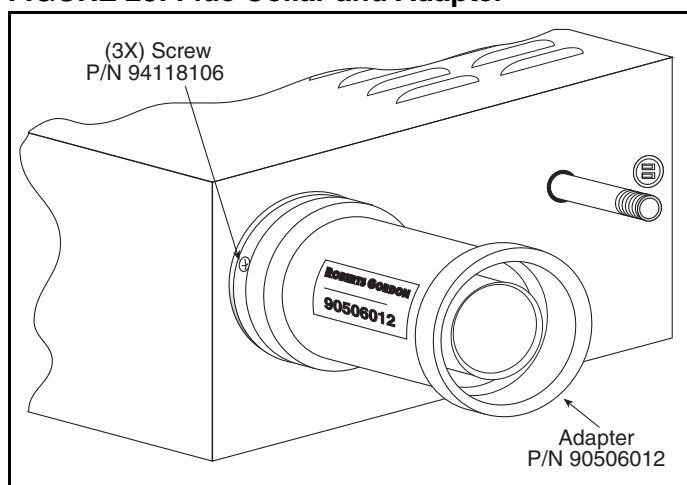
FIGURE 28: Flue Collar and Adapter

B. Measure from the end of the adapter to the

end of the vent terminal, dimension C, Page 33, Figure 27. Note the dimension here,

- C. Separate the 3" (8 cm) and the 5" (13 cm) vent by pulling the 3" (8 cm) vent out from the end with the internal silicone gasket. Remove the internal spring from the non-silicone gasket end of the 5" (13 cm) vent.
- D. Add 3.5" (9 cm) to the dimension noted in step B, this is to allow for the internal joint of the vent. Cut both the 3" (8 cm) and 5" (13 cm) vent to this length and de-burr the ends. Always cut from the non-silicone gasket end.
- E. Re-assemble the 3" (8 cm) and 5" (13 cm) vent with the internal spacer at the silicone gasket end only.

FIGURE 29: Horizontal Venting Configurations

Table 1: Components

Part Number	Description
90506003	Concentric Flue 10" (25 cm)
90506004	Concentric Flue 20" (51 cm)
90506005	Concentric Flue 39" (99 cm)
90506006	Concentric Flue 79" (200 cm)
90506011	Storm Collar 27.5" (70 cm)
90506012	Burner/Vent Adapter
90506013	Wall Plate

F. Push vent terminal away from heater. Insert the cut vent in between the adapter and the vent terminal. Starting at the adapter end, push the plain end of the vent into the silicone gaskets. The connection will fit firmly together. If undue force is required to assemble the parts, first check the cut length for burrs, second apply warm soapy water to the silicone gaskets.

Note: The gasket construction of this venting is designed to make a permanent airtight connection, additional silicone sealant and securing screws are not to be used.

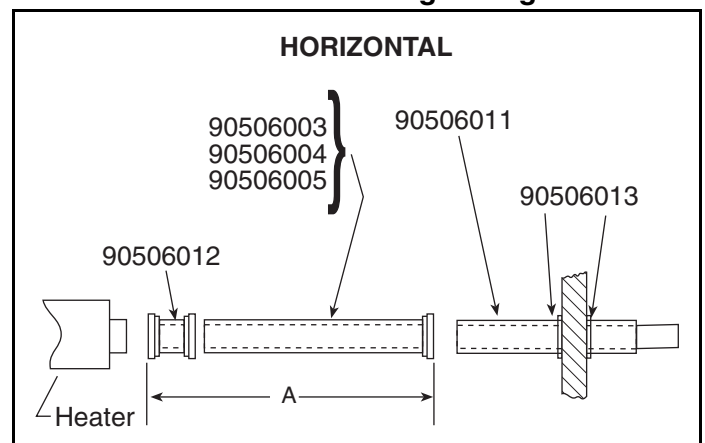
FIGURE 30: Vertical Venting Configurations

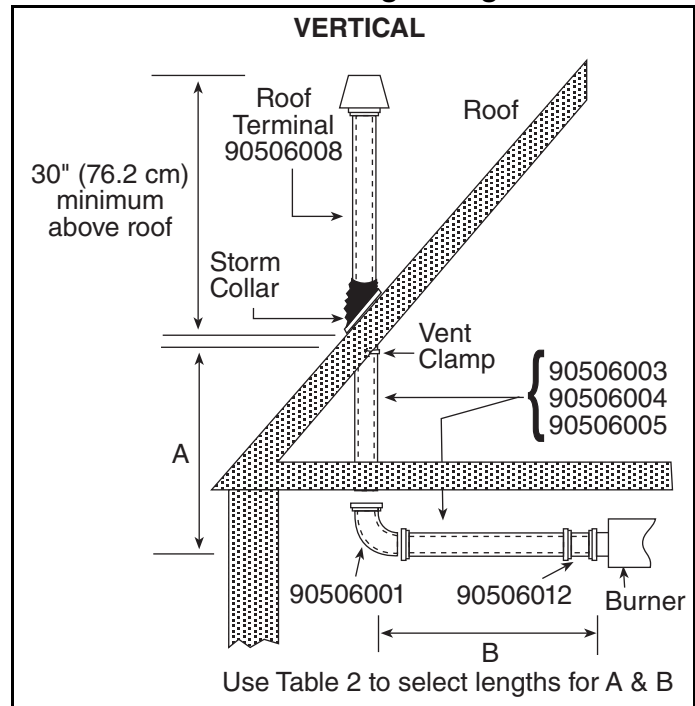

Table 2: Components

Part Number	Description
90506001	Elbow 90°
90506003	Concentric Flue 10" (25 cm)
90506004	Concentric Flue 20" (50 cm)
90506005	Concentric Flue 39" (100 cm)
90506006	Concentric Flue 79" (200 cm)
90506008	Roof Terminal 50.5" (128 cm)
90506012	Burner/Vent Adapter

- Using a saw, cut an appropriate size clearance hole in the roof to accommodate the vertical run of vent pipe and the vent termination (minimum 5" (13 cm)).
- Install the vent adapter (P/N 90506012) and secure with #8 x 3/8" sheet metal screws as shown on Page 33, Figure 28.
- Measure the distance to the center of the hole from the vent adapter. Note this dimension here _____. If the concentric vent has to be cut, use the following guidelines:
 - Subtract 1.5" (3.8 cm) to allow for the elbow and both joints.
 - Separate the 3" (8 cm) and the 5" (13 cm) vent by pulling the 3" (8 cm) vent out from the end with the internal silicone gasket. Remove the internal spring from the non-silicone gasket end of the 5" (13 cm) vent.

9.5 Cox Geelen Vertical Venting

! WARNING

Carbon Monoxide Hazard

Heaters must be exhausted outside.

Use materials supplied.

This heater needs fresh air for safe operation and must be installed so there are provisions for adequate combustion and ventilation air.

Failure to follow these instructions can result in death or injury.

After the heater has been properly suspended in accordance with the preceding headings of this section, proceed to install the venting as described below. Be sure to observe the General Venting Guidelines on Page 18, Section 8.5.

- C. Always cut the 3" (8 cm) and 5" (13 cm) vent separately to avoid damage.
 - D. Always cut from the non-silicone gasket end and de burr thoroughly.
4. Install a 4-7" EPDM storm collar (P/N 90506015) following the instruction below:
- A. Slide storm collar down over lower section of the vertical vent. Water can be used as a lubricant. Apply silicone sealant on underside of flange. Turning back flexible flange makes this simple.
 - B. Press pipe flashing into contours of roof panel configuration. If there is a sharp angle in the panel, a blunt tool can be used to press the flashing into place.
 - C. Lower roof terminal (P/N 90506008) through the 5" (13 cm) hole. From the inside ensure the vent is square. Secure the vent clamp to the inside of the roof. See *Figure 30*.
 - D. Apply silicone sealant between base and roof. Drill and fasten flashing to surface. Use a blunt tool to press base into sharp corners of valleys while drilling; and against to insert rivet or screw.
 - E. Follow the sequence: drill two holes on opposite sides of aluminum base through sheet. Fit fasteners progressively outwards in pairs avoiding gaps over 1.5" (4 cm).
5. With the vent collar on the burner, install the additional vent pipe. Push the plain end of the vent into the silicone gaskets. The connection will fit firmly together. If undue force is required to assemble the parts, first, check the cut length for burrs, second, apply warm soapy water to the silicone gaskets.

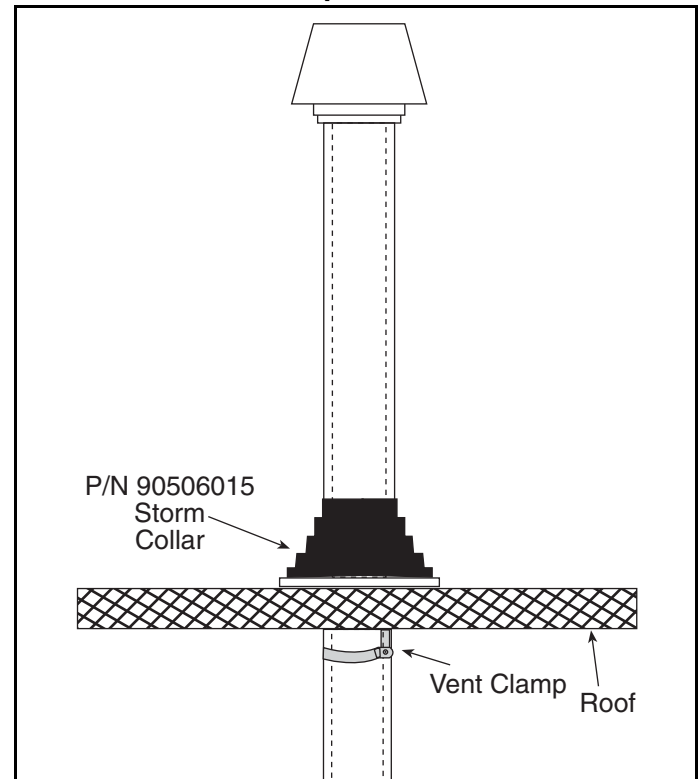
FIGURE 31: Vent Clamp

SECTION 10: ELECTRICAL SERVICE INSTALLATION

⚠ DANGER

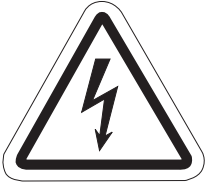
Electrical Shock Hazard
Plug heater into grounded three-prong ceiling receptacle.
Do not cut or remove the grounding prong from this plug.
Do not use with an extension cord.
Failure to follow these instructions can result in death or electrical shock.

⚠ DANGER

Electrical Shock Hazard
Disconnect electric before service.
Replace door before operating.
Heater must be properly grounded.
Failure to follow these instructions can result in death or electrical shock.

10.1 System Requirements

The CGTH-Series heater requires a grounded three-prong electrical outlet to be installed within 18" (46 cm) of the rear surface of the heater's burner. It is recommended that the outlet for the heater be ceiling-mounted and should be on a dedicated circuit. DO NOT use an electrical extension cord to operate the heater.

Heater Rating: 120V, 60 Hz, 1 Ø, 1A

10.2 Grounding

The heater must be electrically grounded in accordance with the following codes: **United States:** refer to National Electrical Code® NFPA 70 - latest revision
Canada: refer to Canadian Electrical Code, CSA C22.1 Part I - latest revision.

10.3 Important Notes

1. The CGTH-Series heater is controlled by a low voltage (24 V AC) thermostat supplied with the heater. The control transformer located inside the burner supplies the necessary electrical power to operate the thermostat. No other electrical power to the thermostat is required.
2. The wire for connecting the thermostat to the heater is not supplied. Refer to the installation instructions supplied with the thermostat for correct wire sizing.

10.4 Thermostat Placement

For best results, locate the thermostat as follows:

- Mount the thermostat on an interior wall whenever possible.
- Mount the thermostat approximately 60" (15.2 cm) from the floor.
- Mount the thermostat so that it is shielded from the heat that is radiated from the heater.
- Mount the thermostat over the thermostat tag that is provided in the accessories bag. The thermostat tag contains important safety information and **must** be used.

10.5 Thermostat Installation

1. Connect thermostat wiring to the thermostat as follows:
 - A. Attach one wire of the thermostat wires to the "R" terminal on the inside of the thermostat; attach the remaining wire to the "W" terminal. *See Page 37, Figure 32.*
 - B. Peel off backing of adhesive strips on the rear surface of the thermostat tag and position the tag against the wall; secure thermostat over tag using two screws.

FIGURE 32: Thermostat Installation

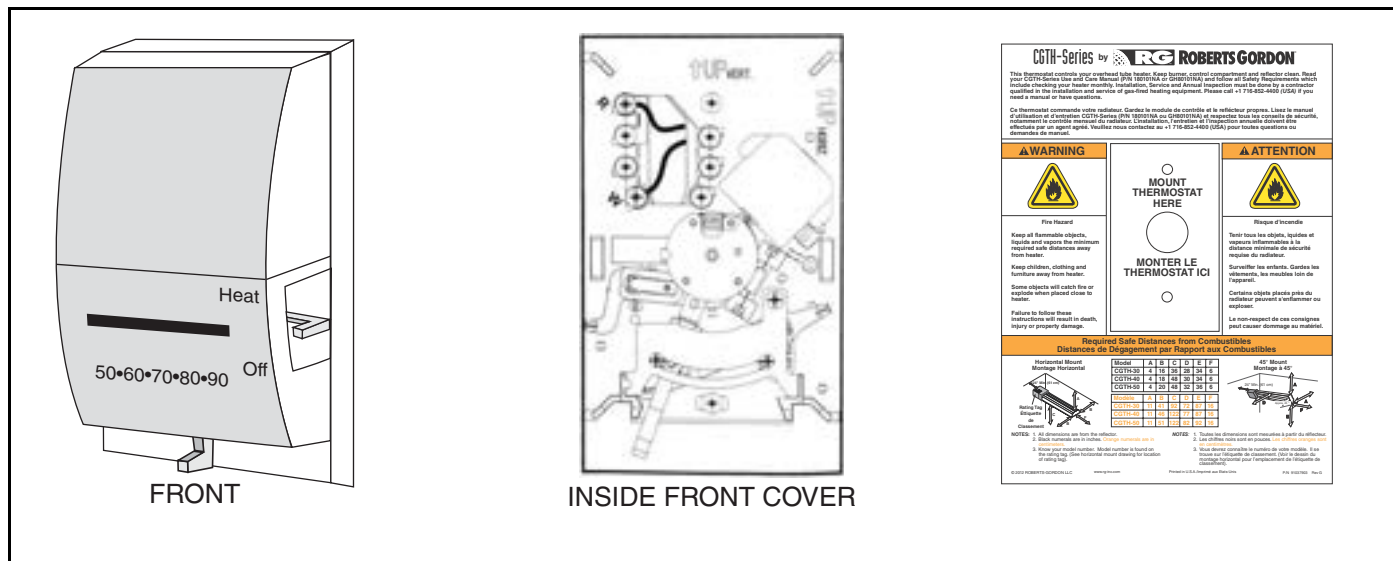

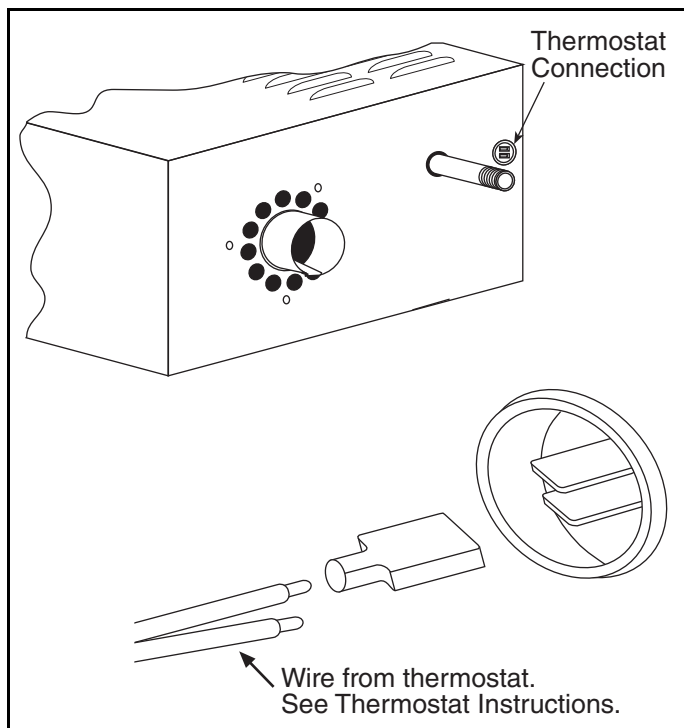

2. Route thermostat wiring between the thermostat and the rear of the heater. Carefully staple the wires so as not to damage them and to produce a professional appearing installation.
3. See Page 37, Figure 33. Connect thermostat wires to the "THERMOSTAT CONNECTION" on the rear surface of the burner as follows:
 - A. Using an appropriate crimping tool, install the female terminals (included in accessories bag) on the two wires from the thermostat.
 - B. Push the female terminals on the male terminals. The thermostat terminals are not polarity sensitive.

FIGURE 33: Thermostat Installation Rear View



10.6 Connection Diagram

⚠ DANGER

Electrical Shock Hazard
Disconnect electric before service.
Heater must be properly grounded.
Failure to follow these instructions can result in death or electrical shock.

⚠ DANGER

Electrical Shock Hazard
Plug heater into grounded three-prong ceiling receptacle.
Do not cut or remove the grounding prong from this plug.
Do not use with an extension cord.
Failure to follow these instructions can result in death or electrical shock.

⚠ WARNING

Fire Hazard
Label all wires prior to disconnection when servicing controls. Wiring errors can cause improper and dangerous operation.
Verify proper operation after servicing.
Failure to follow these instructions can result in death, injury or property damage.

If any of the original wire as supplied with the heater must be replaced, it must be replaced with wiring material having a temperature rating of at least 105°C and 600 volts.

FIGURE 34: Internal Wiring Diagram

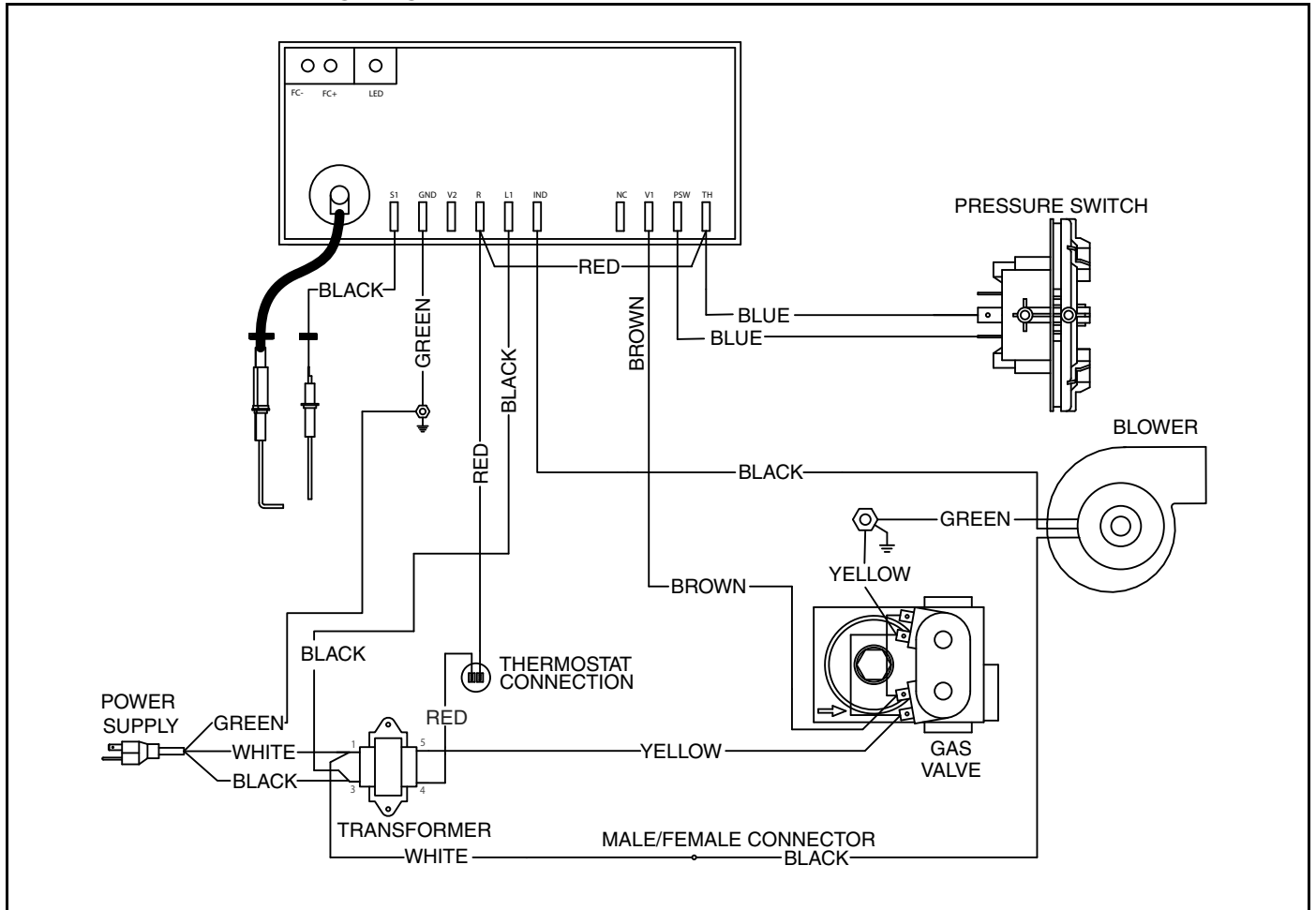
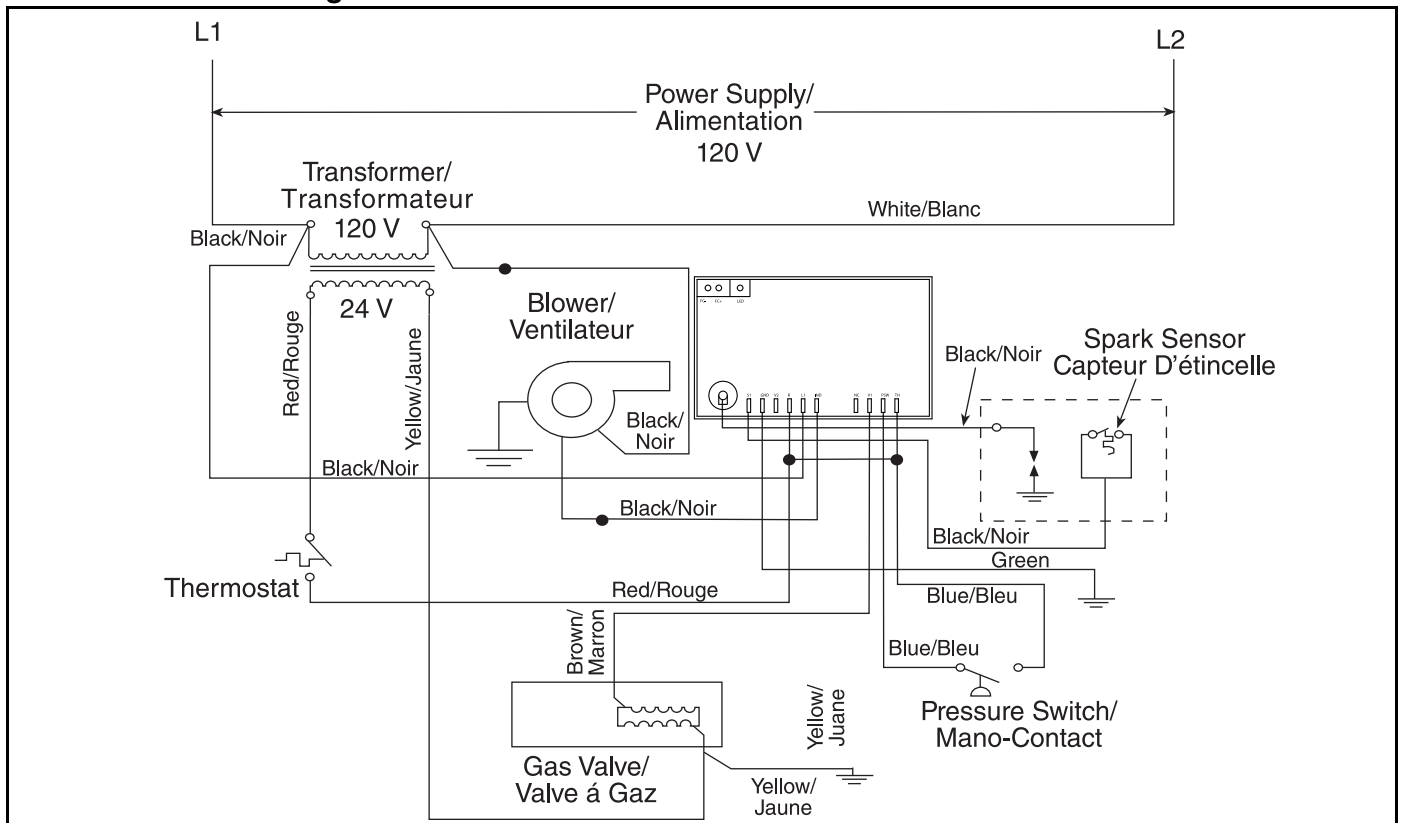



FIGURE 35: Ladder Diagram



SECTION 11: GAS SERVICE INSTALLATION

⚠ WARNING



Explosion Hazard

Tighten gas hose fittings to connect gas supply according to Figure 36.

Leak test all components of gas piping before operation.

Gas can leak if piping is not installed properly.

Do not high pressure test gas piping with heater connected.

Failure to follow these instructions can result in death, injury or property damage.

Before connecting the heater to the supply system, on Page 40, Figure 36, verify that all high pressure testing of the gas piping has been completed. Do not high pressure test (greater than 1/2" psi/3.5 kPa) the gas piping with the burner connected. The appliance must be isolated from the gas piping system by closing manual gas shut-off valve during any pressure testing at pressures less than or equal to 1/2" psi (3.5 kPa).

Follow these instructions to ensure a safe gas supply system installation:

1. Support all gas piping with suitable pipe hanging materials.
2. Use wrought iron or wrought steel pipe and malleable iron fittings. The use of copper tube and brass fittings is acceptable when such use is in compliance with local codes. All pipe, tube and fittings should be new and free from defects. Carefully ream the pipe and tube ends to remove obstructions and burrs.
3. Use LP gas resistant joint compound on all threads.
4. Check the pipe and tube connections for leaks before placing heating equipment into service. When checking for gas leaks, use a soap and water solution; **never use an open flame.**



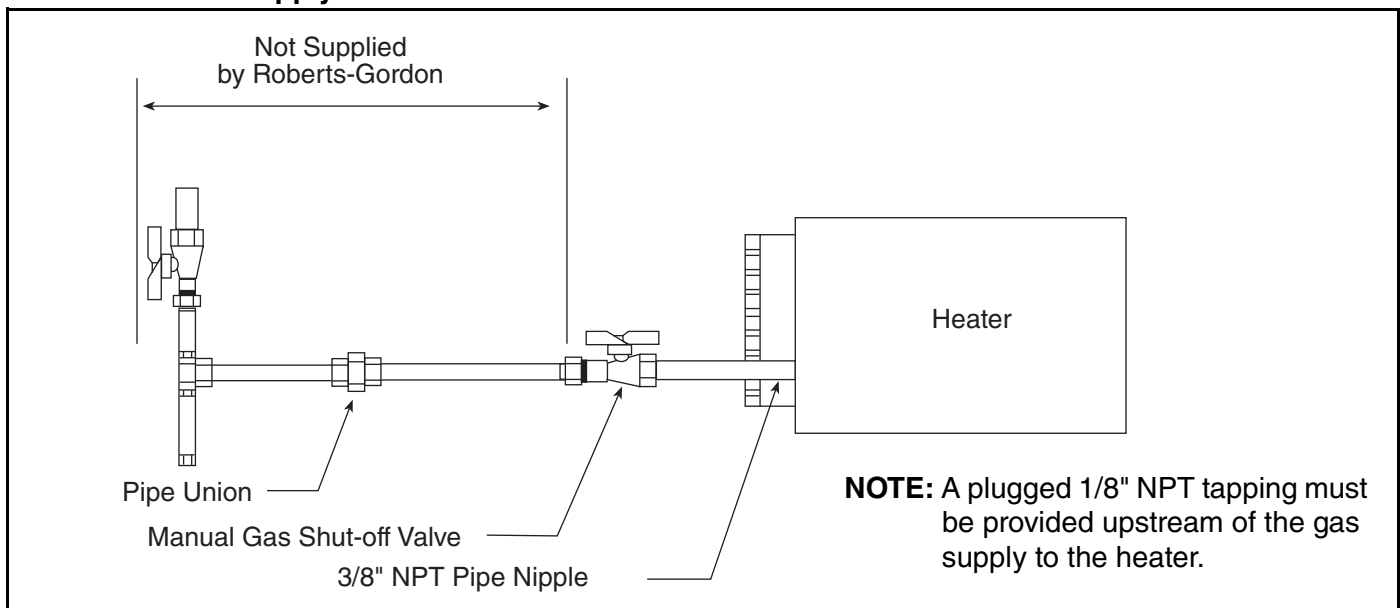

11.1 Install Gas Supply Lines

A 3/8" gas supply connection is required as shown on Page 40, Figure 36. To check system pressure, a plugged 1/8" NPT tapping is required upstream of the manual gas shut-off valve supplied with the heater.

FIGURE 36: Gas Supply Lines



SECTION 12: OPERATION

⚠ DANGER		⚠ WARNING	
			
<p>Electrical Shock Hazard</p> <p>Disconnect electric before service.</p> <p>Replace door before operating.</p> <p>Heater must be connected to a properly grounded electrical source.</p>	<p>Explosion Hazard</p> <p>Turn off gas supply to heater before service.</p>	<p>Burn Hazard</p> <p>Allow heater to cool before service.</p> <p>Tubing may still be hot after operation.</p>	<p>Cut/Pinch Hazard</p> <p>Wear protective gear during installation, operation and service.</p> <p>Edges are sharp.</p>
<p>Failure to follow these instructions can result in death, electric shock, injury or property damage.</p>			

1. This appliance does not have a pilot. It is equipped with an ignition device which automatically lights the burner. DO NOT try to light the burner by hand.
2. BEFORE OPERATING, smell all around the appliance area for gas. Be sure to smell next to the floor because some gas is heavier than air and will settle on the floor.
3. Use only your hand to push in or turn the gas control knob. Never use tools. If the knob will not push in or turn by hand, don't try to repair it, call a qualified service technician. Force or attempted repair may result in a fire or explosion.
4. DO NOT use this appliance if any part has been under water. Immediately call a qualified service technician to inspect the appliance and replace any part of the control system and any gas control which has been under water.

12.1 Operating Instructions

STOP! Read the safety information above.

1. Set the thermostat to the lowest setting.
2. Turn off all electric power to the heater.
3. Do not try to light the burner by hand.

4. Turn off the manual gas valve in the heater supply line.

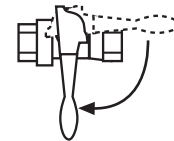

5. Wait five (5) minutes to clear out any gas. If you then smell gas, STOP! If you do not smell gas, go to the next step.
6. Open the manual gas valve in the heater supply line.
7. Turn on electric power to the heater.
8. Set the thermostat to the desired setting.
9. If the heater will not operate, See Page 41, Section 12.2 and call your service technician or gas supplier.



12.2 To Turn Off Gas To Heater

1. Set the thermostat to the lowest setting.
2. Turn off all electric power to the heater if service is to be performed.
3. Turn off the manual gas valve in the heater supply line.

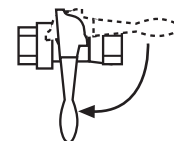

12.3 Sequence of Operation

1. When the thermostat calls for heat, the blower motor will energize.

2. When the motor approaches nominal running speed, the pressure switch closes and activates the ignition module which in turn initiates the purge.
3. The ignition module then energizes the spark igniter.
4. When sparking begins, the gas valve is energized.
5. If a flame is detected, the gas valve remains open. When the call for heat is satisfied, the system control mechanism de-energizes and the gas valve is turned off.
6. If no flame is detected, the gas valve is closed, and a purge period begins. After the purge period, the ignition module energizes the spark igniter and the gas valve. If a flame is still not established, a third and final purge/ignition sequence is begun. After three failed attempts, the system control mechanism will lock out for a period of one hour or until the unit is reset.
7. Reset is accomplished by removing power from the heater for at least five seconds.
8. With a three-try module, when the flame is established and then lost on the first or second trial, the gas valve will automatically turn off. A purge and trial for ignition will then occur.

12.4 Testing

Establish that a satisfactorily purged gas supply and an electrical supply is available to the heater.

With the gas supply turned off at the gas valve, and the electrical supply isolated by switching off at the local switch and removing the appliance electrical plug, open the control chamber secured by the four screws. Remove the sealing screw from the outlet pressure tap with a 3/16" Hex Key Allen Wrench and install a test tap and hose. Remove the cover cap from the regulator screw with a straight slot screwdriver through the top hole of the burner. See Page 42, Figure 37.

Turn on appliance gas valve and connect appliance electrical plug. Ensure that the timer or thermostat, if fitted, is set to call for heat. Switch on power at the local switch. If necessary, the sequence as described above, in the first and second paragraphs, should take place. If not, refer to detailed fault finding sequence. When flame is established, check the gas pressure reading and adjust if necessary. See data label or Page 10, Section 2, for required gas pressure setting.

Check the gas pressure at the outlet of the gas valve to ensure minimum pressure. See Page 10, Section 4, for required gas pressure settings.

Switch off the electrical supply (shutting down the heater), remove pressure gauge and refit plug at outlet pressure tap, ensuring a tight gas seal. Replace cap and regulator screw. Close burner side cover.

FIGURE 37: Pressure Testing

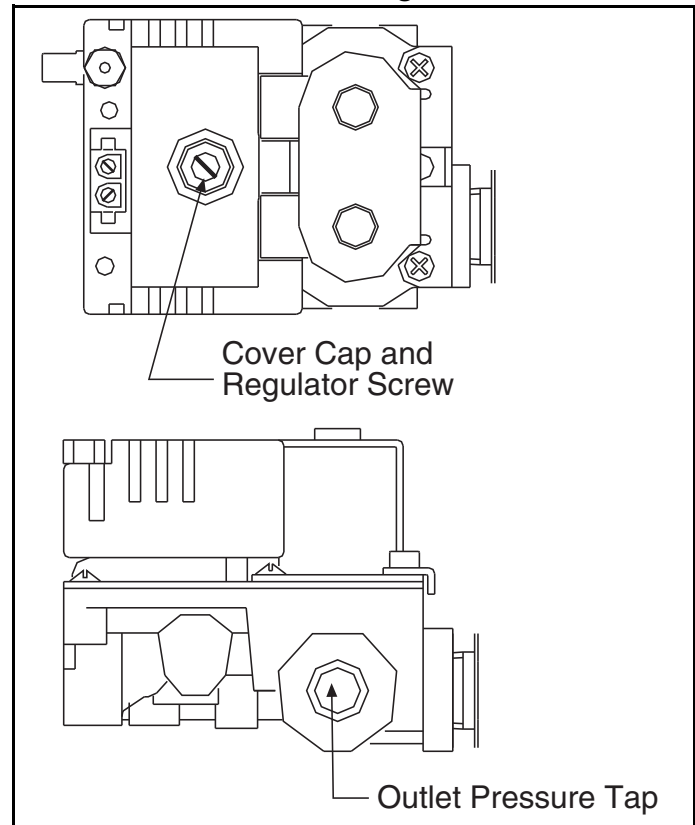

SECTION 13: TROUBLESHOOTING

⚠ DANGER**Electrical Shock Hazard**

Disconnect electric before service.

Replace door before operating.

Heater must be properly grounded.

Failure to follow these instructions can result in death or electrical shock.

⚠ WARNING**Fire Hazard**

Keep all flammable objects, liquids and vapors the minimum required safe distances to combustibles away from heater.

Some objects will catch fire or explode when placed close to heater.

**Explosion Hazard**

Turn off gas supply to heater before service.

**Burn Hazard**

Allow heater to cool before service.

Tubing may still be hot after operation.

**Cut/Pinch Hazard**

Wear protective gear during installation, operation and service.

Edges are sharp.

Failure to follow these instructions can result in death, injury or property damage.

13.1 General

This troubleshooting guide has been designed to assist you in locating and correcting minor problems that may occur with the CGTH-Series heater.

Installation Code and Annual Inspections:

All installation and service of ROBERTS GORDON® equipment must be performed by a contractor qualified in the installation and service of equipment sold and supplied by Roberts-Gordon LLC and conform to all requirements set forth in the ROBERTS GORDON® manuals and all applicable governmental authorities pertaining to the installation, service, operation and labeling of the equipment. To help facilitate optimum performance and safety, Roberts-Gordon LLC recommends that a qualified contractor conduct, at a minimum, annual inspections of your ROBERTS GORDON® equipment and perform service where necessary, using only replacement parts sold and supplied by Roberts-Gordon LLC.

BLOWER DOES NOT COME ON

Possible Cause	Try this....
Power cord is not plugged in.	Plug power cord into a grounded three prong outlet.
Thermostat setting is too low.	Increase thermostat temperature setting.
DSI module needs to be reset.	Unplug heater power cord from the electrical outlet; wait for a minimum of five seconds. Plug heater cord back into outlet.
No power at electrical outlet.	Replace fuse or reset circuit breaker.
Faulty thermostat wiring or faulty thermostat.	Install jumper wire across THERMOSTAT CONNECTION wires on the rear of the burner. If blower starts, remove jumper wire and proceed as follows: Check wiring between thermostat and heater. If wiring is OK, then, replace thermostat.

IGNITER DOES NOT SPARK

Possible Cause	Try this....
DSI module needs to be reset.	Unplug heater power cord from the electrical outlet; wait for a minimum of five seconds. Plug heater cord back into outlet.
Faulty igniter or ignition wire.	Unplug heater power cord from the electrical outlet; check igniter and ignition wire for damage. If damaged, replace igniter and/or ignition cable.
Blocked Vent/Air Supply the	The heater has a pressure switch to detect a blocked vent or air supply. If the flue or air supply ducts are blocked the pressure switch will not allow heater to continue operation. Check flue/air supply duct for obstructions; remove any obstructions.

Check for loose/leaky air hoses to the pressure switch; repair/replace/tighten hoses as required.

Pressure switch does not operate.

Check flue/air supply duct for obstructions; remove any obstructions. Check for loose/leaky air hoses to the pressure switch; repair/replace/tighten hoses as required. Check for 24V across the secondary terminals 4 and 5 (red and yellow wires) of the transformer.
 IF NO: Check for 120V across the primary terminals 1 and 3 (black and white wires) of the transformer. If 120V is present, replace transformer. If 120V is not present, check wiring between power cord, blower motor and transformer.
 IF YES: Connect a jumper wire across pressure switch terminals; if jumper wire allows blower to operate, replace pressure switch.
 See *Page 52, Section 15.1* for part number that applies to your unit rating. Do not resume normal heater operation until replacement pressure switch has been installed.

Igniter spark gap incorrect.

Reset spark gap to 1/8" (3.175 mm).

BURNER DOES NOT LIGHT

Possible Cause

Air in the gas line.

Try this....

Purge gas lines.

Improper gas inlet pressure.

Check gas inlet pressure at the supply line. Gas inlet pressure should be as follows:

Natural Gas: 5.0" wc (12.4 mbar) minimum;
14.0" wc (34.8 mbar) maximum

LP Gas: 11.0" wc (27.4 mbar) minimum;
14.0" wc (34.8 mbar) maximum

If gas inlet pressure does not meet inlet pressure requirements, contact the gas company.

Gas valve does not open.

Check for 24 V across valve terminals.

IF NO: Check wiring between the ignition module and the valve. Repair/replace wires as required. If wiring is OK, replace ignition module.

IF YES: Replace gas valve.

Low gas outlet pressure.

Check gas manifold pressure. Measure manifold pressure at the pressure tap on the gas valve. See *Page 42, Figure 37 and Page 46, Figure 38*.

Natural Gas: 3.5" wc (8.7 mbar)

LP Gas: 10.5" wc (26.1 mbar)

If manifold pressure does not meet requirements, adjust valve outlet pressure with the adjustment screw on the valve.

NOTE: Proper inlet gas pressure must be verified before performing outlet pressure testing.

FIGURE 38: Manometer Reading

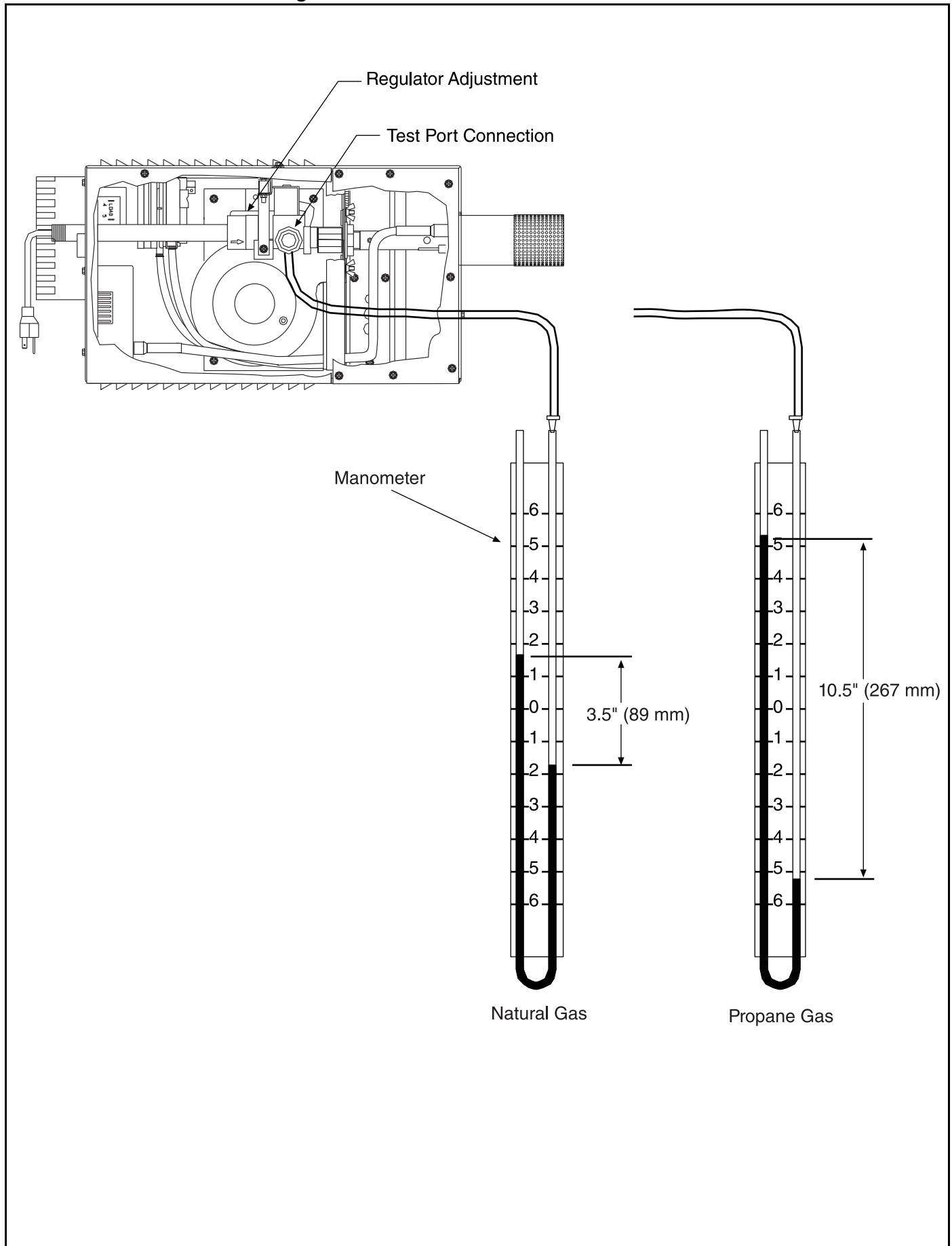

BURNER DOES NOT STAY LIT**Possible Cause****Try this....**

Damaged wires between DSI module and sensing electrode.

Replace wires as required.

Faulty DSI module.

Replace DSI module.

Cracked ceramic at the sensing electrode.

Replace electrode.

Recirculation of exhaust gases.

Check that the 3" (8 cm) inner vent pipe is completely sealed.

BURNER CYCLES ON AND OFF TOO QUICKLY**Possible Cause****Try this....**

Anticipator setting on the thermostat is too low

Adjust the anticipator setting to 0.6. See Page 25, Figure 15.

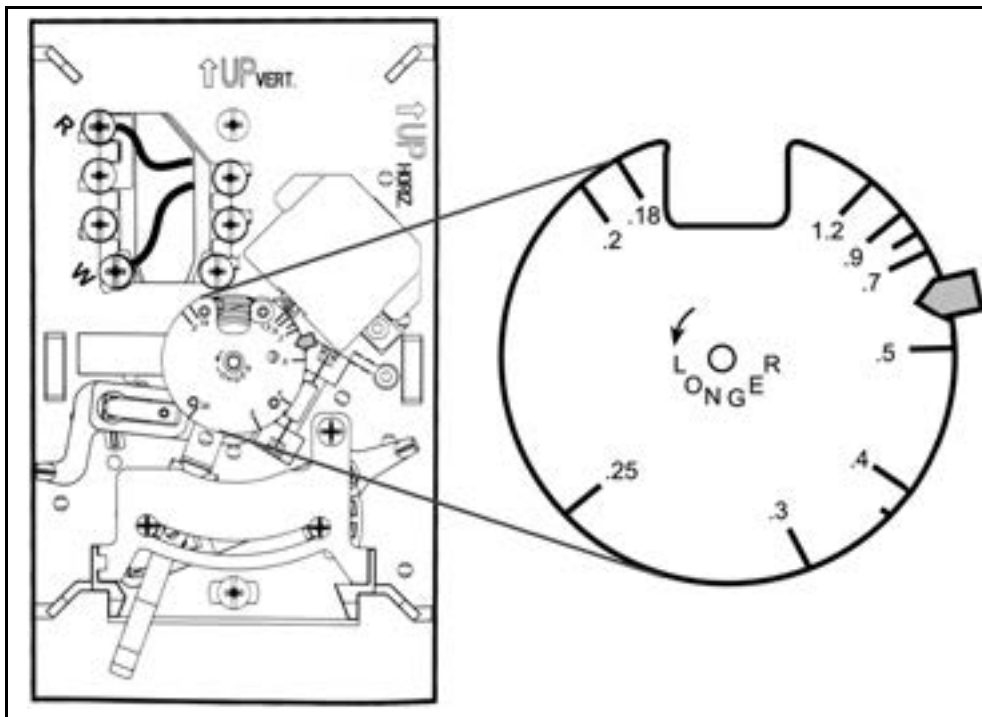
**BURNER MAKES VIBRATING NOISES WHILE RUNNING****Possible Cause****Try this....**





Motor Vibration

Ensure that the shipping screw has been removed from the control housing door. See Page 21, Section 8.7.

Protective Grille metal fingers touch reflector

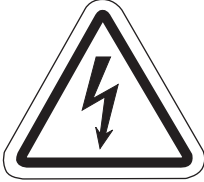
Isolate the grille finger that is making the noise and cap it with a silicone cap. See Page 25, Figure 15.

SECTION 14: MAINTENANCE

⚠ DANGER		⚠ WARNING	
			
<p>Electrical Shock Hazard</p> <p>Disconnect electric before service.</p> <p>Replace door before operating.</p> <p>Heater must be connected to a properly grounded electrical source.</p>	<p>Explosion Hazard</p> <p>Turn off gas supply to heater before service.</p>	<p>Burn Hazard</p> <p>Allow heater to cool before service.</p> <p>Tubing may still be hot after operation.</p>	<p>Cut/Pinch Hazard</p> <p>Wear protective gear during installation, operation and service.</p> <p>Edges are sharp.</p>
<p>Failure to follow these instructions can result in death, electric shock, injury or property damage.</p>			

14.1 Pre-Season Maintenance and Annual Inspection

To ensure your safety and years of trouble-free operation of the heating system, service and annual inspections must be done by a contractor qualified in the installation and service of gas-fired heating equipment.

Turn off gas and electric supplies before performing service or maintenance. Allow heater to cool before servicing.

Before every heating season, a contractor qualified in the installation and service of gas-fired heating equipment must perform a thorough safety inspection of the heater.

For best performance, the gas, electrical, thermostat connections, tubing, venting, suspensions and overall heater condition should be thoroughly inspected.

NOTE: Gas flow and burner ignition are among the

first things that should be inspected.

Please See *Page 48* for suggested items to inspect.

Installation Code and Annual Inspections:

All installation and service of ROBERTS GORDON® equipment must be performed by a contractor qualified in the installation and service of equipment sold and supplied by Roberts-Gordon LLC and conform to all requirements set forth in the ROBERTS GORDON® manuals and all applicable governmental authorities pertaining to the installation, service, operation and labeling of the equipment. To help facilitate optimum performance and safety, Roberts-Gordon LLC recommends that a qualified contractor conduct, at a minimum, annual inspections of your ROBERTS GORDON® equipment and perform service where necessary, using only replacement parts sold and supplied by Roberts-Gordon LLC.

The Vicinity of the Heater Due to high temperature, ensure that the heater is kept clear of clothing, furniture, draperies or other combustible materials, gasoline and other flammable vapors and liquids. See *Page 15, Section 7*, the thermostat wall tag or clearance to combustibles label on the heater.

Vehicles and Other Objects Maintain the clearances to combustibles.

Do not hang anything from, or place anything on, the heater.





Make sure nothing is lodged underneath the reflector, in between the tubes or in the decorative or protective grilles (included with select models).

Immediately remove objects in violation of the clearances to combustibles.

See *Page 15, Section 7*.

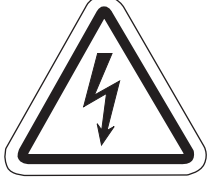
Reflector	<p>Support reflector with reflector hanger.</p> <p>Reflector must not touch tube.</p> <p>Make sure there is no dirt, sagging, cracking or distortion.</p> <p>Do not operate if there is sagging, cracking or distortion.</p> <p>Clean outside surface with a damp cloth.</p>
Vent Pipe	<p>Venting must be intact. Using a flashlight, look for obstructions, cracks on the pipe, gaps in the sealed areas or corrosion.</p> <p>The area must be free of dirt and dust. Clean as required.</p> <p>Remove any carbon deposits or scale using a wire brush.</p> <p>After cleaning as necessary, re-attach the flue pipe to the heater.</p> <p>See <i>Page 27, Section 9.</i></p>
Outside Air Inlet	<p>Inlet must be intact. Look for obstructions, cracks on the pipe, gaps in the sealed areas or corrosion.</p> <p>The area must be free of dirt and dust. Clean and reinstall as required.</p>
Tubes	<p>Make sure there are no cracks.</p> <p>Make sure tube is connected and suspended securely.</p> <p>See <i>Page 21, Section 8.6 through Page 25, Section 8.13.</i></p> <p>Make sure there is no sagging, bending or distortion.</p> <p>Clean or replace as required.</p>
Gas Line	<p>Check for gas leaks. See <i>Page 40, Section 11.</i></p>
Burner Observation Window	<p>Make sure it is clean and free of cracks or holes.</p> <p>Clean and replace as required.</p>
Blower Scroll, Wheel and Motor	<p>Compressed air or a vacuum cleaner may be used to clean dust and dirt.</p>
Burner Cup and Orifice	<p>Clear of obstructions (even spider webs will cause problems).</p> <p>Carefully remove any dust and debris from the burner.</p>
Direct Spark Igniter	<p>Inspect the igniter. Replace igniter if there is excessive carbon residue, erosion of electrodes or other defects.</p> <p>Replace if cracked or broken.</p>
Thermostat	<p>There should be no exposed wire or damage to the device or wiring.</p> <p>See <i>Page 36, Section 10.</i></p>
Suspension Points	<p>Make sure the heater is hanging securely.</p> <p>Look for signs of wear on the chain or ceiling.</p> <p>See <i>Page 21, Figure 10.</i></p>
Protective Grille (select models)	<p>The grille must be securely attached.</p> <p>See <i>Page 25, Section 8.13.</i></p>
Silicone Tubing	<p>Ensure tight, secure fit on all pressure fittings and pressure switch.</p>
Thermostat Tag	<p>If wall tag is present, make sure it is legible and accurate. Please contact Roberts-Gordon LLC or your ROBERTS GORDON® independent distributor, if you need a wall tag. See <i>Page 11, Section 5.4.</i></p>
Safety Labels	<p>Product safety signs or labels should be replaced by the product user when they are no longer legible. Please contact Roberts-Gordon LLC or your ROBERTS GORDON® independent distributor to obtain replacement signs or labels. <i>Page 3, Figure 1 through Page 4, Figure 2.</i></p>

SECTION 15: REPLACEMENT PARTS

⚠ DANGER	⚠ WARNING		
			
Electrical Shock Hazard	Explosion Hazard	Fire Hazard	Carbon Monoxide Hazard
Use only genuine ROBERTS GORDON® replacement parts per this installation, operation and service manual.			
Failure to follow these instructions can result in death, electric shock, injury or property damage.			

This section contains the part numbers and pictorials for components of the CGTH-Series heater. Call out letters on the illustrations refer directly to the associated parts list.

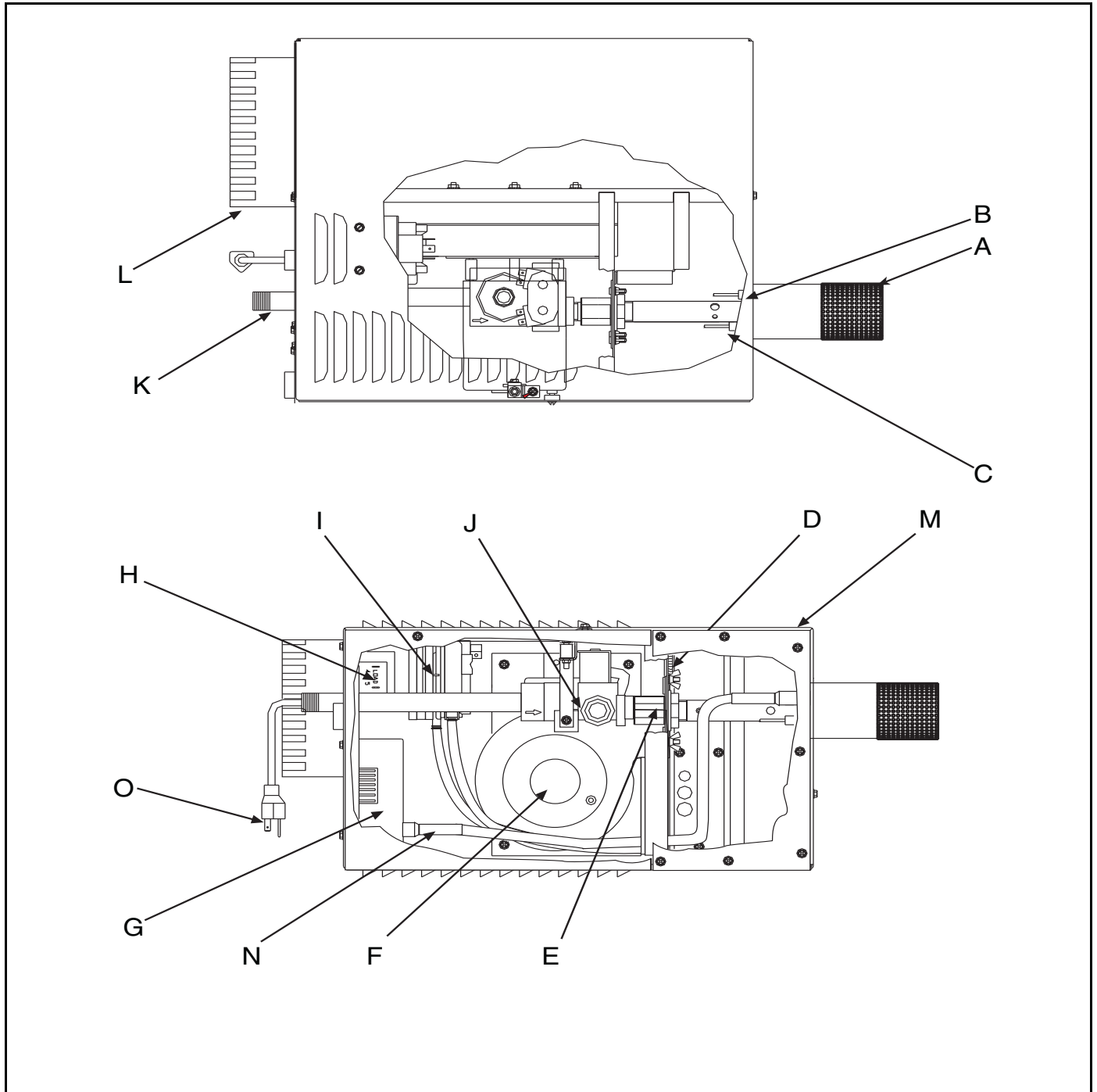
FIGURE 39: Illustrated Parts List

15.1 Replacement Parts List for Burner

Item	Part Number	Description	CGTH-30	CGTH-40	CGTH-50
A	08117000	Burner Cup Assembly	1	1	1
B	90439300	Flame Sensor	1	1	1
C	90439101K	Igniter, Primary	1	1	1
D	02553203	Mica Window Assembly	1	1	1
E	08018000	Adapter, Orifice Holder	1	1	1
F	90710201-P	Motor/Blower	1	1	1
G	90434009K	Ignition Module	1	1	1
H	90436900K	Transformer	1	1	1
I	90439806K	Pressure Switch	1	-	-
	90439804K	Pressure Switch	-	1	-
	90439802K	Pressure Switch	-	-	1
J	90034500	Gas Valve (Natural Gas)	1	1	1
	90034600	Gas Valve (LP Gas)	1	1	1
K	91201618	Pipe Nipple	1	1	1
L	08031500	Flue Collar 5" (13 cm)	1	1	1
M	08115100	Door Gasket	1	1	1
N	90427706	Ignition Cable	1	1	1
O	91306405	Power Cord	1	1	1

15.2 Illustrated Parts List for Tube and Reflector

FIGURE 40: Tube and Reflector

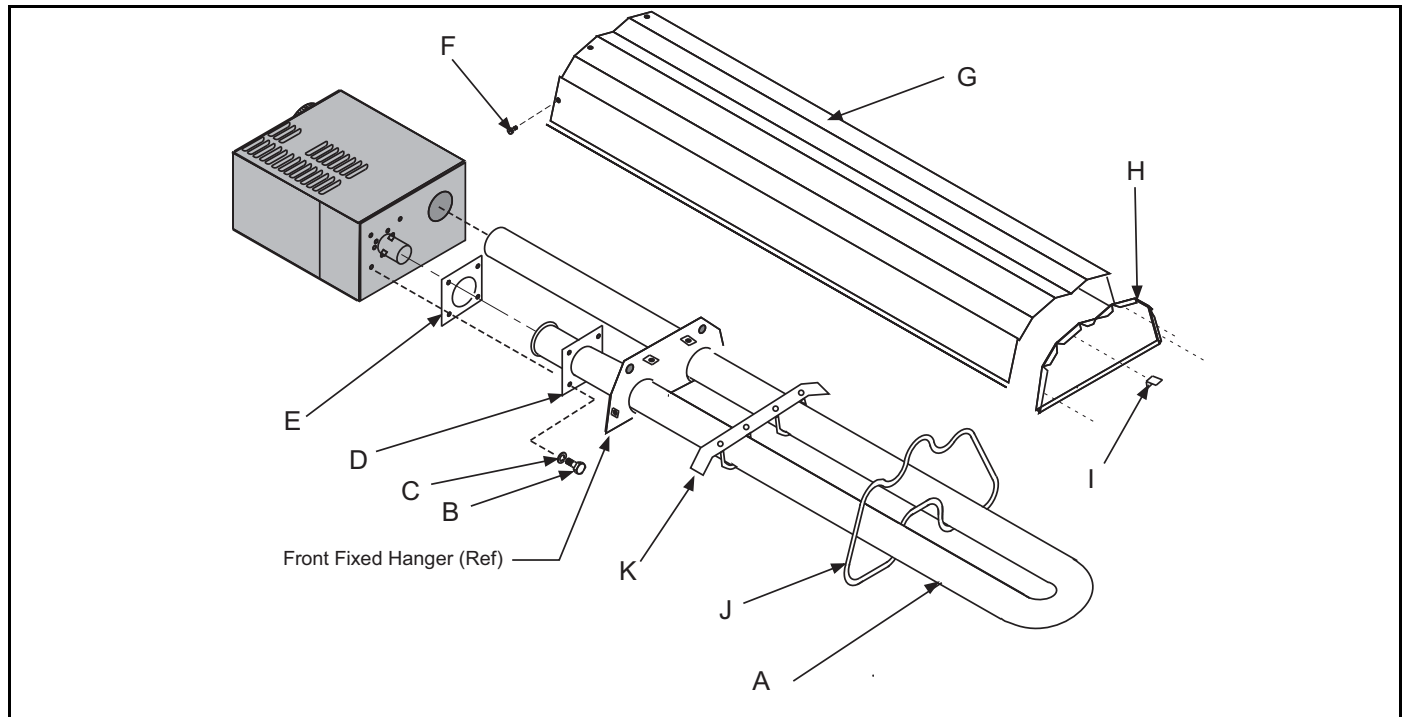

15.3 Replacement Parts List for Tube & Reflector

Item	Part Number	Description	CGTH-30	CGTH-40	CGTH-50
A	08020001	Heat Exchanger Assembly (8') (2.5 m)	1	-	-
	08021001	Heat Exchanger Assembly (11'6") (3.5 m)	-	1	1
B	94273914	Bolt Rolok® Hex HD 5/16-18 x 7/8	4	4	4
C	96411600	Lockwasher 5/16 Helical Spring	4	4	4
D	08023000	Support Plate	1	1	1
E	08070000	Burner Tube Gasket	1	1	1
F	-	Screw (#8 x 3/8")	4	4	4
G	08090000	Reflector (80") (203 cm)	1	-	-
	08090001	Reflector (120") (305 cm)	-	1	1
H	02750800	End Cap	1	1	1
I	91107720*	U-Clips	4	4	4
J	08080000	Rear Reflector Hanger (Moveable)	1	1	1
K	08061000	Support Plate	-	1	1
	08062000	Support U-bolt	-	2	2

(*) Part number shown is for reorder purposes and represents a package of 20 pieces.

SECTION 16: THE ROBERTS GORDON® BLACKHEAT™ GH WARRANTY

ROBERTS-GORDON WILL PAY FOR:

Within 36 months from date of purchase by buyer or 42 months from date of shipment by Roberts-Gordon LLC (whichever occurs first), replacement parts will be provided free of charge for any part of the product which fails due to a manufacturing or material defect.

Roberts-Gordon LLC will require the part in question to be returned to the factory. Roberts-Gordon LLC will, at its sole discretion, repair or replace after determining the nature of the defect and disposition of part in question.

ROBERTS GORDON® Replacement Parts are warranted for a period of 12 months from date of shipment from Roberts-Gordon LLC or the remaining ROBERTS GORDON® BLACKHEAT™ GH warranty.

ROBERTS-GORDON WILL NOT PAY FOR:

Service trips, service calls and labor charges.

Shipment of replacement parts.

Claims where the total price of the goods have not been paid.

Damage due to:

- Improper installation, operation or maintenance.
- Misuse, abuse, neglect, or modification of the ROBERTS GORDON® BLACKHEAT™ GH in any way.
- Use of the ROBERTS GORDON® BLACKHEAT™ GH for other than its intended purpose.
- Incorrect gas or electrical supply, accident, fire, floods, acts of God, war, terrorism, or other casualty.
- Improper service, use of replacement parts or accessories not specified by Roberts-Gordon.
- Failure to install or maintain the ROBERTS GORDON® BLACKHEAT™ GH as directed in the Installation, Operation and Service manual.
- Relocation of the ROBERTS GORDON® BLACKHEAT™ GH after initial installation
- The use of the ROBERTS GORDON® BLACKHEAT™ GH in a corrosive atmosphere containing contaminants.
- The use of the ROBERTS GORDON® BLACKHEAT™ GH in the vicinity of a combustible or explosive material.
- Any defect in the ROBERTS GORDON® BLACKHEAT™ GH arising from a drawing, design, or specification supplied by or on behalf of the consumer.
- Damage incurred during shipment. Claim must be filed with carrier.

WARRANTY IS VOID IF:

The ROBERTS GORDON® BLACKHEAT™ GH is not installed by an electrician qualified in the installation and service of gas fired heating equipment.

You cannot prove original purchase date and required annual maintenance history.

The data plate and/or serial number are removed, defaced, modified or altered in any way.

The ownership of the ROBERTS GORDON® BLACKHEAT™ GH is moved or transferred. This warranty is nontransferable.

Roberts-Gordon LLC is not permitted to inspect the damaged controller and/or component parts.

READ YOUR INSTALLATION, OPERATION AND SERVICE MANUAL

If you have questions about your controller, contact your installing professional. Should you need Replacement Parts or have additional questions, call or write:

Roberts-Gordon LLC

1250 William Street

P.O. Box 44

Buffalo, New York 14240-0044

Telephone: +1.716.852.4400

Fax: +1.716.852.0854

Toll Free: 800.828.7450

www.rg-inc.com

Roberts-Gordon LLC's liability, and your exclusive remedy, under this warranty or any implied warranty (including the implied warranties of merchantability and fitness for a particular purpose) is limited to providing replacement parts during the term of this warranty. Some jurisdictions do not allow limitations on how long an implied warranty lasts, so this limitation may not apply to you. There are no rights, warranties or conditions, expressed or implied, statutory or otherwise, other than those contained in this warranty.

Roberts-Gordon LLC shall in no event be responsible for incidental or consequential damages or incur liability for damages in excess of the amount paid by you for the ROBERTS GORDON® BLACKHEAT™ GH.

Some jurisdictions do not allow the exclusion or limitation of incidental or consequential damages, so this limitation or exclusion may not apply to you. This warranty gives you specific legal rights, and you may also have other rights which vary from jurisdiction to jurisdiction.

Roberts-Gordon LLC shall not be responsible for failure to perform under the terms of this warranty if caused by circumstances out of its control, including but not limited to war, fire, flood, strike, government or court orders, acts of God, terrorism, unavailability of supplies, parts or power. No person is authorized to assume for Roberts-Gordon LLC any other warranty, obligation or liability.

LIMITATIONS ON AUTHORITY OF REPRESENTATIVES:

No representative of Roberts-Gordon LLC, other than an Executive Officer, has authority to change or extend these provisions. Changes or extensions shall be binding only if confirmed in writing by Roberts-Gordon LLC's duly authorized Executive Officer.



OWNER WARRANTY REGISTRATION CARD

Mail or Fax to:
Roberts Gordon LLC • 1250 William Street, P.O. Box 44 • Buffalo, NY 14240-0044 • Phone: 716-852-4400 • Fax: 716-852-0854
Toll Free: 800-828-7450 • www.rg-inc.com

About the Owner:

Name: _____
Address: _____ City: _____ State: _____ Zip Code: _____
Phone: _____ Fax: _____ E-mail: _____

About the Installer:

Name: _____
Address: _____ City: _____ State: _____ Zip Code: _____
Phone: _____ Fax: _____ E-mail: _____

Purchased From (if different than installer):

Name: _____
Address: _____ City: _____ State: _____ Zip Code: _____
Phone: _____ Fax: _____ E-mail: _____

About your Heater:

Model #: _____ Serial #: _____ Fuel: _____ Installation Date: _____

Type of Installation (check one):

- Automotive Manufacturing Warehouse Recreational Aircraft
- Public Building Office Retail Agricultural Other _____

Installation Code and Annual Inspections: All installation and service of ROBERTS GORDON® equipment must be performed by a contractor qualified in the installation and service of equipment sold and supplied by Roberts-Gordon LLC and conform to all requirements set forth in the ROBERTS GORDON® manuals and all applicable governmental authorities pertaining to the installation, service, operation and labeling of the equipment.

To help facilitate optimum performance and safety, Roberts-Gordon LLC recommends that a qualified contractor conduct, at a minimum, annual inspections of your ROBERTS GORDON® equipment and perform service where necessary, using only replacement parts sold and supplied by Roberts-Gordon LLC.

These products are not for residential use.

This product is intended to assist licensed professionals in the exercise of their professional judgment.

