

# VANTAGE™

ROBERTS GORDON™

## Low-Intensity Infrared Heating Systems Submittal: HEM Series



Job: \_\_\_\_\_  
 Location: \_\_\_\_\_  
 Engineer: \_\_\_\_\_  
 Gas Specs: \_\_\_\_\_  
 Date: \_\_\_\_\_

QTY.	_____	MODEL NO. HEM	_____	UNIT INPUT	_____	BTU/HR
QTY.	_____	MODEL NO. HEM	_____	UNIT INPUT	_____	BTU/HR
QTY.	_____	MODEL NO. HEM	_____	UNIT INPUT	_____	BTU/HR
QTY.	_____	MODEL NO. HEM	_____	UNIT INPUT	_____	BTU/HR
TOTAL INPUT				_____	BTU/HR	_____

**Important**

**Before installation and operation of heating equipment, read and understand the Installation, Operation and Service Manual.**

Applications, engineering and detailed guidance on systems design, installation and product performance is available upon request. ROBERTS GORDON® products are to be installed only in accordance with local laws, codes and regulations, and only by a contractor qualified in the installation and service of gas-fired heating equipment.



**Roberts-Gordon**  
 1250 William Street  
 P.O. Box 44  
 Buffalo, New York 14240-0044  
 Telephone: 716.852.4400  
 Fax: 716.852.0854  
 Toll Free: 800.828.7450

[www.robertsgordon.com](http://www.robertsgordon.com)

# Model HEM Gas-Fired, Low Intensity Unitary Heater

## Installation, Operation & Service Manual

HEM-80  
HEM-115  
HEM-150  
HEM-200

### FOR YOUR SAFETY

#### *If you smell gas:*

1. Open windows.
2. **DO NOT** try to light any appliance.
3. **DO NOT** use electrical switches.
4. **DO NOT** use any telephone in your building.
5. Extinguish any open flame.
6. Leave the building.
7. Immediately call your local gas supplier after leaving the building. Follow the gas supplier's instructions.
8. If you cannot reach your gas supplier, call the Fire Department.

### ⚠ WARNING



#### Fire Hazard

Keep all flammable objects, liquids and vapors the minimum required clearances to combustibles away from heater.

Some objects will catch fire or explode when placed close to heater.

Failure to follow these instructions can result in death, injury or property damage.

### ⚠ WARNING

Improper installation, adjustment, alteration, service or maintenance can result in death, injury or property damage. Read the Installation, Operation and Service Manual thoroughly before installing or servicing this equipment.

Installation must be done by a contractor qualified in the installation and service of gas-fired heating equipment or your gas supplier.

#### Installer

Please take the time to read and understand these instructions prior to any installation. Installer must give a copy of this manual to the owner.

#### Owner

Keep this manual in a safe place in order to provide your service technician with necessary information.



#### Roberts-Gordon LLC

1250 William Street  
P.O. Box 44  
Buffalo, New York 14240-0044  
Telephone: +1.716.852.4400  
Fax: +1.716.852.0854  
Toll Free: 800.828.7450

[www.robertsgordon.com](http://www.robertsgordon.com)



## TABLE OF CONTENTS

<b>SECTION 1: Heater Safety</b> .....	1	10.2 Central and Satellite Heaters (Zoning Capability) ....	46
1.1 Manpower Requirements .....	1	10.3 Communication Wiring within a Zone of Heaters .....	48
1.2 Safety Labels and Their Placement .....	1	10.3 Communication Wiring within a Zone of Heaters (continued) .....	49
1.3 California Proposition 65 .....	1	10.4 Heat Demand Control Wiring .....	50
<b>SECTION 2: Installer Responsibility</b> .....	4	10.5 Potentiometer with On/Off Control .....	57
2.1 Wall Tag .....	4	10.6 Internal Wiring .....	58
2.2 Corrosive Chemicals .....	4	10.7 Ladder Diagram .....	59
2.3 National Standards and Applicable Codes .....	4	10.8 Line Voltage Power Wiring .....	59
<b>SECTION 3: Clearances to Combustibles</b> .....	5	10.9 Electrical Connection to the Burner Box using Line Voltage Thermostat on Control .....	60
3.1 Required Clearances to Combustibles .....	5	10.10 Low Voltage Control Wiring Installation .....	61
<b>SECTION 4: National Standards and Applicable Codes</b> .....	9	<b>SECTION 11: Operation and Maintenance</b> .....	62
4.1 Gas Codes .....	9	11.1 Sequence of Operation .....	62
4.2 Aircraft Hangars .....	9	11.2 To Shut Off Heater .....	62
4.3 Public Garages .....	9	11.3 To Start Heater .....	62
4.4 Electrical .....	9	11.4 Pre-Season Maintenance and Annual Inspection .....	62
4.5 Venting .....	9	<b>SECTION 12: Troubleshooting</b> .....	65
4.6 High Altitude .....	9	12.1 Control LED .....	65
<b>SECTION 5: Major Components</b> .....	10	12.2 General LED Codes .....	65
5.1 Standard Parts List .....	12	12.3 Troubleshooting Flow Chart .....	67
<b>SECTION 6: Heater Installation</b> .....	15	12.4 Manifold Gas Pressure Measurement .....	69
6.1 Outdoor Mounting .....	17	12.5 Pneumatic Connections .....	70
6.6 Reflector Installation .....	23	<b>SECTION 13: Replacement Parts</b> .....	71
<b>SECTION 7: Optional Heater Accessories</b> .....	26	<b>SECTION 14: General Specifications</b> .....	74
7.1 U-Tube Configuration .....	26	14.1 Material Specifications .....	74
7.2 Elbow Package Configuration .....	29	14.2 Heater Specifications .....	74
7.3 Reflector Side Extension .....	31	14.3 Suspension Specifications .....	74
7.4 Lower Clearance Shield Installation .....	32	14.4 Controls Specifications .....	74
7.5 Two-Foot Decorative Grille Installation .....	32	<b>SECTION 15: The ROBERTS GORDON® VANTAGE® HEM War-</b>	
7.6 Protective Grille Installation .....	34	<b>ranty</b> .....	75
<b>SECTION 8: Venting</b> .....	35		
8.1 Venting .....	35		
8.2 Unvented Operation .....	35		
8.3 Horizontal Venting .....	36		
8.4 Vertical Venting .....	36		
8.5 Unvented Operation Tube Termination .....	36		
8.6 Length Requirements .....	36		
8.7 Venting Options .....	38		
8.8 Horizontal Ventilation 4" (10 cm) Pipe .....	38		
8.9 Vertical Ventilation 4" (10 cm) Pipe .....	39		
8.10 Common Side Wall Venting .....	39		
8.11 Common Vertical Venting .....	40		
8.12 Outside Combustion Air Supply .....	41		
<b>SECTION 9: Gas Piping</b> .....	43		
<b>SECTION 10: Wiring</b> .....	45		
10.1 Standard Heater Configuration .....	45		

© 2018 Roberts-Gordon LLC

All rights reserved. No part of this work covered by the copyrights herein may be reproduced or copied in any form or by any means - graphic, electronic, or mechanical, including photocopying, recording, taping or information storage and retrieval systems - without the written permission of Roberts-Gordon LLC.



## SECTION 1: HEATER SAFETY



Your Safety is Important to Us!  
This symbol is used throughout the manual to notify you of possible fire, electrical or burn hazards. Please pay special attention when reading and following the warnings in these sections.

Installation, service and annual inspection of heater must be done by a contractor qualified in the installation and service of gas-fired heating equipment.

Read this manual carefully before installation, operation or service of this equipment.

This heater is designed for heating nonresidential indoor spaces. Do not install in residential spaces. This heater is not certified to meet the requirements of NFPA30A-2012 Section 7.6.6. (maximum tube temperature of 750 °F (399 °C)). Do not install this heater in facilities where compressed natural gas (CNG) or liquid natural gas (LNG) are present. These instructions, the layout drawing, local codes and ordinances, and applicable standards that apply to gas piping, electrical wiring, venting, etc. must be thoroughly understood before proceeding with the installation.

Protective gear is to be worn during installation, operation and service in accordance to the Occupational Safety and Hazard Administration (OSHA). Gear must be in accordance to NFPA 70E, latest revision when working with electrical components. Thin sheet metal parts have sharp edges. To prevent injury, the use of work gloves is recommended. The use of gloves will also prevent the transfer of body oils from the hands to the surface of the reflector.

Before installation, check that the local distribution conditions, nature of gas and pressure, and adjustment of the appliance are compatible.

This heater must be applied and operated under the general concepts of reasonable use and installed using best building practices.

This appliance is not intended for use by persons (including children) with reduced physical, sensory or mental capabilities, or lack of experience and knowledge, unless they have been given supervision or instruction concerning use of the appliance by a person responsible for their safety. Children should be supervised to ensure that they do no play with the appliance.

For additional copies of the Installation, Operation and Service Manual, please contact Roberts-Gordon LLC.

### 1.1 Manpower Requirements

To prevent personal injury and damage to the heater, two persons will be required for installation.

### 1.2 Safety Labels and Their Placement

Product safety signs or labels should be replaced by the product user when they are no longer legible. Please contact Roberts-Gordon or your ROBERTS GORDON® independent distributor to obtain replacement signs or labels. See *Page 2, Figure 1 through Page 3, Figure 2*.

### 1.3 California Proposition 65

In accordance with California Proposition 65 requirements, a warning label must be placed in a highly visible location on the outside of the equipment (i.e., near equipment's serial plate). See label placement drawing *and Page 2, Figure 1* for label location. Avoid placing label on areas with extreme heat, cold, corrosive chemicals or other elements. To order additional labels, please contact Roberts-Gordon LLC or your ROBERTS GORDON® independent distributor.

FIGURE 1: Top and Bottom Panel Label Placement

**Bottom Panel**

**Top Panel**

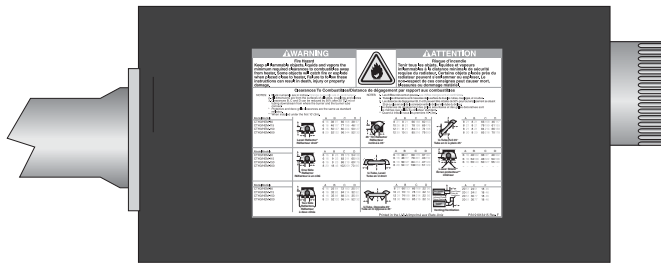
**Logo Label**

**Rating Plate Label**

**Vent Length Label**

Description	Part Number
Logo Label	91013221
Rating Plate Label	91010401
Gas Connection Label	91018122
Proposition 65 Label (Not Shown)	91070016
Vent Length Label	91039500

FIGURE 2: Side and Back Panel Label Placement



Control Side Panel

**WARNING**  
Fire Hazard  
Keep all flammable objects, liquids and vapors the minimum required clearances to combustibles away from heater. Some objects will catch fire or explode when placed close to heater. Failure to follow these instructions can result in death, injury or property damage.

**ATTENTION**  
Risque d'incendie  
Tenir tous les objets, liquides et vapeurs inflammables à la distance minimale de sécurité requise du radiateur. Certains objets placés près du radiateur peuvent s'enflammer ou exploser. Le non-respect de ces consignes peut causer mort, blessures ou dommages matériels.

**Clearances to Combustibles/Distance de dégagement par rapport aux combustibles**

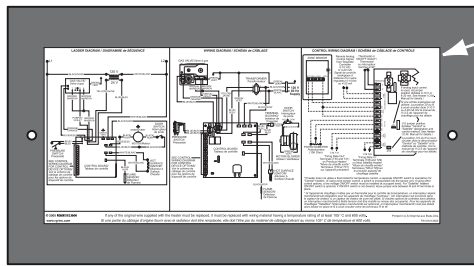
NOTES:  
1. Black numerals are in inches. C and D are in centimeters.  
2. All clearances are from the surfaces of all tubes, except 1/2" and elbows.  
3. Materials A, C and D can be reduced by 50% after 24 hours of tubing downstream from where the burner and the burner tube meet.  
\* Protective and deco grille clearances are the same as standard reflector.  
\* When installed under the 10" (25cm).

Model/Modèle: CTH3HEM-40, CTH3HEM-45, CTH3HEM-100, CTH3HEM-200

Level Reflector / Réflecteur droit, 45°-Tilt Reflector / Réflecteur incliné à 45°, U-Tube Level / Tube en U droit, U-Tube 45° / Tube en U à 45°, One Side Reflector / Réflecteur à un côté, Two Side Reflector / Réflecteur à deux côtés, Lower Shear / Écrou protecteur inférieur, Venting/Ventilation

Printed in the U.S.A./Imprimé aux États-Unis P/N 91013415 Rev. F

Clearances to Combustibles Label

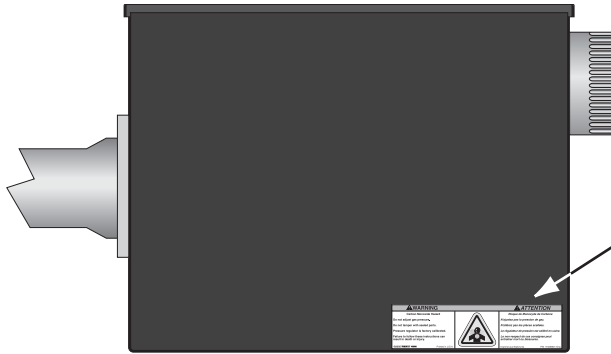


Control Side Panel (Inside)

**Wiring Label**

Labels include: LOW VOLTAGE CONNECTION / CONNEXION DE CÂBLAGE DE CONTRÔLE, WIRING DIAGRAM / SCHEMA DE CÂBLAGE, CONTROL WIRING DIAGRAM / SCHEMA DE CÂBLAGE DE CONTRÔLE.

© 2005 ROBERTS-GORDON Printed in U.S.A. / Imprimé aux États-Unis P/N 91013303



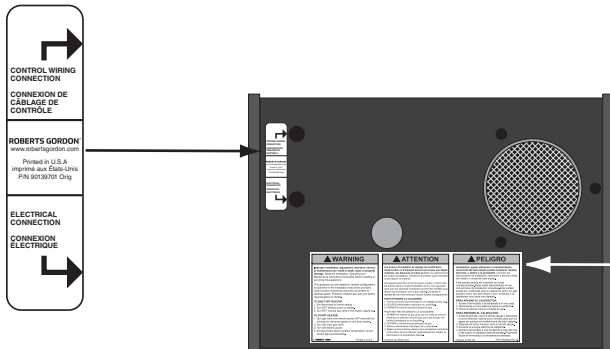
Inside Bottom Panel

**WARNING**  
Carbon Monoxide Hazard  
Do not adjust gas pressure.  
Do not tamper with sealed parts.  
Pressure regulator is factory calibrated.  
Failure to follow these instructions can result in death or injury.

**ATTENTION**  
Risque de Monoxyde de Carbone  
N'ajustez pas la pression de gaz.  
N'altérez pas les pièces scellées.  
Le régulateur de pression est calibré en usine.  
Le non-respect de ces consignes peut entraîner mort ou blessures.

©2005 ROBERTS-GORDON Printed in U.S.A. / Imprimé aux États-Unis P/N 91039501 Orig

Carbon Monoxide Hazard Label



Back Panel

**WARNING**  
Improper installation, adjustment, alteration, service or maintenance can result in death, injury or property damage. Read the installation, operating and maintenance instructions thoroughly before installing or servicing this equipment.

**ATTENTION**  
Les erreurs d'installation de réglage ou modification, l'entretien ou l'entretien peuvent entraîner des décès, blessures, et dommages à la propriété. Lire attentivement les instructions d'installation, d'exploitation et de maintenance avant d'installer ou de servir ce matériel.

**PELIGRO**  
Instalación, ajuste alteración o mantenimiento incorrectos de este equipo pueden ocasionar muerte, lesiones, e daños a la propiedad. Lea bien las instrucciones de instalación, operación y servicio antes de instalar o componer este equipo.

1. Turn OFF (French) gas valve in the heater supply line.  
2. Turn OFF (French) gas valve in the heater supply line.  
3. Turn OFF (French) gas valve in the heater supply line.  
4. Turn OFF (French) gas valve in the heater supply line.  
5. Turn OFF (French) gas valve in the heater supply line.

1. Fermer le robinet à gaz (français) au niveau de la ligne d'alimentation en gaz.  
2. Fermer le robinet à gaz (français) au niveau de la ligne d'alimentation en gaz.  
3. Fermer le robinet à gaz (français) au niveau de la ligne d'alimentation en gaz.  
4. Fermer le robinet à gaz (français) au niveau de la ligne d'alimentation en gaz.  
5. Fermer le robinet à gaz (français) au niveau de la ligne d'alimentation en gaz.

1. Apagar el interruptor de gas (español) en la línea de suministro de gas.  
2. Apagar el interruptor de gas (español) en la línea de suministro de gas.  
3. Apagar el interruptor de gas (español) en la línea de suministro de gas.  
4. Apagar el interruptor de gas (español) en la línea de suministro de gas.  
5. Apagar el interruptor de gas (español) en la línea de suministro de gas.

© 2005 ROBERTS-GORDON Printed in U.S.A. / Imprimé aux États-Unis P/N 91029602 Orig

Lighting Instruction Plate Label

Description	Part Number
Clearances to Combustibles Label	91013415
Wiring Label	91013303
Carbon Monoxide Hazard Label	91039501
Low Voltage Connection Label	91039701
Lighting Instruction Plate Label	91029602



## SECTION 2: INSTALLER RESPONSIBILITY

The installer is responsible for the following:

- To install the heater, as well as the gas and electrical supplies, in accordance with applicable specifications and codes. Roberts-Gordon LLC recommends the installer contact a local Building Inspector or Fire Marshal for guidance.
- To use the information given in a layout drawing and in the manual together with the cited codes and regulations to perform the installation.
- To install the heater in accordance with the clearances to combustibles.
- To furnish all needed materials not furnished as standard equipment.
- To plan location of supports.
- To provide access to burners for servicing on all sides, for burner removal.
- To provide the owner with a copy of this installation, operation and service manual.
- To never use heater as support for a ladder or other access equipment and never hang or suspend anything from heater.
- To ensure there is adequate air circulation around the heater and to supply air for combustion, ventilation and distribution in accordance with local codes.
- To safely and adequately install heater using materials with a minimal working load of 75 lbs (33 kg).
- To ensure the heater is placed in a approved application.

### 2.1 Wall Tag

A laminated wall tag is available for the heater as a permanent reminder of the safety instructions and the importance of the required clearances to combustibles. Please contact Roberts-Gordon LLC or your ROBERTS GORDON® independent distributor to obtain the wall tag. Affix the tag by peeling off the backing of the adhesive strips on the rear surface and position the tag on a wall near the heater (e.g. thermostat or ROBERTS GORDON® Controller).

A copy of the wall tag (P/N 91037912) is illustrated on the back cover. For an immediate solution, you may affix this copy on the wall near the heater.

Know your model number and installed configuration.

Model number and installed configuration are found on the burner and in the Installation, Operation and Service Manual. See Page 5, Figure 3 through Page 8, Figure 12. Write the proper clearance dimensions in permanent ink according to your model number and configuration in the open spaces on the tag.

### 2.2 Corrosive Chemicals


<p><b>Product Damage Hazard</b></p> <p><b>Do not use heater in area containing corrosive chemicals.</b></p> <p><b>Refer to appropriate Material Safety Data Sheets (MSDS).</b></p> <p><b>Failure to follow these instructions can result in product damage.</b></p>

Roberts-Gordon LLC cannot be responsible for ensuring that all appropriate safety measures are undertaken prior to installation; this is entirely the responsibility of the installer. It is essential that the contractor, the sub-contractor, or the owner identifies the presence of combustible materials, corrosive chemicals or halogenated hydrocarbons\* anywhere in the premises.

*\* **Halogenated Hydrocarbons** are a family of chemical compounds characterized by the presence of halogen elements (fluorine, chlorine, bromine, etc.). These compounds are frequently used in refrigerants, cleaning agents, solvents, etc. If these compounds enter the air supply of the burner, the life span of the heater components will be greatly reduced. An outside air supply must be provided to the burners whenever the presence of these compounds is suspected. Warranty will be invalid if the heater is exposed to halogenated hydrocarbons.*

### 2.3 National Standards and Applicable Codes

All appliances must be installed in accordance with the latest revision of the applicable standards and national codes. This refers also to the electric, gas and venting installation. Note: Additional standards for installations in Public Garages, Aircraft Hangars, etc. may be applicable.

## SECTION 3: CLEARANCES TO COMBUSTIBLES

### 3.1 Required Clearances to Combustibles

Clearances are the required distances that combustible objects must be away from the heater to prevent serious fire hazards. Combustibles are materials, that may catch on fire and include common items such as wood, paper, rubber, fabric, etc.

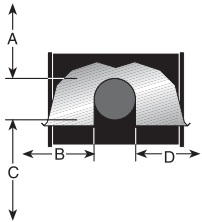
**Maintain clearances to combustibles at all times for safety.**

Clearances for all heater models are located on the burner of the heater and *on Page 5, Figure 3 through Page 8, Figure 12* in this manual. Check the clearances on each burner for the model heater being installed to make sure the product is suitable for your application and the clearances are maintained. Read and follow the safety guidelines below:

- Keep gasoline or other combustible materials including flammable objects, liquids, dust or vapors away from this heater or any other appliance
- The stated clearance to combustible represents a surface temperature of 90° F (32°C) above room temperature. Building materials with a low heat tolerance (such as plastics, vinyl siding, canvas, triply, etc.) may be subject to degradation at lower temperatures. It is the installer's responsibility to assure that adjacent materials are protected from degradation.
- Maintain clearances from heat sensitive equipment and workstations.
- Maintain clearances from vehicles parked below the heater.
- Maintain clearances from swinging and overhead doors, overhead cranes, vehicle lifts, partitions, storage racks, hoists, building construction, etc.

**NOTE:** 1. All dimensions are from the surfaces of all tubes, couplings and elbows.  
2. Clearances B, C and D can be reduced by 50% after 25' (7.5 m) of tubing downstream from where the burner and burner tube connect.

**FIGURE 3: LEVEL REFLECTOR**

	Model	(inches)				(centimeters)			
		A	B	C	D	A	B	C	D
	HEM-80	6	38	66	38	16	97	168	97
	HEM-115	6	46	77	46	16	117	196	117
	HEM-150	6	50	80	50	16	127	204	127
	HEM-200	8	52	96	52	21	133	244	133

## ! WARNING



### Fire Hazard

**Keep all flammable objects, liquids and vapors the minimum required clearances to combustibles away from heater.**

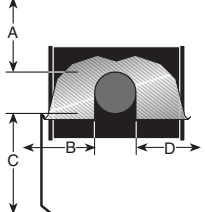
**Some objects will catch fire or explode when placed close to heater.**

**Failure to follow these instructions can result in death, injury or property damage.**

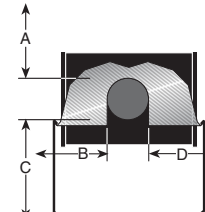
- In locations used for the storage of combustible materials, signs must be posted to specify the maximum permissible stacking height to maintain required clearances from the heater to the combustibles. Signs must be posted adjacent to the heater thermostat. In the absence of a thermostat, signs must be posted in a conspicuous location.
- Consult local Fire Marshal, Fire Insurance Carrier or other authorities for approval of proposed installation when there is a possibility of exposure to combustible airborne materials or vapors.
- Hang heater in accordance to the minimum suspension requirements *on Page 16, Figure 15*.
- If the radiant tubes must pass through the building structure, be sure that adequate sleeving and fire stop is installed to prevent scorching and/or fire hazard.

**NOTE:** 1. All dimensions are from the surfaces of all tubes, couplings and elbows.  
 2. Clearances B, C and D can be reduced by 50% after 25' (7.5 m) of tubing downstream from where the burner and burner tube connect.

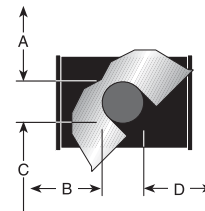
**FIGURE 4: ONE SIDE REFLECTOR**

	Model	(inches)				(centimeters)			
		A	B	C	D	A	B	C	D
	HEM-80	6	9	70	54	16	23	178	138
	HEM-115	6	9	83	65	16	23	211	166
	HEM-150	6	9	86	69	16	23	219	176
	HEM-200	8	18	102	73	21	46	260	186

**FIGURE 5: TWO SIDE REFLECTORS**

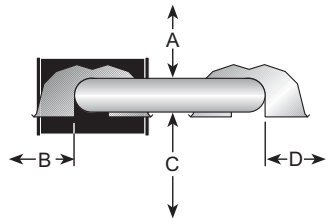
	Model	(inches)				(centimeters)			
		A	B	C	D	A	B	C	D
	HEM-80	6	25	72	25	16	64	183	64
	HEM-115	6	32	84	32	16	82	214	82
	HEM-150	6	35	88	35	16	89	224	89
	HEM-200	8	40	102	40	21	102	260	102

**FIGURE 6: 45° TILT REFLECTOR**

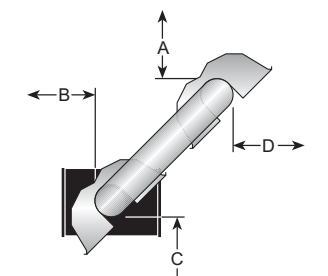
	Model	(inches)				(centimeters)			
		A	B	C	D	A	B	C	D
	HEM-80	8	8	66	60	21	21	168	153
	HEM-115	10	8	78	69	26	21	199	176
	HEM-150	12	8	84	74	31	21	214	188
	HEM-200	12	10	85	79	31	26	216	201

- NOTE:** 1. All dimensions are from the surfaces of all tubes, couplings and elbows.  
 2. Clearances B, C and D can be reduced by 50% after 25' (7.5 m) of tubing downstream from where the burner and burner tube connect.

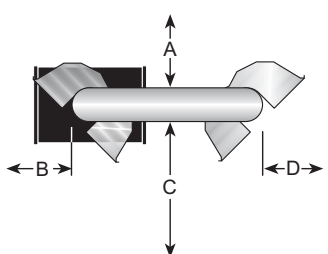
**FIGURE 7: U-TUBE, LEVEL REFLECTOR**

	Model	(inches)				(centimeters)			
		A	B	C	D	A	B	C	D
	HEM-80	6	38	69	37	16	97	176	94
	HEM-115	6	46	79	43	16	117	201	110
	HEM-150	6	50	84	47	16	127	214	120
	HEM-200	8	54	102	51	21	138	260	130

**FIGURE 8: U-TUBE, 45°**

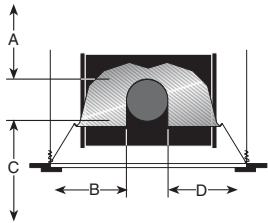
	Model	(inches)				(centimeters)			
		A	B	C	D	A	B	C	D
	HEM-80	8	8	66	46	21	21	168	117
	HEM-115	8	8	78	61	21	21	199	155
	HEM-150	8	8	84	66	21	21	214	168
	HEM-200	8	8	85	70	21	21	216	178

**FIGURE 9: U-TUBE, OPPOSITE 45° REFLECTOR**

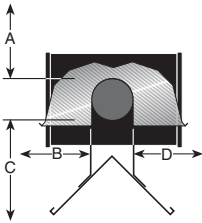
	Model	(inches)				(centimeters)			
		A	B	C	D	A	B	C	D
	HEM-80	8	60	66	22	21	153	168	56
	HEM-115	10	70	78	22	26	178	199	56
	HEM-150	12	74	84	22	31	188	214	56
	HEM-200	12	76	85	22	31	194	216	56

**NOTE:** 1. All dimensions are from the surfaces of all tubes, couplings and elbows.  
 2. Clearances B, C and D can be reduced by 50% after 25' (7.5 m) of tubing downstream from where the burner and burner tube connect.

**FIGURE 10: 2-FOOT DECO GRILLE AND PROTECTIVE GRILLE**

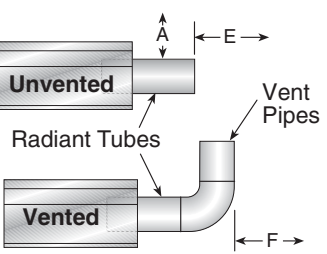
	Model	(inches)				(centimeters)			
		A	B	C	D	A	B	C	D
	HEM-80	6	38	66	38	16	97	168	97
	HEM-115	6	46	77	46	16	117	196	117
	HEM-150	6	50	80	50	16	127	204	127
	HEM-200	8	52	96	52	21	133	244	133

**FIGURE 11: LOWER CLEARANCE SHIELD\***

	Model	(inches)				(centimeters)			
		A	B	C	D	A	B	C	D
	HEM-80	6	40	38	40	16	102	97	102
	HEM-115	6	54	48	54	16	138	122	138
	HEM-150	6	55	50	55	16	140	127	140
	HEM-200	- UNAPPROVED -				- UNAPPROVED -			

\*When installed in the first 10' (3 m).

**FIGURE 12: VENTING**

	Model	(inches)			(centimeters)		
		A	E	F	A	E	F
	HEM-80	20	24	18	51	61	46
	HEM-115	20	24	18	51	61	46
	HEM-150	20	30	18	51	77	46
	HEM-200	20	30	18	51	77	46

## SECTION 4: NATIONAL STANDARDS AND APPLICABLE CODES

### 4.1 Gas Codes

The type of gas appearing on the nameplate must be the type of gas used. Installation must comply with national and local codes and requirements of the local gas company.

United States: Refer to National Fuel Gas Code NFPA 54/ANSI Z223.1 - latest revision.

Canada: Refer to Natural Gas and Propane Installation Code CSA B149.1 - latest revision.

### 4.2 Aircraft Hangars

Installation in aircraft hangars must be in accordance with the following codes:

United States: Refer to Standard for Aircraft Hangars, NFPA 409 - latest revision.

Canada: Refer to Natural Gas and Propane Installation Code CSA B149.1 - latest revision.

In aircraft storage and servicing areas, heaters shall be installed at least 10' (3 m) above the upper surface of wings or of engine enclosures of the highest aircraft which may be housed in the hangar. The measurement shall be made from the wing or engine enclosure (whichever is higher from the floor) to the bottom of the heater.

- In shops, offices and other sections of aircraft hangars communicating with aircraft storage or servicing areas, heaters shall be installed not less than 8' (2.4 m) above the floor.
- Suspended or elevated heaters shall be so located in all spaces of aircraft hangars that they shall not be subject to injury by aircraft, cranes, movable scaffolding or other objects. Provisions shall be made to assure accessibility to suspended heaters for recurrent maintenance purposes.

### 4.3 Public Garages

Installation in garages must be in accordance with the following codes:

United States: Refer to Standard for Parking Structures NFPA 88A - latest revision or the Code for Motor Fuel Dispensing Facilities and Repair Garages, NFPA 30A - latest revision.  
Canada: Refer to Natural Gas and Propane Installation Code CSA B149.1 - latest revision.

- Heaters must not be installed less than 8' (2.4 m) above the floor. Minimum clearances to combustibles must be maintained from vehicles parked below the heater.
- When installed over hoists, minimum clearances to combustibles must be maintained from the upper most point of objects on the hoist.

### 4.4 Electrical

The heater must be electrically grounded in accordance with the following codes:

United States: Refer to National Electrical Code®, NFPA 70 - latest revision. Wiring must conform to the most current National Electrical Code®, local ordinances and any special diagrams furnished.

Canada: Refer to Canadian Electrical Code, CSA C22.1 Part 1 - latest revision.

### 4.5 Venting

The venting must be installed in accordance with the requirements within this manual and the following codes:

United States: Refer to National Fuel Gas Code NFPA 54/ANSI Z223.1 - latest revision.

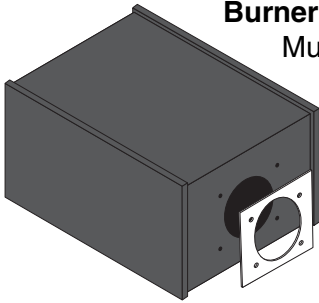
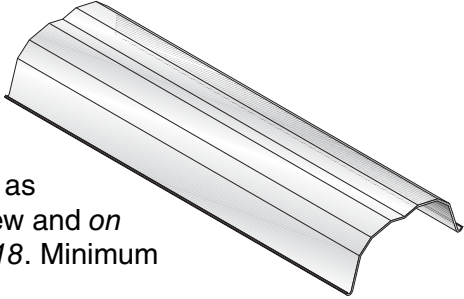
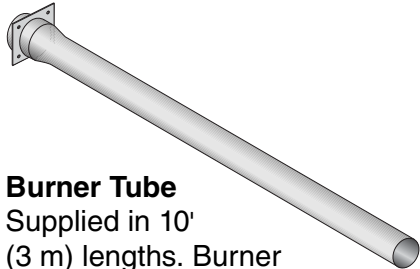

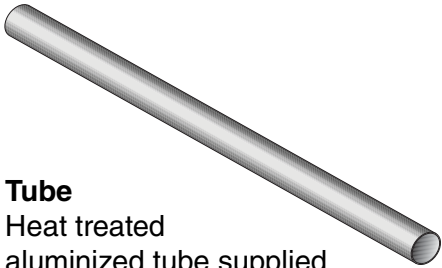
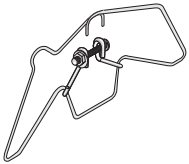
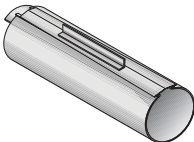
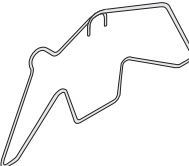
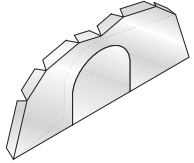
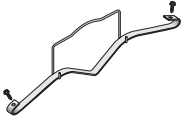
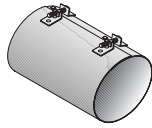
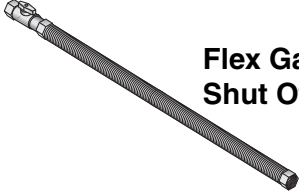
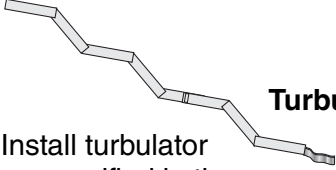
Canada: Refer to Natural Gas and Propane Installation Code CSA B149.1 - latest revision.

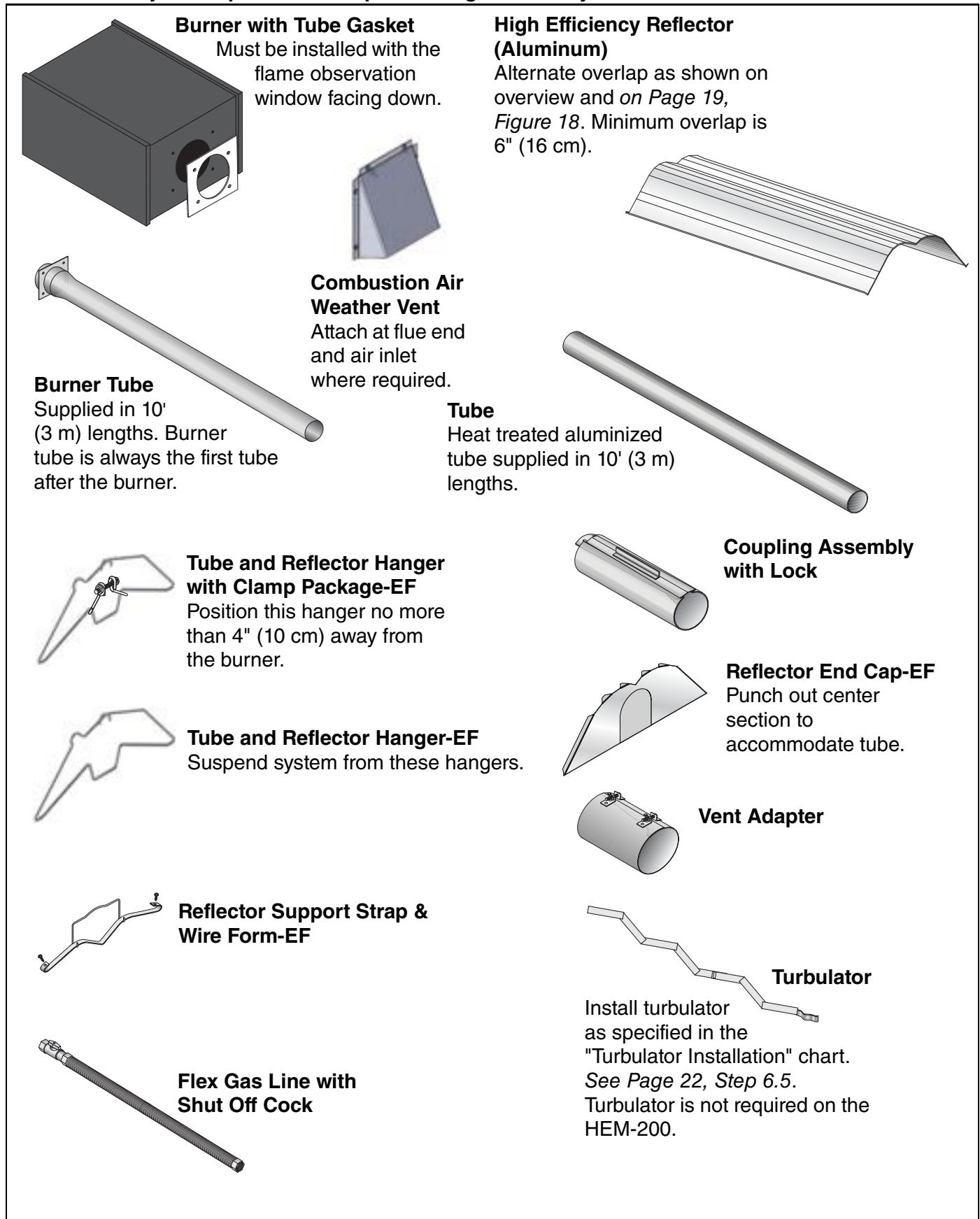
### 4.6 High Altitude

These heaters are approved for installations up to 2000' (610 m)(US), 4500' (1370 m)(Canada) without modification. Consult factory if US installation is above 2000' (610 m) or Canadian installation is above 4500' (1370 m).

**SECTION 5: MAJOR COMPONENTS**

**FIGURE 13: Major Component Descriptions - Standard Reflector**

 <p><b>Burner with Tube Gasket</b> Must be installed with the flame observation window facing down.</p>	<p><b>Standard Reflector (Aluminum or Stainless Steel)</b></p>	
 <p><b>Burner Tube</b> Supplied in 10' (3 m) lengths. Burner tube is always the first tube after the burner.</p>	 <p><b>Combustion Air Weather Vent</b> Attach at flue end and air inlet where required.</p>	 <p><b>Tube</b> Heat treated aluminized tube supplied in 10' (3 m) lengths.</p>
 <p><b>Tube and Reflector Hanger with Clamp Package</b> Position this hanger no more than 4" (10 cm) away from the burner.</p>	 <p><b>Coupling Assembly with Lock</b></p>	<p><b>Coupling Assembly with Lock</b></p>
 <p><b>Tube and Reflector Hanger</b> Suspend system from these hangers.</p>	 <p><b>Reflector End Cap</b> Punch out center section to accommodate tube.</p>	<p><b>Reflector End Cap</b> Punch out center section to accommodate tube.</p>
 <p><b>Reflector Support Strap &amp; Wire Form</b></p>	 <p><b>Vent Adapter</b></p>	<p><b>Vent Adapter</b></p>
 <p><b>Flex Gas Line with Shut Off Cock</b></p>	 <p><b>Turbulator</b></p>	<p><b>Turbulator</b> Install turbulator as specified in the "Turbulator Installation" chart. See Page 22, Step 6.5. Turbulator is not required on the HEM-200.</p>

**FIGURE 14: Major Component Descriptions - High Efficiency Reflector**



5.1 Standard Parts List

Table 1: Contents of the Burner Carton

Part No.	Description	HEM-80	HEM-115	HEM-150	HEM-200
039XXXXX	Burner Assembly (Rate and Fuel Varies)	1	1	1	1
02568200	Gasket (Burner to Burner Tube)	1	1	1	1
138100NA	Installation, Operation and Service Manual	1	1	1	1
03700009	Combustion Air Weather Vent	1	1	1	1
94273914	Hex Head Bolts 5/16" - 18 Rolok	4	4	4	4
96411600	Split Lock washer	4	4	4	4
91221100	Pipe Nipple (Galvanized) 1/2" NPT x 4"	1	1	1	1
91412204*	3/4" x 36" Vinyl Coated Flex Stainless Steel Gas Line (US Models Only)	1	1	1	1
03051501	Turbulator Adapter	1	1	1	-
03051502	Turbulator Aluminized Steel	3	3	1	-
91317310	Wire Terminal Receptacle .187 x .032	8	8	8	8
91309701	Cable Grommet - Liquid Tight	2	2	2	2

\*Canadian Models: Rubber (Type 1) Gas Hoses available as an accessory. See Page 43, Section 9.

Table 2: Contents of Standard Core and Extension Packages

Part No.	Description	Core Packages								Extension Packages							
		Aluminized with Aluminum Reflector				Aluminized with Stainless Steel Reflector				Aluminized with Aluminum Reflector				Aluminized with Stainless Steel Reflector			
		10' (3 m)	20' (6 m)	30' (9 m)	40' (12 m)	10' (3 m)	20' (6 m)	30' (9 m)	40' (12 m)	10' (3 m)	20' (6 m)	30' (9 m)	40' (12 m)	10' (3 m)	20' (6 m)	30' (9 m)	40' (12 m)
91409408	Tube, HT Aluminized, 10' (3 m)	-	1	2	3	-	1	2	3	1	2	3	4	1	2	3	4
03051101	Burner Tube, ALUMI-THERM® Steel, 10' (3 m)	-	-	1	1	-	-	-	-	-	-	-	-	-	-	-	-
03051102	Burner Tube, ALUMI-THERM® Steel, 10' (3 m)	-	-	-	-	-	-	1	1	-	-	-	-	-	-	-	-
03051601	Burner Tube, HT ALUMI-THERM® Steel, 10' (3 m)	1	1	-	-	-	-	-	-	-	-	-	-	-	-	-	-
03051602	Burner Tube, HT ALUMI-THERM® Steel - HE, 10' (3m)	-	-	-	-	1	1	-	-	-	-	-	-	-	-	-	-
01312700	Coupling Assembly	-	1	2	3	-	1	2	3	1	2	3	4	1	2	3	4
02750303	Standard Reflector, 8' (3.5 m)	2	3	4	6	-	-	-	-	2	3	4	6	-	-	-	-
027503SS*	Stainless Steel Reflector, 8' (3.5 m)	-	-	-	-	2	3	4	6	-	-	-	-	2	3	4	6
02750800	End Cap	2	2	2	2	-	-	-	-	-	-	-	-	-	-	-	-
027508SH*	Stainless Steel End Cap with Hole	-	-	-	-	2	2	2	2	-	-	-	-	-	-	-	-
03090100	Tube and Reflector Hanger	2	3	4	5	2	3	4	5	1	2	3	4	1	2	3	4
91907302	S-Hook	2	3	4	5	2	3	4	5	1	2	3	4	1	2	3	4
03050010	Reflector Support Package (Strap, Wire Form, Screws)	1	2	3	5	2	4	5	7	2	3	4	6	2	3	4	6
91107720	U-Clip Package	1	1	1	1	1	1	1	1	1	1	1	1	1	1	1	1
90502700	Vent Adapter	1	1	1	1	1	1	1	1	-	-	-	-	-	-	-	-
01318901	Tube Clamp Package	1	1	1	1	2	2	2	2	-	-	-	-	-	-	-	-
<b>Part Number</b>		<b>CP10ALUM</b>	<b>CP20ALUM</b>	<b>CP30ALUM</b>	<b>CP40ALUM</b>	<b>CP10ALUMSS</b>	<b>CP20ALUMSS</b>	<b>CP30ALUMSS</b>	<b>CP40ALUMSS</b>	<b>EXP10ALUM</b>	<b>EXP20ALUM</b>	<b>EXP30ALUM</b>	<b>EXP40ALUM</b>	<b>EXP10ALUMSS</b>	<b>EXP20ALUMSS</b>	<b>EXP30ALUMSS</b>	<b>EXP40ALUMSS</b>

\* Optional with the aluminized core package.

**Table 3: Contents of High Efficiency Core and Extension Packages**

Part No.	Description	Core Packages				Extension Packages			
		Aluminized				Aluminized			
		10' (3m)	20' (6m)	30' (9m)	40' (12m)	10' (3m)	20' (6m)	30' (9m)	40' (12m)
91409408	Tube, HT Aluminized, 10' (3 m)	-	1	2	3	1	2	3	4
03051101	Burner Tube, ALUMI-THERM® Steel, 10' (3 m)	-	-	1	1	-	-	-	-
03051601	Burner Tube, HT ALUMI-THERM® Steel, 10' (3 m)	1	1	-	-	-	-	-	-
01312700	Coupling Assembly	-	1	2	3	1	2	3	4
02750313	High Efficiency Reflector, 8' (3.5 m)	2	3	4	6	2	3	4	6
02750802	High Efficiency End Cap	2	2	2	2	-	-	-	-
03090102	Tube and Reflector Hanger	2	3	4	5	1	2	3	4
91907302	S-Hook	2	3	4	5	1	2	3	4
03050012	Reflector Support Package (Strap, Wire Form, Screws)	1	2	3	5	2	3	4	6
91107720	U-Clip Package	1	1	1	1	1	1	1	1
90502701	Vent Adapter	1	1	1	1	-	-	-	-
01318902	Tube Clamp Package - EF	1	1	1	1	-	-	-	-
	<b>Part Number</b>	CP10ALUMEF	CP20ALUMEF	CP30ALUMEF	CP40ALUMEF	EXP10ALUMEF	EXP20ALUMEF	EXP30ALUMEF	EXP40ALUMEF

**NOTE:** High efficiency core and extension packages are available with aluminum reflectors only. High efficiency reflectors should NOT be used in applications exposed to wind.

**Table 4: Component Package Guide**

Model	Tubing Length	Standard Core Packages	
	Minimum	Aluminized	Stainless Steel
HEM-80	20' (6m)	CP20ALUM	CP20ALUMSS
HEM-115	30' (9m)	CP30ALUM	CP30ALUMSS
HEM-150	40' (12m)	CP40ALUM	CP40ALUMSS
HEM-200	50' (15m)	CP30ALUM + EXP20ALUM	CP30ALUMSS+ EXP20ALUMSS

**Table 5: Component Package Guide**

Model	Tubing Length	High Efficiency Core Packages
	Minimum	Aluminized
HEM-80	20' (6m)	CP20ALUMEF
HEM-115	30' (9m)	CP30ALUMEF
HEM-150	40' (12m)	CP40ALUMEF
HEM-200	50' (15m)	CP30ALUMEF + EXP20ALUMEF

Although not recommended, additional tube lengths may be added to the heater. Tubing must be aluminized (heat-treated), or porcelain coated. Additional tube lengths beyond the specified minimum tubing length are considered vent pipe for length determination. Maximum vent length allowed is 45' (13.7 m) total.

**SECTION 6: HEATER INSTALLATION****! WARNING****Severe Injury Hazard**

**Secure burner to burner tube with nuts and lockwashers.**

**Hang heater with materials with a minimum working load of 75 lbs (33 kg).**

**Failure to follow these instructions can result in death, injury or property damage.**

Expansion and contraction of the tube dictates that the minimum suspension lengths in the table on Page 16, Figure 15 be maintained.

**! WARNING****Cut/Pinch Hazard**

**Wear protective gear during installation, operation and service.**

**Edges are sharp.**

**Failure to follow these instructions can result in injury.**

To ensure your safety, and comply with the terms of the warranty, all units must be installed in accordance with these instructions.

The gas or the electrical supply lines must not be used to support the heater.

Do not locate the gas or electric supply lines directly over the path of the flue products from the heater.

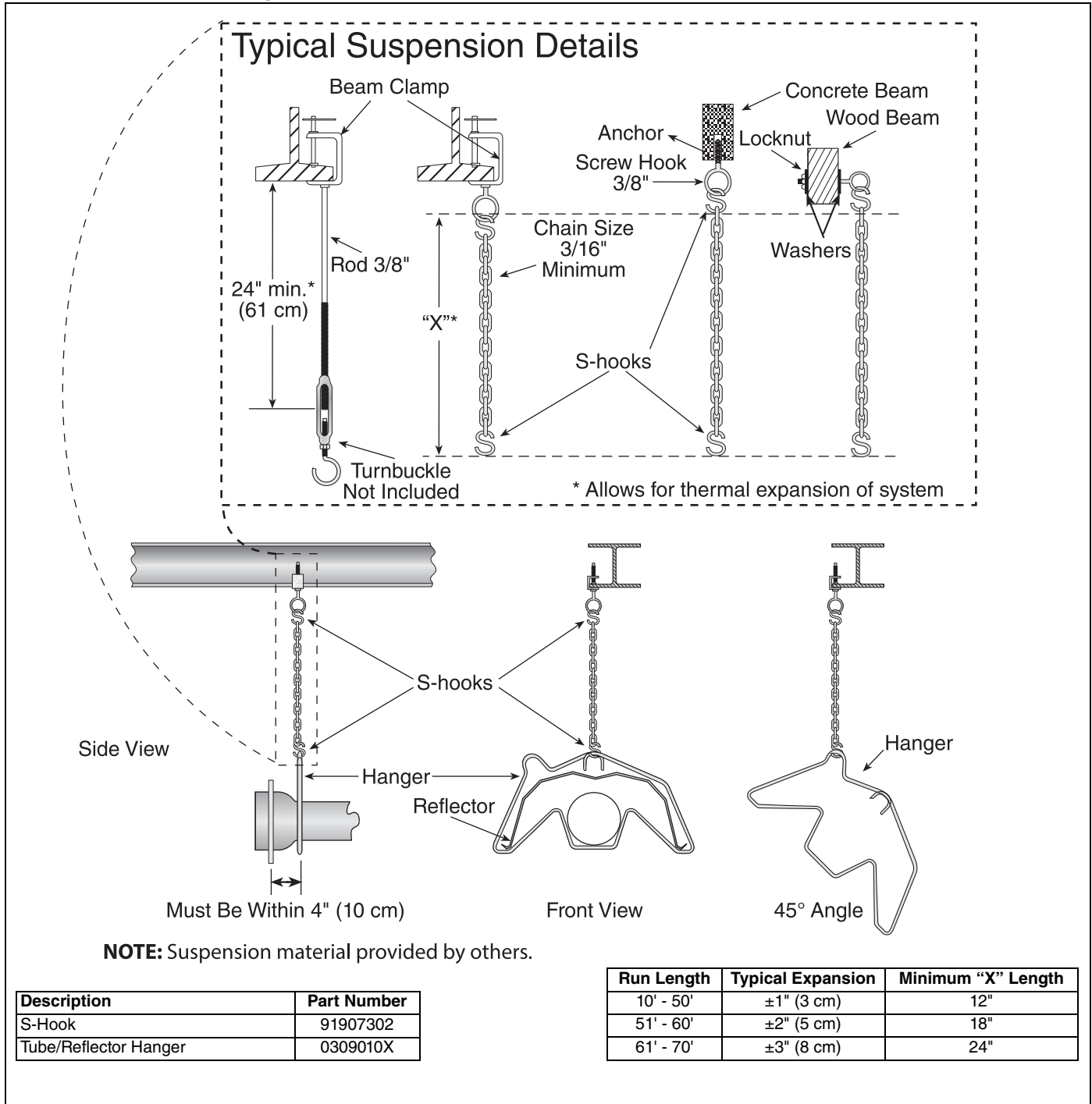
The heater must be installed in a location that it is readily accessible for servicing.

The heater must be installed in accordance with clearances to combustibles as indicated on the heater and in this instruction manual.

The gas inlet pressure must be maintained as indicated on the rating plate.

Typical installation configurations are shown on Page 16, Figure 15.

**FIGURE 15: Critical Hanger Placement**



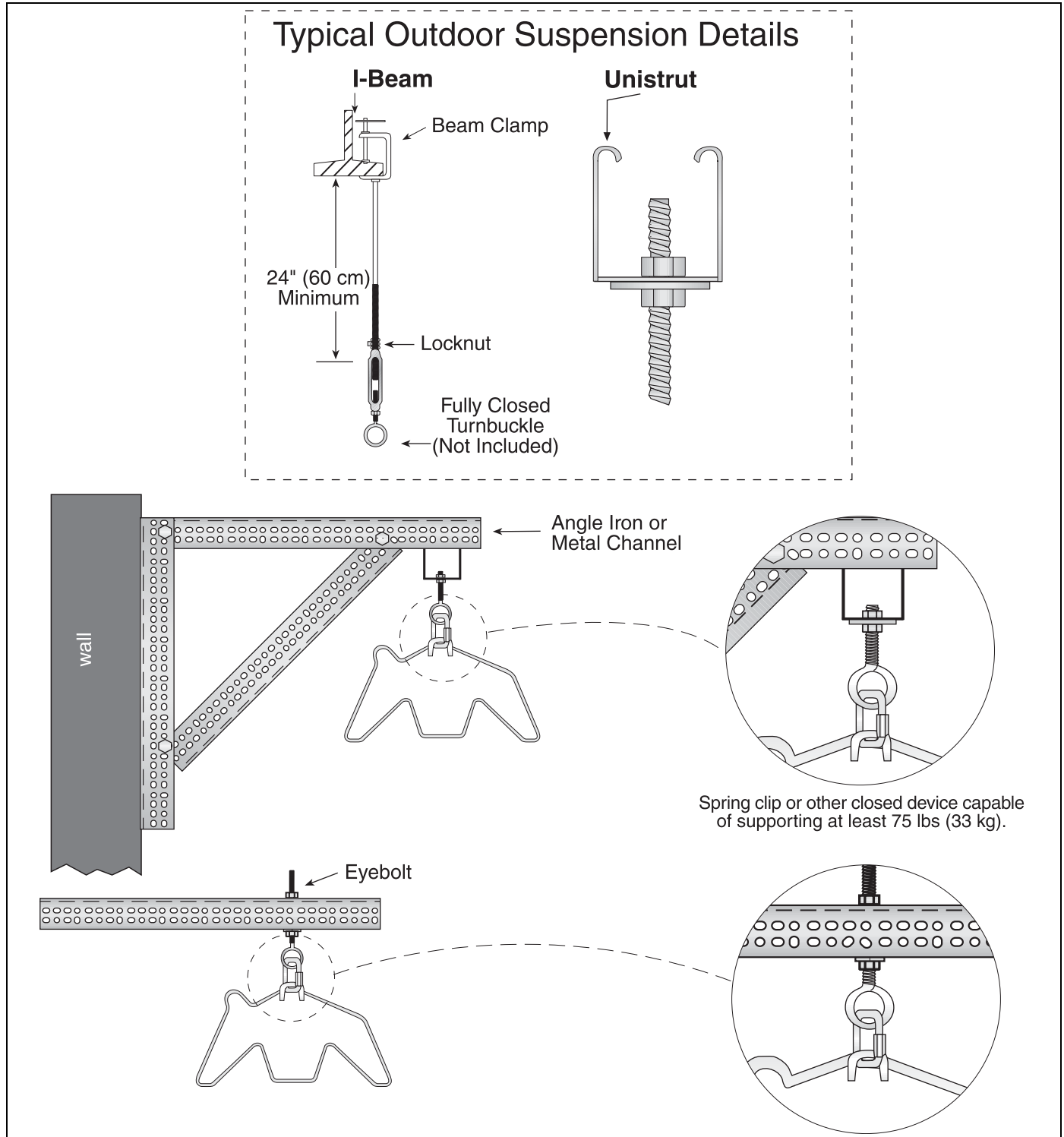
## 6.1 Outdoor Mounting

The heater is meant for stationary mounting in all situations and should not be suspended from any structure which may become mobile or from any organic structures such as trees. Clearances to combustibles must be maintained in all cases; do not install heaters in a location such as a parking area, where a vehicle with a painted or non-metallic upper surface,

may be parked within the clearances to combustibles. See Page 17, Figure 16.

The bottom of the combustion air inlet shall not be less than 12" (30 cm) above a surface which could support snow, ice, or debris.

**FIGURE 16: Critical Hanger Placement (Outdoor Installation)**



**NOTE:** High efficiency reflectors should NOT be used in applications exposed to wind.

FIGURE 17: Linear Heater Assembly Overview

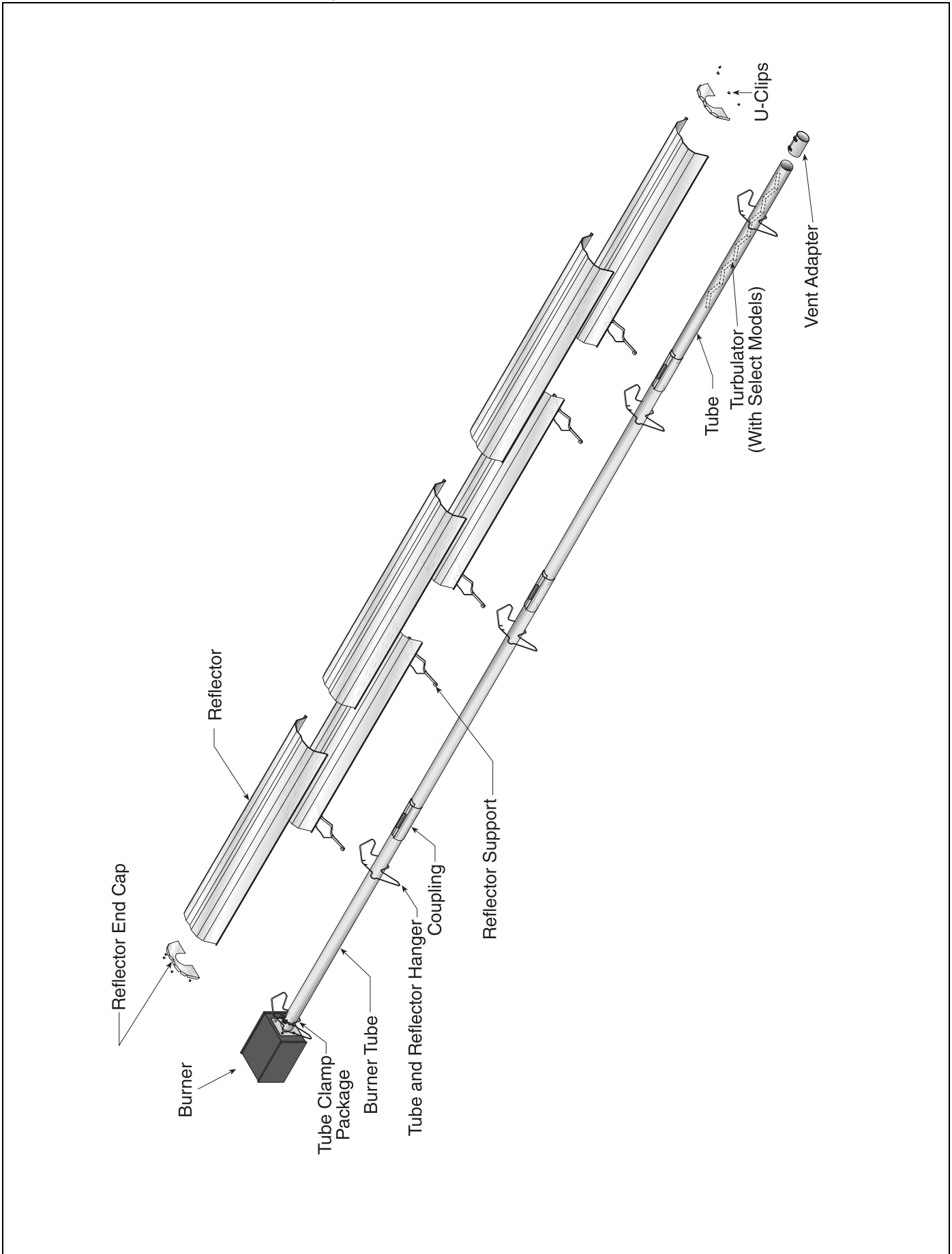
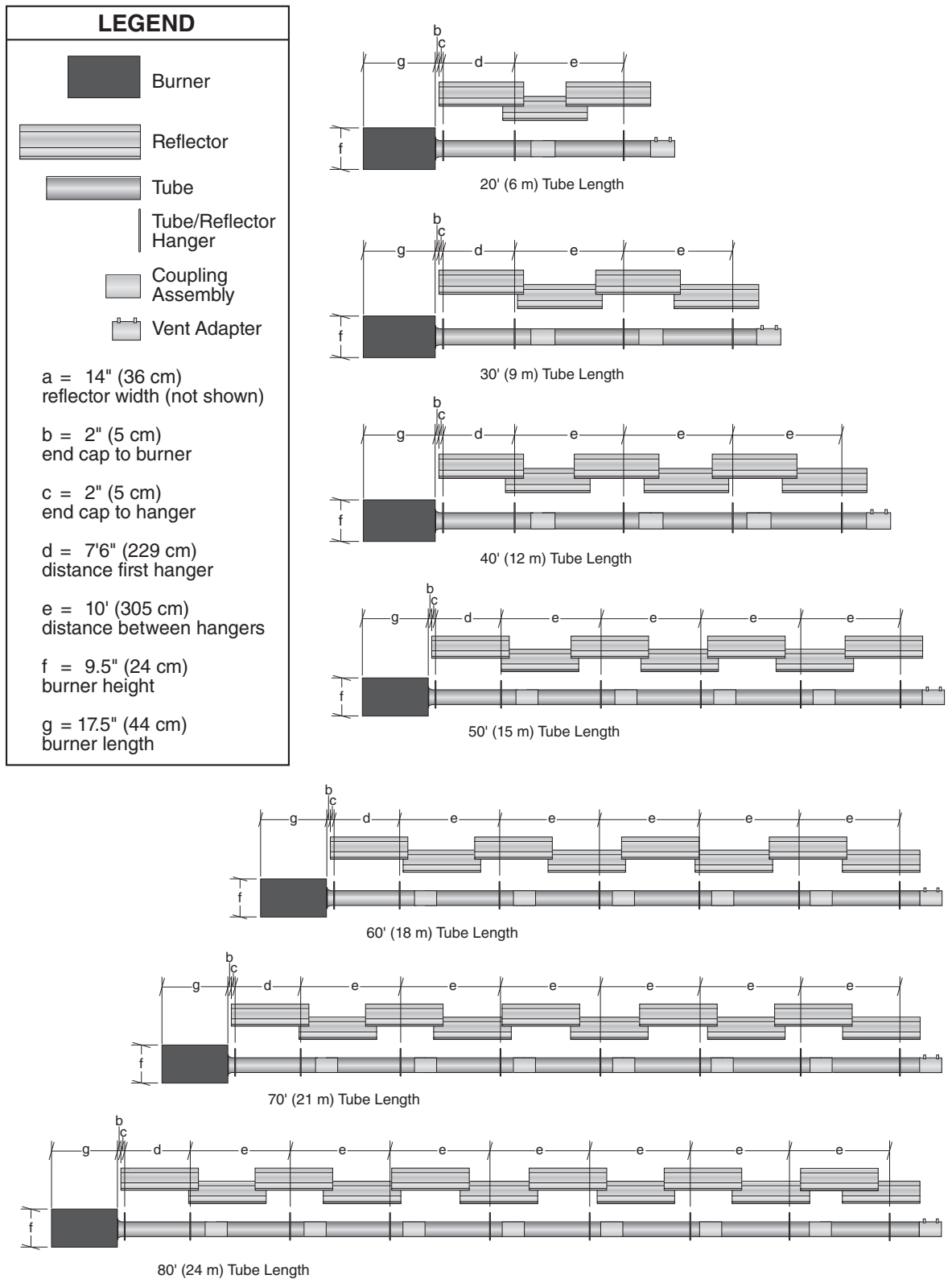


FIGURE 18: Linear Heater Layout Overview





### Step 6.2 Burner Tube Installation

**NOTE:**  
 Tubing requires a downward slope of 1/2" (1.3 cm) per 20' (6 m) away from burner.

The diagram illustrates the installation of a burner tube. A burner tube is suspended from a hanger, which is attached to an S-hook. The hanger is mounted to a reflector. The burner tube is positioned at a distance of 7' 6" ± 1' (229 cm ± 25 cm) from the burner. A circular inset provides a detailed view of the burner tube's connection to the hanger, showing that the offset mounting hole must be positioned at the top and the weld seam must be at the bottom of the tube.

Description	Part Number
Burner Tube	03051XXX
S-Hook	91907302
Tube/Reflector Hanger	0309010X

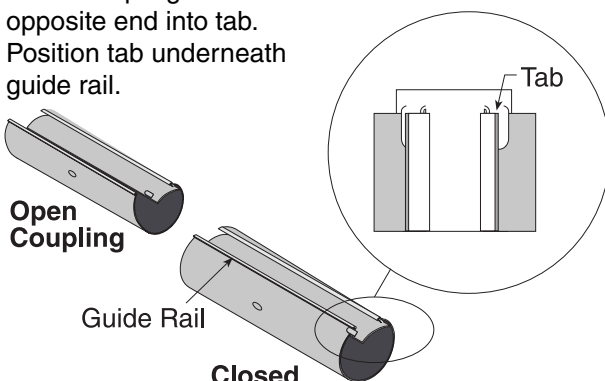
### Step 6.3 Tube Clamp Package Installation

Description	Part Number
Tube Clamp Package	0131890X

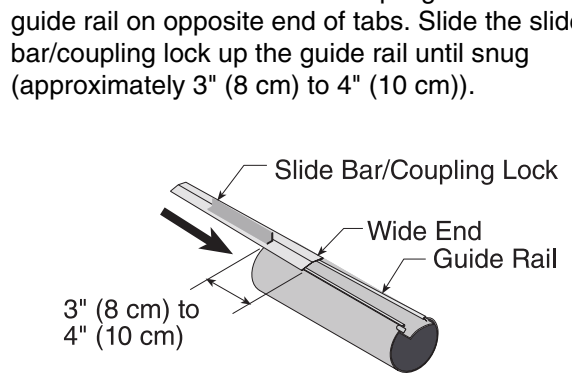
The diagram shows the installation of a tube clamp package. A tube clamp is attached to a burner tube using a bolt, flat washer, and nut. The nut is tightened to a torque of 120 in/lb (13.56 Nm). A circular inset provides a detailed view of the clamp assembly, showing the tube clamp, bolt, flat washer, and nut. The clamp is attached to the burner tube, and a chain is used to suspend the burner tube from the reflector.

**Step 6.4 Coupling and Tube Assembly**

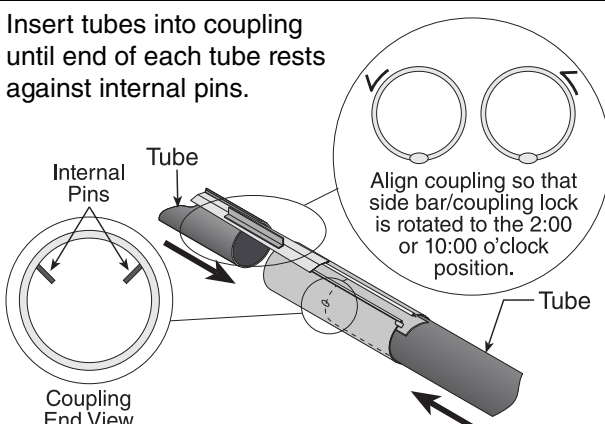
**A** Close coupling and slide opposite end into tab. Position tab underneath guide rail.



**B** Insert wide end of slide bar/coupling lock into guide rail on opposite end of tabs. Slide the slide bar/coupling lock up the guide rail until snug (approximately 3" (8 cm) to 4" (10 cm)).

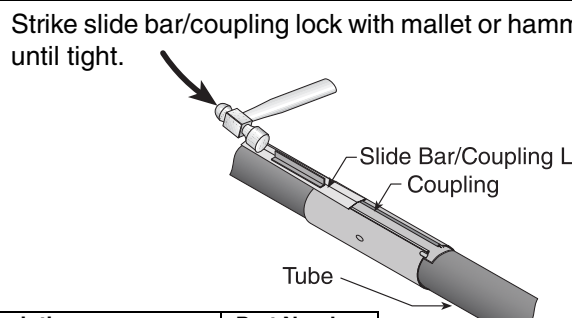


**C** Insert tubes into coupling until end of each tube rests against internal pins.



Align coupling so that side bar/coupling lock is rotated to the 2:00 or 10:00 o'clock position.

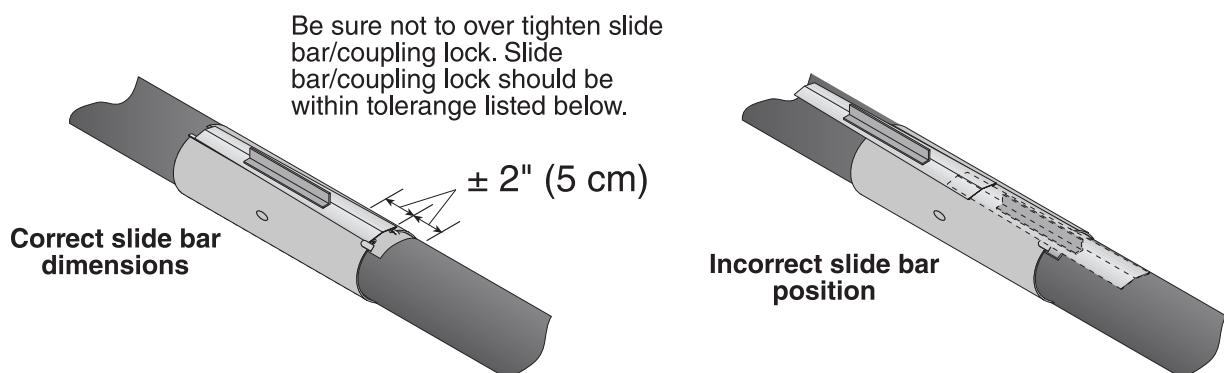
**D** Strike slide bar/coupling lock with mallet or hammer until tight.



Description	Part Number
Coupling	01329600
Slide Bar/Coupling Lock	01329700
Tube	91409XXX

**Step 6.4.1 Coupling and Tube Assembly (Continued)**

Tighten slide bar as shown below.



- Repeat Step 6.4 A - D until all tubes are assembled. See Page 22, Section 6.4.2.

**Step 6.4.2 Coupling and Tube Assembly (Continued)**

The diagram illustrates the assembly of a long tube with a coupling. The coupling length is specified as  $7' 6'' \pm 1'$  ( $2.3 \text{ m} \pm .25 \text{ m}$ ). The distance between coupling points is  $10' \pm 1'$  ( $3 \text{ m} \pm .25 \text{ m}$ ). The total overall tube length is indicated by a dimension line.

Model	Tube Length Minimum
HEM-80	20' (6 m)
HEM-115	30' (9 m)
HEM-150	40' (12 m)
HEM-200	50' (15 m)

**Step 6.5 Turbulator Installation**

The diagram shows a turbulator section being installed on a tube. A turbulator adapter is used to secure the turbulator section. A tab is folded around the outside of the tube to hold the turbulator in place. A pull string is attached to the end of the tube. A circular inset shows a close-up of the turbulator section being twisted.

Install turbulator as specified in the "Turbulator Installation" chart below. Turbulator is not required on the HEM-200.

Turbulator Installation	
HEM-80	2nd 10' Section
HEM-115	3rd 10' Section
HEM-150	4th 10' Section
HEM-200	N/A

Description	Part Number
Turbulator Adapter	03051501
Turbulator Section	03051502
Tube	91409XXX

## 6.6 Reflector Installation

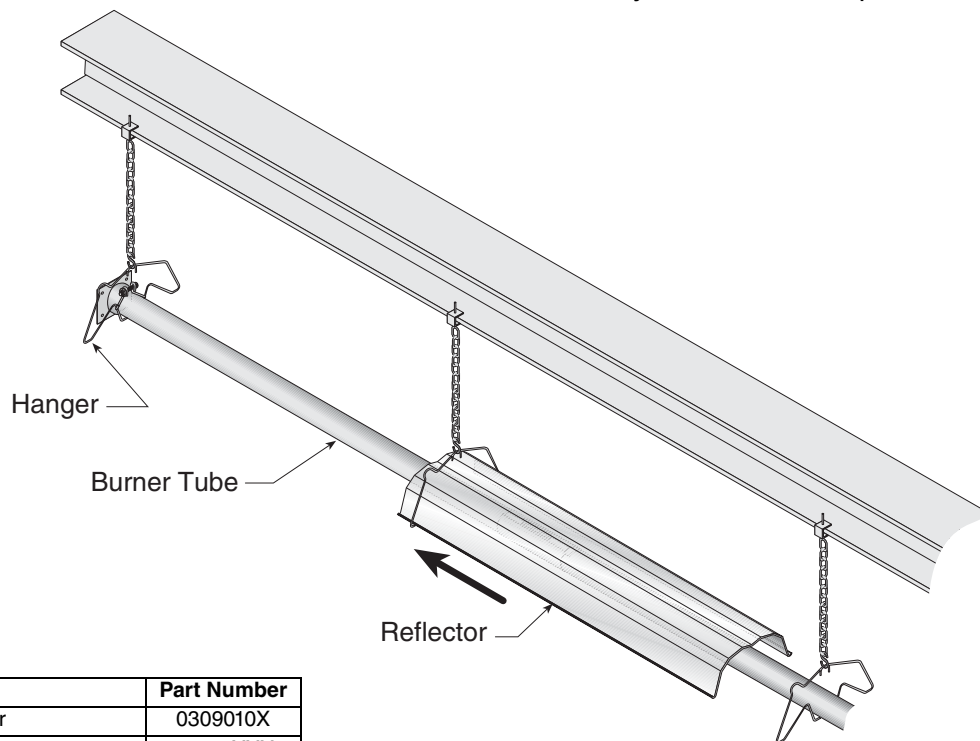
**⚠ WARNING****Fire Hazard**

Support reflector with reflector hanger and support strap.

Reflector must not touch tube.

Failure to follow these instructions can result in death, injury or property damage.

**NOTE:** All tube surfaces must be covered by a reflector, except for a U-Tube.



Description	Part Number
Tube/Reflector Hanger	0309010X
Burner Tube	03051XXX
Reflector-96" (244 cm)	027503XX

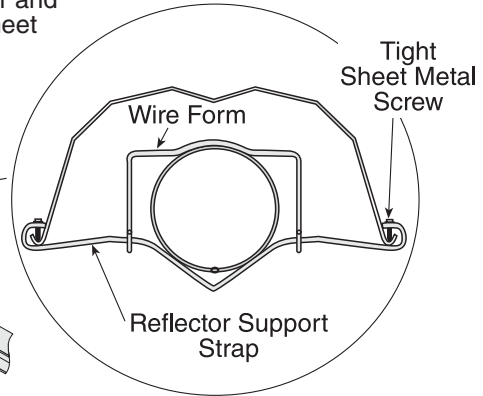
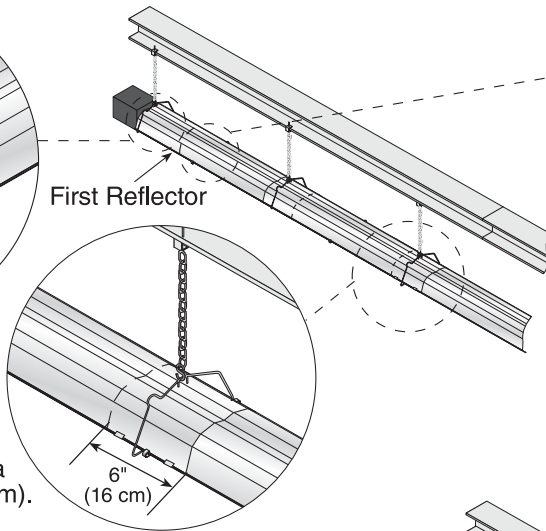
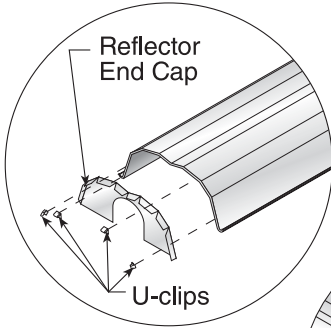
### Step 6.6.1 Reflector, U-Clip and Reflector Support Installation

The pictorial drawings of the heater construction in *Section 6* are schematic only and provide a general guideline of where hangers, reflector supports and U-clips are to be installed.

To ensure proper expansion and contraction movement of the reflectors, a combination of U-clips and reflector supports are used. The positioning of

reflector supports and U-clips depends on the individual installation. Use either pop rivets or sheet metal screws instead of u-clips when installing end caps and joint pieces in areas where impact and high wind may be a factor. The following rules must be observed.

1. Slide first reflector after burner a minimum 2" (4 cm) through first hanger and ensure reflector end cap is securely fastened via U-clips, pop rivets, or sheet metal screws. Position reflector support with tight screws in middle of first reflector.

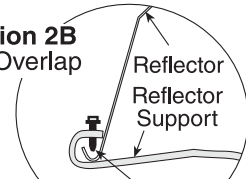


Overlap must be a minimum of 6" (16 cm).

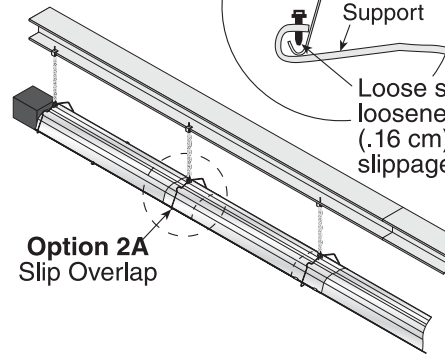
2. The overlap at the first and second reflector is a **slip overlap**. Thereafter, every third reflector joint is a slip overlap. A slip overlap is achieved by either:

- a.) both reflectors lay inside a hanger.
- (No reflector support needed.)
- b.) using a reflector support with loose screws at the reflector overlap.

**Option 2B**  
Slip Overlap



Loose screws loosened 1/16" (.16 cm) to allow slippage.

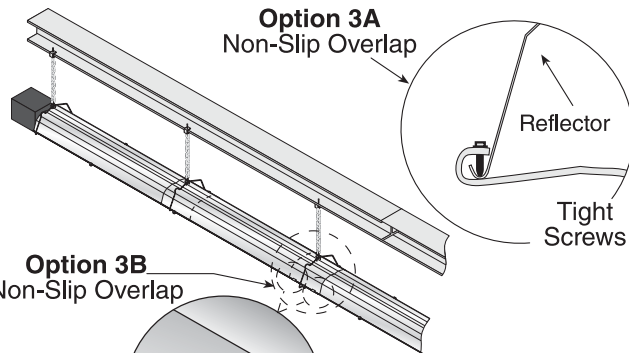


3. The remaining reflector overlaps require a **non-slip overlap** connection. To affix the reflectors together in a non-slip overlap either:

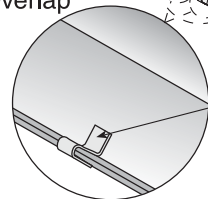
- a.) use reflector support and tight screws.
- b.) if both reflectors lay inside a hanger, u-clips or sheet metal screws may be used.

This section of three reflectors joined together must be affixed to the tube with at least one reflector support with tight screws.

**Option 3A**  
Non-Slip Overlap



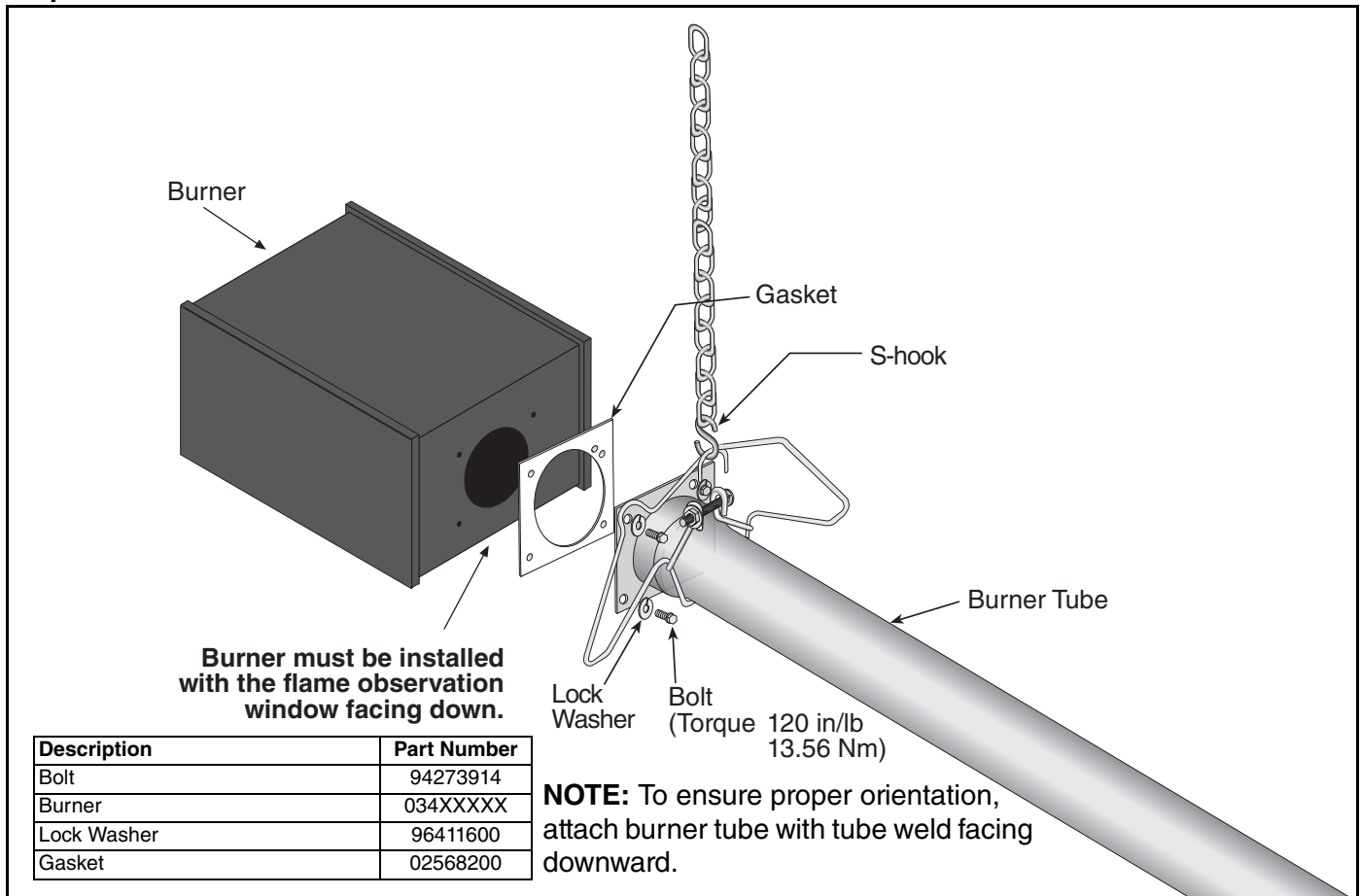
**Option 3B**  
Non-Slip Overlap



**NOTE:** High efficiency reflectors should NOT be used in applications exposed to wind.

Description	Part Number
<b>Reflector Support Package</b>	<b>0305001X</b>
Wire Form	91908004
Reflector Support Strap	0305000X
Screw #8 x 3/4	94320812
U-Clip Package	91107720
Reflector End Cap	027508XX

## Step 6.7 Burner Installation



**SECTION 7: OPTIONAL HEATER ACCESSORIES****⚠ WARNING****Cut/Pinch Hazard**

**Wear protective gear during installation, operation and service.**

**Edges are sharp.**

**Failure to follow these instructions can result in injury.**

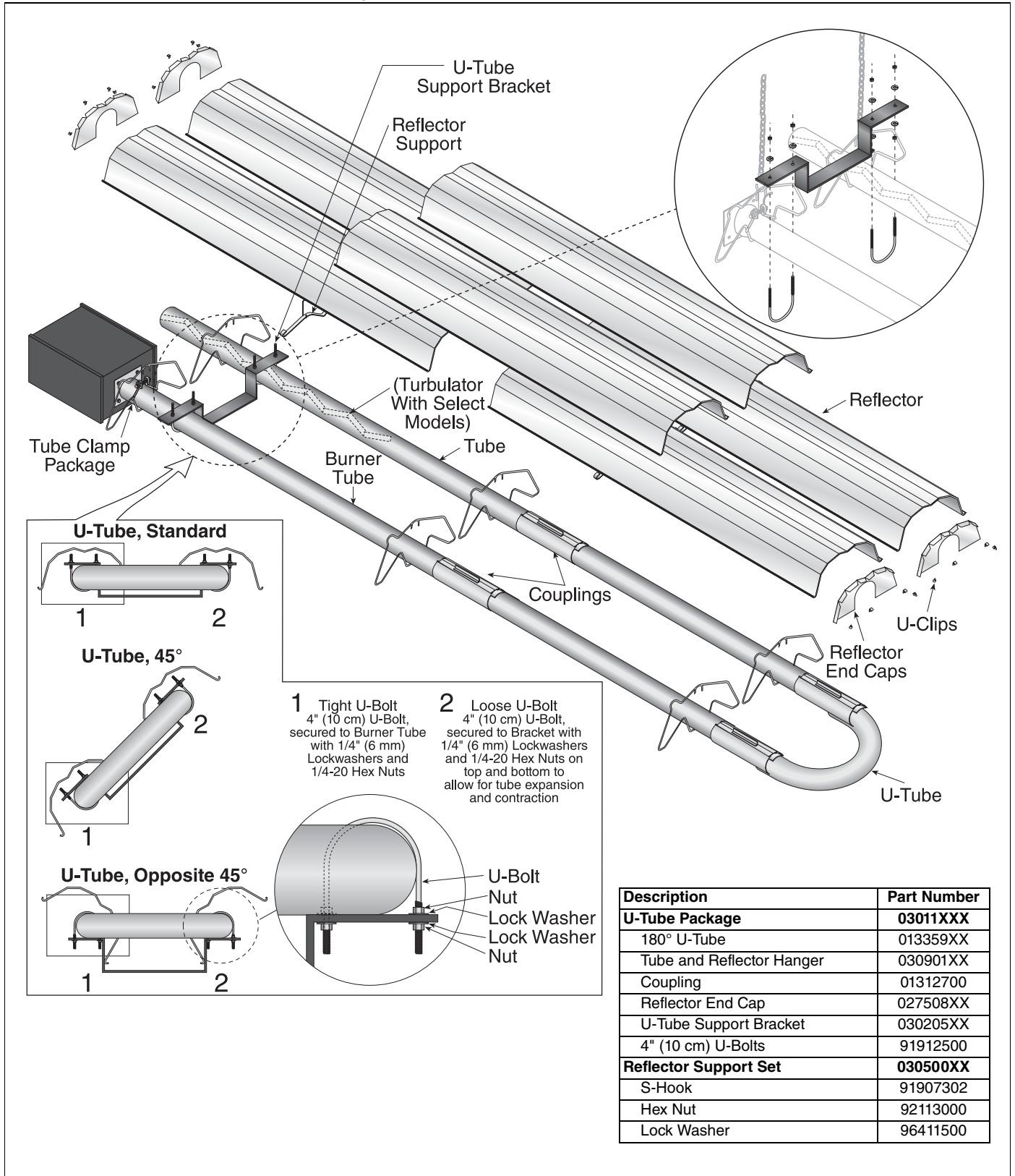
**7.1 U-Tube Configuration**

Heaters are approved for optional U-Tube configurations.

The U-Tube may be installed in either a standard horizontal position, a 45° position or in an opposite 45° position as shown on *Page 7, Figure 7 through Figure 9*. When using a U-Tube configuration, the following additional rules must be adhered to:

- A minimum of 10' (3 m) on HEM-80 and a minimum of 15' (4.5 m) on HEM-115/150/200 is required between the burner and the U-Tube.
- The correct turbulator (*See Page 22, Figure 6.5*) must be installed in the last standard section of tube.
- The burner must never be operated in a tilted position.
- The heater must be properly supported at all locations. *See Page 28, Figure 20.*








**FIGURE 19: U-Tube Heater Assembly Overview**





**FIGURE 20: U-Tube Heater Layout Overview**

**LEGEND**

-  Burner
-  Reflector
-  Tube 10' (3 m)
-  Tube 5' (1.5 m)\*\*
-  Tube/Reflector Hanger
-  Coupling Assembly
-  U-tube

a = 14" (36 cm)  
reflector width (not shown)

b = 2" (5 cm)  
end cap to burner

c = 2" (5 cm)  
end cap to hanger

d = 7'6" (229 cm)  
distance first hanger

e = 10' (305 cm)  
distance between hangers

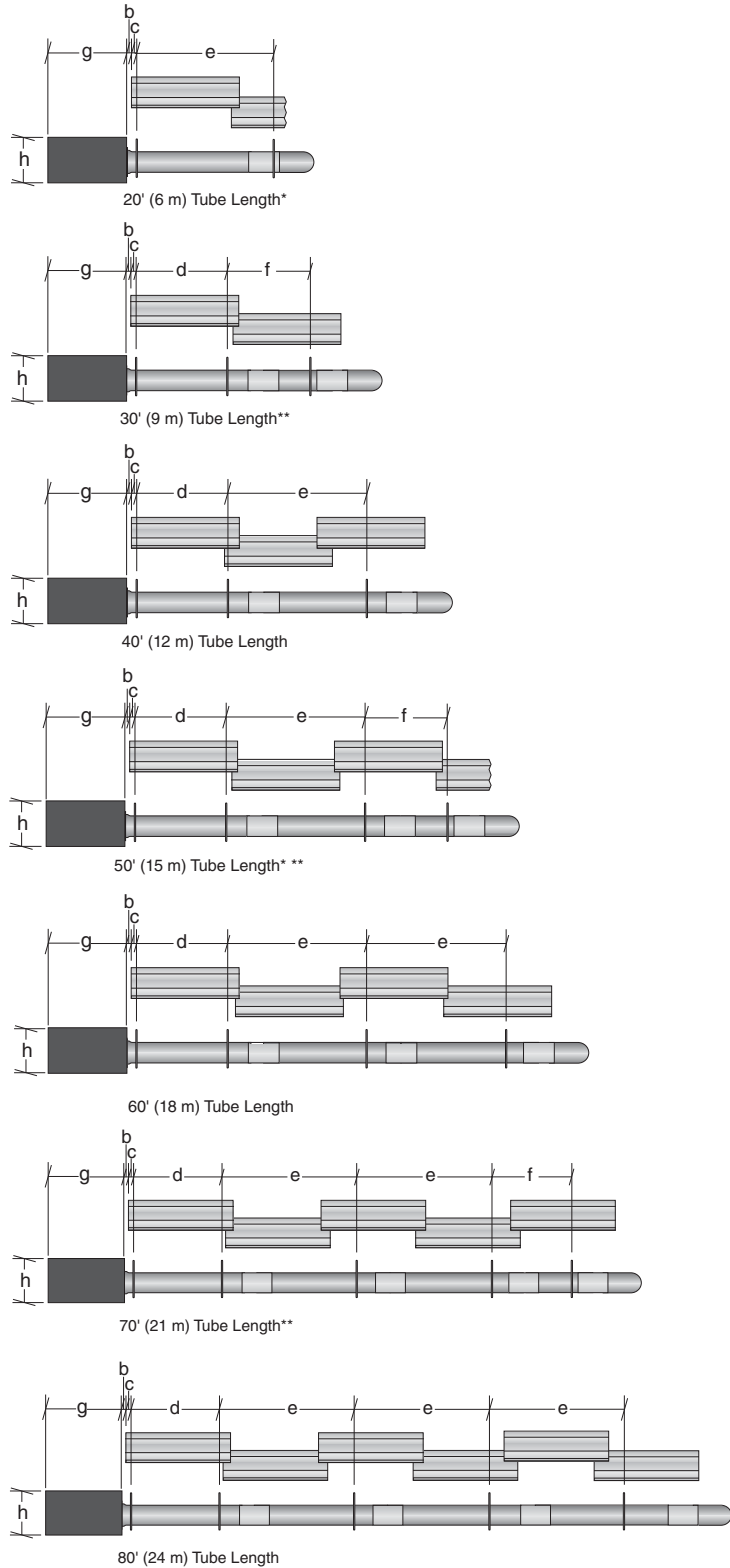
f = 5' (153 cm)  
distance between last full tube hanger and half tube hanger

g = 17.5" (44 cm)  
burner length

h = 9.5" (24 cm)  
burner height

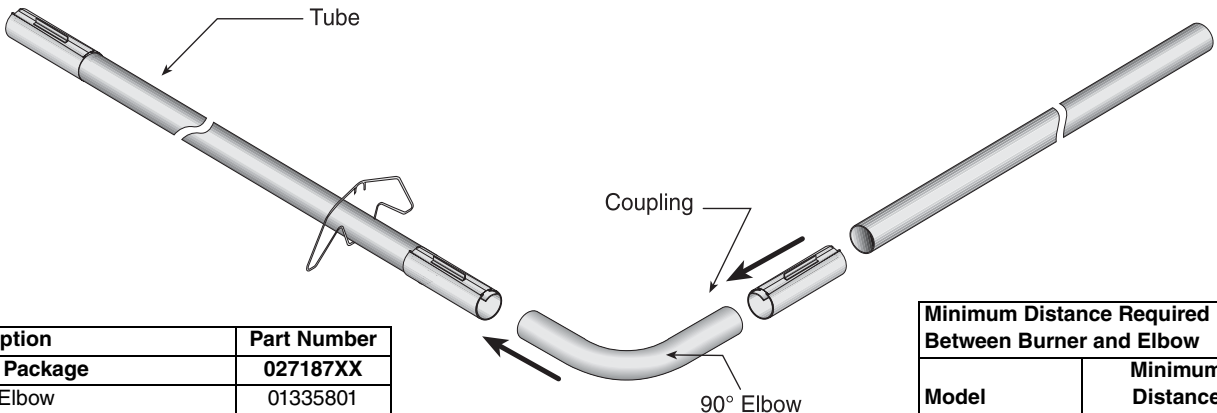
\*Requires the last **reflector** before the u-tube to be cut in half for use on both sides.

\*\*Requires the last **tube** before the u-tube to be cut in half for use on both sides.



## 7.2 Elbow Package Configuration

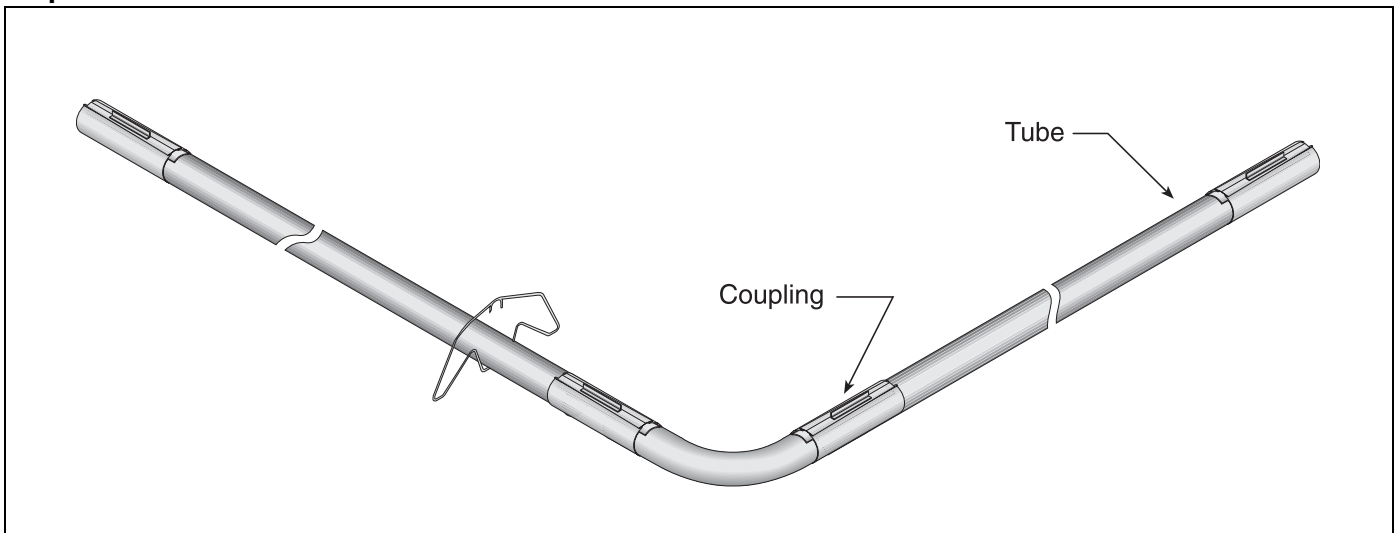
### Step 7.2.1 Elbow Installation



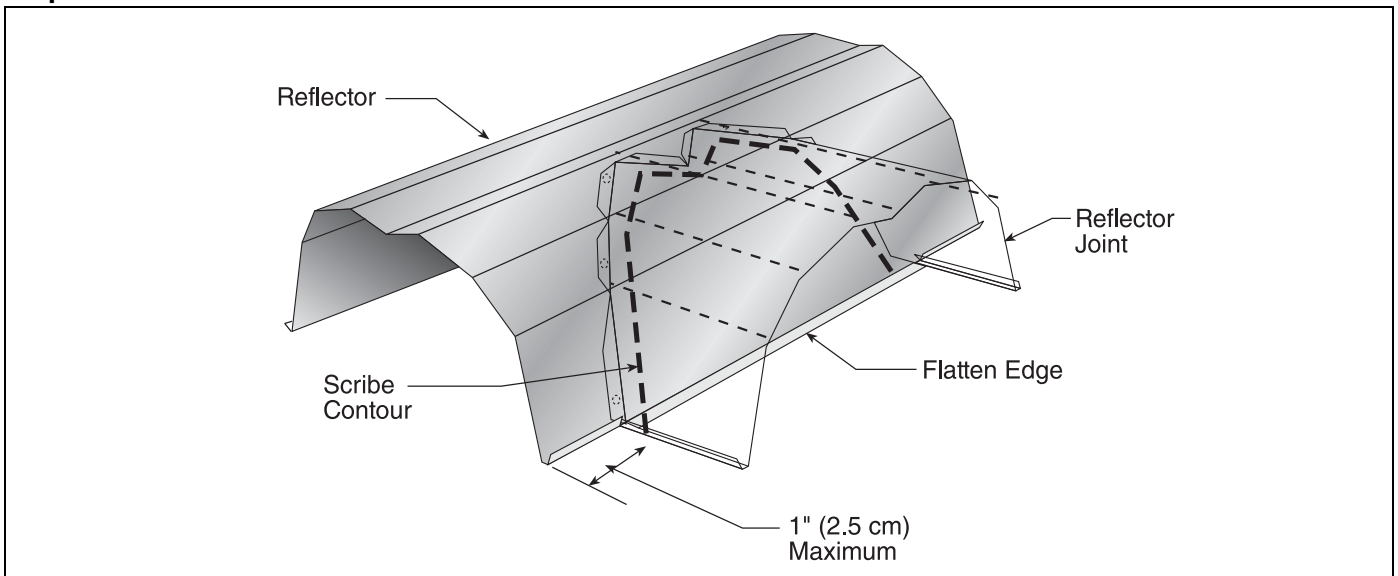
Description	Part Number
<b>Elbow Package</b>	<b>027187XX</b>
90° Elbow	01335801
Coupling	01312700
Reflector End Cap	027508XX
Reflector Joint Piece	027509XX
<b>U-Clip Package</b>	<b>91107720</b>

Minimum Distance Required Between Burner and Elbow	
Model	Minimum Distance
HEM-80	10' (3m)
HEM-115	15' (4.5m)
HEM-150	
HEM-200	

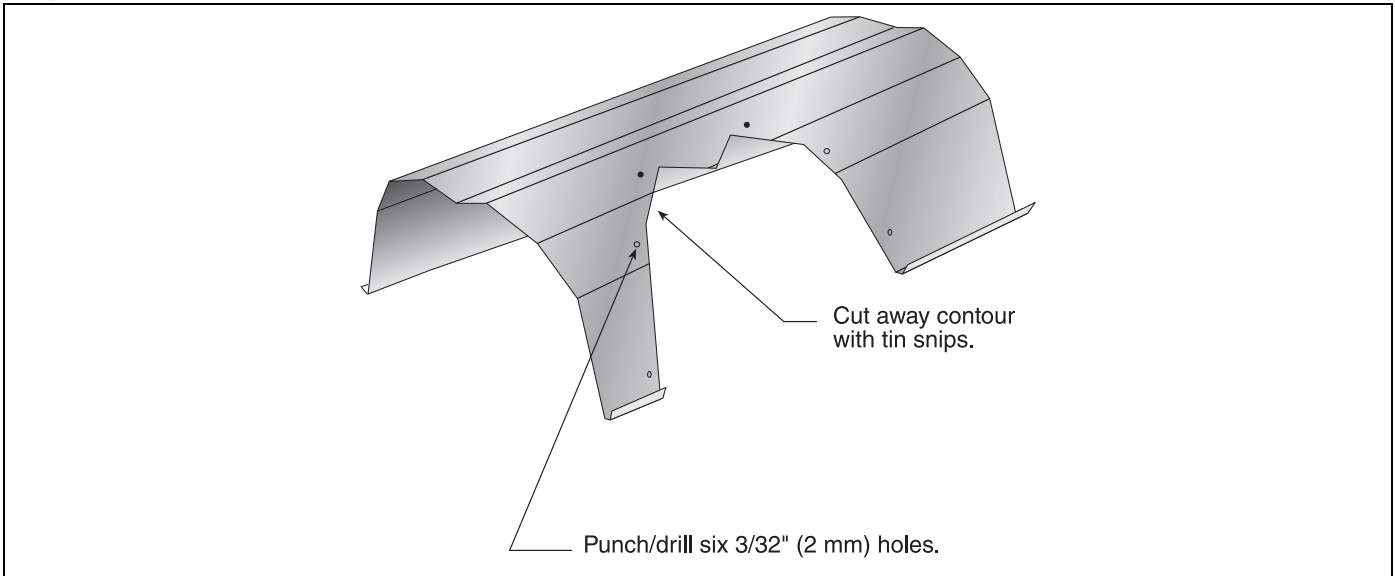
### Step 7.2.2 Elbow Installation



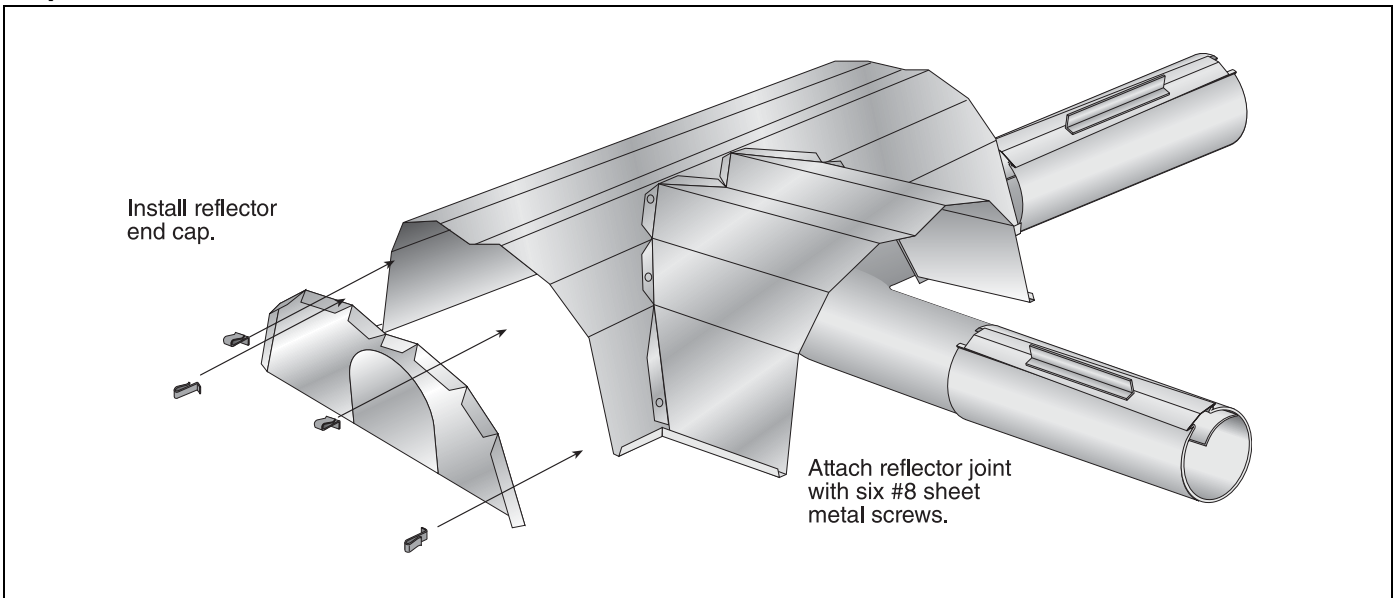
### Step 7.2.3 Reflector Joint Installation



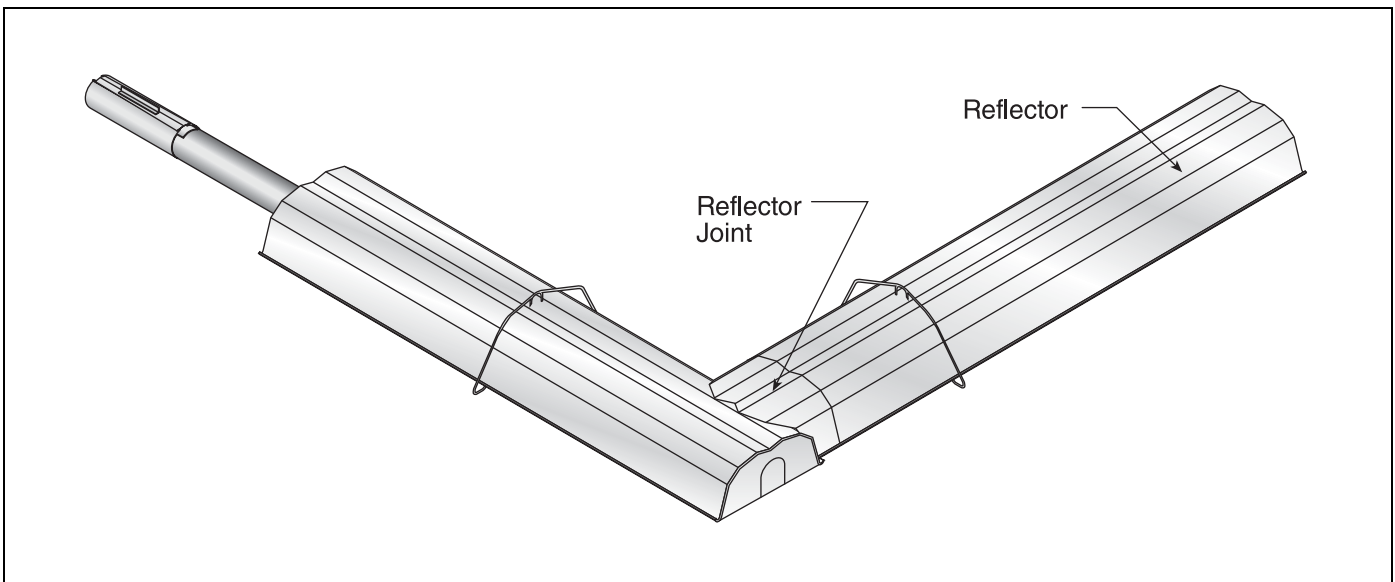
### Step 7.2.4 Reflector Joint Installation



### Step 7.2.5 Reflector Joint Detail

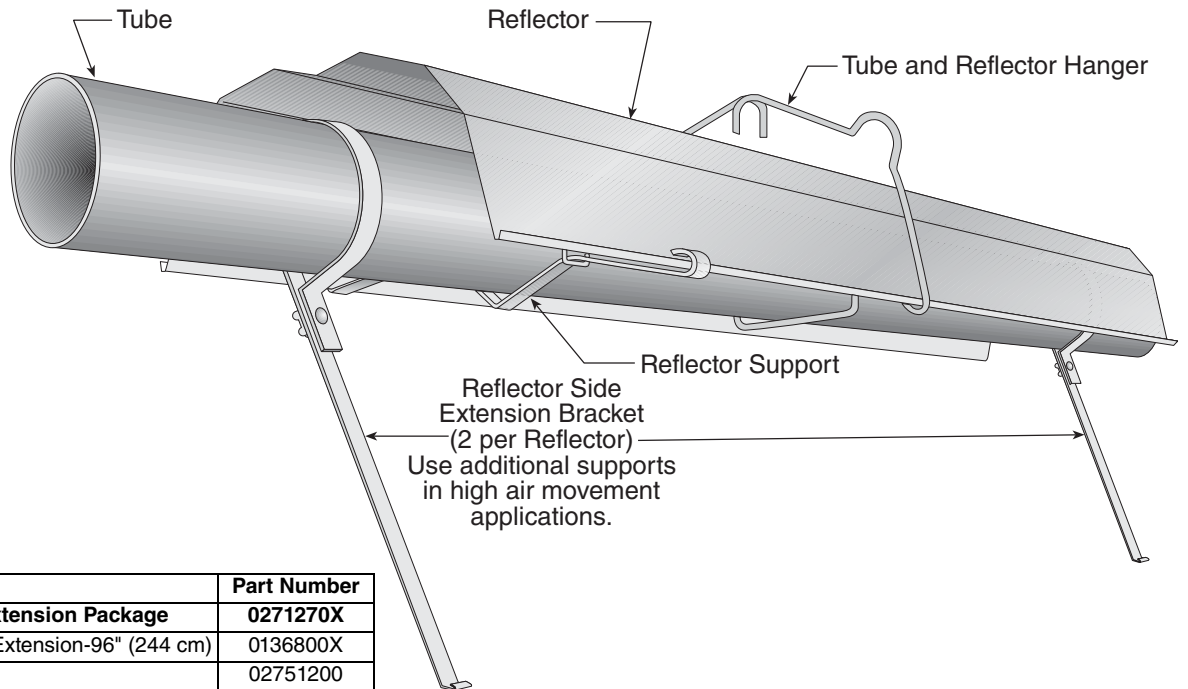


**FIGURE 21: Reflector Joint Detail**



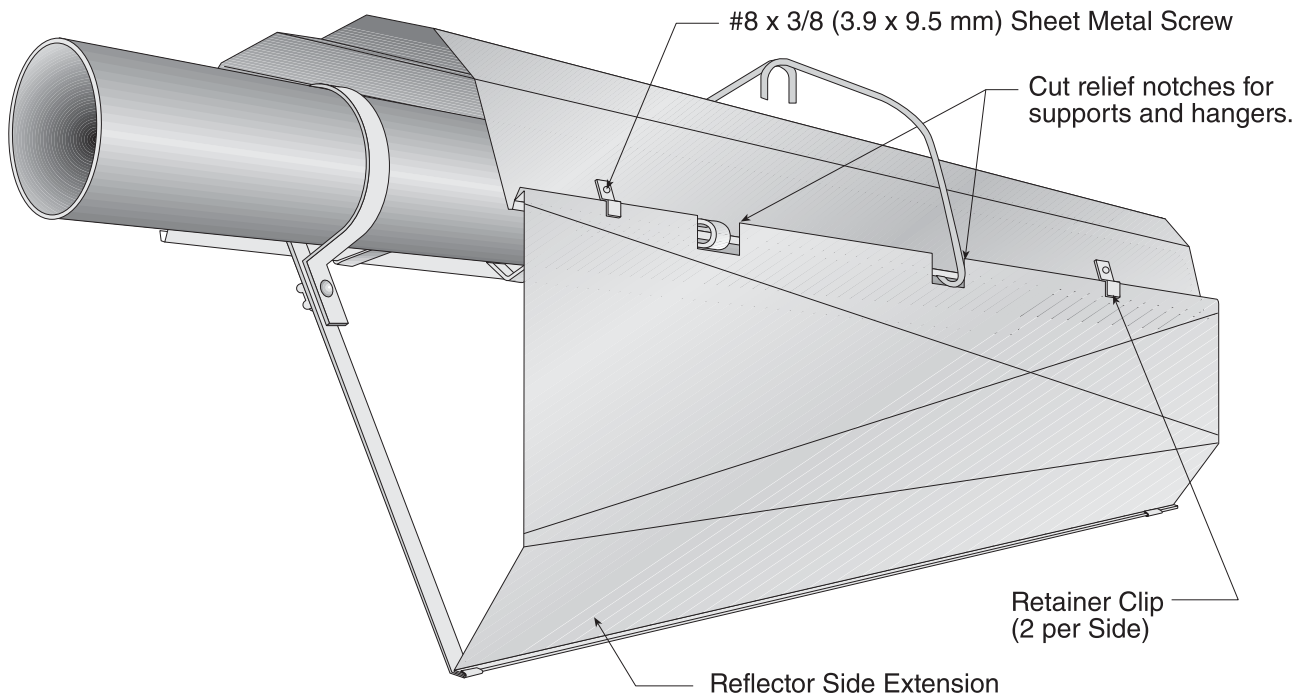
## 7.3 Reflector Side Extension

### Step 7.3.1 Bracket Installation



Description	Part Number
<b>Reflector Side Extension Package</b>	<b>0271270X</b>
Reflector Side Extension-96" (244 cm)	0136800X
Retainer Clips	02751200
Sheet Metal Screws	94118106
Order Separately	
Reflector Side Extension Bracket	01329911

### Step 7.3.2 Side Reflector Installation



### 7.4 Lower Clearance Shield Installation

#### Step 7.4.1 Shield Support Strap Assembly

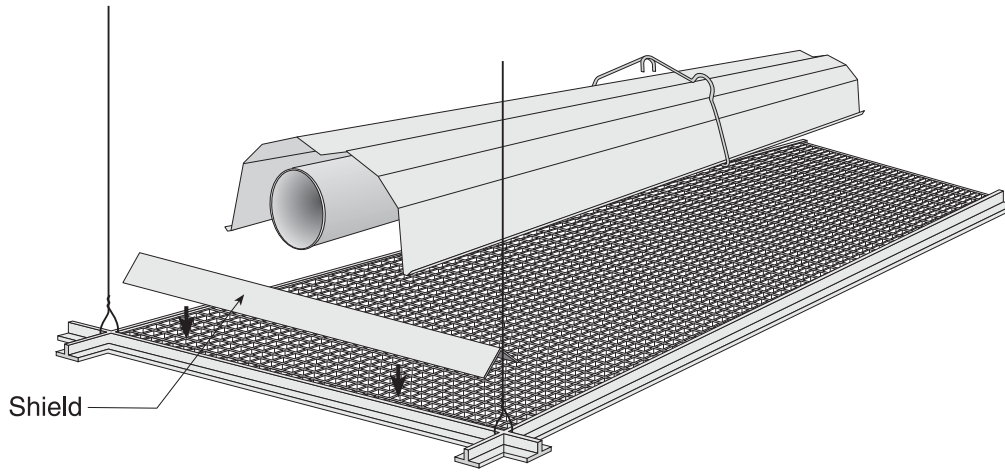
Description	Part Number
<b>Lower Clearance Shield Package</b>	<b>01397501</b>
Shield Support Strap	01397500
Lower Clearance Shield 8' (244 cm)	02793000
Locknut #8	92311400
Flat Washer #8	95310800
Screw #8 x 3/8"	93511406

### 7.5 Two-Foot Decorative Grille Installation

#### Step 7.5.1 Grille Installation

Description	Part Number
Aluminum Grille 2' x 4'	91407000

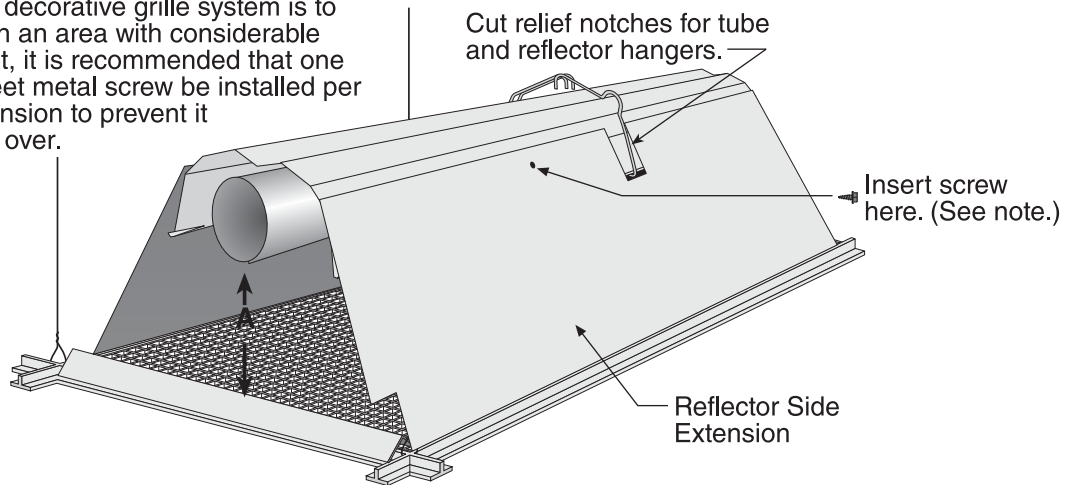
**Step 7.5.2 Frame Shield Installation**



Description	Part Number
Deco Grille Shield-24" (61 cm)	01365900

**Step 7.5.3 Reflector Side Extension Installation for Decorative Grilles**

**NOTE:** If the decorative grille system is to be installed in an area with considerable air movement, it is recommended that one #8 x 3/8" sheet metal screw be installed per reflector extension to prevent it from blowing over.

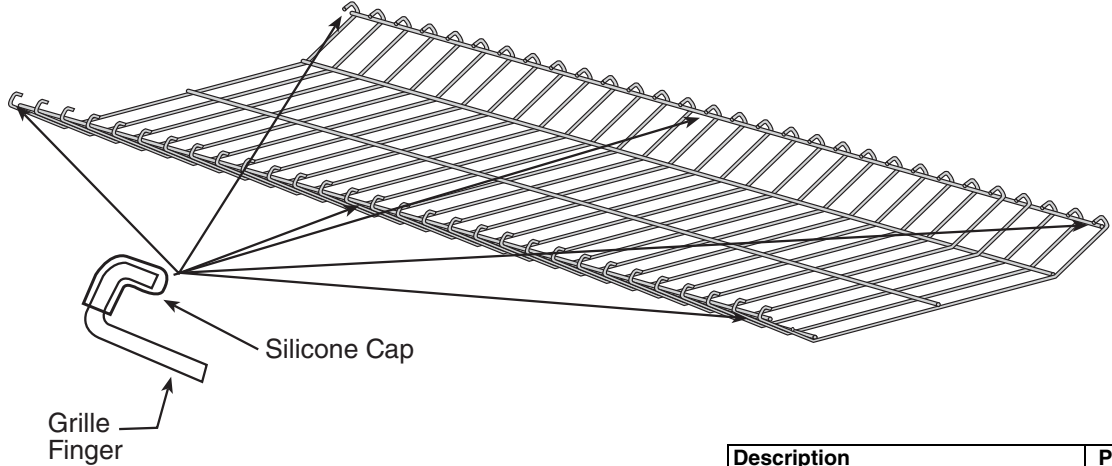


Distance "A"		Extension	
Minimum	Maximum	Part No.	Width
2" (4 cm)	6" (15 cm)	01370XXX	8" (20 cm)
6" (15 cm)	10" (26 cm)	01370XXX	12" (30 cm)
10" (26 cm)	14" (37 cm)	01370XXX	16" (40 cm)

Description	Part Number
Reflector Side Extension-48" (122 cm)	01370XXX

## 7.6 Protective Grille Installation

### Step 7.6.1 Silicone Cap Installation



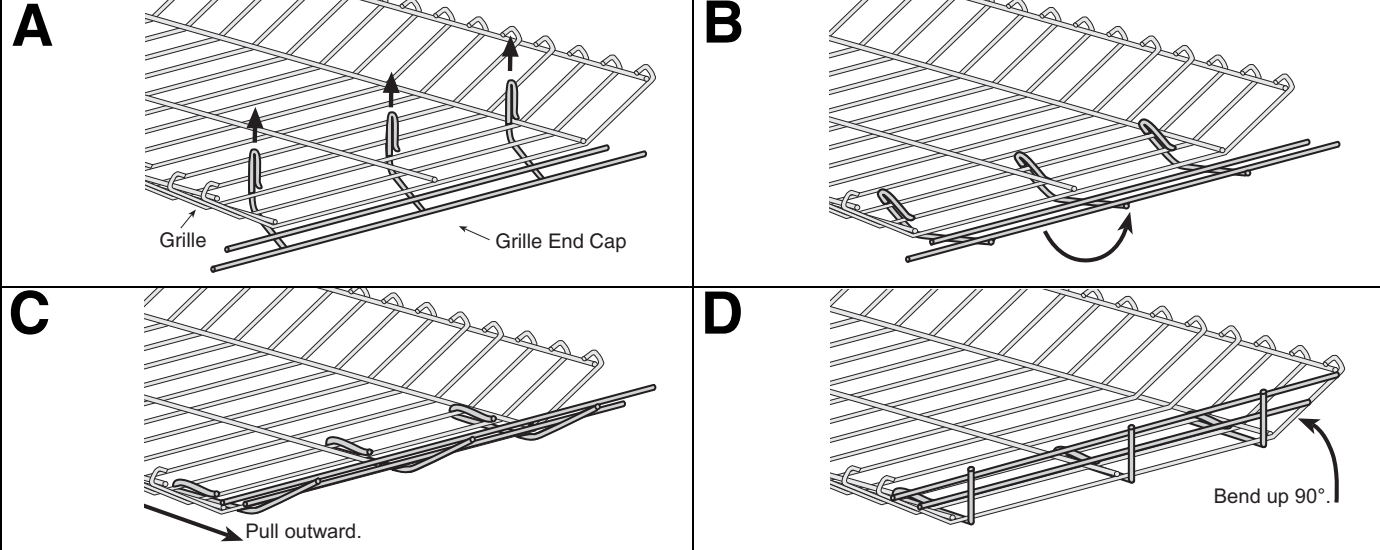
Grille Finger

Silicone Cap

**NOTE:** Protective grille available for use with standard reflector ONLY.

Description	Part Number
Grille Section	08050001
Grille End Cap	08050002
Silicone Cap	91915951-6P

### Step 7.6.2 Grille End Cap Installation



**A**

Grille

Grille End Cap

**B**

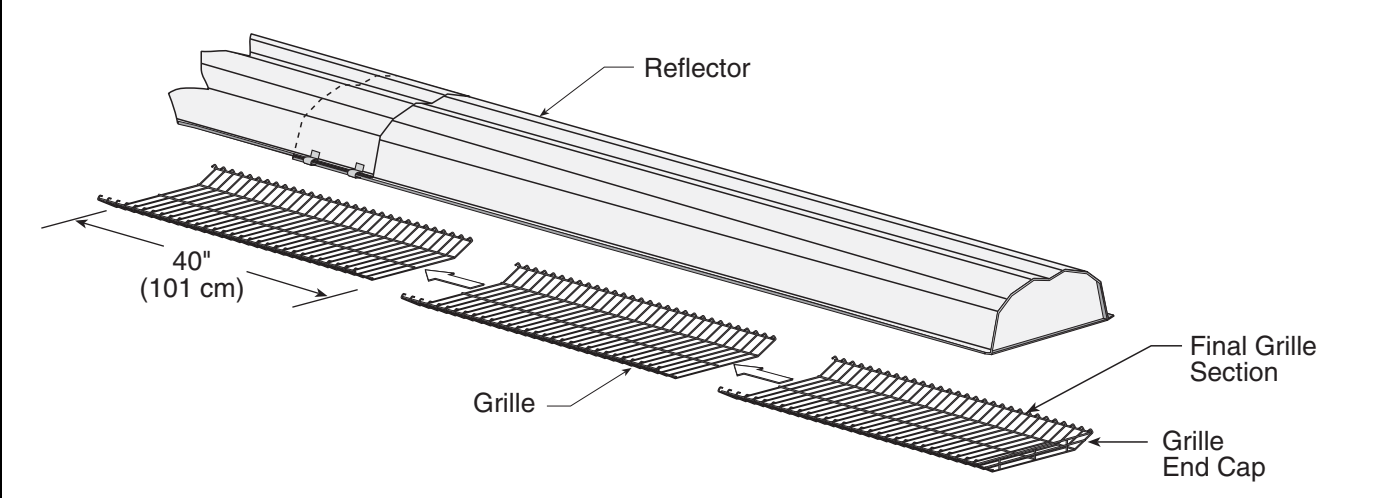
**C**

Pull outward.

**D**

Bend up 90°.

### Step 7.6.3 Grille Installation



Reflector

40"  
(101 cm)

Grille

Final Grille Section

Grille End Cap

## SECTION 8: VENTING

**! WARNING****Carbon Monoxide Hazard**

**Heaters installed unvented must be interlocked with sufficient building exhaust.**

**Heaters must be installed according to the installation manual.**

**Failure to follow these instructions can result in death or injury.**

**! WARNING****Cut/Pinch Hazard**

**Wear protective gear during installation, operation and service.**

**Edges are sharp.**

**Failure to follow these instructions can result in injury.**

**8.1 Venting**

This heater must be vented in accordance with the rules contained in this manual and with the following national codes and any state, provincial or local codes which may apply:

**United States:** Refer to National Fuel Gas Code NFPA 54/ANSI Z223.1 - latest revision.

**Canada:** Refer to Natural Gas and Propane Installation Code CSA B149.1 - latest revision.

Exhaust end of heater will accept a 4" (10 cm) vent pipe using the vent adapter (P/N 90502700). To prevent leakage of condensation, install the vent adapter with the seam on top and seal the joint using a high temperature silicone sealant.

Any portion of vent pipe passing through a combustible wall must have an approved thimble to conform with the above listed codes.

Vent pipe must be sloped downward away from the burner 1/2" (1 cm) for every 20' (6 m).

The heater may be individually vented or common vented. When venting horizontally, a maximum of two heaters can be commonly vented. See Page 39, Section 8.10. When venting vertically, a maximum of four heaters can be commonly vented. See Page 40, Section 8.11.

The heater may also be installed unvented in certain circumstances according to building ventilation codes. Refer to the above codes and Page 35, Section 8.2 for further information. Unvented operation also requires compliance with the clearances to combustibles given on Page 8, Figure 12.

The bottom of the vent or air intake terminal shall not be located less than 1' (.3 m) above grade level.

The vent shall not terminate less than 7' (2.1 m) above grade where located adjacent to public walkways.

Vent terminal must be installed at a height sufficient to prevent blockage by snow and building materials protected from degradation by flue gasses.

Secure all joints with #8 x 3/8 sheet metal screws. Seal all joints with high temperature silicone sealant.

Vent terminal must be beyond any combustible overhang.

**8.1.1 United States Requirements**

Vent must terminate at least 3' (.9 m) above any forced air inlet located within 10' (3.1 m).

Vent must terminate at least 4' (1.2 m) below, 4' (1.2 m) horizontally from, or 1' (.3 m) above any door, operable window, or gravity air inlet into any building.

**8.1.2 Canadian Requirements**

The vent shall not terminate within 6' (1.8 m) of a mechanical air supply inlet to any building.

The vent shall not terminate within 3' (.9 m) of a window or door that can be opened in any building, any non-mechanical air supply inlet to any building, or of the combustion air inlet of any other appliance.

**8.2 Unvented Operation**

Sufficient ventilation must be provided in the amount of 4 cfm per 1000 Btu/h firing rate (United States); 3 cfm per 1000 Btu/h firing rate (Canada).

Use of optional outside combustion air is not recommended with unvented heaters.

If exhaust fans are used to supply ventilation air, an interlock switch must be used to prevent the heater from coming on when the fans are off. This may be done using a pressure switch.



### 8.3 Horizontal Venting

In noncombustible walls only, vent terminal (P/N 02537801-1P) may be used.

For 4" (10 cm) vents in either combustible or noncombustible walls, use Tjernlund VH1-4 (P/N 90502100) or equivalent, insulated vent terminal. Follow the manufacturer's instructions for proper installation.

For 6" (15 cm) common vents in either combustible or noncombustible walls, use Tjernlund VH1-6 (P/N 90502101) or equivalent, insulated vent terminal. Follow the manufacturer's instructions for proper installation.

### 8.4 Vertical Venting

For 4" (10 cm), an approved vent cap (P/N 90502300) must be used.

For 6" (15 cm) common vent, an approved vent cap (P/N 90502302) must be used.

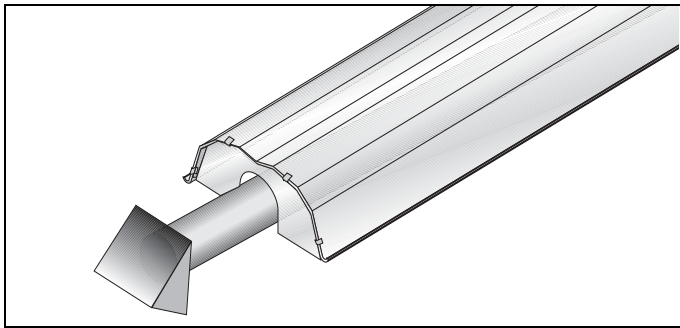
For common vertical venting of more than two heaters, See Page 40, Section 8.11.

A vent shall not extend less than 2' (.6m) above the highest point where it passes through a flat roof of a building.

### 8.5 Unvented Operation Tube Termination

Turndown type vent terminal with a screen must be installed at the exhaust end of the tube. Vent terminal design shall not incorporate backdraft flap.

**FIGURE 22: Tube Termination**



### 8.6 Length Requirements

The maximum vent length allowed is 45' (13.7 m). The maximum outside air supply duct length allowed is 45' (13.7 m).

The total vent length, plus outside air duct length and any extensions to minimum heat exchanger lengths, cannot exceed 65' (19.8 m).

Vent length should be limited to less than 20' (6 m). If using extended heater lengths or vent lengths greater than 20' (6 m), condensation will form in the vent pipe. Insulation and additional sealing measures (high temperature silicone at all seams) are required. Optional heat exchanger beyond minimum lengths are considered as vent length for length determination.

Subtract 15' (4.6 m) of maximum allowed vent or duct

length per vent elbow if more than two are used.

### 8.6.1 Vent Material Recommendations

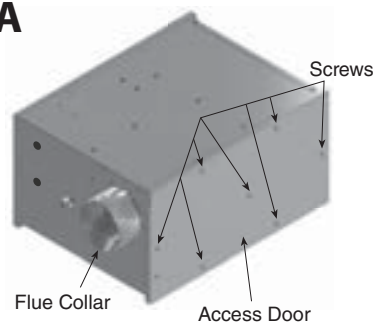
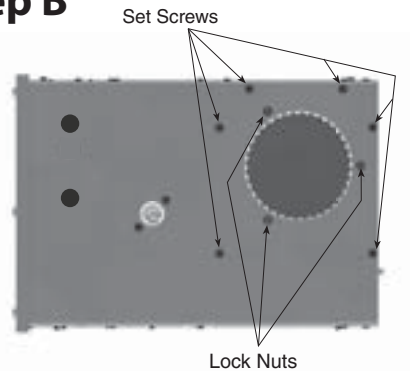
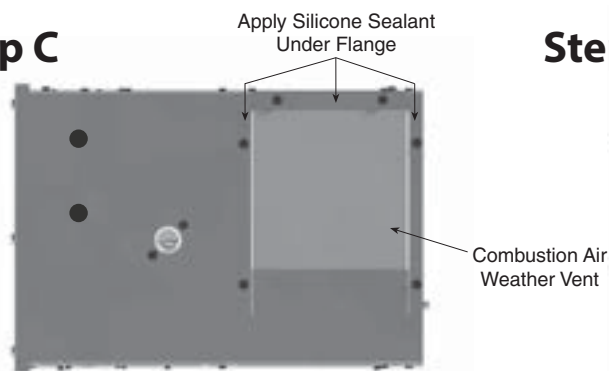
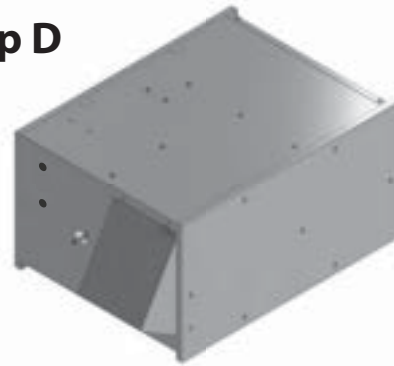
Vent recommendations:

1. Porcelain coated tubing 4" (10 cm) O.D. (P/N 9141030D)
2. Heat treated aluminized tubing 4" (10 cm) O.D. (P/N 91409408)  
Heat treated aluminized tubing 6" (15 cm) O.D. (P/N E0009105)
3. Single wall flue pipe - minimum 26 ga. (Supplied by others)

**NOTE:** 4" (10 cm) O.D. Porcelain coated tubing (P/N 914030D), 4" (10 cm) O.D. Heat treated aluminized tubing (P/N 91409408), and 6" (15 cm) O.D. Heat treated aluminized tubing (P/N E0009105) are equivalent to single wall flue pipe.

**FIGURE 23: Combustion Air Weather Vent (P/N 03700009)**

To be installed in place of flue collar for installations without fresh air vent pipe.

**Step A****Step B****Step C****Step D**

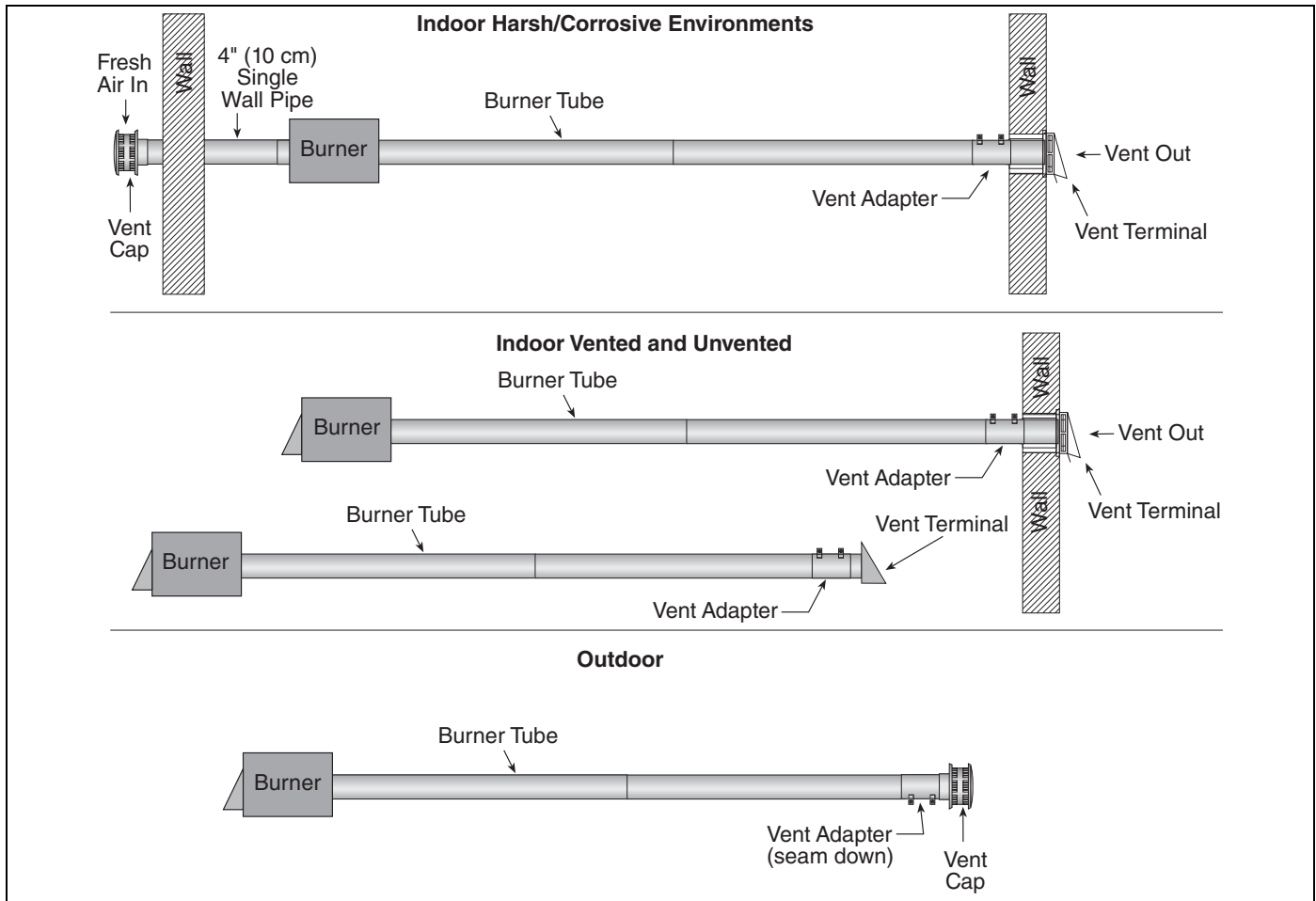
**Step A:** Remove blower side access door from burner by unscrewing the 7 screws as shown. Carefully remove door to gain access to combustion blower.

**Step B:** Unscrew 3 lock nuts along with 6 set screws from rear of unit as shown. Pull combustion blower from burner and remove flue collar. While keeping blower gasket and bird screen in place, replace combustion blower and tighten locknuts previously removed in step A.

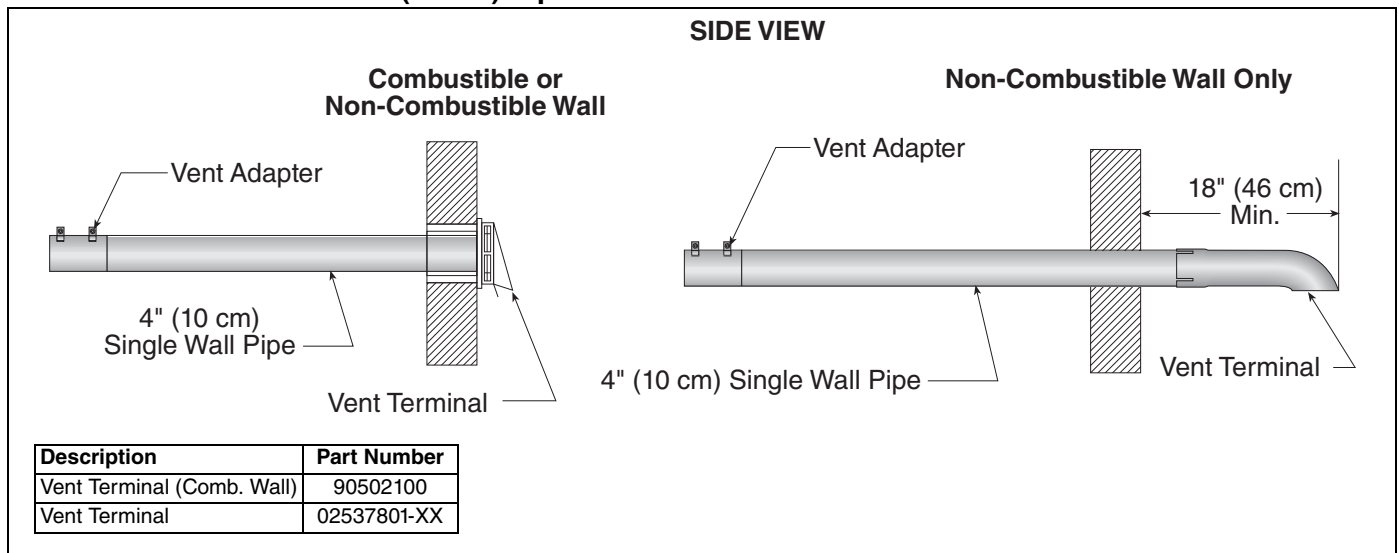
**Step C:** Apply silicone sealant around Combustion Air Weather Vent flange. Carefully align 6 pre-drilled holes on weather vent flange to 6 holes on burner. Tighten 6 set screws previously removed in step 2 to secure weather vent to burner.

**Step D:** Reinstall access door and tighten screws.

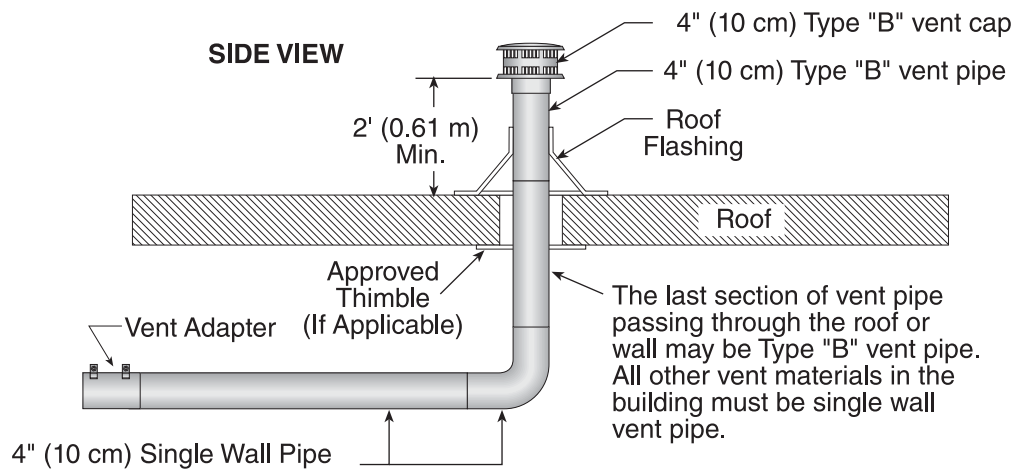
### 8.7 Venting Options



### 8.8 Horizontal Ventilation 4" (10 cm) Pipe

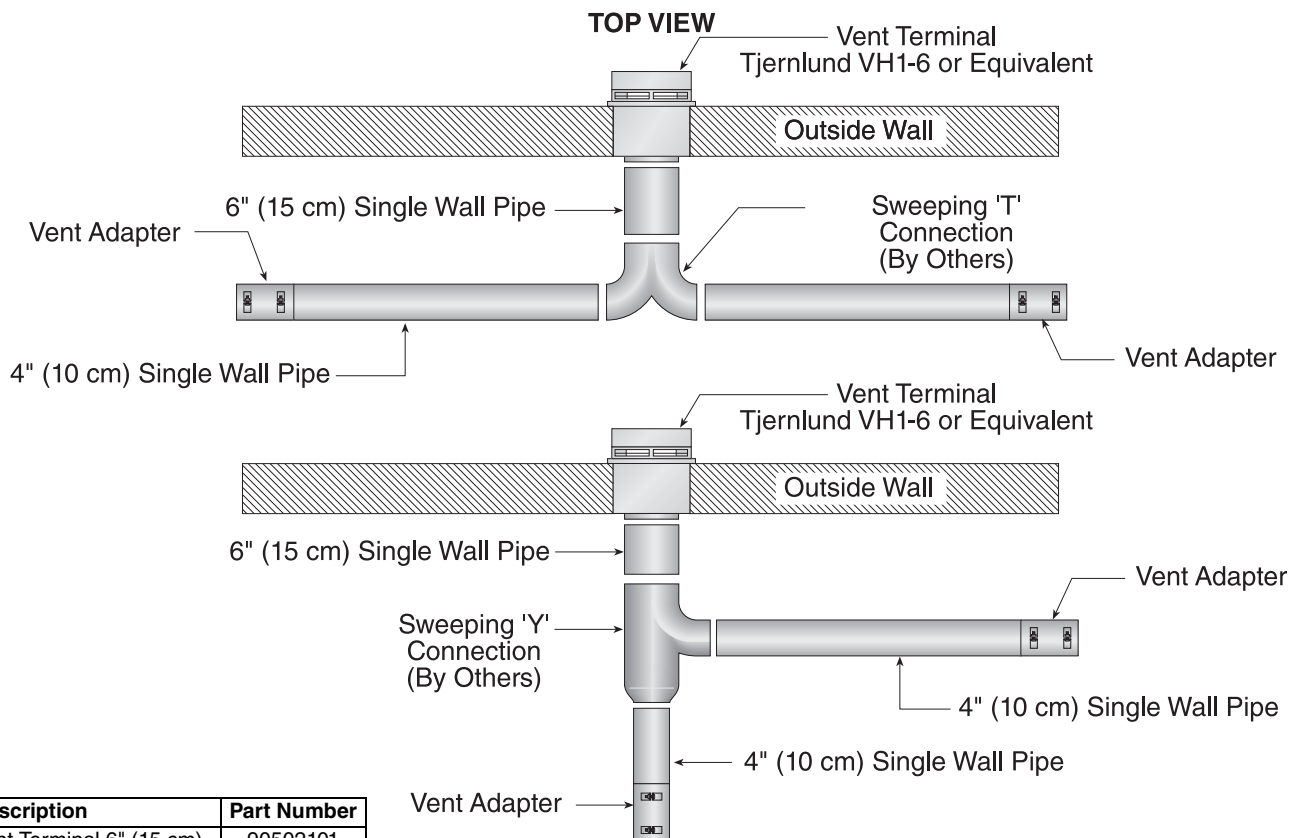


### 8.9 Vertical Ventilation 4" (10 cm) Pipe



Description	Part Number
Vent Cap 4" (10 cm)	90502300

### 8.10 Common Side Wall Venting

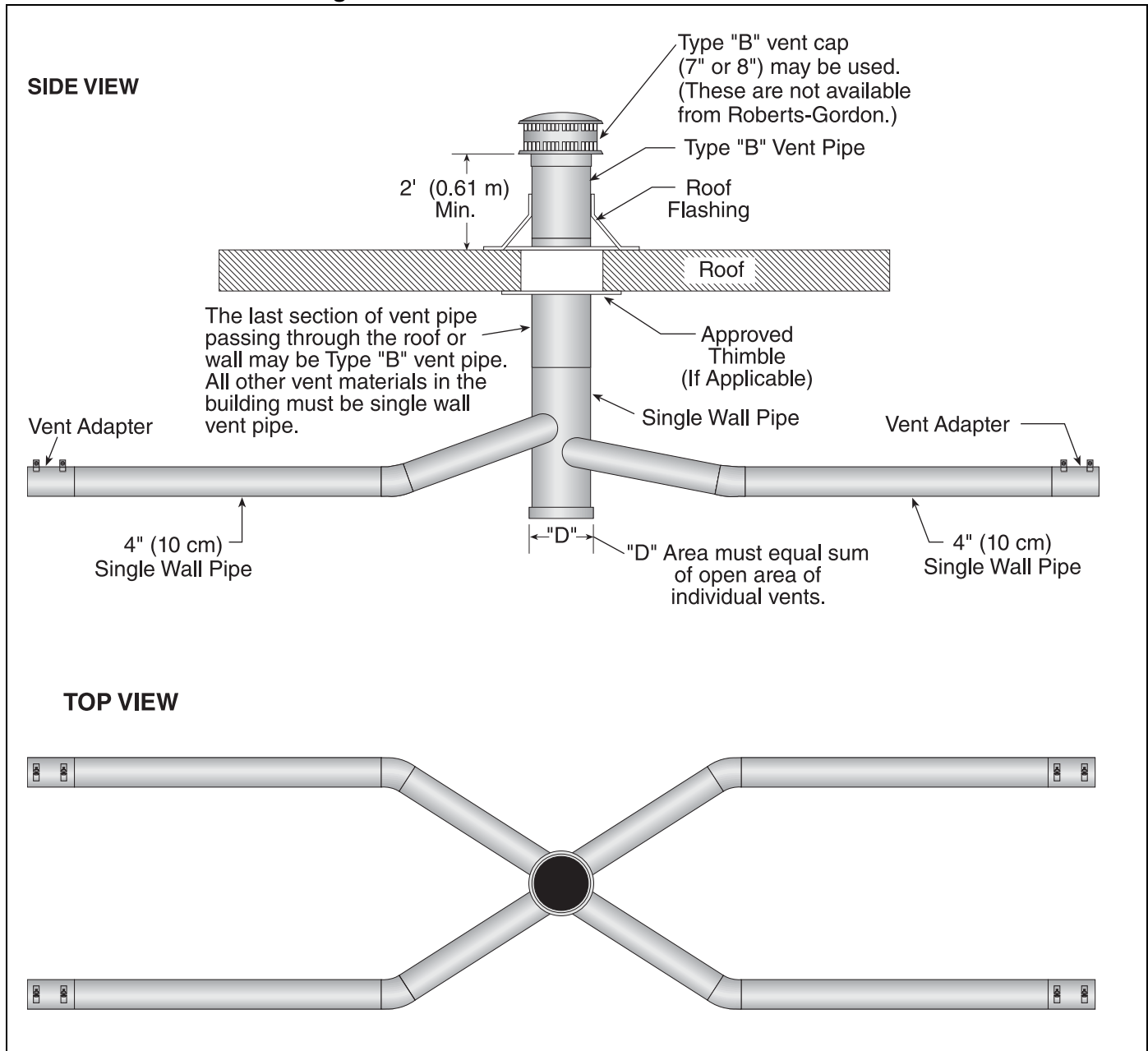


Description	Part Number
Vent Terminal 6" (15 cm)	90502101

#### Requirements:

- Maximum of two heaters can be commonly vented through a side wall.
- Heaters must be of the same BTU output.
- Heaters must be controlled by a common thermostat.

## 8.11 Common Vertical Venting



### Requirements:

- Maximum of four heaters can be commonly vented through the roof.
- Heaters must be of the same BTU output.
- Heaters must be controlled by a common thermostat.
- Connections to a common stack must be positioned to avoid direct opposition between streams of combustion gases.

## 8.12 Outside Combustion Air Supply

**IMPORTANT:** If the building has a slight negative pressure or corrosive contaminants such as halogenated hydrocarbons are present in the air, an outside combustion air supply to the heater is required. Seal all combustion air pipe joints.

The air supply duct may have to be insulated to prevent condensation on the outer surface. The outside air terminal must not be more than 1' (31 cm) above the vent termination while maintaining a distance of 3' (93 cm) for both vertical and horizontal venting.

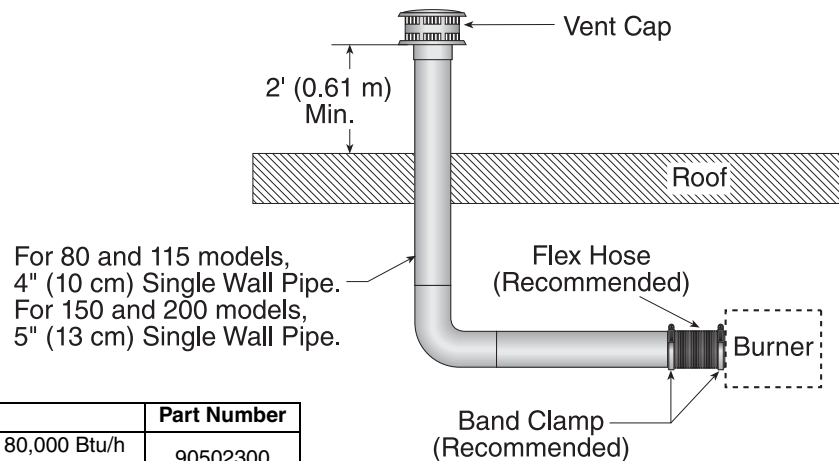
Use of optional outside combustion air is not recommended with unvented heaters.

### 8.12.1 Length Requirements

Follow the constraints listed on Page 36, Section 8.6.

### 8.12.2 Vertical Outside Air Supply for Single Heater Installation

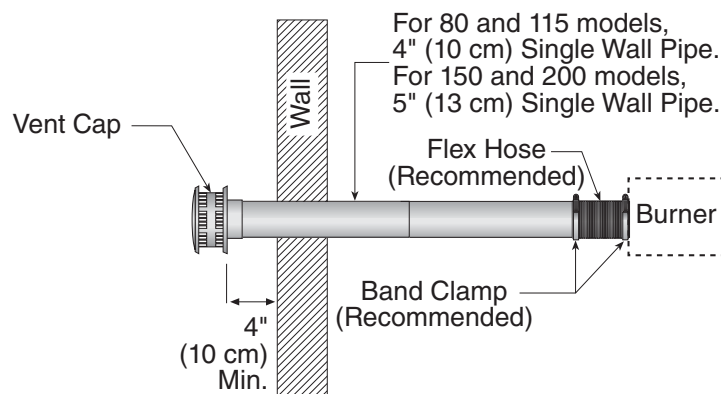
#### SIDE VIEW



Description	Part Number
Vent Cap 4" (10 cm) for 80,000 Btu/h and 115,000 Btu/h models	90502300
Vent Cap 5" (13 cm) for 150,000 Btu/h and 200,000 Btu/h models	90502301

### 8.12.3 Horizontal Outside Air Supply for Single Heater Installation

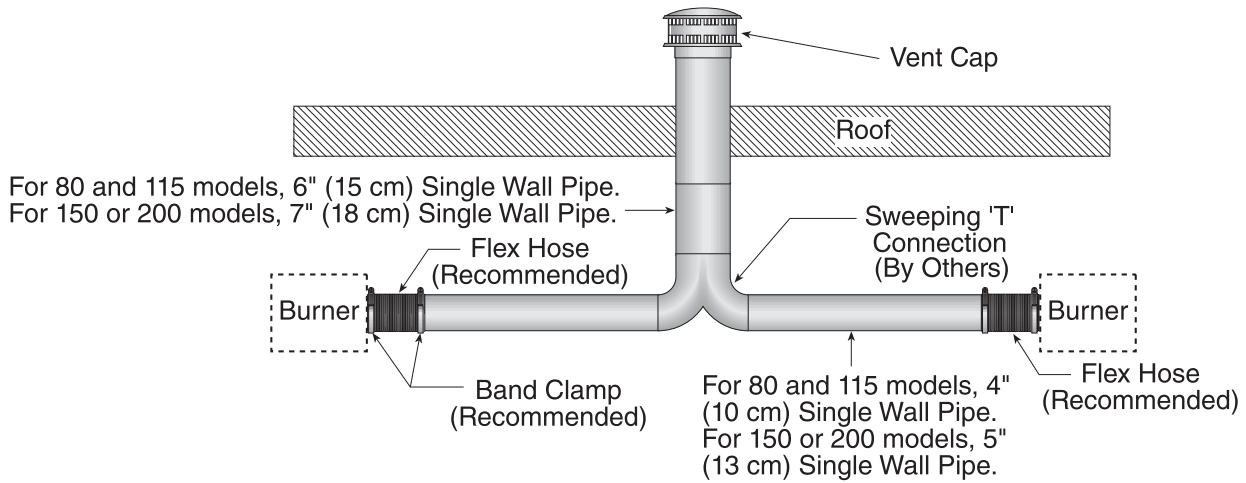
#### SIDE VIEW



Description	Part Number
Vent Cap 4" (10 cm) for 80,000 Btu/h and 115,000 Btu/h models	90502300
Vent Cap 5" (13 cm) for 150,000 Btu/h and 200,000 Btu/h models	90502301

### 8.12.4 Vertical Outside Air Supply for Double Heater Installation

#### SIDE VIEW



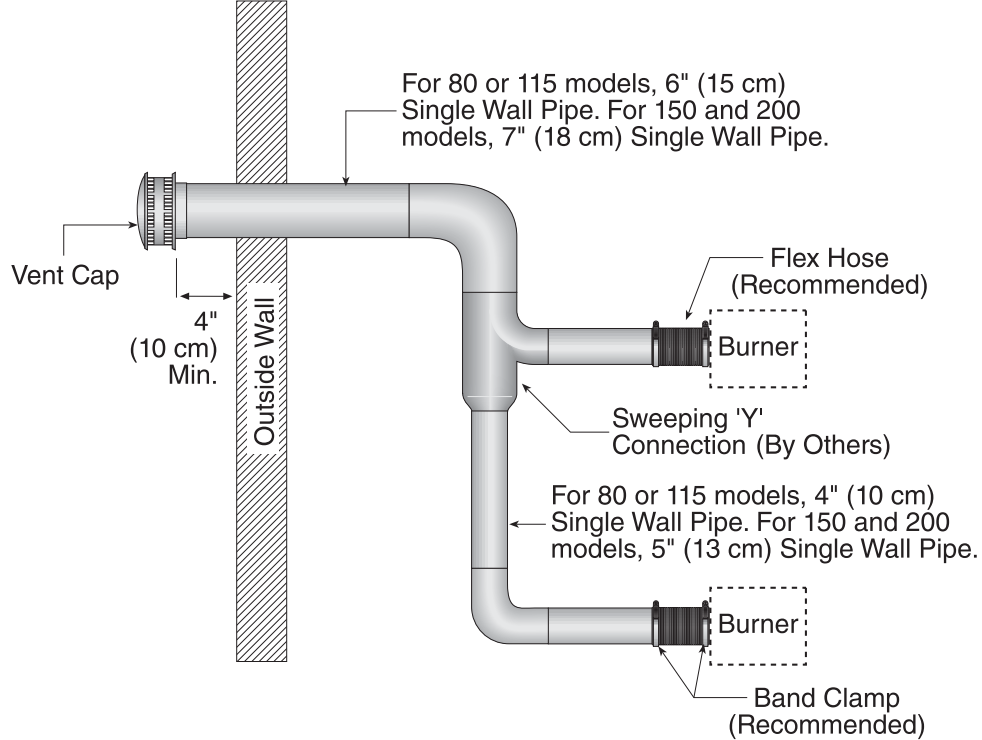
Description	Part Number
Vent Cap 6" (15 cm)	90502302

#### Requirements:

- Heaters must be controlled by a common thermostat.

### 8.12.5 Horizontal Outside Air Supply for Double Heater Installation

#### TOP VIEW



Description	Part Number
Vent Cap 6" (15 cm)	90502302

#### Requirements:

- Heaters must be controlled by a common thermostat.

## SECTION 9: GAS PIPING

**! WARNING****Fire Hazard**

**Tighten gas hose fittings to connect gas supply according to Figure 21.**

**Gas hose can crack when twisted.**

**Gas hose moves during normal operation.**

**Use only 36" (91 cm) long connector of 1/2" or 3/4" nominal ID.**

**Connector supplied with heater for U.S. models (not with Canadian models).**

**Failure to follow these instructions can result in death, injury or property damage.**

**! WARNING****Explosion Hazard**

**Leak test all components of gas piping before operation.**

**Gas can leak if piping is not installed properly.**

**Do not high pressure test gas piping with heater connected.**

**Failure to follow these instructions can result in death, injury or property damage.**

There is an expansion of the tube with each firing cycle. This will cause the burner to move with respect to the gas line. This can cause a gas leak resulting in an unsafe condition if the gas connection is not made in strict accordance with *Figure 24*.

Meter and service must be large enough to handle all the burners being installed plus any other connected load. The gas line which feeds the system must be large enough to supply the required gas with a maximum pressure drop of 1/2" wc. When gas piping is not included in the layout drawing, the local gas supplier will usually help in planning the gas piping.

Gas lines must meet applicable codes:

**United States:** The Flexible Stainless Steel Gas Hose (US models) supplied with the heater is certified per the Standard for Connectors for Gas Appliances, ANSI Z21.24/CSA 6.10 - latest revision.

**Canada:** The Rubber Type 1 Gas Hose (Canadian models) optional with the heater is certified as being in compliance with the Standard for Elastomeric Composite Hose and Hose Couplings for Conducting Propane and Natural Gas, CAN/CGA 8.1 - Latest revision.

- **Check the pipe and tubing ends for leaks before placing heating equipment into service. When checking for gas leaks, use a soap and water solution; never use an open flame.**

Install the gas hose as shown in *Figure 24*. The gas hose accommodates expansion of the heating system and allows for easy installation and service of the burner. Before connecting the burners to the supply system, verify that all high pressure testing of the gas piping has been completed.



**FIGURE 24: Gas Connection with Flexible Gas Hose**

**CORRECT POSITIONS**

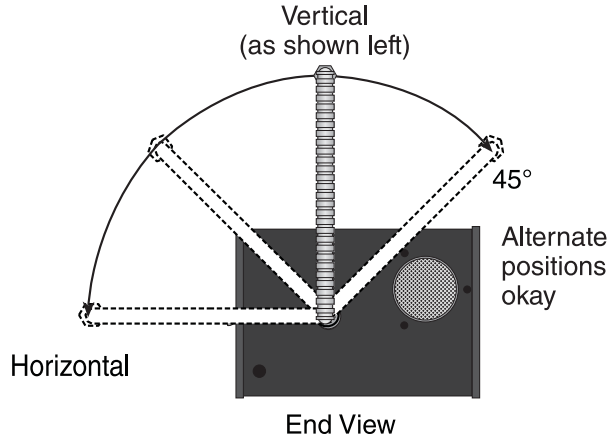
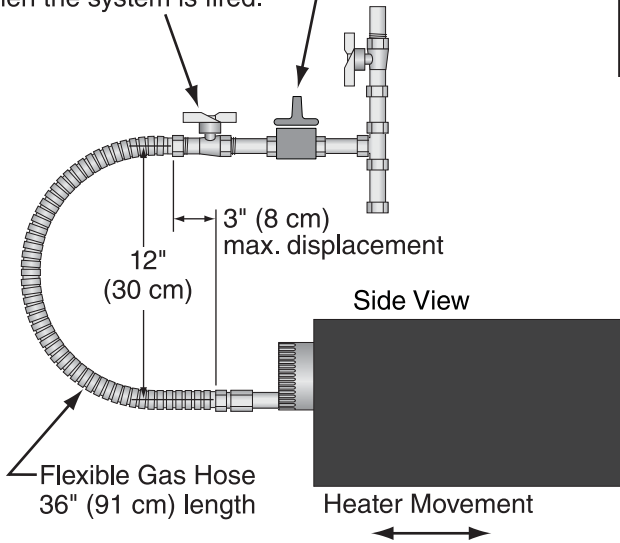
Shut-Off Valve (included with gas hose) must be parallel to burner gas inlet. The 3" (8 cm) displacement shown is for the cold condition. This displacement may reduce when the system is fired.

High Gas Pressure Regulator to be installed upstream of flexible gas hose if inlet pressure exceeds maximum allowance. See Page 74, Section 14

**⚠ CAUTION**  
Product Damage Hazard

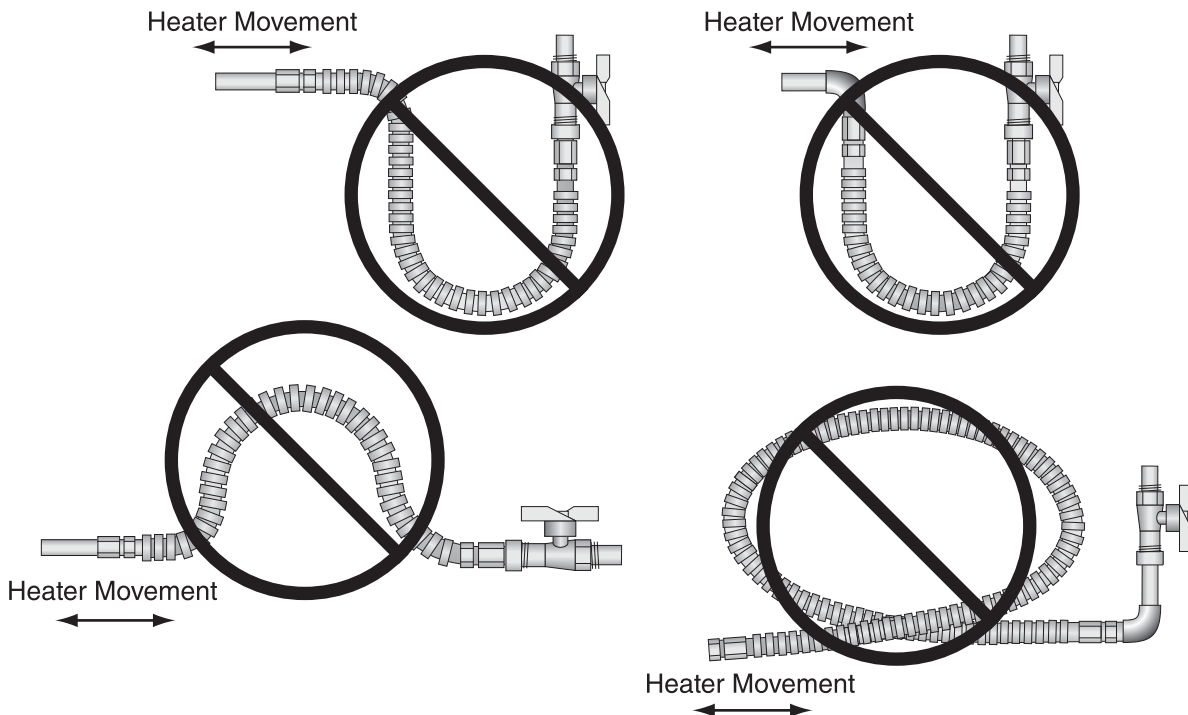
**Hold gas nipple securely with pipe wrench when attaching gas hose.**

**Failure to follow these instructions can result in product damage.**



Description	Part Number
3.High Pressure Regulator - 2 psi	90207600
3.High Pressure Regulator - 5 psi	90207601

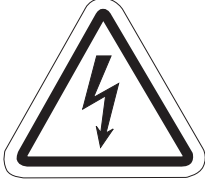
**INCORRECT POSITIONS (WRONG INSTALLATION)**



Description	Part Number
3/4" x 36" Vinyl Coated Flex Stainless Steel Gas Line (US Models Only)	91412200

SECTION 10: WIRING

**⚠ DANGER**



**Electrical Shock Hazard**

**Disconnect electric before service.**

**Heater must be properly earthed.**

**Failure to follow these instructions can result in death or electrical shock.**

Heater must be grounded in accordance with applicable codes: United States: refer to National Electrical Code® NFPA 70 - latest revision  
 Canada: refer to Canadian Electrical Code, CSA C22.1 Part I - latest revision.

If any of the original internal wiring must be replaced, it must be replaced with wiring materials having a temperature rating of at least 105°C and 600 Volts.

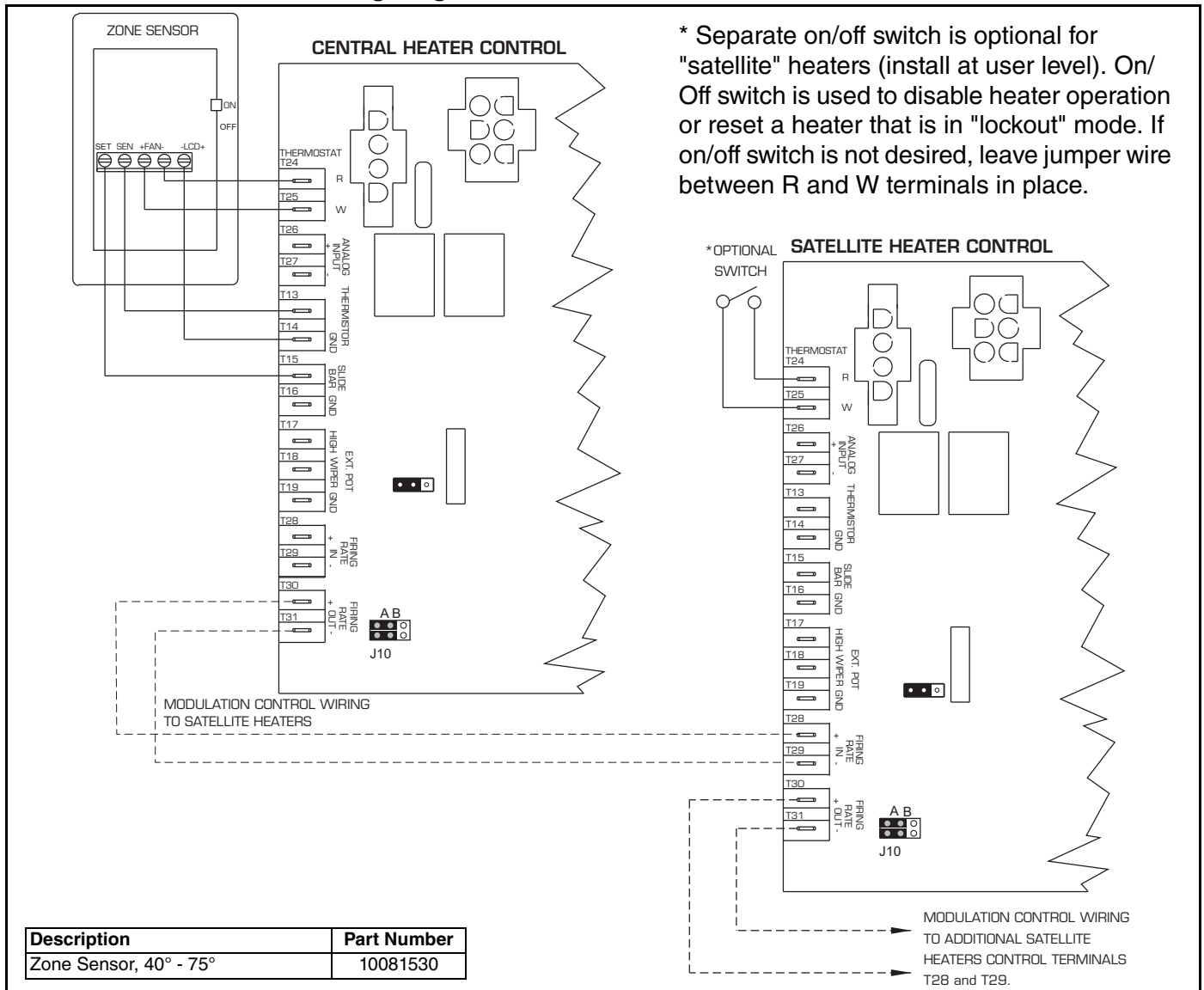
**10.1 Standard Heater Configuration**

From the factory, the heater is configured for zone sensor control. Connect zone sensor to the heater control as shown on Page 45, Figure 25.

If additional heaters are in the same heating zone, control wiring must be installed between the heaters' controls as shown on Page 45, Figure 25.

For additional details or for use with heat demand control devices other than the zone sensor, see Page 46, Section 10.2 through Page 54, Section 10.4.9.

**FIGURE 25: Zone Sensor Wiring Diagram**



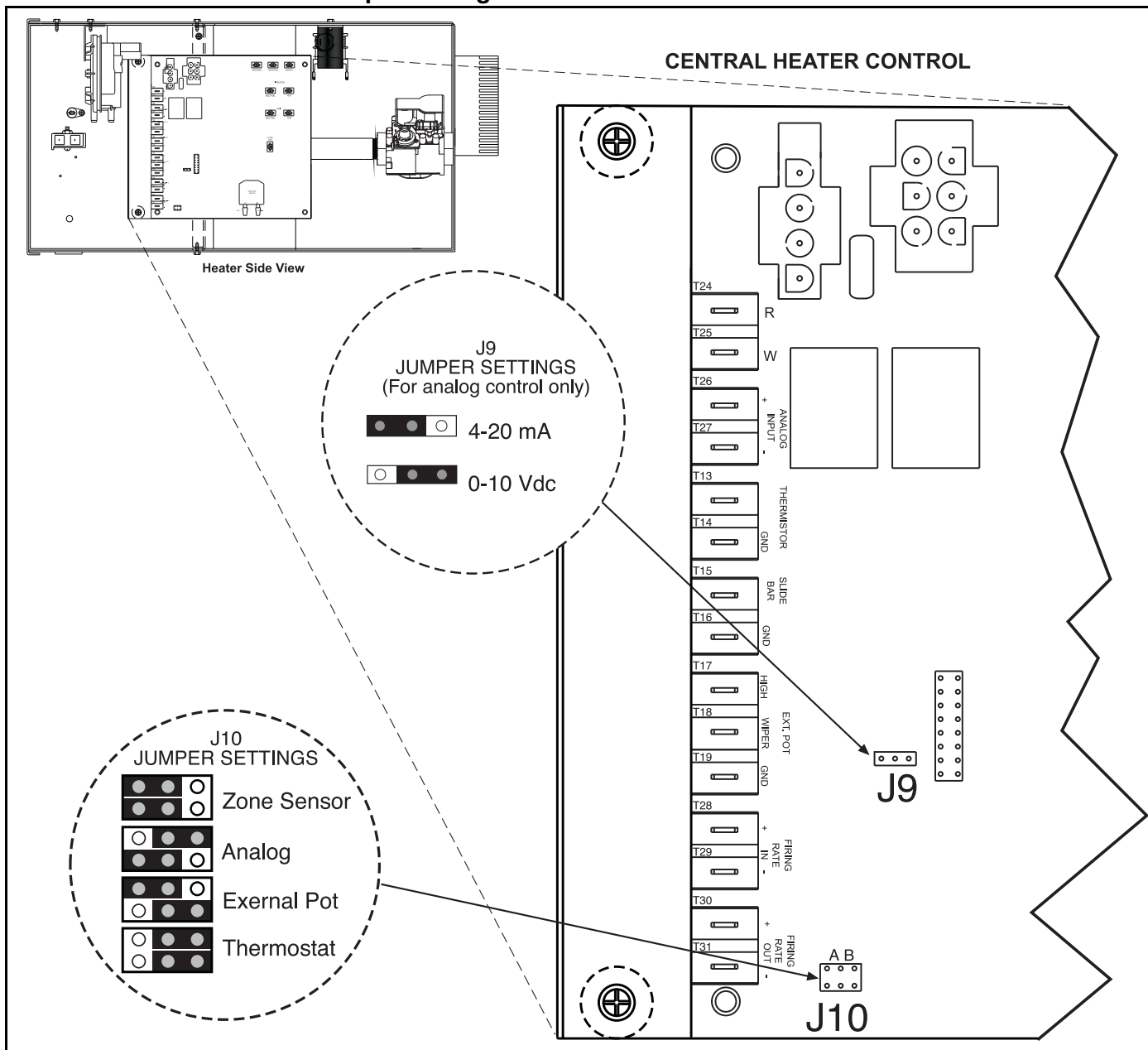
## 10.2 Central and Satellite Heaters (Zoning Capability)

The heater can be configured so that several heaters within the same heating zone will modulate simultaneously with connection to a single heat demand control device. The heat demand control device (See Page 50, Section 10.4) will be wired directly to a single heater configured as the central heater. The remaining heaters in the zone will be configured as satellite heaters and will modulate based on control signaling from the central heater. Zoning capability allows any CTH3-Series heater (regardless of input) to modulate based on the signal from the central heater. During modulation, each satellite heater will operate at the same percentage of full rated input as the central heater.

### 10.2.1 Central Heater Configuration

Central heater configuration is set by positioning of jumpers on pin blocks (J10 and J9) located on the control inside the heater compartment, See Page 46, Figure 26. Jumper position on J10 shown in Figure 26, will configure heater as a central heater and at the same time configure the heater for the desired heat demand device (zone sensor, thermostat, analog input, or 10K Ohm pot.). If jumpers on J10 are positioned for "analog", jumper on J9 must be positioned for either 0-10 Vdc or 4-20 mA. If jumpers on J10 are not positioned for "analog", the J9 jumper may be left alone.

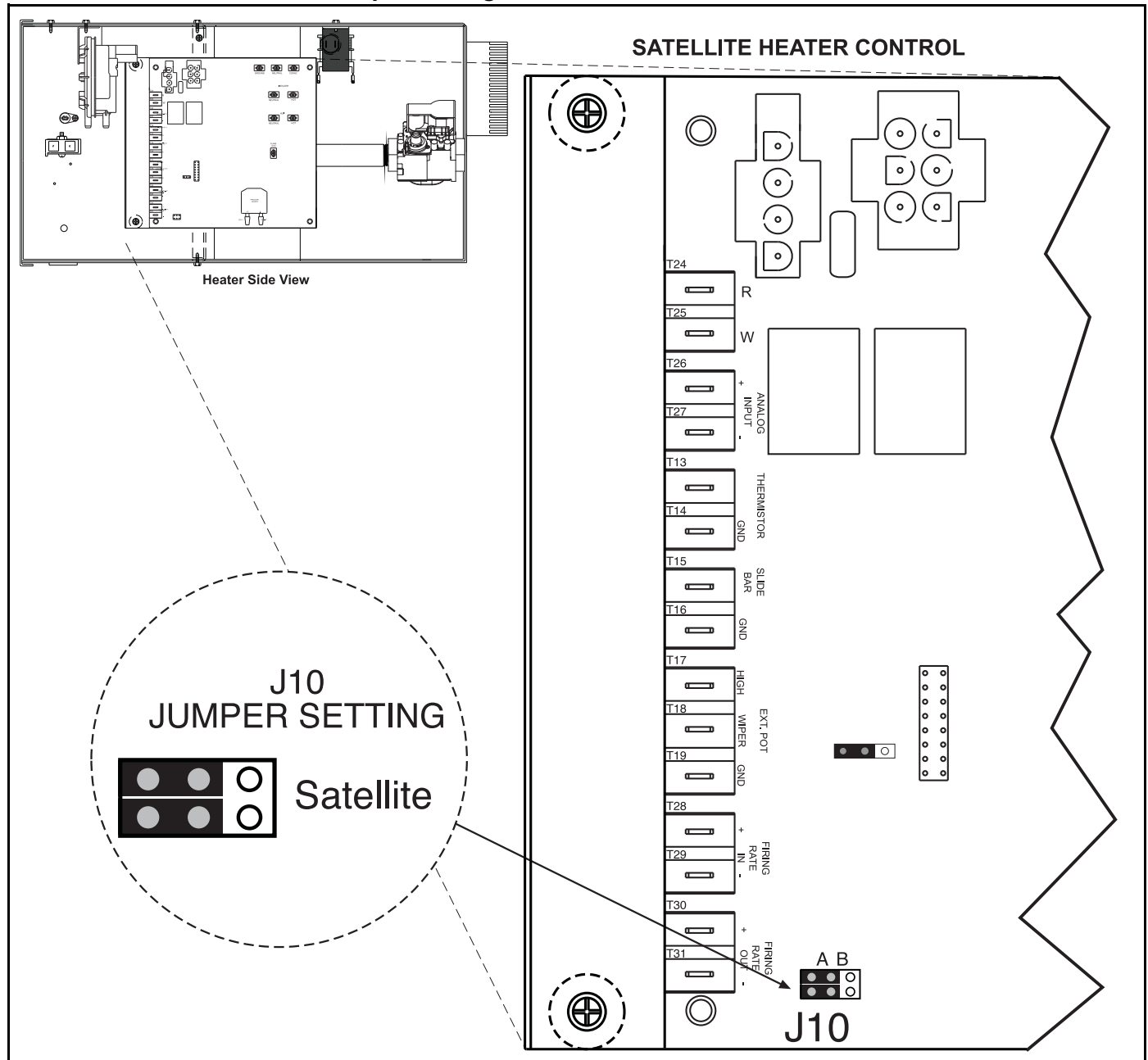
**FIGURE 26: Central Heater Jumper Settings**



### 10.2.2 Satellite Heater Configuration

Satellite heater configuration is set by positioning of jumpers on pin block J10 located on the control board inside the heater compartment, See Page 47, Figure 27. Jumper position on J10, shown on Page 47, Figure 27 will configure heater as a satellite heater. (The jumper position for satellite is the same as the jumper position of a central heater using a zone sensor). Jumper on J9 may be left alone.

**FIGURE 27: Satellite Heater Jumper Setting**

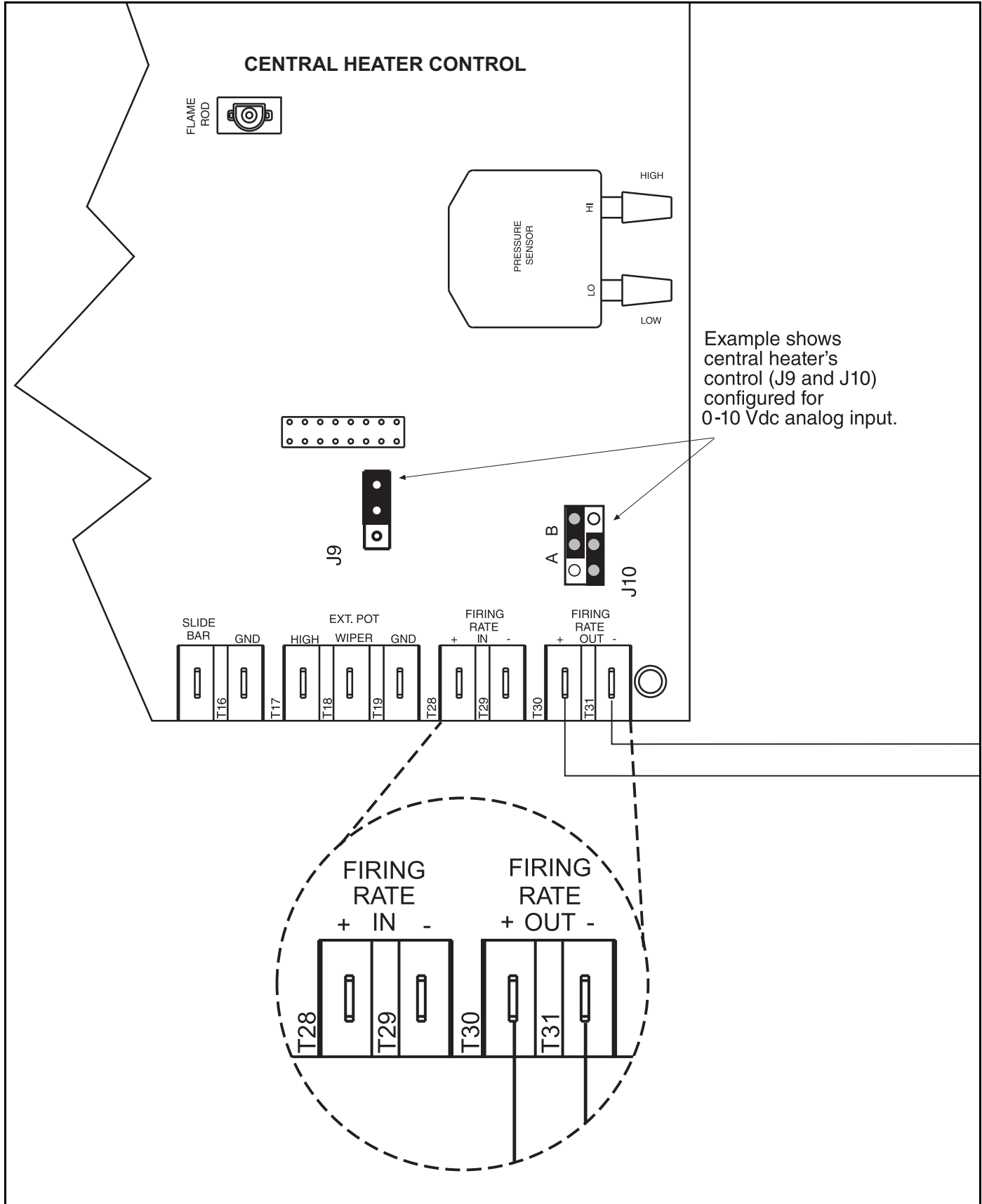


### 10.3 Communication Wiring within a Zone of Heaters

Satellite heaters will be wired in series to the central heater via low voltage control wiring.

Communication wiring uses the T28-T31 terminals on the control, see *Page 48, Figure 28*.

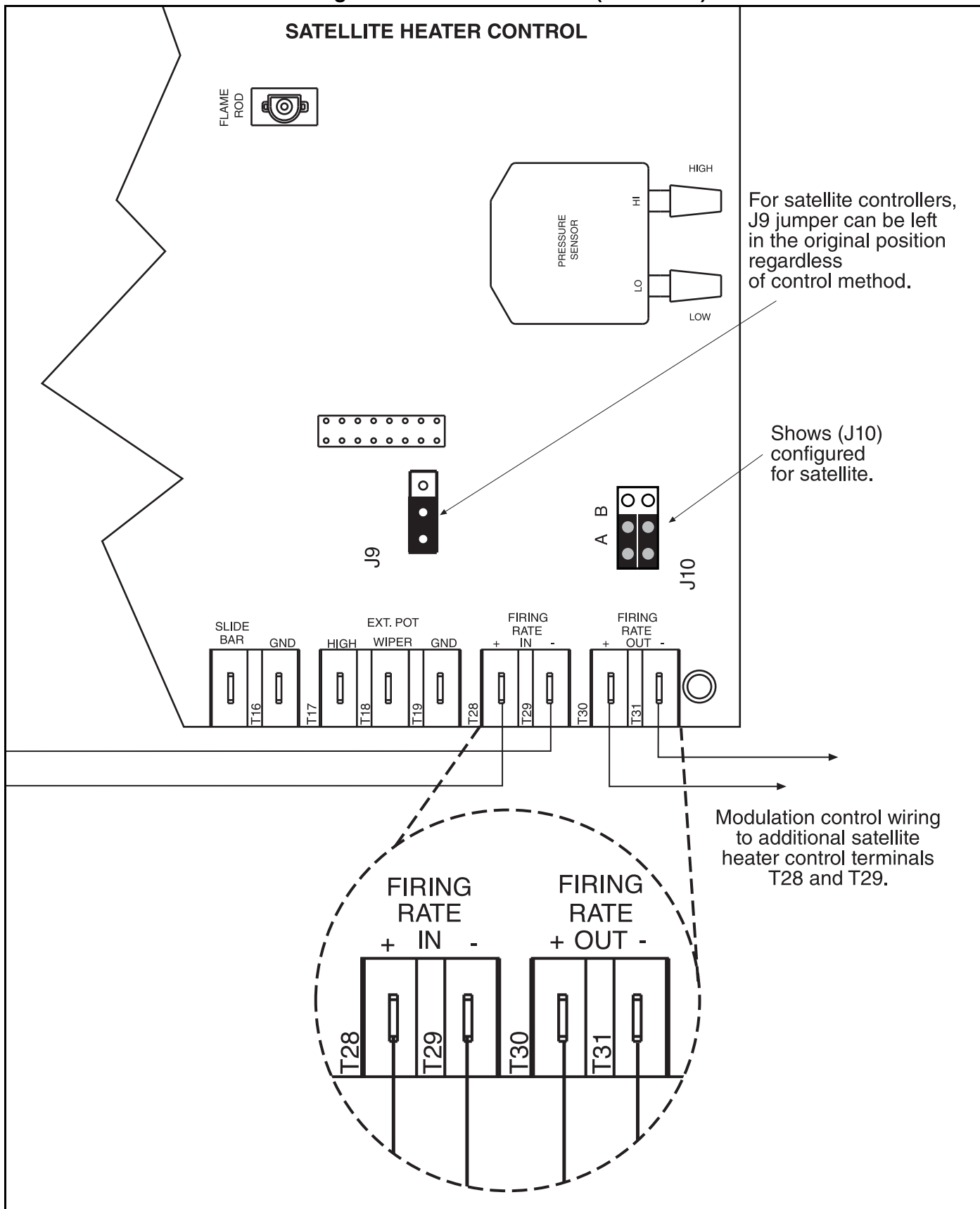
**FIGURE 28: Communication Wiring within a Zone of Heaters**



**10.3 Communication Wiring within a Zone of Heaters (continued)**

Satellite heaters will be wired in series to the central heater via low voltage control wiring. Communication wiring uses the T28-T31 terminals on the control, See Page 48 through Page 49, Figure 28.

**FIGURE 28: Communication Wiring within a Zone of Heaters (continued)**



### 10.4 Heat Demand Control Wiring

The heater input can be controlled by any one of the following heat demand control devices (control devices are wired to central heaters only):

#### 10.4.1 Zone Sensor

The zone sensor (P/N 10081530) offers automatic control of heater input. Heater(s) modulates based on difference between sensed air temperature and the temperature setpoint. Heater modulation in response to air temperature changes is immediate. Setpoint is adjusted with the slide bar adjustment at the bottom of the sensor. ON/OFF switch (used to disable heater operation or reset heater from lockout) is located on the side of the sensor. See Page 45, Figure 25 for wiring details.

#### 10.4.2 Thermostat

A thermostat offers automatic control of heater input. The heater control is designed for use with a standard 2-wire or 4-wire low voltage electronic thermostat (not for use with thermostats that have a heat anticipator). Typical wiring connects the R and W wires to the heater control.

W wires to the heater control and does not connect the Y (cooling) and G (fan) wires to the heater control.

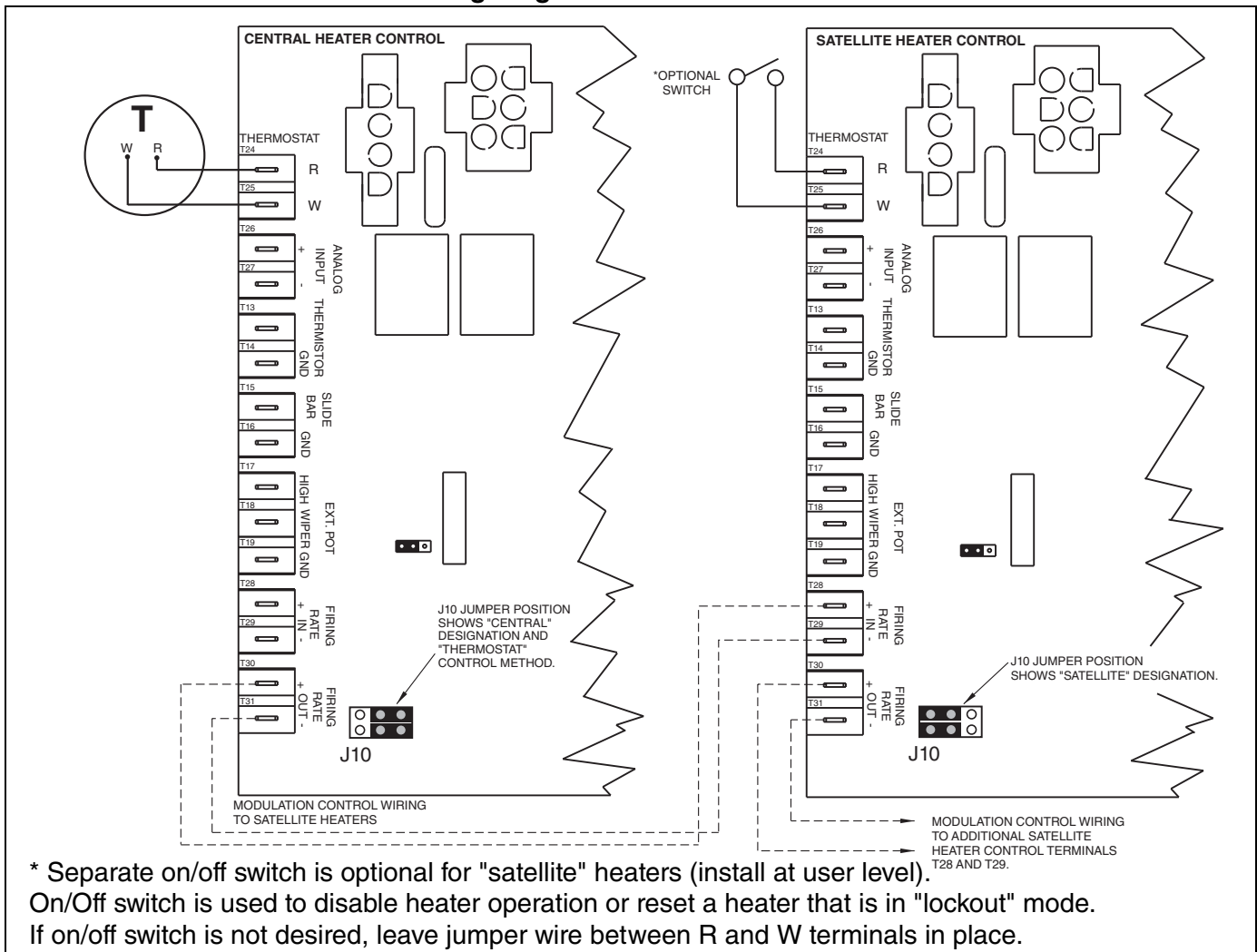
The heater can be used with thermostat, 24V (p/n 90425100) if set to 5 cycles per hour. Any other electronic thermostat without heat anticipator can be used if set to 5 or 6 cycles per hour.

On the control, the T24 and T25 (R and W) terminals supply 24 V to power an electronic thermostat. See Page 50, Figure 29 for wiring details. Consult the factory for other thermostat wiring configurations.

Heater(s) modulates based on heater and thermostat cycle timing, history and desired setpoint by using a pre-programmed algorithm. When using thermostat control, heater modulation response to rapid air temperature change is not immediate. Thermostat control is not recommended for use in areas with frequent or high air changes.

It is important to note that during normal operation, heater cycle continues beyond meeting thermostat setpoint.

**FIGURE 29: Thermostat Control Wiring Diagram**



### 10.4.3 Analog Signal Modulating Thermostat (P/N 90425105)

A programmable, 7-day programming, modulating thermostat can be installed to supply an analog (4-20mA) or (2-10Vdc with 500 Ohm resistor) control signal to dictate the heater(s) firing rate. The thermostat shall energize the T24 and T25 (R and W) terminals. For thermostat wiring, See *Page 55, Figure 32* and *Page 56, Figure 33*. Optional room sensors (P/N 10081520) and outdoor air sensors (P/N 10081521) are available.

Room temperature averaging networks can be created with up to nine room sensors (P/N 10081520). Refer to thermostat installation instructions for wiring.

### 10.4.4 Analog Signal Modulating Thermostat with LonWorks® Communication (P/N 90425104)

If LonWorks® communication is required, a modulating thermostat can be installed to supply an analog (4-20mA or 2-10Vdc) signal to control the heater(s) firing rate. For thermostat wiring, See *Page 55, Figure 32* and *Page 56, Figure 33*. Optional room sensors (P/N 10081520) and outdoor air sensors (P/N 10081521) are available for this thermostat, as well.

The modulating thermostat with LonWorks® provides networking capability in a LonWorks® system. Communications port running at 78 kilobits per second (kbs), this thermostat can be configured to perform a variety of activities in which data is sent or received on the LonWorks®. Information that can be shared, viewed and modified with network includes:

- Current year, month, day, hour, minute, second.
- System Mode.
- Space Temperature
- Outdoor air temperature
- Current setpoint
- Occupied/Unoccupied schedule commands.
- Space Temperature

### 10.4.5 Analog signal Modulating with BACnet® Programmable Thermostat

If BACnet® communication is required, a BACnet® enabled modulating thermostat can be installed (provided by others) to supply an analog output (0-10VDC) signal control to dictate the heater(s) firing rate.

This thermostat is a flexible wall-mounted stand-alone control with combined controller/sensor. Temperature sensing is standard with optional humidity and motion sensing. BACnet® connections

allow integral peer to peer BACnet® MS/TP LAN network communications with configurable baud rates and can easily integrate with a building automation system.

### MS/TP Wiring

Connect the -A terminal in parallel with all other -A terminals on the network and the +B terminal in parallel with other +B terminals.

### 10.4.6 Sequence of Operation for Modulating Thermostats

The thermostat will control the heater(s) firing rate based on the demand signal communicated from thermostat program taking into account space temperature. The thermostat will energize T25 (W) terminal. At high heat, a demand signal will turn the heater(s) on at maximum heater(s) firing rate. Once the room temperature gets close to the thermostat set point, then the thermostat program will slow the heater(s) firing rate down until the room temperature reaches the thermostat set point.



### 10.4.7 Cable Termination

Table lists wiring types, sizes and distances for modulating thermostat with LonWorks® communication (P/N 90425104), modulating

thermostat without communication (P/N 90425105) and BACnet® programmable thermostat (provided by others)

**Table 6: Cable Requirements**

Wire Function	Recommended Wire Size (Minimum)	Specification or Requirement	Distance (Maximum)
Digital Outputs	18 AWG (0.75 sq mm)	Standard thermostat wire	1000 ft (304 m)
Modulating Outputs	18 AWG (0.75 sq mm)	1 pair	500 ft (152 m)
Outdoor Air Temperature Sensor	18 AWG (0.75 sq mm)	1 pair	500 ft (152 m)
Remote Sensor	18 to 22 AWG (0.75 to 0.34 sq mm)	Twisted pair wire	1000 ft (304 m)
Power Wiring	18 to 14 AWG ( 0.75to 2.0 sq mm)	NEC Class II 140°F (60°C )	Limited by line-loss effects on power consumption.
LonWorks® (P/N 90424104 only)	18 AWG (0.75 sq mm) nonshielded	1 pair	Refer to E-bus Wiring Guide 74-2865 for maximum length and generic cable specifications.
MS/TP (provided by others)	18 AWG (0.75 sq mm) Shield	Belden cable #82760 or equivalent	Refer to Thermostat Installation Guide

### Power Requirements

Modulating thermostats require 24 volts, AC power.

### 10.4.8 Remote Analog Signal

Remote Analog Signal 0-10 Vdc or 4-20mA output from external controller or Building Management System (BMS) directly dictates heater(s) firing rate. An algorithm must be programmed into the BMS or external controller to receive zone air temperature signals from its own temperature sensors and then deliver an output signal to the heater(s) for the desired firing rate.

For 0-10Vdc control of the heater(s) firing rate, the following control conditions apply:

ON/OFF relay at the external controller or BMS must be wired to R and W terminals on the heater control board to turn the heater ON and OFF.

Minimum rated input at 1% of signal (0-1Vdc).

Full rated input at 90% of signal (9Vdc).

Input varies linearly between 1Vdc and 9Vdc.

**For 4-20mA control of the heater(s) firing rate, the following control conditions apply:**

ON/OFF relay at the external controller or BMS must be wired to R and W terminals on the heater control board to turn the heater ON and OFF.

(Open Circuit = OFF, Closed Circuit = ON).

Minimum rated input at 1% of signal (0-4 mA).

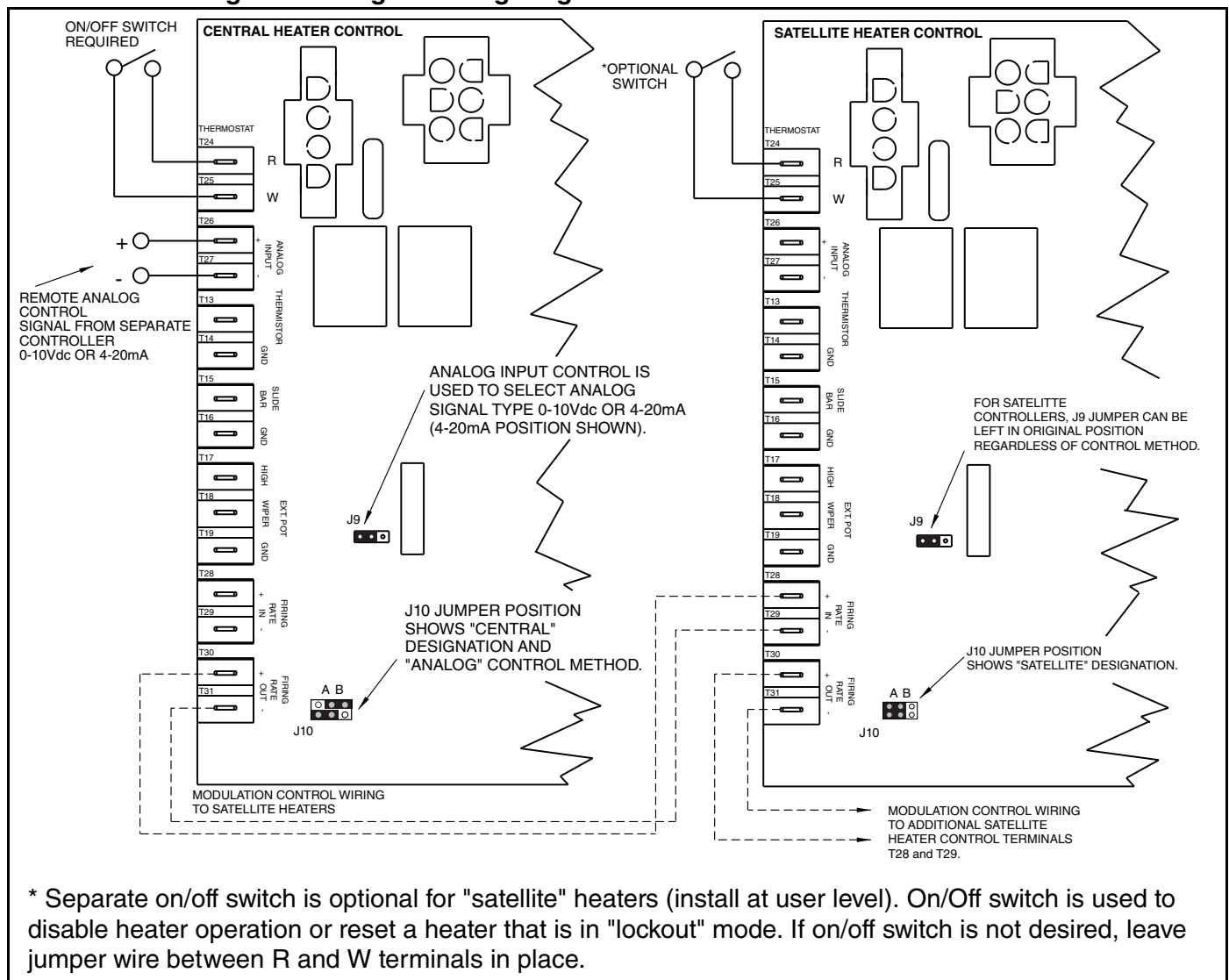
Full rated input at 90% of signal (18 mA).

Input varies linearly between 4 mA and 18 mA.

BMS controllers often offer PID loop control that can optimize output signal and rate of change of the output signal. Common analog application is defined as follows:

1. BMS sensors that monitor zone air temperatures are located in the heating space.
2. Based on sensed temperatures, the BMS will output an analog signal for the desired heater(s) firing rate.
3. As heater(s) receive the analog signal from the BMS, the heater(s) modulate to the corresponding firing rate.
4. As sensed air temperature rises closer to the desired temperature setpoint, the BMS will reduce the output signal, in turn reducing heater firing rate.
5. Upon satisfying temperature setpoint, the BMS will either:
  - a. Turn off the heater.
  - b. Reduce the signal so that the minimum heater firing rate is maintained until the sensed temperature rises above the setpoint to a cut-off limit temperature when the BMS turns off the heater.

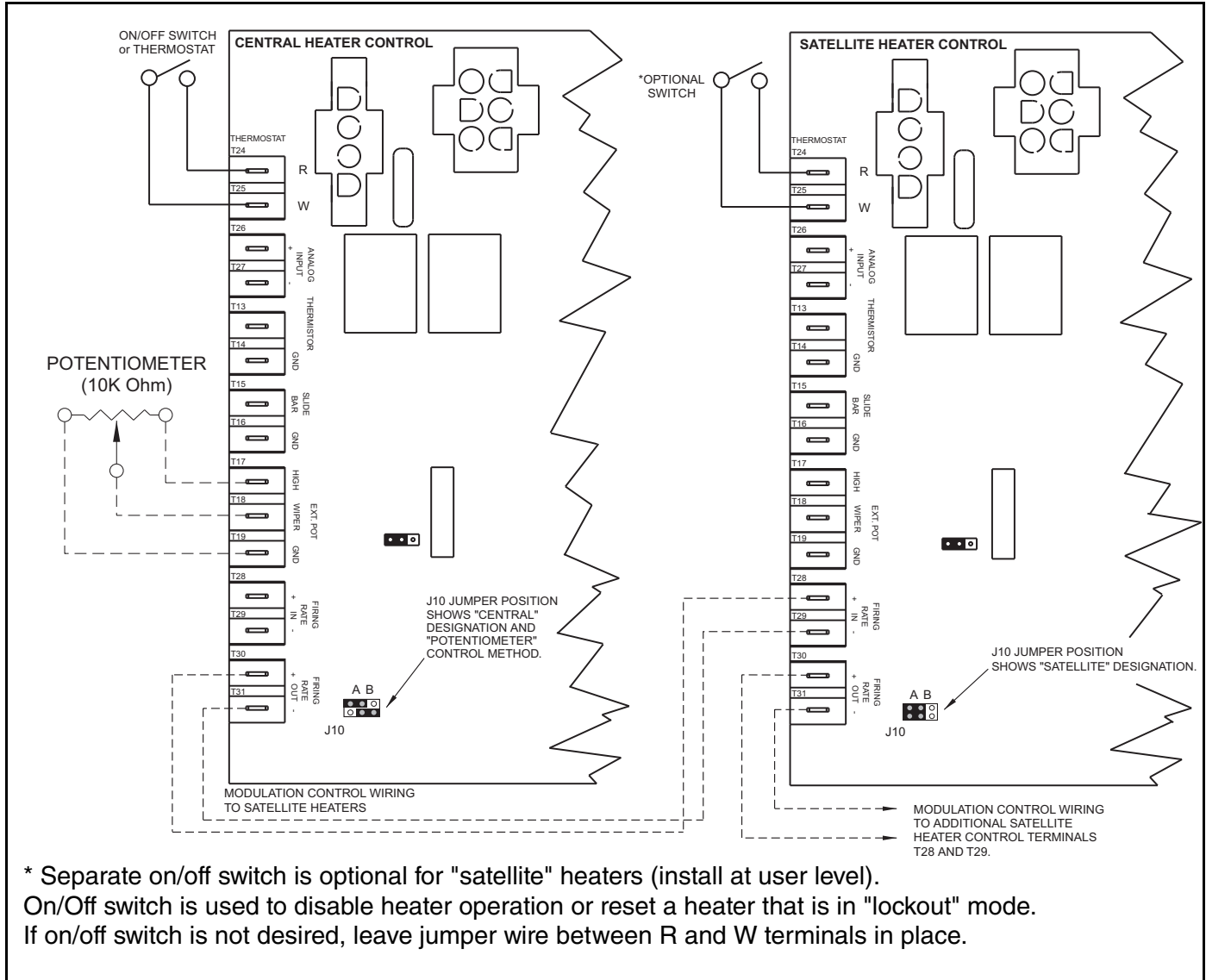
**FIGURE 30: Analog Control Signal Wiring Diagram**



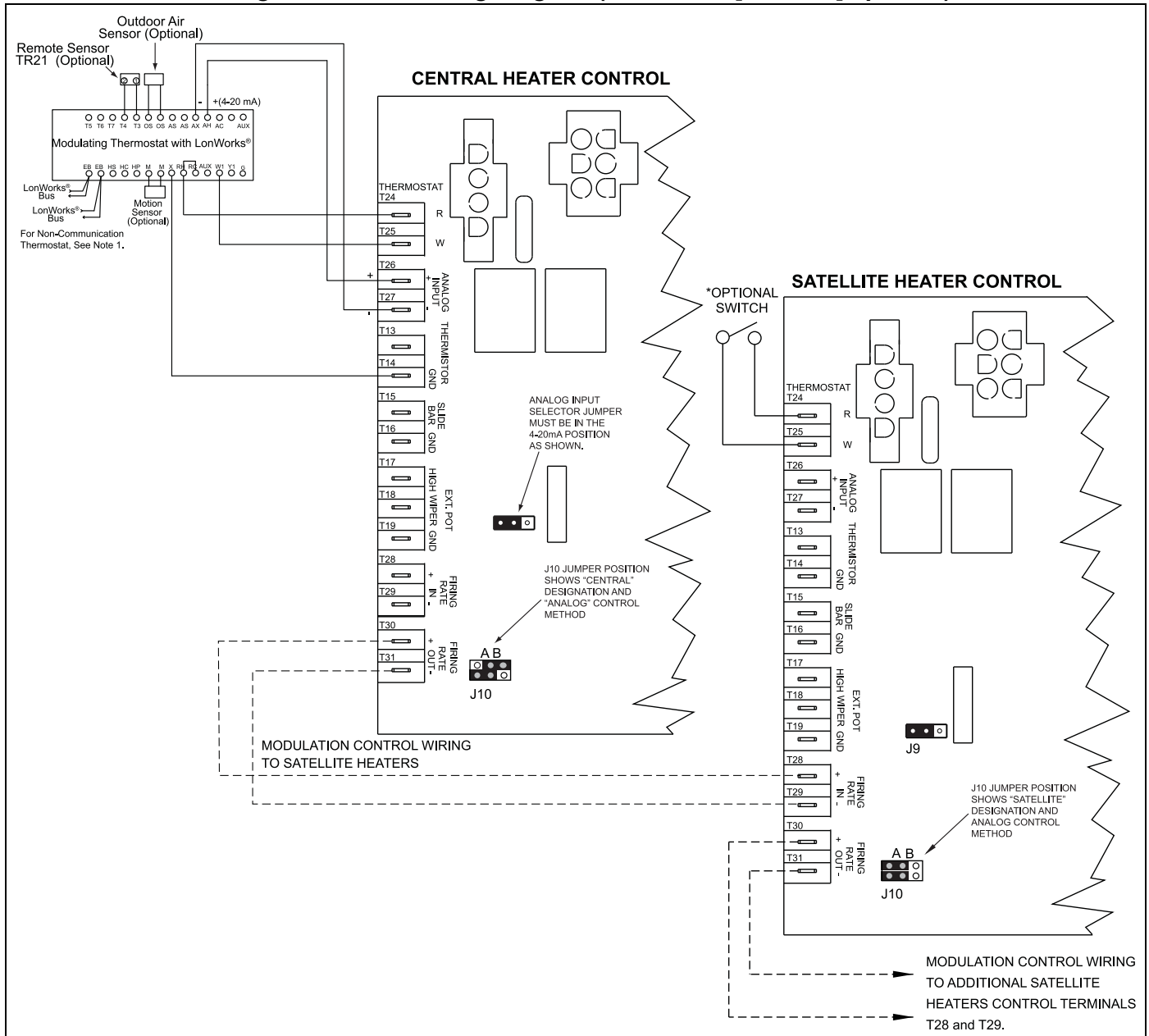
### 10.4.9 Potentiometer Control Device

Potentiometer (10K Ohm "Linear Taper") device offers manual control over heater(s) firing rate. This type of potentiometer can be found at a typical electrical supply retailer. Potentiometer dial position directly dictates heater(s) firing rate. Dial positions range between "Min" and "Max". Minimum and maximum heater firing rates (inputs) are marked on the heater's rating plate. ON/OFF switch or thermostat is used to disable heater operation or reset heater from lockout.

**FIGURE 31: Potentiometer Control Wiring Diagram**



**FIGURE 32: Modulating Thermostat Wiring Diagram (LonWorks® [4-20 mA] optional)**

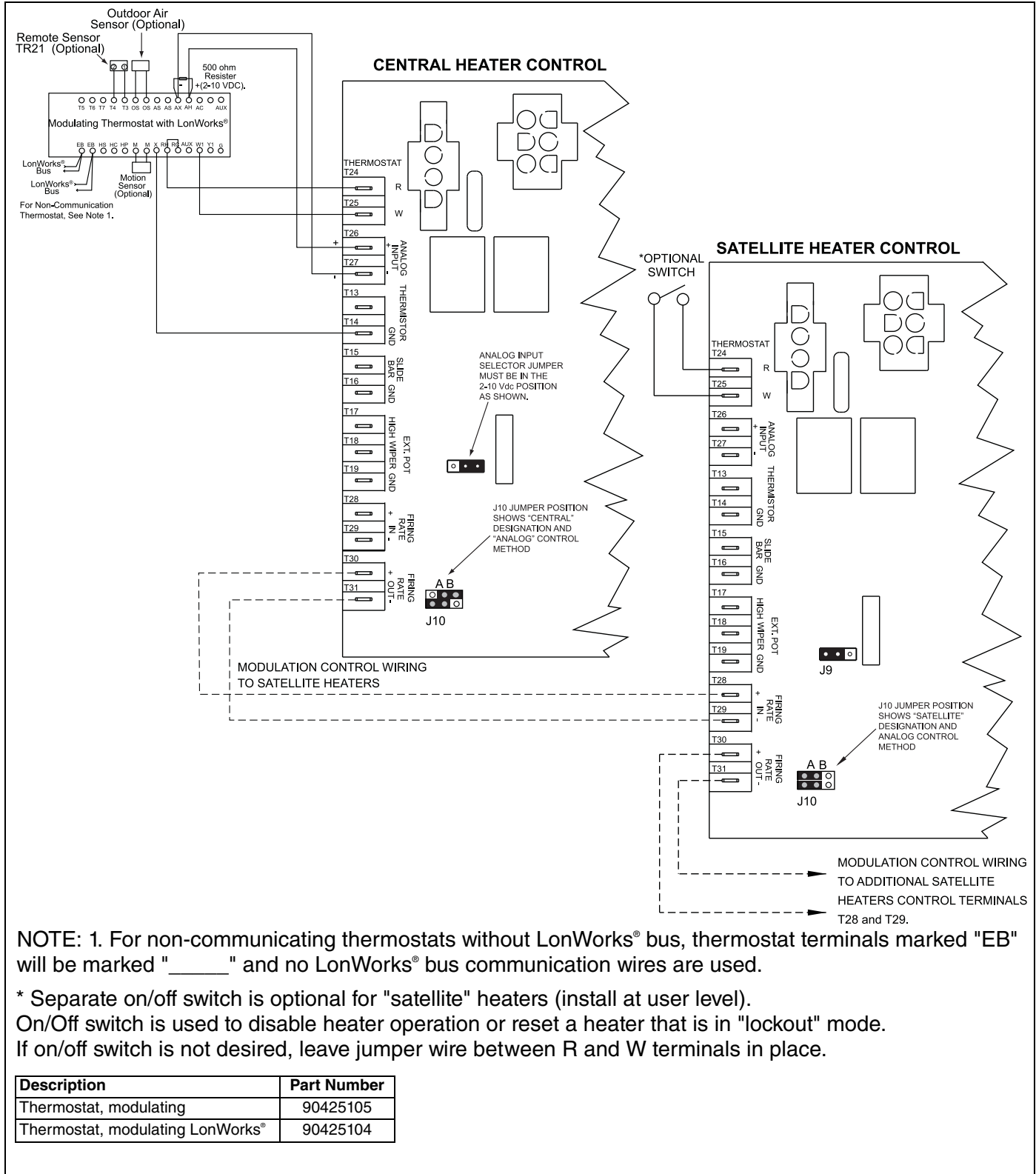


NOTE: 1. For non-communicating thermostats without LonWorks® bus, thermostat terminals marked "EB" will be marked "\_\_\_\_\_" and no LonWorks® bus communication wires are used.

\* Separate on/off switch is optional for "satellite" heaters (install at user level). On/Off switch is used to disable heater operation or reset a heater that is in "lockout" mode. If on/off switch is not desired, leave jumper wire between R and W terminals in place.

Description	Part Number
Thermostat, modulating	90425105
Thermostat, modulating LonWorks®	90425104

**FIGURE 33: Modulating Thermostat Wiring Diagram (LonWorks® [2-10Vdc with 500 Ohm resistor] optional)**



NOTE: 1. For non-communicating thermostats without LonWorks® bus, thermostat terminals marked "EB" will be marked "\_\_\_\_\_" and no LonWorks® bus communication wires are used.

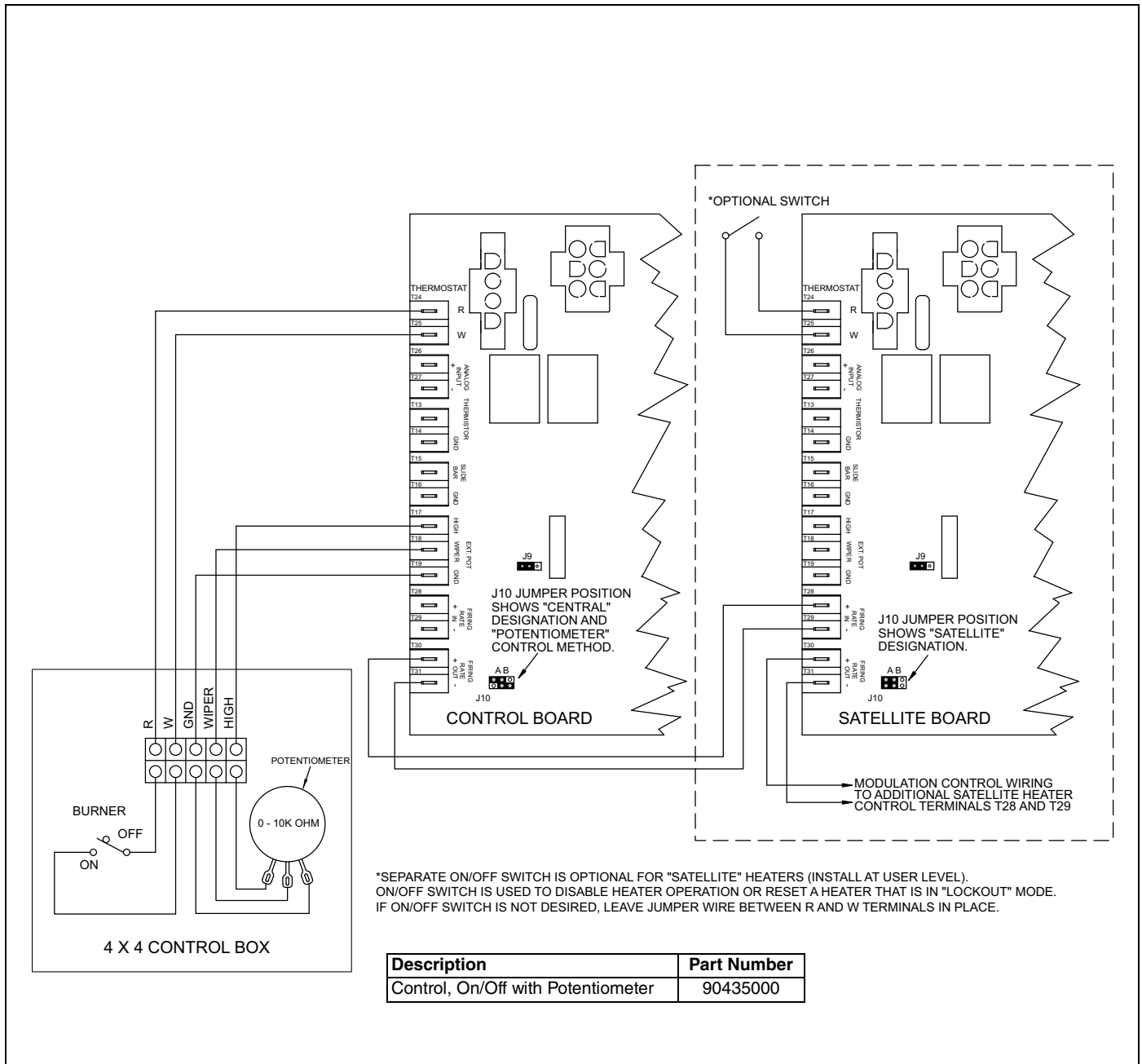
\* Separate on/off switch is optional for "satellite" heaters (install at user level). On/Off switch is used to disable heater operation or reset a heater that is in "lockout" mode. If on/off switch is not desired, leave jumper wire between R and W terminals in place.

Description	Part Number
Thermostat, modulating	90425105
Thermostat, modulating LonWorks®	90425104

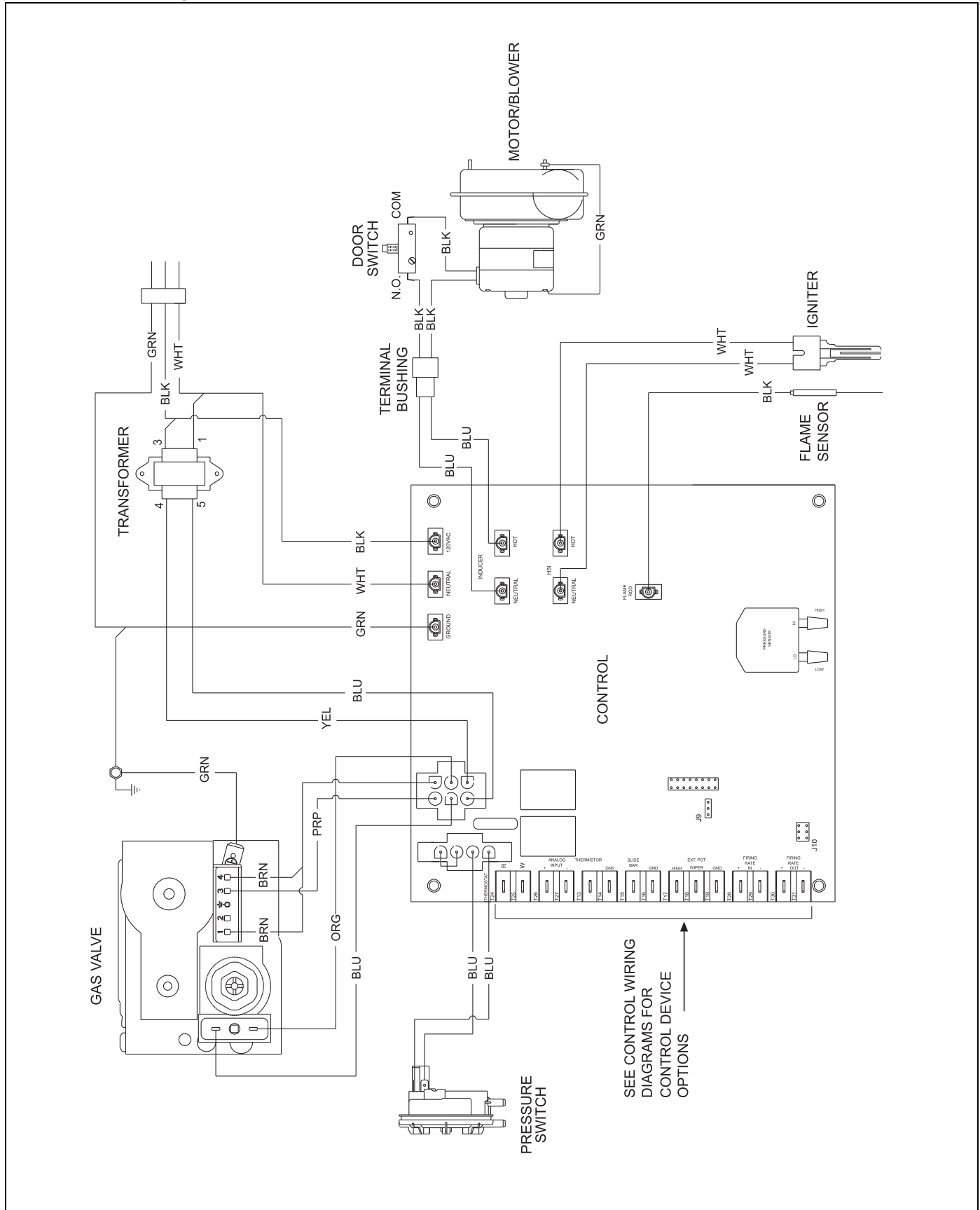
### 10.5 Potentiometer with On/Off Control

Potentiometer on/off control (10K Ohm "Linear Taper") offers manual control over heater(s) firing rate. Potentiometer dial position directly dictates heater(s) firing rate. Dial positions range between

"Min" and "Max". Minimum and maximum heater firing rates (inputs) are marked on the heater's rating plate. ON/OFF switch is used to disable heater operation or reset heater from lockout.

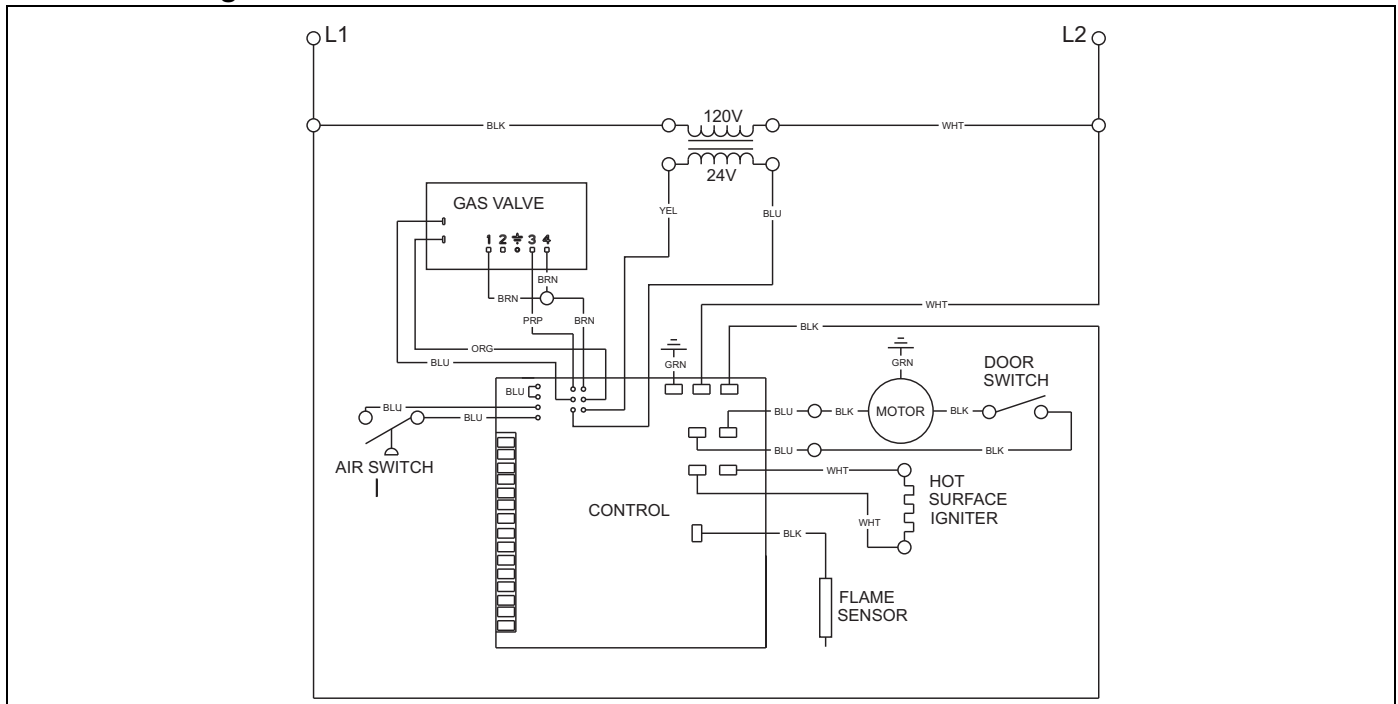


### 10.6 Internal Wiring



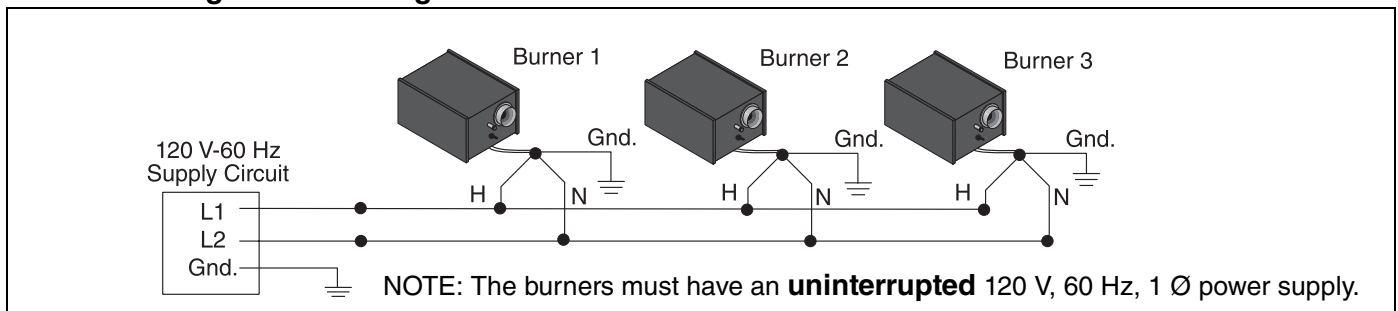
See Page 45, Section 10.1 through Page 54, Section 10.4.9 for temperature control device options and wiring schematic.

## 10.7 Ladder Diagram



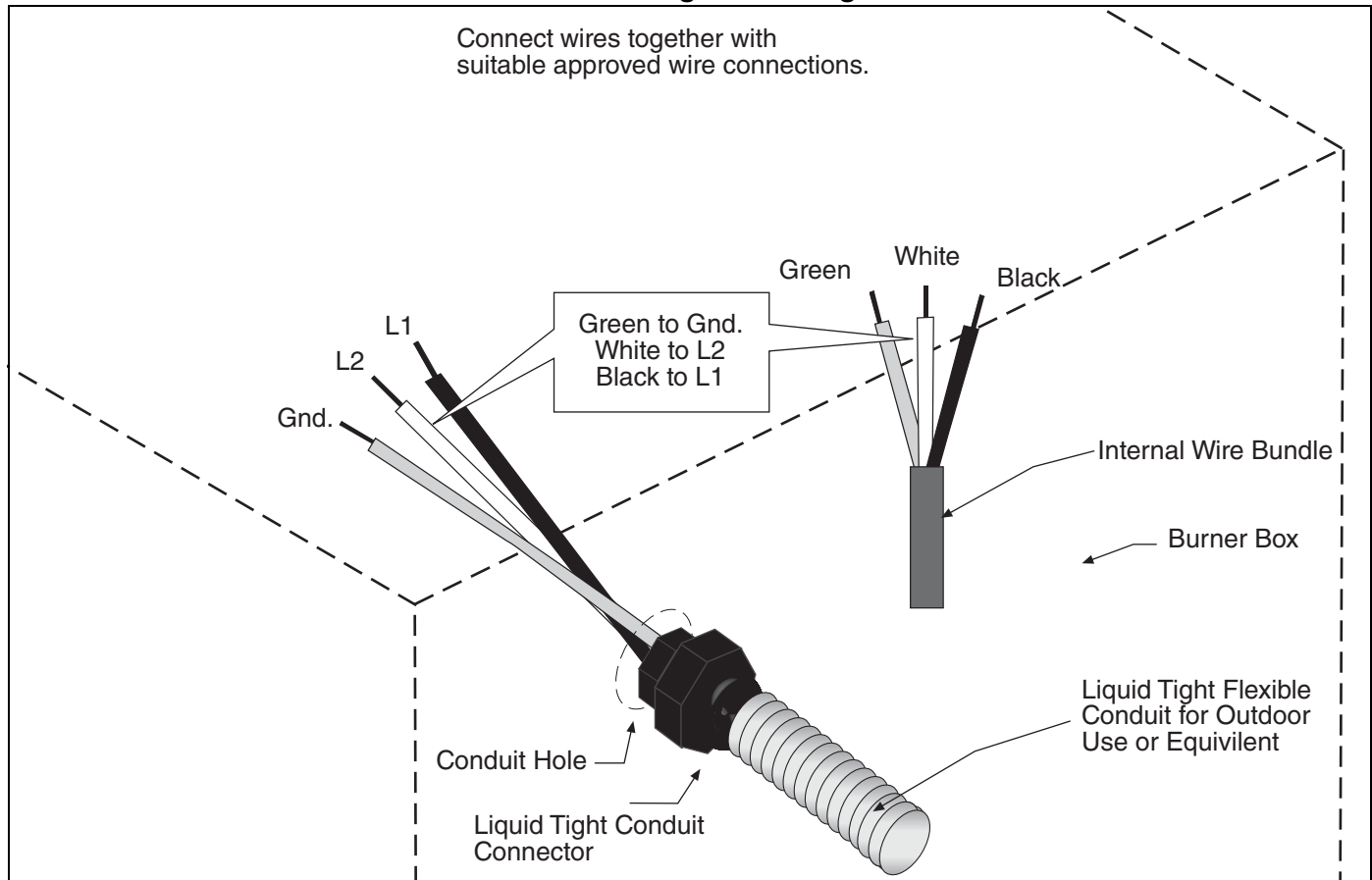
See Page 45, Section 10.1 through Page 54, Section 10.4.9 for temperature control device options and wiring schematic.

## 10.8 Line Voltage Power Wiring

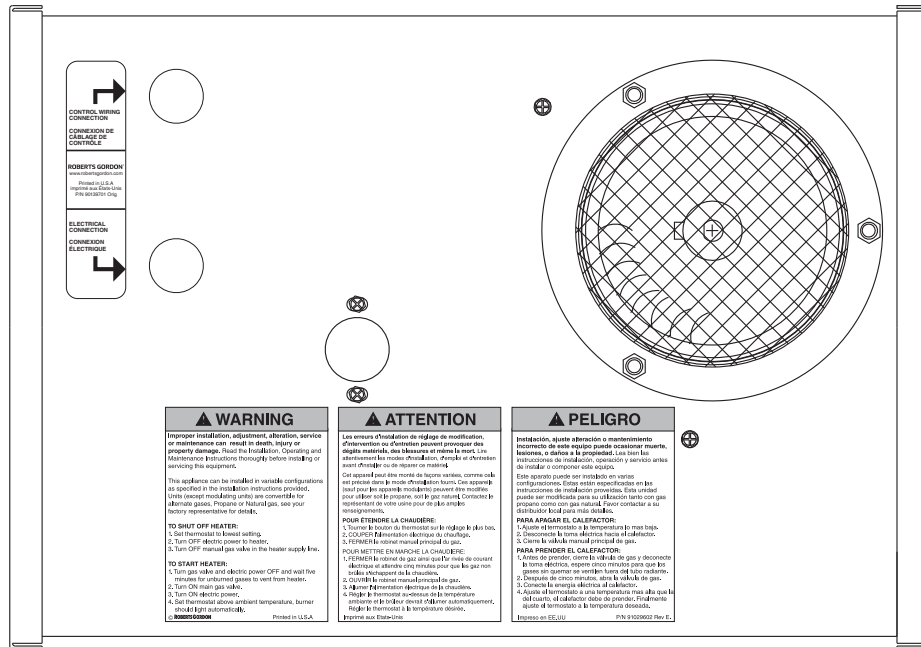




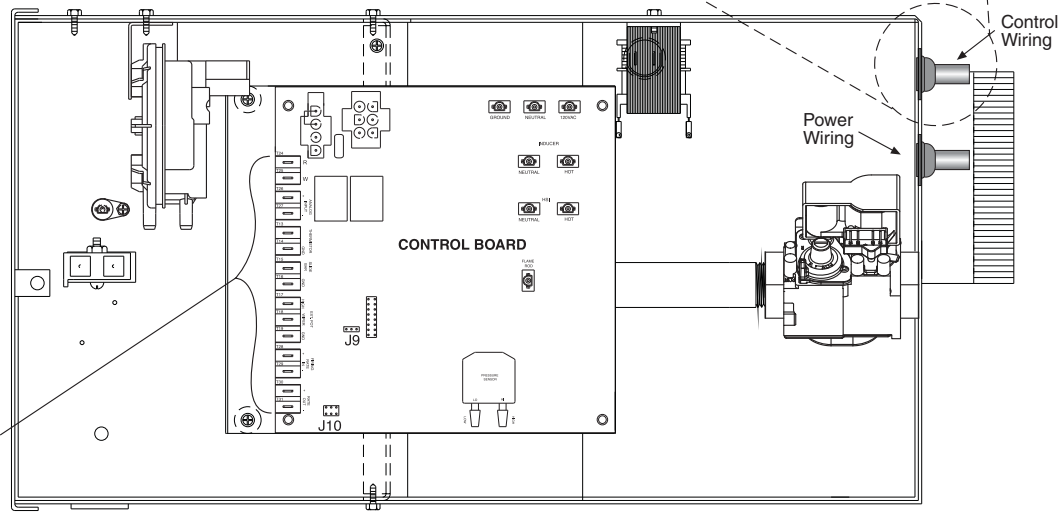
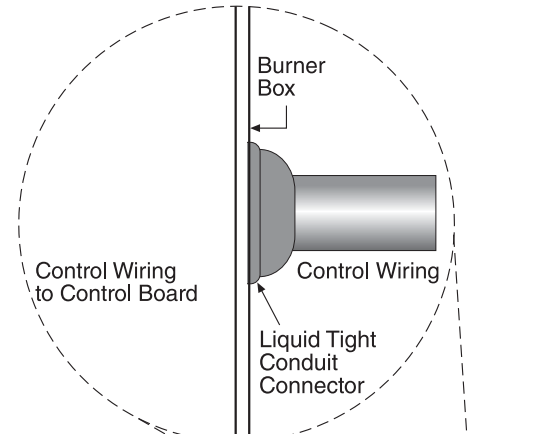
### 10.9 Electrical Connection to the Burner Box using Line Voltage Thermostat on Control



### 10.10 Low Voltage Control Wiring Installation



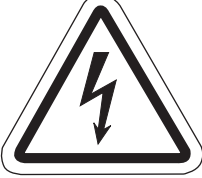



Heater Back View



Heater Side View

Description	Part Number
Cable Grommet with Tie	91309605

**SECTION 11: OPERATION AND MAINTENANCE**

<b>⚠ DANGER</b>		<b>⚠ WARNING</b>	
			
<p><b>Electrical Shock Hazard</b></p> <p>Disconnect electric before service.</p> <p>Heater must be connected to a properly grounded electrical source.</p>	<p><b>Explosion Hazard</b></p> <p>Turn off gas supply to heater before service.</p>	<p><b>Burn Hazard</b></p> <p>Allow heater to cool before service.</p> <p>Tubing may still be hot after operation.</p>	<p><b>Cut/Pinch Hazard</b></p> <p>Wear protective gear during installation, operation and service.</p> <p>Edges are sharp.</p>
<p><b>Failure to follow these instructions can result in death, electric shock, injury or property damage.</b></p>			

**11.1 Sequence of Operation**

The control inside the heater's control compartment is equipped with a tri-color LED. The LED offers comprehensive diagnostic capability. The LED status will be referenced throughout this section.

1. When the control is powered and there is no call for heat from external heat demand device, the LED on the control flashes slow green; LED is ON for the same period it is OFF.
2. On a call for heat from the heat demand device, the heater will go to PRE-PURGE. The LED indicates one green flash. The blower speed will vary as the pressure switch setpoints are verified. When the PRE-PURGE is successfully completed, the heater will go into the PRE-IGNITION state and power the hot surface igniter (H.S.I.).
3. After the igniter warms up, the heater will go to the IGNITION state. Power is supplied to the gas valve operator, gas flows, ignites and the flame is proven. The LED shows two green flashes on the LED. If a flame is not sensed, the heater will RETRY, See *Item 6* below for further details.
4. When the IGNITION state is completed, the heater will go to WARM UP state. The unit will fire at maximum input for 15 seconds. When the WARM UP state is completed the device will go into RUN state. The control board will monitor the heat demand device and modulate the heater input to meet the demand. The LED still shows two green flashes.
5. When the call for heat has been satisfied, the heater closes the gas valve. The blower

continues to run for a 45 second post-purge period. After the post-purge, the heater turns OFF and the LED on the control board flashes slow green.

6. If flame is lost at any time during heater operation, the heater will RETRY for ignition. Upon RETRY the LED shows a fast yellow flash (LED rapidly flashes). The heater will RETRY for ignition three times. After four ignition attempts, the heater will lockout for one hour or until reset. To reset the heater, remove power for 10 seconds, then re-apply power. Turn heater ON with call for heat from the heat demand device.

**11.2 To Shut Off Heater**

- Set external heat demand device to lowest setting.
- Turn OFF electric power to heater.
- Turn OFF manual gas valve in the heater supply line.

**11.3 To Start Heater**

- Turn gas valve and electric power OFF and wait five minutes for unburned gases to vent from heater.
- Turn ON main gas valve.
- Turn ON electric power.
- Set heat demand device to desired temperature. Burner should light automatically.

**11.4 Pre-Season Maintenance and Annual Inspection**

- To ensure your safety and years of trouble-free operation of the heating system, service and annual inspections must be done by a contractor qualified in the installation and service of gas-fired heating equipment.
- Turn off gas and electric supplies before performing

service or maintenance. Allow heater to cool before servicing.

Before every heating season, a contractor qualified in the installation and service of gas-fired heating equipment must perform a thorough safety inspection of the heater.

For best performance, the gas, electrical, thermostat connections, tubing, venting, suspensions and overall heater condition should be thoroughly inspected.

**NOTE:** Gas flow and burner ignition are among the first things that should be inspected.

Please See *Page 63* for suggested items to inspect.

#### **Installation Code and Annual Inspections:**

All installation and service of ROBERTS GORDON® equipment must be performed by a contractor qualified in the installation and service of equipment sold and supplied by Roberts-Gordon LLC and conform to all requirements set forth in the ROBERTS GORDON® manuals and all applicable governmental authorities pertaining to the installation, service, operation and labeling of the equipment.

To help facilitate optimum performance and safety, Roberts-Gordon LLC recommends that a qualified contractor conduct, at a minimum, annual inspections of your ROBERTS GORDON® equipment and perform service where necessary, using only replacement parts sold and supplied by Roberts-Gordon LLC.





<b>The Vicinity of the Heater</b>	<p>Do not store or use flammable objects, liquids or vapors near the heater. Immediately remove these items if they are present.</p> <p><i>See Page 5, Section 3.</i></p>
<b>Vehicles and Other Objects</b>	<p>Maintain the clearances to combustibles.</p> <p>Do not hang anything from, or place anything on, the heater.</p> <p>Make sure nothing is lodged underneath the reflector, in between the tubes or in the decorative or protective grilles (included with select models).</p> <p>Immediately remove objects in violation of the clearances to combustibles.</p> <p><i>See Page 5, Section 3.</i></p>
<b>Reflector</b>	<p>Support reflector with reflector hanger and support strap.</p> <p>Reflector must not touch tube.</p> <p>Make sure there is no dirt, sagging, cracking or distortion.</p> <p>Do not operate if there is sagging, cracking or distortion.</p> <p>Make sure reflectors are correctly overlapped. <i>See Page 24, Section 6.6.1.</i></p> <p>Clean outside surface with a damp cloth.</p>
<b>Vent Pipe</b>	<p>Venting must be intact. Using a flashlight, look for obstructions, cracks on the pipe, gaps in the sealed areas or corrosion.</p> <p>The area must be free of dirt and dust. Clean as required.</p> <p>Remove any carbon deposits or scale using a wire brush.</p> <p><i>See Page 35, Section 8.</i></p>
<b>Outside Air Inlet</b>	<p>Inlet must be intact. Look for obstructions, cracks on the pipe, gaps in the sealed areas or corrosion.</p> <p>The area must be free of dirt and dust. Clean and reinstall as required.</p>
<b>Tubes</b>	<p>Make sure there are no cracks.</p> <p>Make sure tubes are connected and suspended securely.</p> <p><i>See Page 15, Section 6.</i></p> <p>Make sure there is no sagging, bending or distortion.</p> <p>Clean or replace as required.</p>

<b>Gas Line</b>	Check for gas leaks. <i>See Page 43, Section 9.</i>
<b>Burner Observation Window</b>	Make sure it is clean and free of cracks or holes. Clean and replace as required.
<b>Blower Scroll, Wheel and Motor</b>	Compressed air or a vacuum cleaner may be used to clean dust and dirt.
<b>Burner Cup and Orifice</b>	Clear of obstructions (even spider webs will cause problems). Carefully remove any dust and debris from the burner.
<b>Hot-Surface Igniter</b>	Replace if cracked or broken.
<b>Heat Demand Device: Thermostat, Zone Sensor, External Pot or 0-10 Vdc or 4 - 20 mA wiring</b>	There should be no exposed wire or damage to the device or wiring. <i>See Page 45, Section 10.</i>
<b>Suspension Points</b>	Make sure the heater is hanging securely. Look for signs of wear on the chain or ceiling. <i>See Page 16, Figure 15.</i>
<b>Decorative and Protective Grille (optional)</b>	The grille must be securely attached. Check that the side reflector extensions are installed correctly and secured in place if necessary. (Decorative grille only.) <i>See Page 32, Section 7.5 and Page 34, Section 7.6</i> Make sure shield is installed correctly and secured in place if necessary. (Decorative grille only.) <i>See Page 33, Section 7.5.2.</i>
<b>Lower Clearance Shield (optional)</b>	The lower shield must be securely attached. Inspect shield support straps and lower clearance shield anchor points. <i>See Page 32, Section 7.4.</i> Make sure shield is installed correctly and secured in place if necessary. <i>See Page 32, Section 7.4.</i>
<b>Silicone Tubing</b>	Ensure tight, secure fit on all pressure fittings at gas valve, pressure switch, pressure sensor, burner partition, and blower outlet.
<b>Gas Valve</b>	Verify silicone tubing has a tight secure fit on "vent" fitting. Verify that plastic cap on covering pressure regulator adjustment screw is secure and has not been tampered with. Do not remove plastic regulator cap or attempt to adjust valve pressure regulator. Verify all wiring connections.
<b>Wall Tag</b>	If wall tag is present, make sure it is legible and accurate. Please contact Roberts-Gordon LLC or your ROBERTS GORDON® independent distributor, if you need a wall tag. <i>See Page 4, Section 2.1.</i>
<b>Safety Labels</b>	Product safety signs or labels should be replaced by the product user when they are no longer legible. Please contact Roberts-Gordon LLC or your ROBERTS GORDON® independent distributor to obtain replacement signs or labels. <i>See Page 2, Figure 1 through Page 3, Figure 2.</i>

## SECTION 12: TROUBLESHOOTING

<b>⚠ DANGER</b>

<b>Electrical Shock Hazard</b>
Disconnect electric before service.
More than one disconnect switch may be required to disconnect electric from heater.
Heater must be properly grounded.
Failure to follow these instructions can result in death or electrical shock.

<b>⚠ WARNING</b>			
			
<b>Fire Hazard</b>	<b>Explosion Hazard</b>	<b>Burn Hazard</b>	<b>Cut/Pinch Hazard</b>
Keep all flammable objects, liquids and vapors the minimum required clearances to combustibles away from heater.	Turn off gas supply to heater before service.	Allow heater to cool before service.	Wear protective gear during installation, operation and service.
Some objects will catch fire or explode when placed close to heater.		Tubing may still be hot after operation.	Edges are sharp.
<b>Failure to follow these instructions can result in death, injury or property damage.</b>			

**12.1 Control LED**

The control inside the heater's control compartment is equipped with a tri-color LED. The LED offers comprehensive diagnostic capability. The LED is showing some form of status signal at all times when the control is powered. The color of the LED differentiates normal from error conditions as follows:

GREEN indicates normal operation.

RED indicates an error condition.

YELLOW (fast flashing) indicates a RETRY attempt.

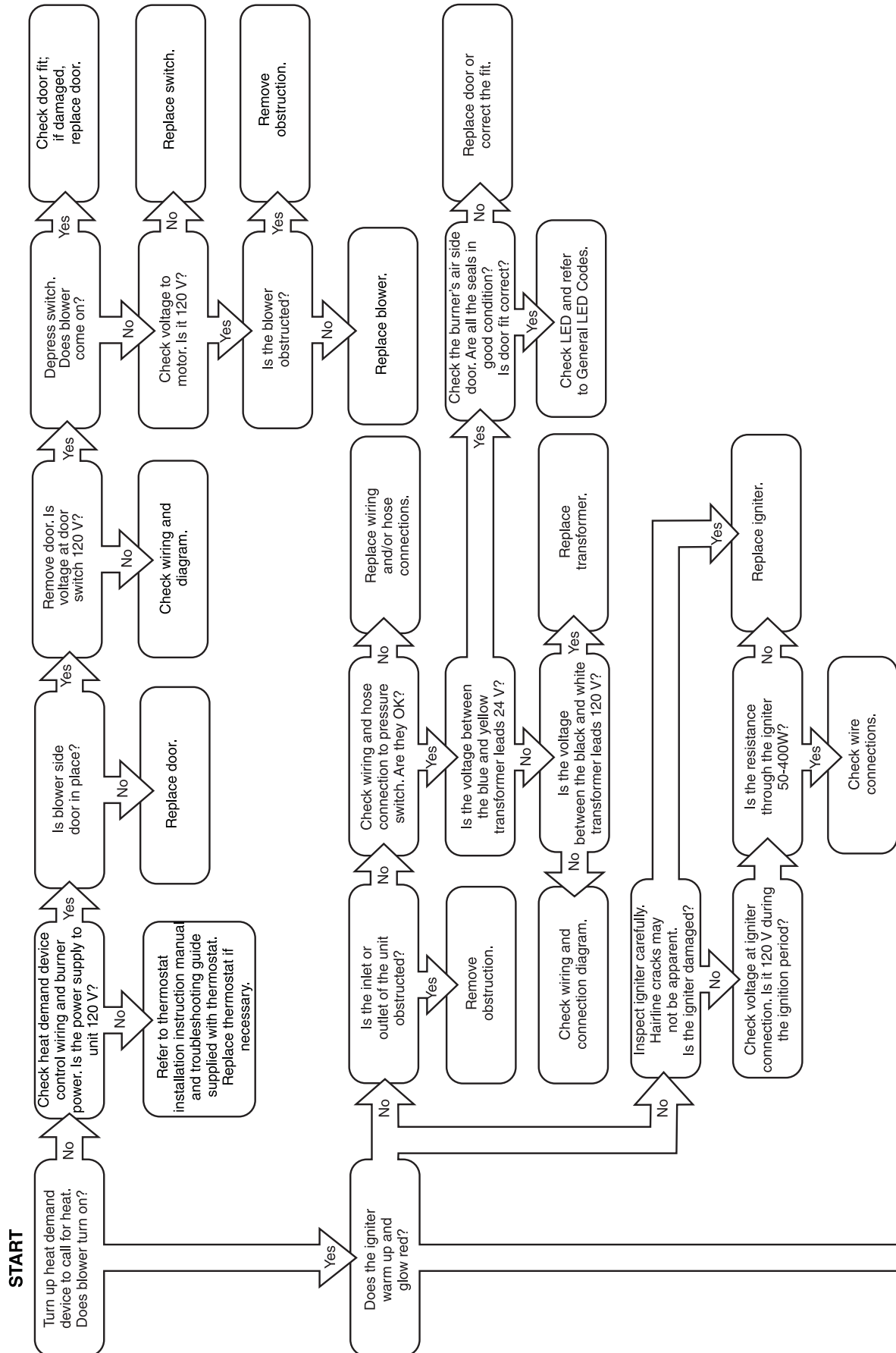
LED NOT LIT indicates no power to control.

**12.2 General LED Codes**

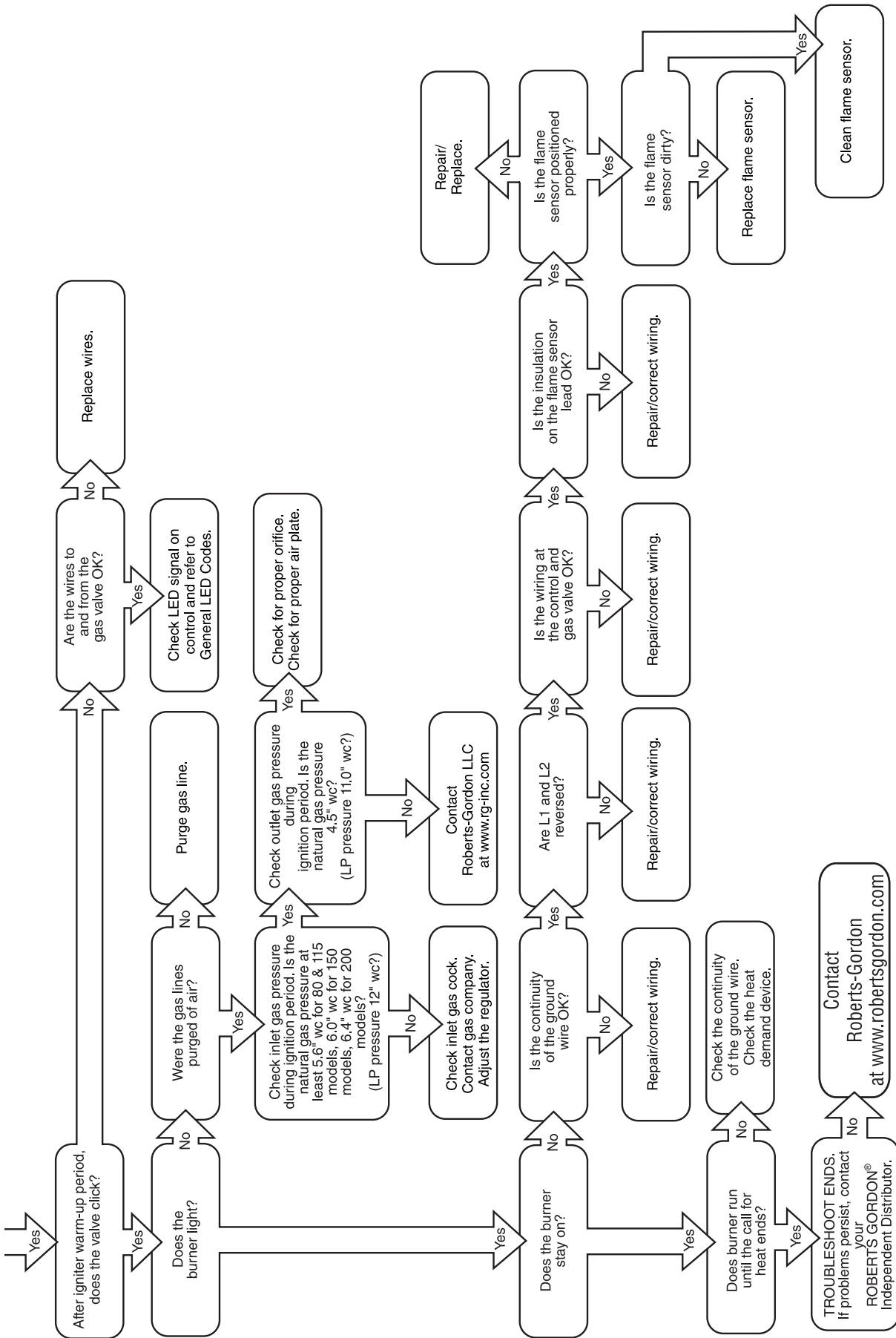
No LED:	No Power to control.
Slow Green:	LED slowly flashes on and off, indicates power to the control board but no call for heat.
GREEN, 1 flash:	Call for heat indicates the heater is performing the safe

	start pre-purge function or H.S.I. warm-up.		intake or exhaust vent.
GREEN, 2 flashes:	Call for heat indicates the heater is performing light off, heater warm-up, or heater run.	RED, 3 flashes:	Lockout- Flame is sensed on when it should be off or off when it should be on. Could be caused by: <ul style="list-style-type: none"> <li>• Flame Rod</li> <li>• H.S.I.</li> <li>• Gas Supply</li> <li>• 120 V Supply Polarity</li> <li>• Board Fault</li> </ul>
GREEN, 3 flashes:	*Only applicable for thermostat control* Gas ON - No call for heat, unit modulating from single stage thermostat.		
AMBER, 1 flash:	Call for heat when flame signal is below 1 $\mu$ A	RED, 4 flashes:	Lockout- Gas Valve. Condition caused by main valve on gas valve. Check gas valve wiring.
AMBER, 2 flashes:	Gas ON - Call for heat when flame signal is below 1 $\mu$ A	RED, 5 flashes:	Lockout- Board Failure. Board must be replaced.
AMBER, 3 flashes:	*Only applicable for thermostat control* Gas ON - No call for heat, unit modulating from single stage thermostat when flame signal is below 1 $\mu$ A.	RED, 6 flashes:	Not used.
		RED, 7 flashes:	Lockout- Fuse Open. Condition could be caused by: <ul style="list-style-type: none"> <li>• Fuse blown</li> <li>• High Limit Switch open a board location J3</li> </ul>
AMBER, Fast Flashing:	Heater is in RETRY mode.	RED, 8 flashes:	Lockout- Pressure switch failed to operate or modulation current was incorrect. Condition could be caused by: <ul style="list-style-type: none"> <li>• Pressure Sensor</li> <li>• Pressure Switch (faulty or hoses reversed)</li> <li>• Gas Valve Modulation Coil</li> <li>• Wire Harness (6 wire)</li> </ul>
RED Steady LED:	Control FAILURE, No 24 V power supply.		
RED, 1 flash:	Lockout- Insufficient sensed air pressure when blower is on. Condition could be caused by: <ul style="list-style-type: none"> <li>• Air Side Door</li> <li>• Blower</li> <li>• Obstruction in inlet or outlet</li> <li>• Pressure hose fittings</li> <li>• Pressure Switch</li> </ul>	RED, 9 flashes:	Lockout- Air Supply. Condition could be caused by: <ul style="list-style-type: none"> <li>• Blower</li> <li>• Pneumatic Connections to Pressure Sensor</li> <li>• Blockage in flue or inlet</li> </ul>
RED, 2 flashes:	Lockout- Blower air pressure reads above zero level when blower is off. Condition is caused by a pressure sensor failure or complete blockage of air		

## 12.3 Troubleshooting Flow Chart







### 12.4 Manifold Gas Pressure Measurement

**⚠ WARNING**

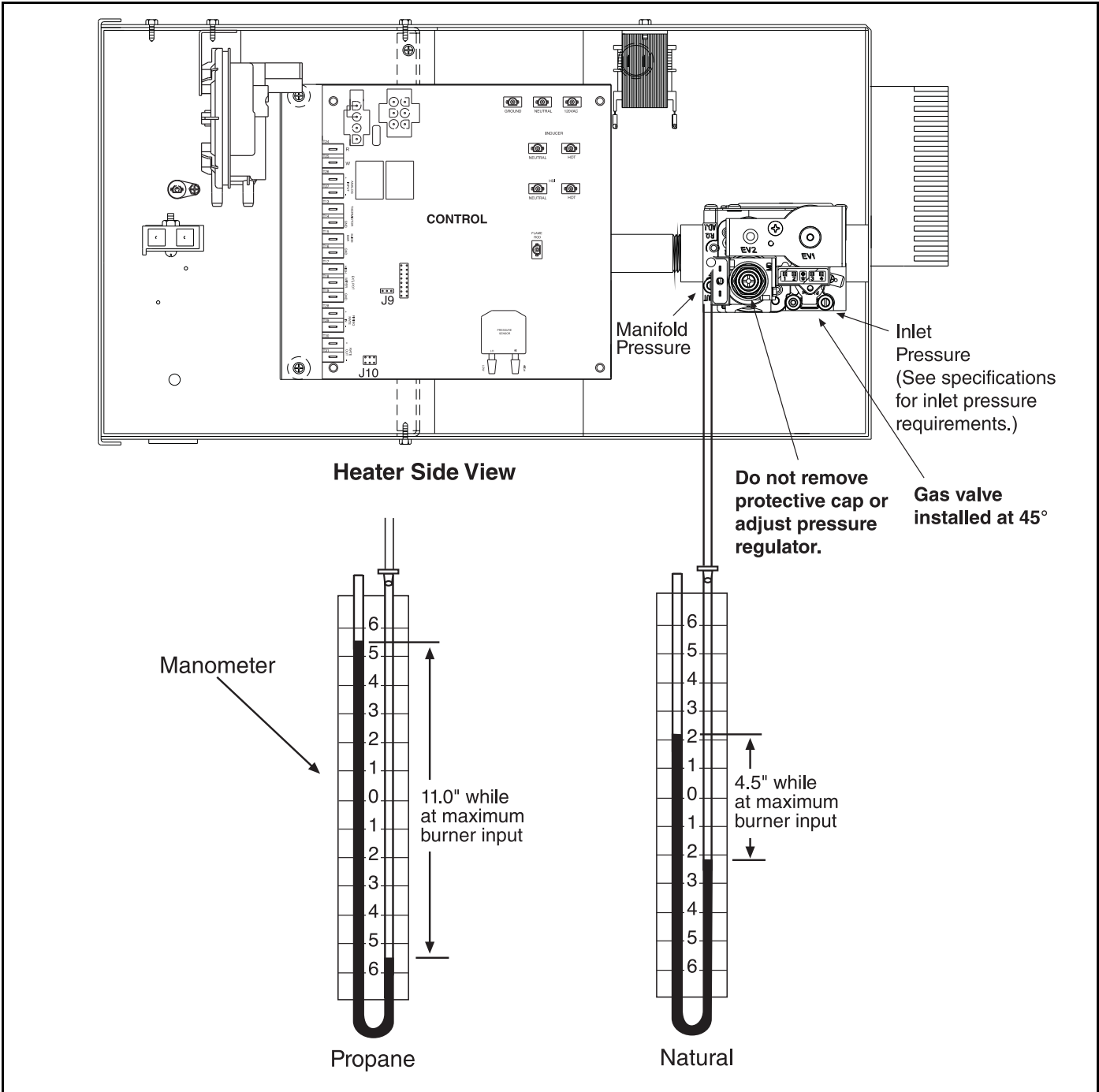

**Carbon Monoxide Hazard**

**Do not adjust gas valve pressure regulator.**

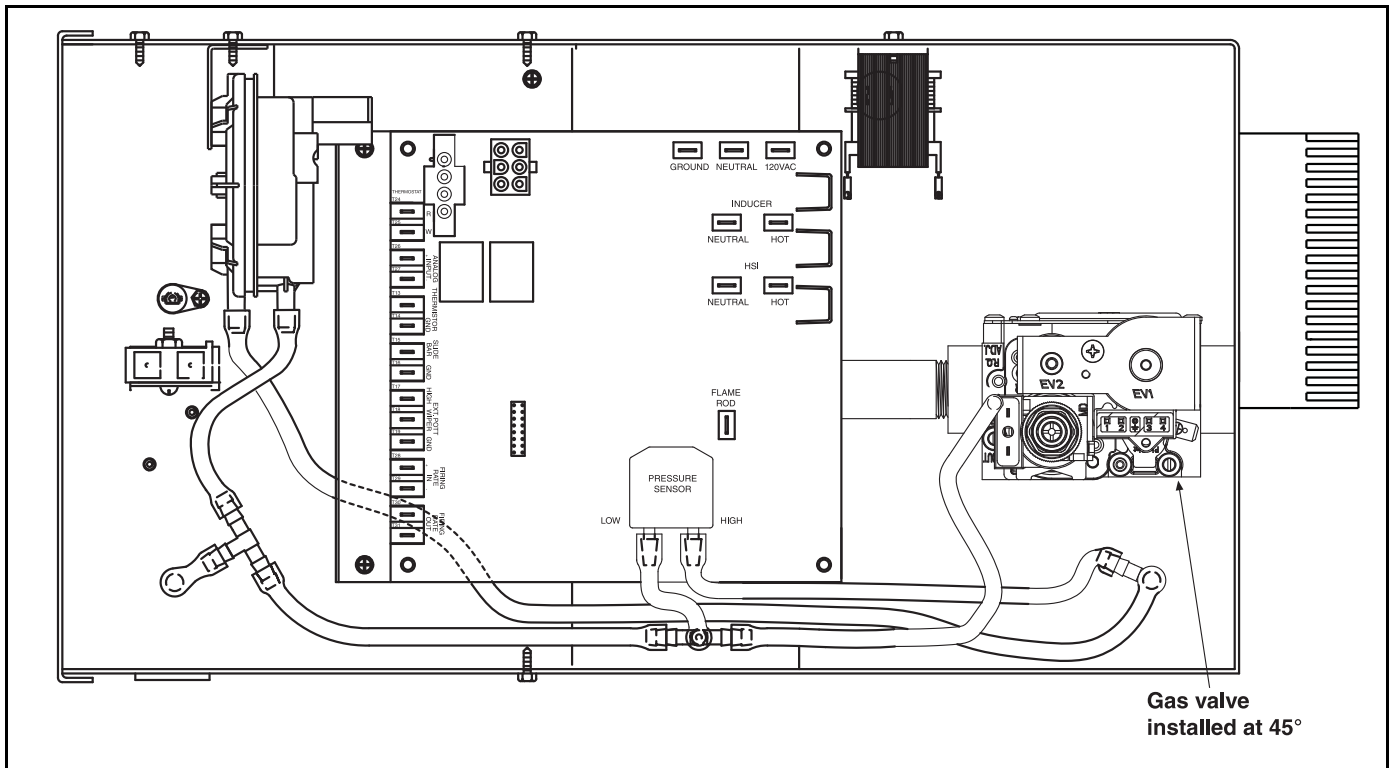
**Do not tamper with sealed parts.**

**Pressure regulator is factory calibrated for safe operation.**





**Failure to follow these instructions can result in death or injury.**



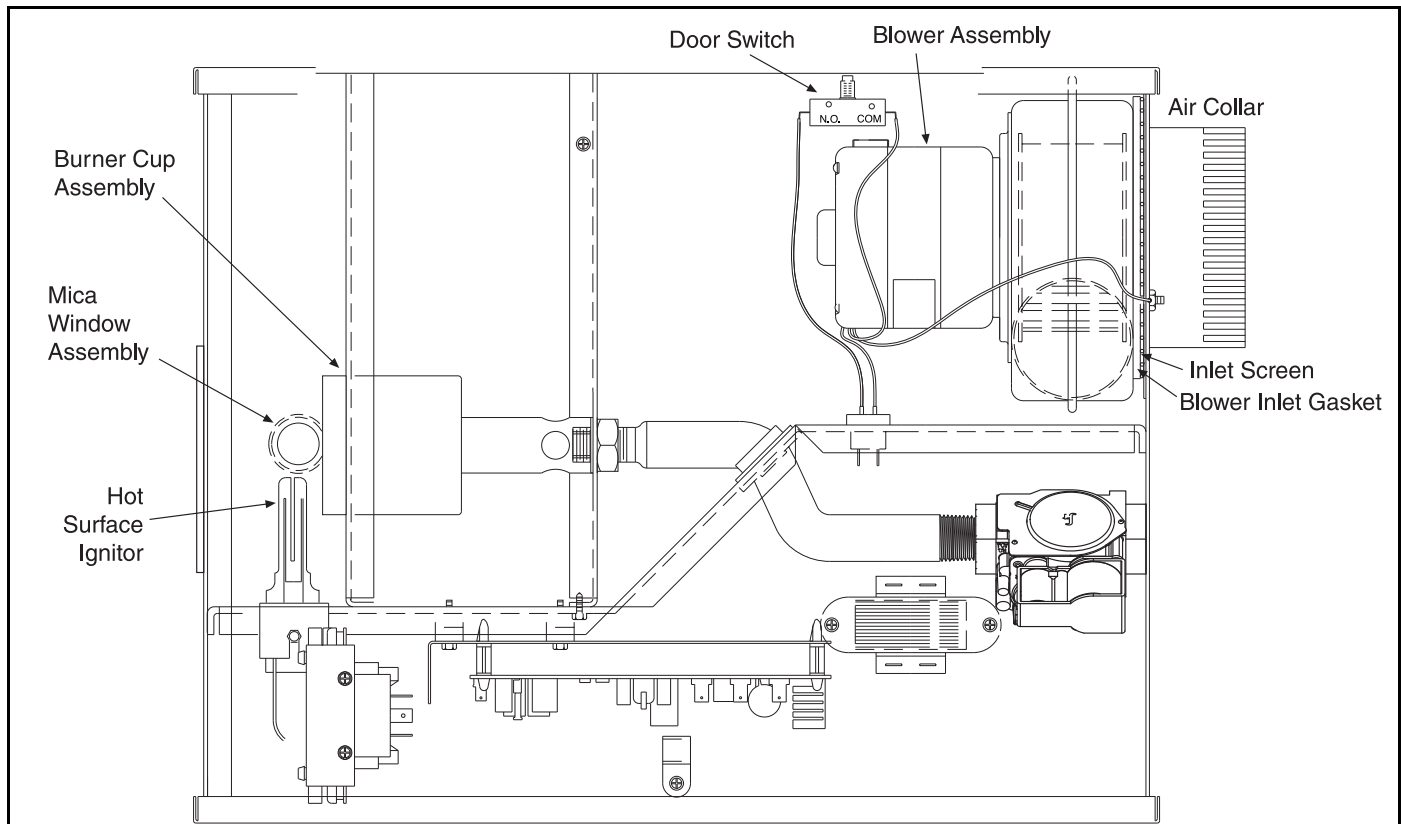
## 12.5 Pneumatic Connections



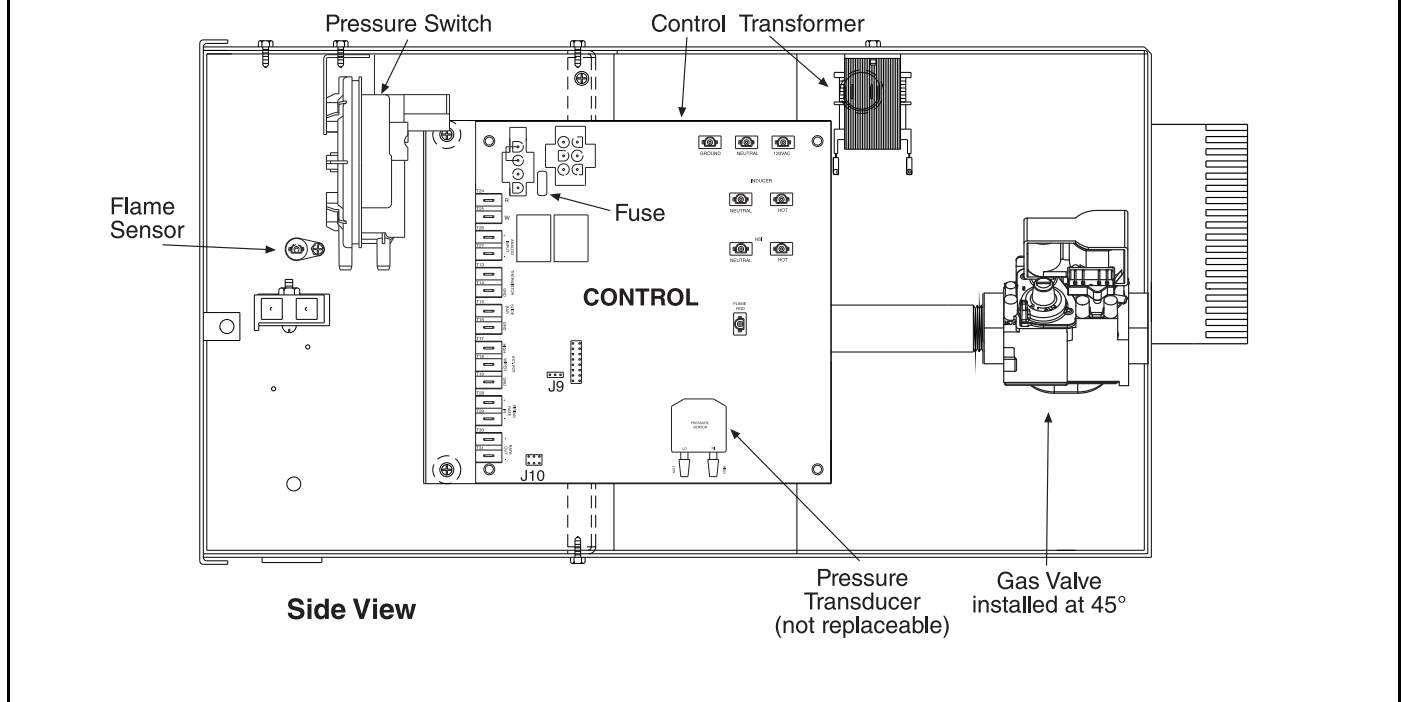
## SECTION 13: REPLACEMENT PARTS

<b>⚠ DANGER</b>	<b>⚠ WARNING</b>		
			
<b>Electrical Shock Hazard</b>	<b>Explosion Hazard</b>	<b>Fire Hazard</b>	<b>Carbon Monoxide Hazard</b>
<b>Use only genuine ROBERTS GORDON® replacement parts per this installation, operation and service manual.</b>			
<b>Failure to follow these instructions can result in death, electric shock, injury or property damage.</b>			

See warnings and important information before removing or replacing parts. After any maintenance or repair work, always test fire the heater in accordance with the start-up instructions on *Page 62, Section 11* to help ensure all safety systems are in working order before leaving the heater to operate. Minor faults may be traced by using the troubleshooting charts on *Page 65, Section 12 through Page 67, Section 12.3*.



Top View



Side View

Description	Part Number
Gas Valve (Natural)	90033105K
Gas Valve (LP)	90033104K
Tube Gasket	02568200
Blower Inlet Gasket (80, 115 models)	03050900
Blower Inlet Gasket (150, 200 models)	90709910
Blower Assembly (80, 115)	90708602-P
Blower Assembly (150, 200)	90709900-P
Air Collar (80, 115 models)	91911704
Air Collar (150, 200 models)	91911701
Combustion Air Weather Vent	03700009
Inlet Screen (80, 115)	03050800
Inlet Screen (150, 200)	09050001
Door Switch	90436800
Burner Cup Assembly	03020100
Hot Surface Igniter	90436600K
Mica Window Assembly	02553203
Flame Sensor	90439300
Transformer	90436900K
Fuse (Control) 3 A	91321403
Pressure Switch	
(80 NG, 80 LP, 115 NG, 115 LP)	90439812K
(150 NG, 150 LP, 200 NG)	90439803K
Control	
80NG	90320109K
80LP	90320110K
115NG	90320111K
115LP	90320112K
150NG	90320113K
150LP	90320114K
200NG	90320115K

**SECTION 14: GENERAL SPECIFICATIONS**

**14.1 Material Specifications**

**14.1.1 Reflectors**

.024 Aluminum  
(Optional .024 Stainless Steel Type 304)

**14.2 Heater Specifications**

**14.2.1 Control System**

Modulating Gas Valve and Hot Surface Electronic Ignition Control with Four-try, 100% shut-off, Prepurge, Post-Purge, Auto Reset, Tri-color LED Status/Fault Indicator.

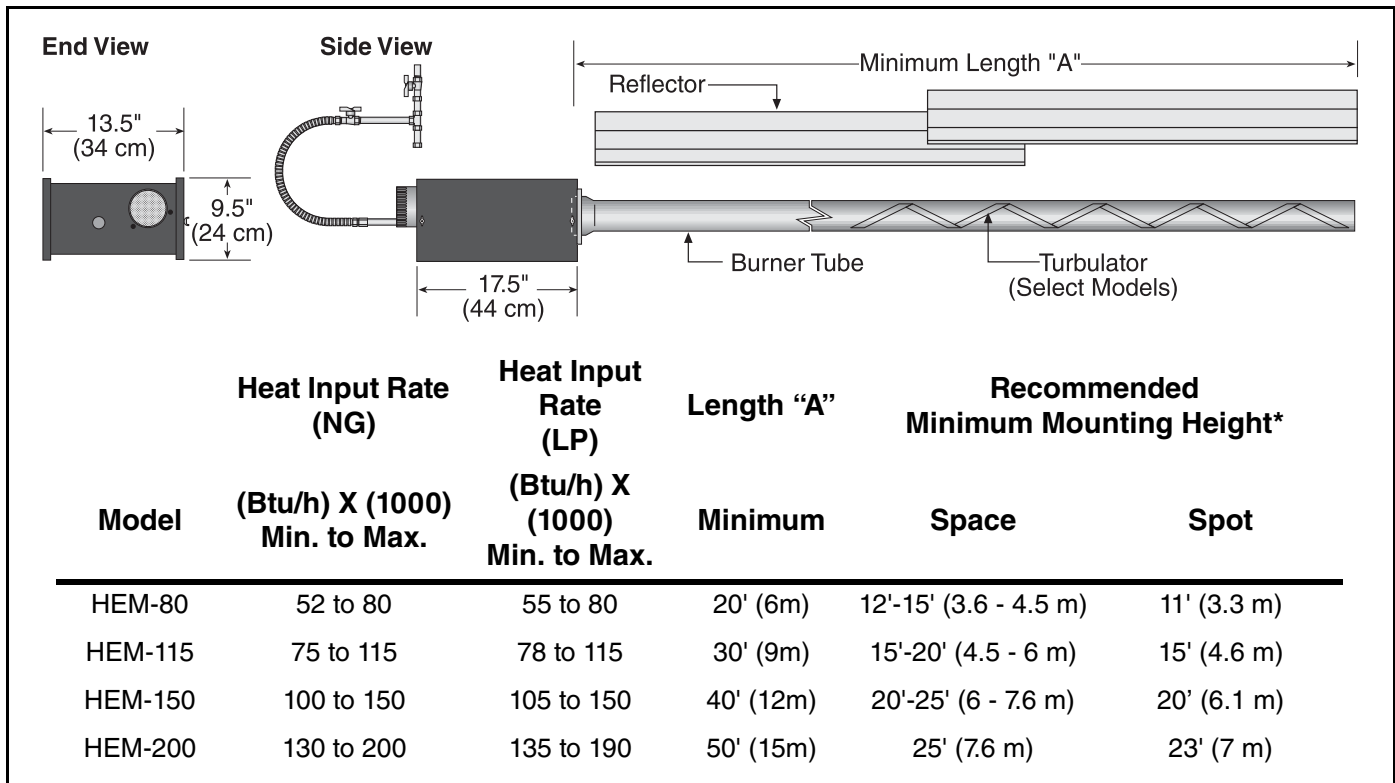
**14.3 Suspension Specifications**

Hang heater with materials with a minimum working load of 75 lbs (33 kg). See Page 16, Figure 15.

**14.4 Controls Specifications**

Time switches, sensors, etc. can be wired into the electrical supply. External controls supplied as an optional extra.

General Specifications for the heaters are as follows:



\*See Page 5, Section 3 for clearances to combustibles.

**GAS PRESSURE AT MANIFOLD:**

Natural Gas: 4.5" wc  
LP Gas: 11.0" wc

**PIPE CONNECTION:**

1/2" NPT (for 80 & 115 models)  
3/4" NPT (for 150 & 200 models)

**DIMENSIONS:**

Vent Connection Size: 4" (10 cm)  
Outside Air Connection Size:  
5" (13 cm) for 150 & 200 models  
4" (10 cm) for 80 & 115 models

Refer to figure above for dimensional information.

**GAS INLET PRESSURE:**

**Natural Gas:**

for 80, 115 & 150 models 5.5" wc Minimum  
14.0" wc Maximum  
for 200 (NG Only) 6.0" wc Minimum

**LP Gas:**

14.0" wc Maximum  
12.0" wc Minimum  
14.0" wc Maximum

**ELECTRICAL RATING (ALL MODELS):**

120V - 60 Hz., 4.8 A (start), 1.3 A (run)

## SECTION 15: THE ROBERTS GORDON® VANTAGE® HEM WARRANTY

### ROBERTS-GORDON WILL PAY FOR:

Within 36 months from date of purchase by buyer or 42 months from date of shipment by Roberts-Gordon LLC (whichever occurs first), replacement parts will be provided free of charge for any part of the product which fails due to a manufacturing or material defect.

Roberts-Gordon LLC will require the part in question to be returned to the factory. Roberts-Gordon LLC will, at its sole discretion, repair or replace after determining the nature of the defect and disposition of part in question.

ROBERTS GORDON® Replacement Parts are warranted for a period of 12 months from date of shipment from Roberts-Gordon LLC or the remaining ROBERTS GORDON® VANTAGE® HEM warranty.

### ROBERTS-GORDON WILL NOT PAY FOR:

Service trips, service calls and labor charges.

Shipment of replacement parts.

Claims where the total price of the goods have not been paid.

Damage due to:

- Improper installation, operation or maintenance.
- Misuse, abuse, neglect, or modification of the ROBERTS GORDON® VANTAGE® HEM in any way.
- Use of the ROBERTS GORDON® VANTAGE® HEM for other than its intended purpose.
- Incorrect gas or electrical supply, accident, fire, floods, acts of God, war, terrorism, or other casualty.
- Improper service, use of replacement parts or accessories not specified by Roberts-Gordon.
- Failure to install or maintain the ROBERTS GORDON® VANTAGE® HEM as directed in the Installation, Operation and Service manual.
- Relocation of the ROBERTS GORDON® VANTAGE® HEM after initial installation
- The use of the ROBERTS GORDON® VANTAGE® HEM in a corrosive atmosphere containing contaminants.
- The use of the ROBERTS GORDON® VANTAGE® HEM in the vicinity of a combustible or explosive material.
- Any defect in the ROBERTS GORDON® VANTAGE® HEM arising from a drawing, design, or specification supplied by or on behalf of the consumer.
- Damage incurred during shipment. Claim must be filed with carrier.

### WARRANTY IS VOID IF:

The ROBERTS GORDON® VANTAGE® HEM is not installed by an electrician qualified in the installation and service of gas fired heating equipment.

You cannot prove original purchase date and required annual maintenance history.

The data plate and/or serial number are removed, defaced, modified or altered in any way.

The ownership of the ROBERTS GORDON® VANTAGE® HEM is moved or transferred. This warranty is nontransferable.

Roberts-Gordon LLC is not permitted to inspect the damaged controller and/or component parts.

### READ YOUR INSTALLATION, OPERATION AND SERVICE MANUAL

If you have questions about your controller, contact your installing professional. Should you need Replacement Parts or have additional questions, call or write:

#### Roberts-Gordon LLC

1250 William Street

P.O. Box 44

Buffalo, New York 14240-0044

Telephone: +1.716.852.4400

Fax: +1.716.852.0854

Toll Free: 800.828.7450

[www.robertsgordon.com](http://www.robertsgordon.com)

**Roberts-Gordon LLC's liability, and your exclusive remedy, under this warranty or any implied warranty (including the implied warranties of merchantability and fitness for a particular purpose) is limited to providing replacement parts during the term of this warranty.** Some jurisdictions do not allow limitations on how long an implied warranty lasts ROBERTS GORDON® VANTAGE® HEM, so this limitation may not apply to you. There are no rights, warranties or conditions, expressed or implied, statutory or otherwise, other than those contained in this warranty.

**Roberts-Gordon LLC shall in no event be responsible for incidental or consequential damages or incur liability for damages in excess of the amount paid by you for the ROBERTS GORDON® VANTAGE® HEM.** Some jurisdictions do not allow the exclusion or limitation of incidental or consequential damages, so this limitation or exclusion may not apply to you. This warranty gives you specific legal rights, and you may also have other rights which vary from jurisdiction to jurisdiction.

Roberts-Gordon LLC shall not be responsible for failure to perform under the terms of this warranty if caused by circumstances out of its control, including but not limited to war, fire, flood, strike, government or court orders, acts of God, terrorism, unavailability of supplies, parts or power. No person is authorized to assume for Roberts-Gordon LLC any other warranty, obligation or liability.

### LIMITATIONS ON AUTHORITY OF REPRESENTATIVES:

No representative of Roberts-Gordon LLC, other than an Executive Officer, has authority to change or extend these provisions. Changes or extensions shall be binding only if confirmed in writing by Roberts-Gordon LLC's duly authorized Executive Officer.





**ROBERTS GORDON®**  
INFRARED HEATING

## OWNER WARRANTY REGISTRATION CARD

**Mail or Fax to:**  
Roberts Gordon LLC • 1250 William Street, P.O. Box 44 • Buffalo, NY 14240-0044 • Phone: 716-852-4400 • Fax: 716-852-0854  
Toll Free: 800-828-7450 • www.robertsgordon.com

**About the Owner:**

Name: \_\_\_\_\_  
Address: \_\_\_\_\_ City: \_\_\_\_\_ State: \_\_\_\_\_ Zip Code: \_\_\_\_\_  
Phone: \_\_\_\_\_ Fax: \_\_\_\_\_ E-mail: \_\_\_\_\_

**About the Installer:**

Name: \_\_\_\_\_  
Address: \_\_\_\_\_ City: \_\_\_\_\_ State: \_\_\_\_\_ Zip Code: \_\_\_\_\_  
Phone: \_\_\_\_\_ Fax: \_\_\_\_\_ E-mail: \_\_\_\_\_

**Purchased From (if different than installer):**

Name: \_\_\_\_\_  
Address: \_\_\_\_\_ City: \_\_\_\_\_ State: \_\_\_\_\_ Zip Code: \_\_\_\_\_  
Phone: \_\_\_\_\_ Fax: \_\_\_\_\_ E-mail: \_\_\_\_\_

**About your Heater:**

Model#: \_\_\_\_\_ Serial #: \_\_\_\_\_ Fuel: \_\_\_\_\_ Installation Date: \_\_\_\_\_

**Type of Installation (check one):**

Automotive       Manufacturing       Warehouse       Recreational       Aircraft  
 Public Building       Office       Retail       Agricultural       Other \_\_\_\_\_

**Installation Code and Annual Inspections:** All installation and service of ROBERTS GORDON® equipment must be performed by a contractor qualified in the installation and service of equipment sold and supplied by Roberts-Gordon LLC and conform to all requirements set forth in the ROBERTS GORDON® manuals and all applicable governmental authorities pertaining to the installation, service, operation and labeling of the equipment.

To help facilitate optimum performance and safety, Roberts-Gordon LLC recommends that a qualified contractor conduct, at a minimum, annual inspections of your ROBERTS GORDON® equipment and perform service where necessary, using only replacement parts sold and supplied by Roberts-Gordon LLC.

**These products are not for residential use.**

**This product is intended to assist licensed professionals in the exercise of their professional judgment.**

©2017 Roberts-Gordon LLC - All rights reserved. No part of this work covered by the copyrights herein may be reproduced or copied in any form or by any means – graphic, electronic, or mechanical, including photocopying, recording, taping, or information storage and retrieval systems – without written permission of Roberts Gordon LLC.  
Printed in the U.S.A.





Attach this information to a wall near the ROBERTS GORDON® heater.

# ROBERTS GORDON®

## Infrared Heating

Read the Installation, Operation, and Service Manual thoroughly before installation, operation, or service.

Know your model number and installed configuration.

Model number and installed configuration are found on the burner and in the Installation, Operation and Service Manual.

Write the largest clearance dimensions with permanent ink according to your model number and configuration in the open spaces below.

### OPERATING INSTRUCTIONS

1. STOP! Read all safety instructions on this information sheet.
2. Open the manual gas valve in the heater supply line.
3. Turn on electric power to the heater.
4. Set the thermostat to desired setting.

### TO TURN OFF THE HEATER

1. Set the thermostat to off or the lowest setting.

### IF THE HEATER WILL NOT OPERATE, TO ENSURE YOUR SAFETY, FOLLOW THESE INSTRUCTIONS TO SHUT DOWN YOUR HEATER

1. Set the thermostat to off or the lowest setting.
2. Turn off electric power to the heater.
3. Turn off the manual gas valve in the heater supply line.
4. Call your registered installer/contractor qualified in the installation and service of gas-fired heating equipment.

### ⚠ WARNING



#### Fire Hazard

Keep all flammable objects, liquids and vapors the minimum required clearances to combustibles away from heater.

Some objects will catch fire or explode when placed close to heater.

Failure to follow these instructions can result in death, injury or property damage.

**Maintain \_\_\_\_\_ clearance  
to the side and  
\_\_\_\_\_ clearance below  
the heater from vehicles  
and combustible materials.**

**Roberts-Gordon LLC**  
1250 William Street  
P.O. Box 44  
Buffalo, NY 14240-0044 USA  
Telephone: +1.716.852.4400  
Fax: +1.716.852.0854  
Toll Free: 800.828.7450

#### Installation Code and Annual Inspections:

All installation and service of ROBERTS GORDON® equipment must be performed by a contractor qualified in the installation and service of equipment sold and supplied by Roberts-Gordon and conform to all requirements set forth in the ROBERTS GORDON® manuals and all applicable governmental authorities pertaining to the installation, service, operation and labeling of the equipment. To help facilitate optimum performance and safety, Roberts-Gordon recommends that a qualified contractor conduct, at a minimum, annual inspections of your ROBERTS GORDON® equipment and perform service where necessary, using only replacement parts sold and supplied by Roberts-Gordon.

**Further information:** Applications, engineering and detailed guidance on systems design, installation and equipment performance is available through ROBERTS GORDON® representatives. Please contact us for any further information you may require, including the Installation, Operation and Service Manual.

**This product is not for residential use.**

© 2017 Roberts-Gordon LLC

All rights reserved. No part of this work covered by the copyrights herein may be reproduced or copied in any form or by any means – graphic, electronic, or mechanical, including photocopying, recording, taping, or information storage and retrieval systems – without written permission of Roberts-Gordon LLC.

www.robertsgordon.com

P/N 91037912 Rev. K